

D/G-35 Series

Up to 37gpm (140 l/min)

D/G-35 Specialized Designs

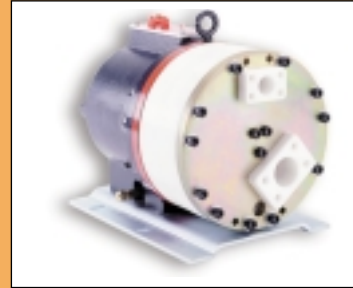

Hydra-Cell Slurry Duty pumps are specifically designed for abrasive slurry applications. See page 80 for complete specifications.



The D-35 Hydra-Cell can be equipped with an SAE or ANSI flange pump head for critical performance applications.



Hydra-Cell[®]
SIMPLY BUILT TO LAST

D/G-35 Series Performance

flow

model	max flow		max
	gpm	l/min	input rpm
D/G-35-X	36.5	138	1050
D/G-35-E	34.5	131	1150

pressure

Maximum Inlet Pressure:
250 psi (17 bar)

Pressure Variable To:
1200 psi (83 bar)

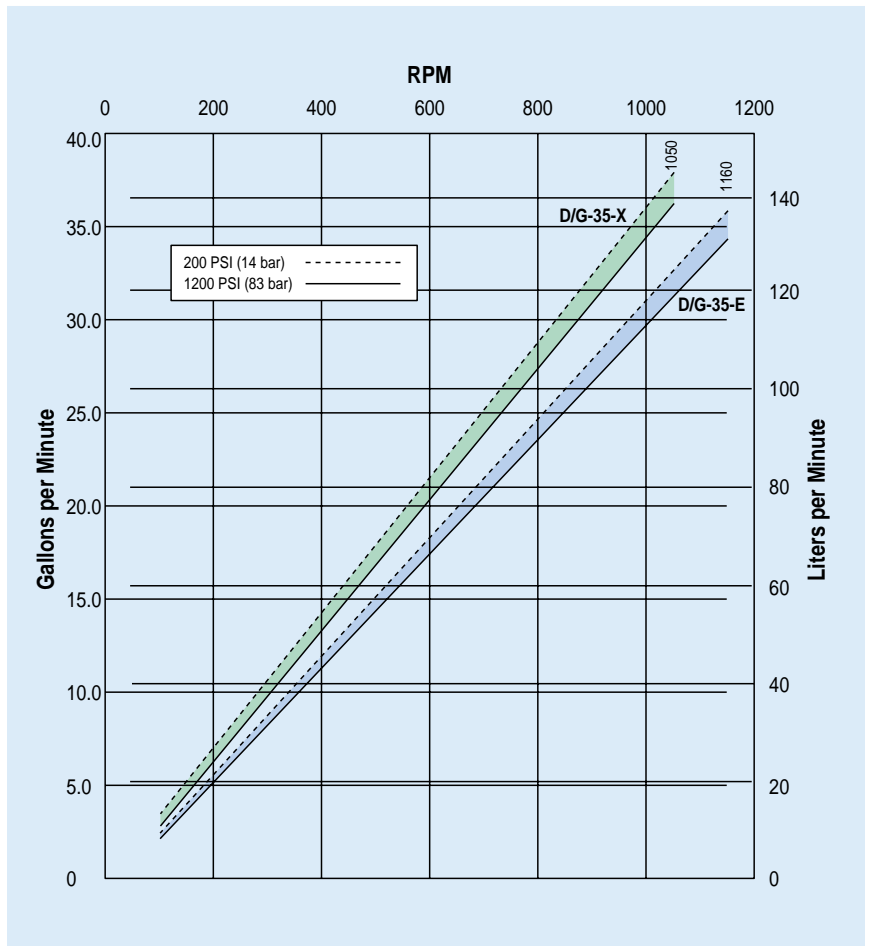

Calculating Required Horsepower (kW)**

$$\frac{100 \times \text{rpm}}{63,000} + \frac{\text{gpm} \times \text{psi}}{1,460} = \text{electric motor HP}$$

$$\frac{100 \times \text{rpm}}{84,428} + \frac{\text{lpm} \times \text{bar}}{511} = \text{electric motor kW}$$

**rpm equals pump shaft rpm. HP/kW is required application power. Use caution when sizing motors with variable speed drives.

D/G-35 Series Specifications

Max Pressure	1200 psi (83 bar)		
Capacity @ Max Pressure			
	rpm	gpm	l/min
D/G-35-X	1050	36.5	138
D/G-35-E	1150	34.5	131
Delivery @ Max Pressure			
	revs/gal	revs/liter	
D/G-35-X	29	7.7	
D/G-35-E	33	8.8	
Max Inlet Pressure	250 psi (17 bar)		
Max Temperature	250°F (121°C) – Consult factory for correct component selection for temperatures above 160°F (71°C)		
Inlet Port	D-35: 2-1/2 inch NPT or 3 inch SAE flange G-35: 2-1/2 inch BSPT		
Discharge Port	D-35: 1-1/4 inch NPT or 1-1/4 inch SAE flange G-35: 1-1/4 inch BSPT		
Shaft Diameter	2 inch		
Shaft Rotation	Bi-directional		
Bearings	Tapered roller		
Oil Capacity	5 US quarts (4.7 liters), see Accessories Section for oil selection and specification.		
Weight	240 lbs (109 kg)		

Net Positive Suction Head (NPSHr)

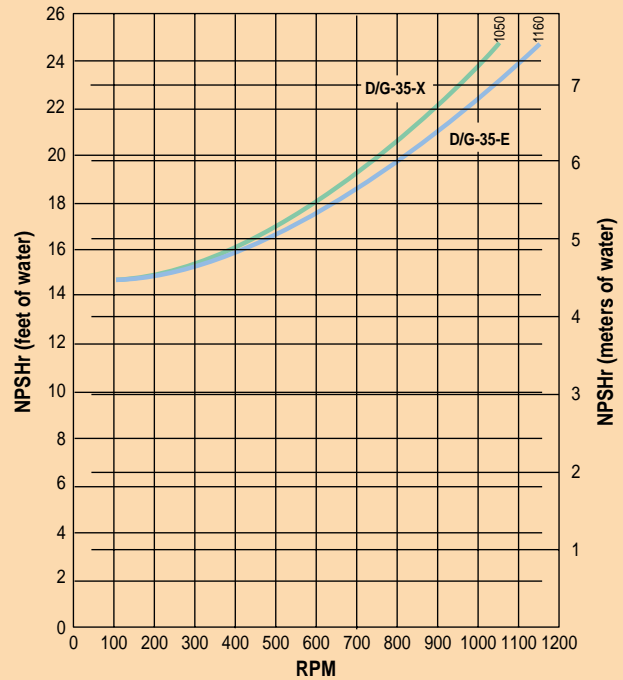

Dry Lift

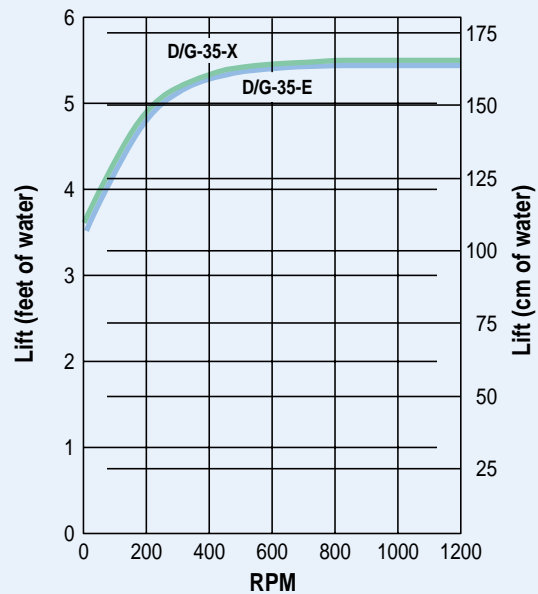

Refer to installation guidelines and design considerations section for additional information.

D/G-35 Series Dimensions

D/G-35 Models with NPT/BSPT Inlet/Outlet Ports

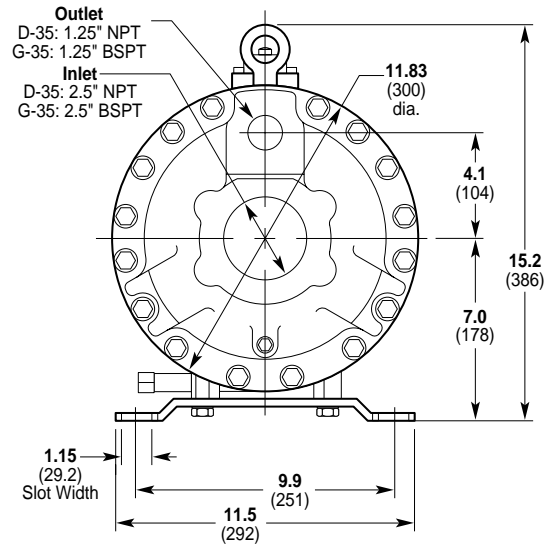
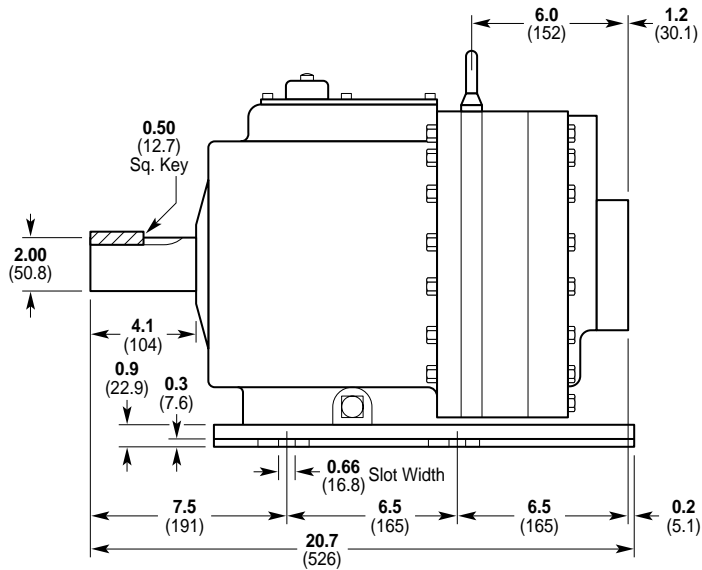

D-35 Models with SAE Flange Inlet/Outlet Ports

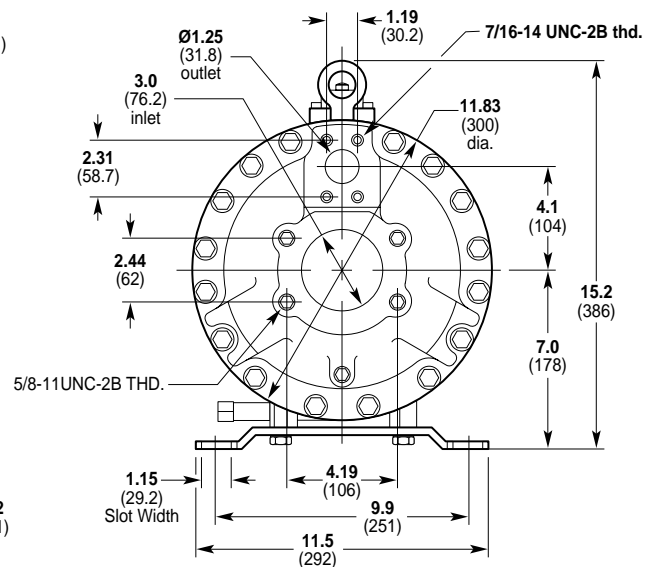
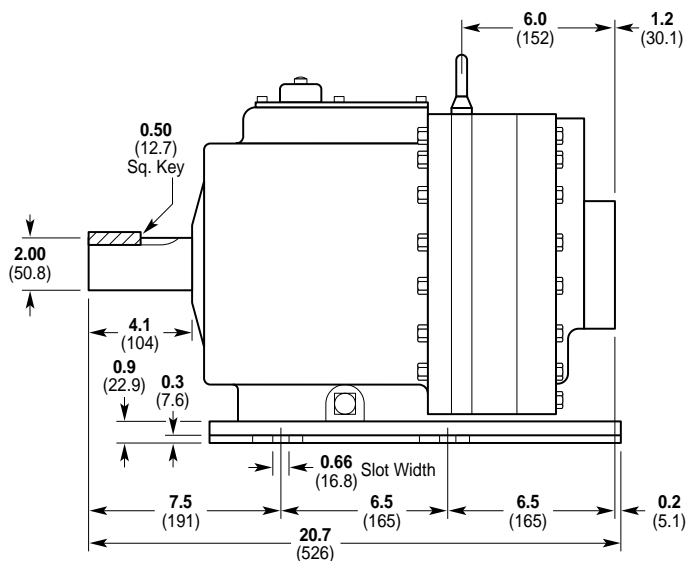

D/G-35 Series Options

Materials of Construction

Hydra-Cell pumps are manufactured in a variety of heavy-duty materials to meet specific pumping needs. Refer to the design section for more information on appropriate material selection and chemical compatibility. Other customized materials are available by special order. Contact factory application engineering department for further information.



Pumping Head
316 Stainless Steel
Brass
Ductile Iron, Nickel Plated
Nickel Alloy (Hastelloy
CW12MW)



Valves
17-4 PH Stainless Steel
Ceramic
Hastelloy® C
Nitronic 50
Tungsten Carbide



Diaphragms & O-rings
Buna-N-XS
EPDM
Neoprene
Teflon®
Viton®-XT



Valve Springs
17-7 PH Stainless Steel
Elgiloy®
Hastelloy® C



Valve Seats
17-4 PH Stainless Steel
Ceramic
Hastelloy® C
Nitronic 50
Tungsten Carbide



Valve Spring Retainers
17-7 PH Stainless Steel
Celcon®
Hastelloy® C
Kynar®
Nylon (Zytel®)
Polypropylene

D/G-35 Series Accessories

Options, Accessories and Custom Designs

See the Accessories Section for complete information on these other products:

- Valves
- Baseplates
- Guards
- Couplings
- Hose Connectors
- Hydra-Oil
- Oil Cooler and Filtering System
- Oil Reservoir
- Tool Kits



ANSI Flange Pump Heads

The D-35 Hydra-Cell can be equipped with ANSI flange pump heads for critical performance applications such as oil/gas installations and chemical process facilities.

Design Features

- 316 stainless steel flanges
- Optional ductile iron pump housing
- 2-1/2" x 150# ANSI pipe flange inlet;
1-1/4" x 600# ANSI pipe flange outlet

Ordering Information

Contact factory for complete specifications and ordering information.

D/G-35 Series How To Order

Ordering Information

A complete model number contains 12 digits of customer-specified design options: for example D35XKBTHFECA.



Digit	Order Code	Description
1-3		Pump Configuration
	D35	Shaft-driven (NPT ports or SAE Flange)
	G35	Shaft-driven (BSPT ports)
4		Hydraulic End Cam
	X	Max 37 gpm (140 lpm) @ 1050 rpm
	E	Max 35 gpm (132 lpm) @ 1150 rpm
5		Pump Head Version
	K	Kel-Cell Threaded Ports Version Pump Head
	E	Kel-Cell SAE Flange Version Pump Head
6		Pump Head Material
	B	Brass
	C	Cast Iron (nickel plated)
	S	316 Stainless Steel
	T	Nickel Alloy (Hastelloy® CW12MW)
7		Diaphragm & O-ring Material
	E	EPDM (requires EPDM-compatible oil – Digit 12 oil code C or D)
	G	Viton®-XT
	J*	Teflon® (available with E cam only; 1050 rpm max)
	P	Neoprene
	T	Buna-N-XS
8		Valve Seat Material
	C	Ceramic
	D	Tungsten Carbide
	H	17-4 PH Stainless Steel
	N	Nitronic 50
	T	Hastelloy® C
9		Valve Material
	C	Ceramic
	D	Tungsten Carbide
	F	17-4 PH Stainless Steel – Machined
	N	Nitronic 50
	T	Hastelloy® C
10		Valve Springs
	E	Elgiloy®
	H	17-7 PH Stainless Steel
	T	Hastelloy® C

Digit	Order Code	Description
11		Valve Spring Retainers
	C	Celcon
	H	17-7 PH Stainless Steel
	M	Kynar®
	P	Polypropylene
	T	Hastelloy® C
	Y	Nylon (Zytel)
12		Hydra-Oil
	A	10W30 standard duty oil
	B	40-wt for continuous duty (use with 316 SST or Hastelloy® pump head)
	D	40-wt high-temp EPDM-compatible oil
	F	40-wt high-temp food-contact oil
	G	5W30 cold-temp severe duty oil
	H	15W50 high-temp severe duty synthetic oil

Replacement Hydraulic End Assembly

Complete D/G-35 Hydraulic End Assemblies are available as replacement items. The Hydraulic End contains all drive end components from the drive shaft up to and including the diaphragms. All Hydraulic Ends are factory tested and shipped with oil. To order a Replacement Hydraulic End, specify the desired Cam (Digit 4), the Diaphragm and O-ring Material (Digit 7), and the Hydra-Oil (Digit 12).

Part Number*

D35 4* **XX** 7* **XXXX** 12* **G35** 4* **XX** 7* **XXXX** 12*

* Order Code Digits 4, 7 and 12 must be filled in when ordering.

* May require pressurized inlet.