

D/G-03 Series

Up to 3 gpm (11.3 l/min)

M-23 Integral Gas Engine Powered System

The M-23 is designed for close coupling with a Honda engine (Model GX160K1LX2) 5.5 HP with 2:1 gearbox.

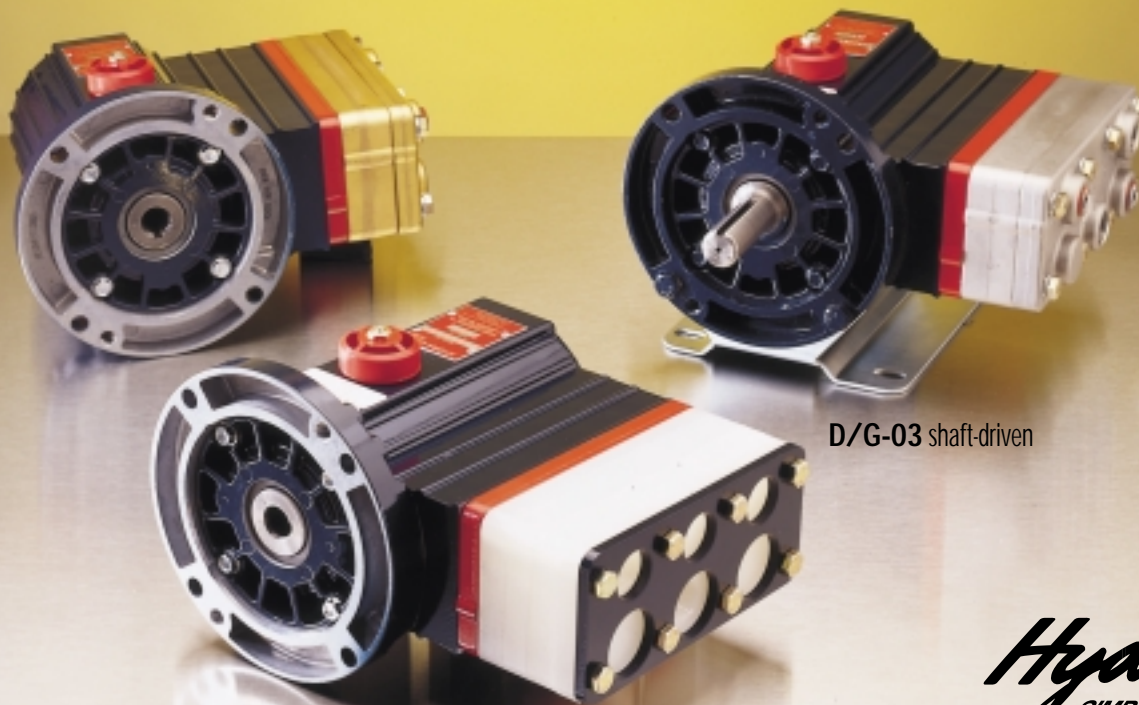

D/G-03 shaft-driven

M-03/G-13 hollow shaft design for close coupling with NEMA 56C C-Face and IEC 80 B5 Flange motors

Hydra-Cell[®]
SIMPLY BUILT TO LAST

D/G-03 Series Performance

flow

model*	max flow		max input rpm
	gpm	l/min	
D/G-03-X	3.0	11.3	1750
D/G-03-E	2.2	8.3	1750
D/G-03-S	1.8	6.8	1750
D/G-03-B	1.1	4.2	1750
D/G-03-G	0.5	1.9	1750

pressure

Maximum Inlet Pressure:
250 psi (17 bar)

Pressure Variable To:

Metallic Heads:

D/G-03-X:	1000 psi (69 bar)
D/G-03-E:	1200 psi (83 bar)
D/G-03-S:	1200 psi (83 bar)
D/G-03-B:	1200 psi (83 bar)
D/G-03-G:	1200 psi (83 bar)

Non-Metallic Heads:

All Models:	250 psi (17 bar)
-------------	------------------

* Note

Performance and specification ratings apply to all configurations unless specifically noted otherwise.

Calculating Required Horsepower (kW)**

$$\frac{6 \times \text{rpm}}{63,000} + \frac{\text{gpm} \times \text{psi}}{1,460} = \text{electric motor HP}$$

$$\frac{6 \times \text{rpm}}{84,428} + \frac{\text{lpm} \times \text{bar}}{511} = \text{electric motor kW}$$

**rpm equals pump shaft rpm. HP/kW is required application power. Use caution when sizing motors with variable speed drives.

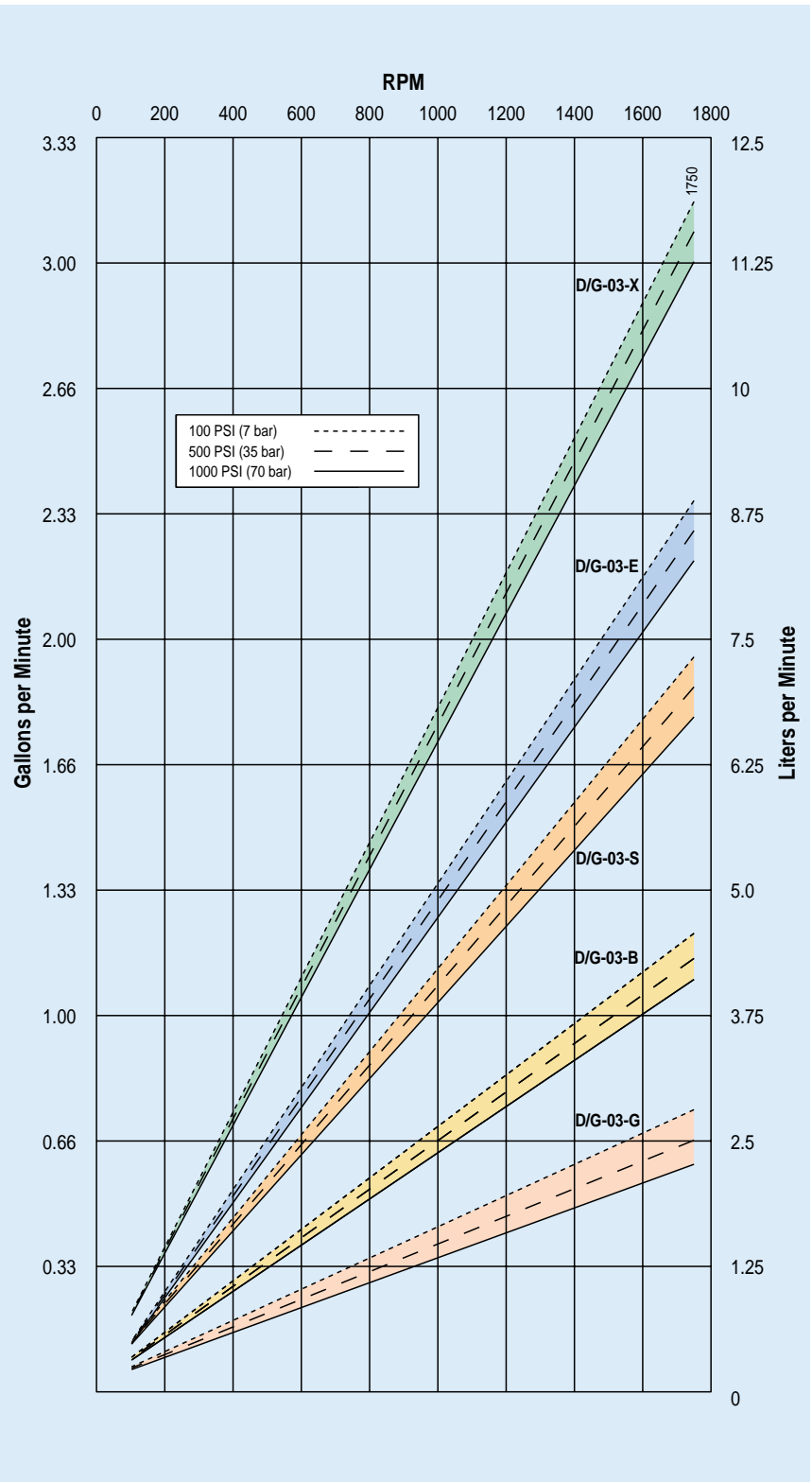

D/G-03 Series Specifications

Max Pressure*

Metallic Heads:	D/G-03-X: 1000 psi (69 bar)
	D/G-03-S, E, B, G: 1200 psi (83 bar)
Non-Metallic Heads:	All models: 250 psi (17.3 bar)

Maximum Capacity*

	rpm	gpm	l/min
D/G-03-X	1750	3.0	11.3
D/G-03-E	1750	2.2	8.3
D/G-03-S	1750	1.8	6.8
D/G-03-B	1750	1.1	4.2
D/G-03-G	1750	0.5	1.9

Delivery @ Max Pressure*

	revs/gal	revs/liter
D/G-03-X	584	155
D/G-03-E	795	204
D/G-03-S	972	258
D/G-03-B	1591	415
D/G-03-G	3500	906

Max Inlet Pressure 250 psi (17.3 bar)

Max Temperature

Metallic Heads:	250°F (121°C) – Consult factory for correct component selection for temperatures above 160°F (71°C)
	Non-Metallic Heads: 140°F (60°C)

Inlet Port D-03, M-03, M-23: 1/2 inch NPT
G-03, G-13: 1/2 inch BSPT

Discharge Port D-03, M-03, M-23: 3/8 inch NPT
G-03, G-13: 3/8 inch BSPT

Shaft Diameter D/G-03: 7/8 inch (22.22 mm) shaft-driven
M-03: 5/8 inch hollow shaft for NEMA 56C C-Face motor
G-13: 24 mm hollow shaft for IEC 90 B5 Flange motor
M-23: 20 mm hollow shaft for use with Honda engine

Shaft Rotation Bi-directional

Bearings Ball bearings

Oil Capacity 1 US quart (0.95 liters), see Accessories Section for oil selection and specification.

Weight

Metallic Heads:	28 lbs (12.7 kg)
Non-Metallic Heads:	19 lbs (8.6 kg)

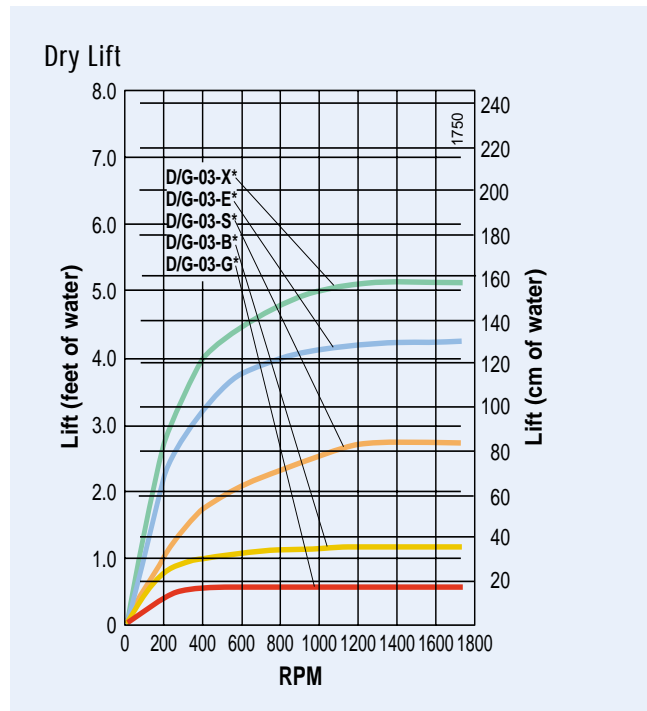
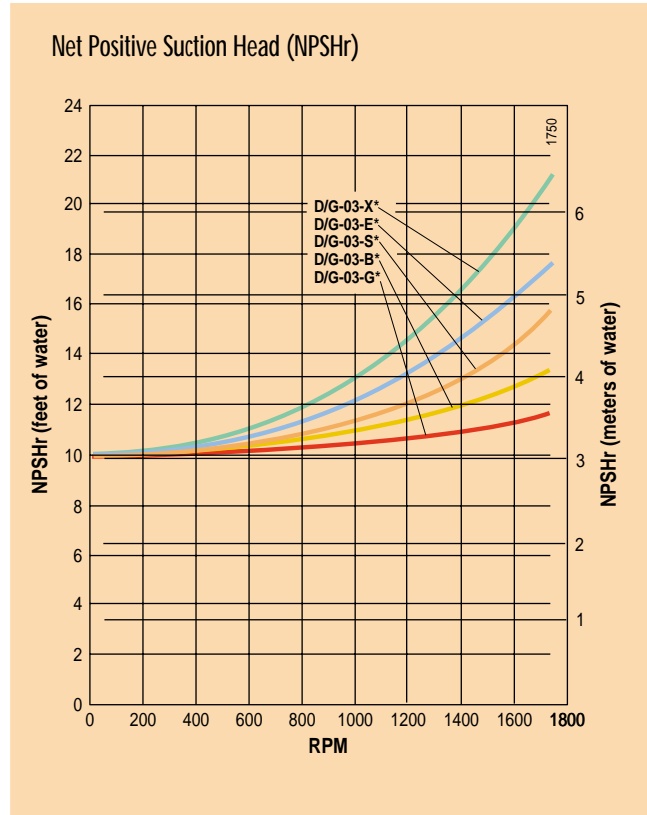

* Note

Performance and specification ratings apply to all configurations unless specifically noted otherwise.

Refer to installation guidelines and design considerations for additional information.

D/G-03 Series Dimensions

M-03/G-13 Models with Metallic Pumping Head

Brass
316 Stainless Steel
Nickel Alloy (Hastelloy CW12MW)

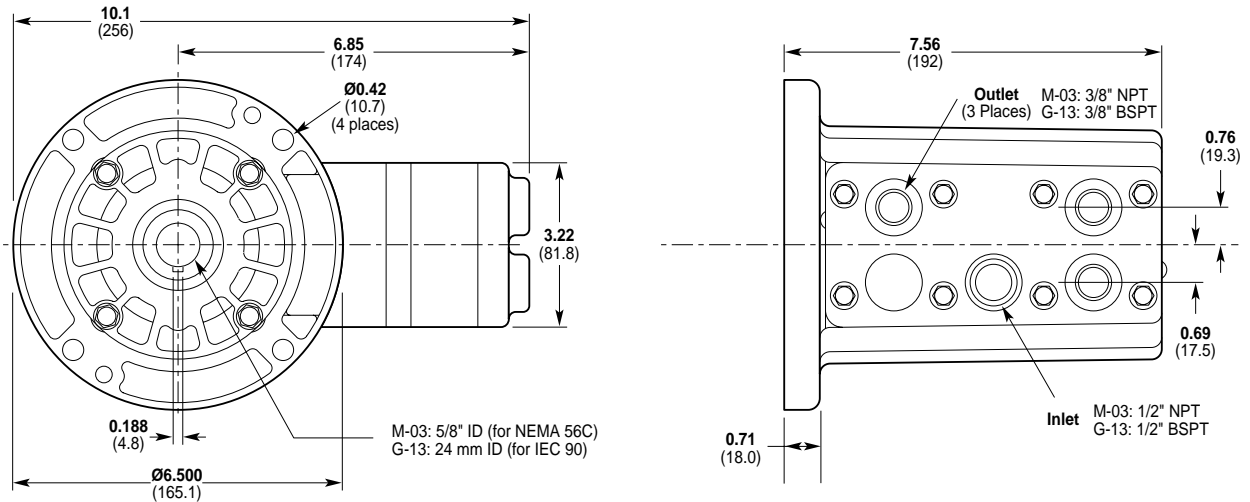

M-03/G-13 Models with Non-metallic Pump Head

Kynar®
Polypropylene

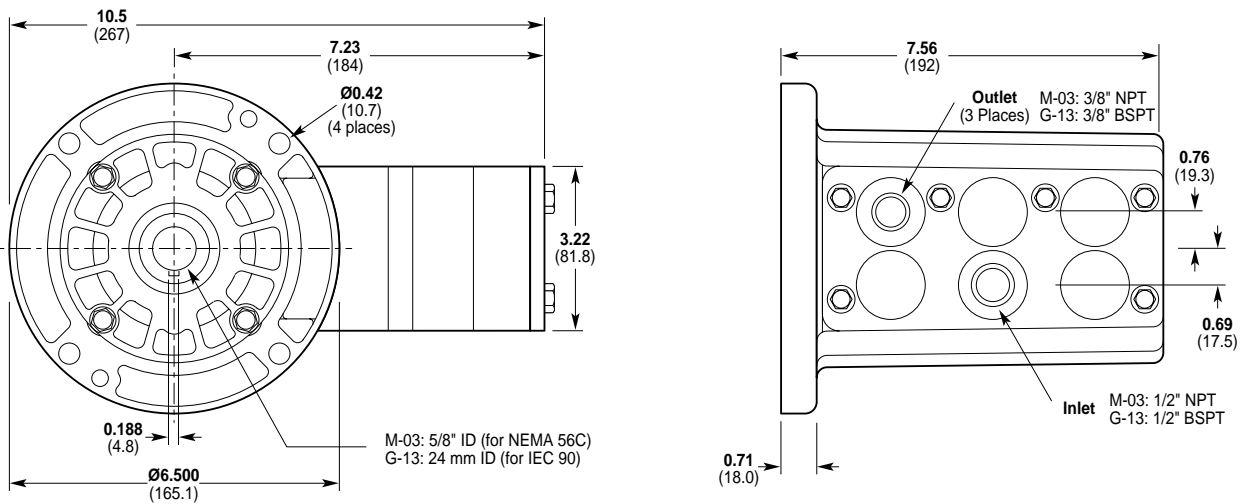

D/G-03 Series Dimensions

D/G-03 Models with Metallic Pumping Head

Brass
316 Stainless Steel
Nickel Alloy (Hastelloy CW12MW)

– Note
D/G-03 Pump/Motor Adapter
flange ordered separately
(see accessories, page 40)

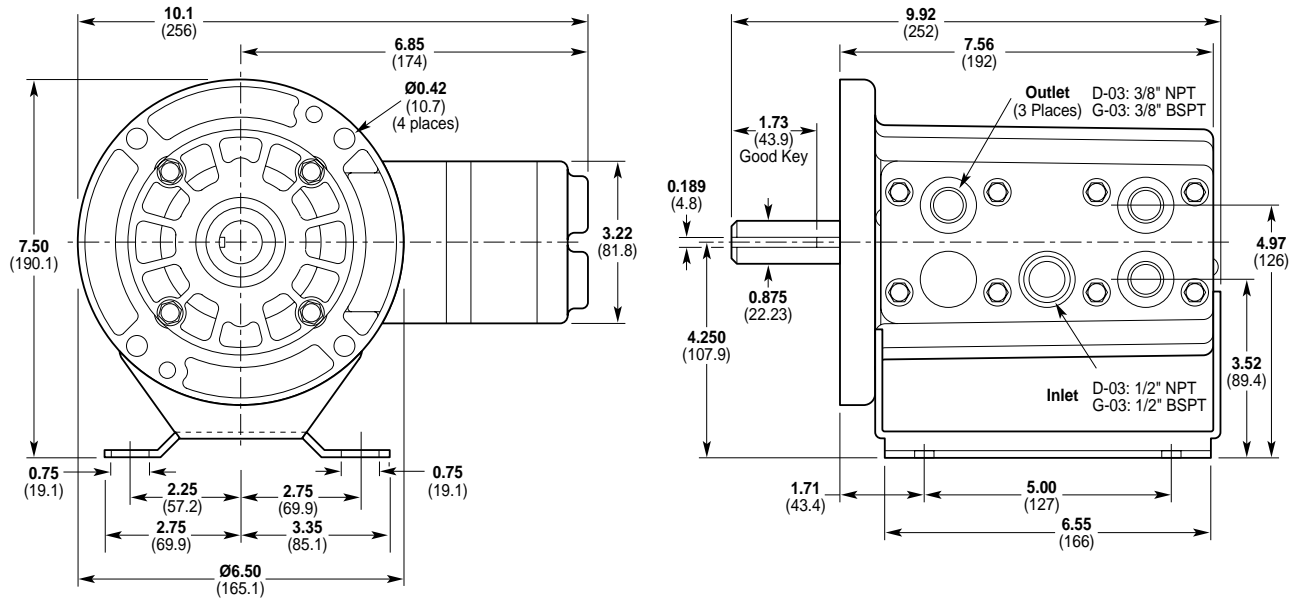

D/G-03 Models with Non-metallic Pump Head

Kynar®
Polypropylene

– Note
D/G-03 Pump/Motor Adapter
flange ordered separately
(see accessories, page 40)

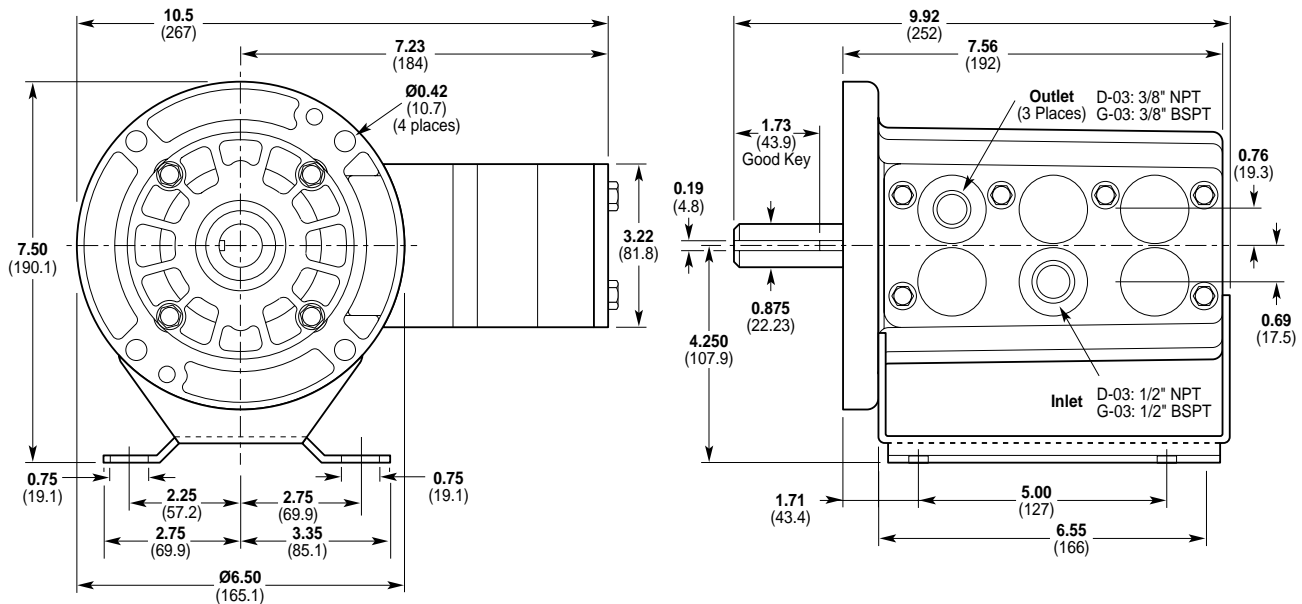

D/G-03 Series Dimensions

M-23 Models with Metallic Pumping Head

Brass
316 Stainless Steel
Nickel Alloy (Hastelloy CW12MW)

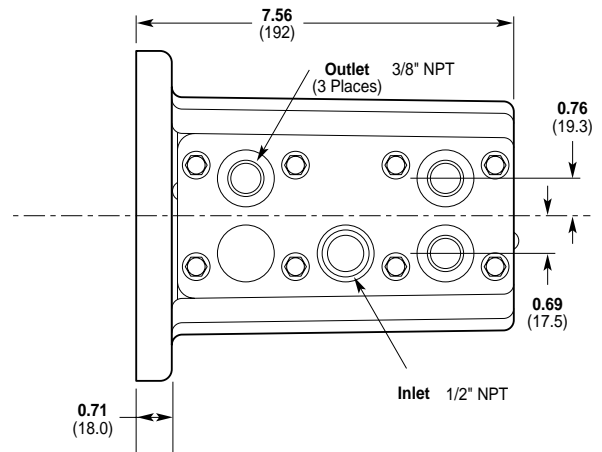
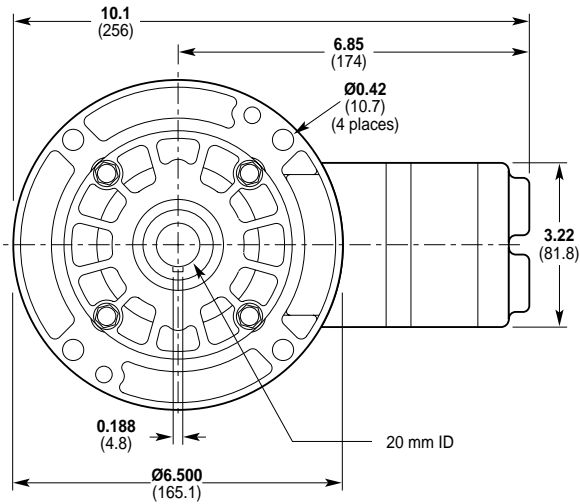

M-23 Models with Non-metallic Pump Head

Kynar®
Polypropylene

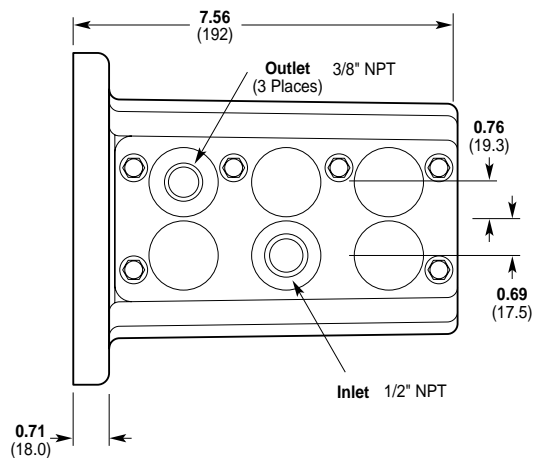
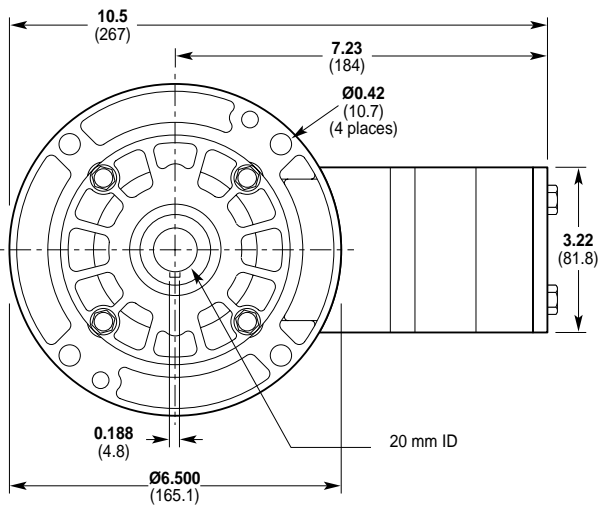

D/G-03 Series Options

Materials of Construction

Hydra-Cell pumps are manufactured in a variety of heavy-duty materials to meet specific pumping needs. Refer to the design section for more information on appropriate material selection and chemical compatibility. Other customized materials are available by special order. Contact factory application engineering department for further information.



Pumping Head
 316 Stainless Steel
 Brass
 Kynar®
 Nickel Alloy (Hastelloy®
 CW12MW)
 Polypropylene



Valves
 17-4 PH Stainless Steel
 17-7 PH Stainless Steel
 316 Stainless Steel
 Ceramic
 Hastelloy® C
 Nitronic 50
 Tungsten Carbide



Diaphragms & O-rings
 Buna-N-XS
 EPDM
 Neoprene
 Teflon®
 Viton®-XT



Valve Springs
 316 Stainless Steel
 Elgiloy®
 Hastelloy® C



Valve Seats
 17-4 PH Stainless Steel
 316 Stainless Steel
 Ceramic
 Hastelloy® C
 Tungsten Carbide



Valve Spring Retainers
 Celcon®
 Kynar®
 Nylon
 Polypropylene
 17-7 PH Stainless Steel
 Hastelloy® C

D/G-03 Series Accessories

Options, Accessories and Custom Designs

See the Accessories Section for complete information on these other products:

- Valves
- Couplings
- Hose Connectors
- Hydra-Oil
- Oil Cooler and Filtering System
- Oil Reservoir
- Tool Kits
- Pump/Motor Adapters



Pump/Motor Adapter

(Ordered Separately)

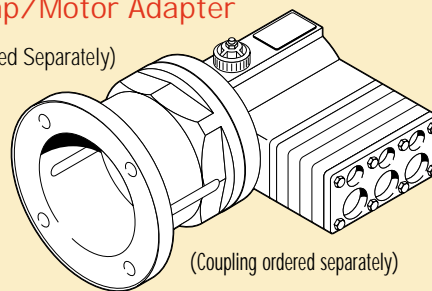

(Coupling ordered separately)

Part Number: A04-001-1202

For D-03 for use with NEMA 56C,
 143/145TC C-Face motors.

Part Number: A04-002-1202

For D-03 for use with NEMA 182/
 184TC, 213/215TC C-Face motors.

Part Number: A04-003-1202

For G-03 for use with IEC
 80-90 B5 Flange motors.

Part Number: A04-004-1202

For G-03 for use with IEC
 100-112 B5 Flange motors.

See the Accessories Section for dimensions.

D/G-03 Series How To Order

Ordering Information

A complete model number contains 12 digits of customer-specified design options: for example M03XABTHHECA.

1	2	3	4	5	6	7	8	9	10	11	12
---	---	---	---	---	---	---	---	---	----	----	----

Digit	Order Code	Description
1-3		Pump Configuration
	D03	Shaft-driven (NPT ports)
	M03	Close-coupled to NEMA 56C (NPT ports)
	M23	For use with 5.5 HP Honda Engine (Model GX160K1LX2 engine not included)
	G03	Shaft-driven (BSPT ports)
	G13	Close-coupled to IEC 90 B5 (BSPT ports)
4		Hydraulic End Cam
	X	Max 3.0 gpm (11.3 lpm) @ 1750 rpm
	E	Max 2.2 gpm (8.3 lpm) @ 1750 rpm
	S	Max 1.8 gpm (6.8 lpm) @ 1750 rpm
	B*	Max 1.1 gpm (4.2 lpm) @ 1750 rpm
	G*	Max 0.5 gpm (1.9 lpm) @ 1750 rpm
5		Pump Head Version
	A	Version A Pump Head (NPT ports)
	D	Version D Pump Head (BSPT ports)
6		Pump Head Material
	B	Brass
	M	Kynar®
	P	Polypropylene
	S	316 Stainless Steel
	T	Nickel Alloy (Hastelloy® CW12MW)
7		Diaphragm & O-ring Material
	E	EPDM (requires EPDM-compatible oil – Digit 12 oil code J)
	G	Viton®-XT
	J*	Teflon® (available with X and E cams only; cannot be used with non-metallic heads)
	P	Neoprene
	T	Buna-N-XS
8		Valve Seat Material
	C	Ceramic
	D	Tungsten Carbide
	H	17-4 PH Stainless Steel
	S	316 Stainless Steel
	T	Hastelloy® C

Digit	Order Code	Description
9		Valve Material
	C	Ceramic
	D	Tungsten Carbide
	F	17-4 PH Stainless Steel – Machined
	H	17-7 PH Stainless Steel
	N	Nitronic 50
	S	316 Stainless Steel
	T	Hastelloy® C
10		Valve Springs
	E	Elgiloy®
	S	316 Stainless Steel
	T	Hastelloy® C
11		Valve Spring Retainers
	C	Celcon
	H	17-7 PH Stainless Steel
	M	Kynar®
	P	Polypropylene
	T	Hastelloy® C
	Y	Nylon
12		Hydra-Oil
	A	10W30 standard duty oil
	G	5W30 standard & cold-temp severe duty oil
	J	20-wt EPDM-compatible oil
	K	20-wt food-contact oil

Replacement Hydraulic End Assembly

Complete D/G-03 Hydraulic End Assemblies are available as replacement items. The Hydraulic End contains all drive end components from the drive shaft up to and including the diaphragms. All Hydraulic Ends are factory tested and shipped with oil. To order a Replacement Hydraulic End, specify the desired Cam (Digit 4), the Diaphragm and O-ring Material (Digit 7), and the Hydra-Oil (Digit 12).

Part Number*

D03 4* XX 7* XXXX 12* G03 4* XX 7* XXXX 12*

M03 4* XX 7* XXXX 12* G13 4* XX 7* XXXX 12*

M23 4* XX 7* XXXX 12*

* Order Code Digits 4, 7 and 12 must be filled in when ordering.

* May require pressurized inlet.