

# PARTS MANUAL

## INSTALLATION & SERVICE

# Hydra-Cell®

## INDUSTRIAL VALVES

### IMPORTANT

Record your pump model number and serial number here for easy reference:

Model No. \_\_\_\_\_

Serial No. \_\_\_\_\_

Date of Purchase \_\_\_\_\_

When ordering parts or making inquiries about this pump, please mention the model and serial numbers.

## **METRIC MODELS: C22-D, C23-D, C24-D**

### **BYPASS PRESSURE REGULATING VALVES**

**With BSPT Threaded Ports**

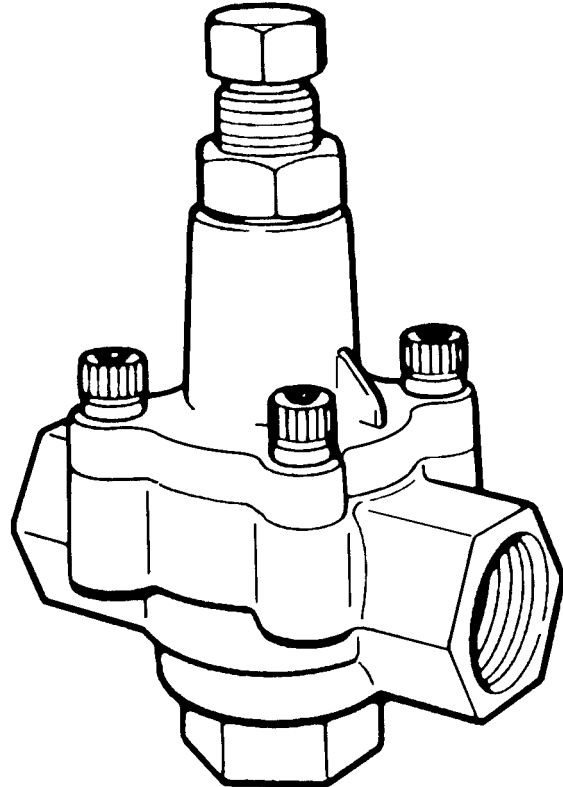

**WANNER ENGINEERING, INC.**

1204 Chestnut Avenue, Minneapolis, MN 55403  
TEL: (612) 332-5681 FAX: (612) 332-6937  
TOLL-FREE FAX [US only]: (800) 332-6812

[www.hydra-cell.com](http://www.hydra-cell.com)  
email: [sales@wannereng.com](mailto:sales@wannereng.com)

# C22/23/24-D Contents

---

	<b>Page</b>
Specifications .....	2
Installation .....	4
Disc Arrangement .....	5
C22-D Parts .....	6
C23-D Parts .....	8
C24-D Parts .....	10
Repair & Troubleshooting .....	11

# C22/23/24-D Specifications

---

## Specifications

<b>Capacity:</b>	<b>Maximum</b>	<b>Minimum</b>
	l./min	l./min
C22-D	38	11
C23-D	76	11
C24-D	152	19

<b>Pressure Range (bar):</b>	<b>Model Configuration</b>			
	<b>DA</b>	<b>DB</b>	<b>DC</b>	<b>DE</b>
C22-D	5-34	34-69	69-103	103-172
C23-D	5-34	34-69	69-103	103-172
C24-D	5-34	34-69	69-103	—

**Max Temperature:** 200°F

### Inlet and Outlet Ports:

C22-D	3/4" BSPT
C23-D	1" BSPT
C24-D	1-1/4" BSPT

### Dimensions: (H x W x D)

C22-DA, DB, DC	152.4 x 86.4 x 55.9 mm
C22-DE	163.6 x 86.4 x 55.9 mm
C23-DA, DB, DC	178 x 122 x 71.1 mm
C23-DE	88 x 122 x 71.1 mm
C24-DA, DB, DC	229 x 137.2 x 83.8 mm

### Weight

C22-D	1.3 kg
C23-D	2.7 kg
C24-D	4.5 kg

# C22/23/24-D Installation

## Location

The Bypass Pressure Regulating Valve prevents system pressure from exceeding a preset maximum. As the system approaches this maximum pressure, excess fluid is bypassed (to a supply tank, or to the pump inlet). This prevents overpressurization and system failures.

Install the regulating valve between the pump outlet (as close to the pump as possible) and any shut-off device in the discharge plumbing. It may be located **in** the discharge line, or **off**-line:

- If in-line, use either of the horizontal ports as the inlet and the other as the outlet;
- If off-line, use either of the horizontal ports as the inlet and plug the other one.

The **bottom** port is always the bypass port.

## Mounting Position

The preferred mounting position is vertical with the adjusting bolt at the top.

## Connections

For best operation, the bypass line should return to the supply tank. If you must plumb the bypass line back to the pump inlet instead, have it enter the inlet line as far from the pump as possible. Contact the pump manufacturer, as a pressure regulator may be required in the pump inlet.

The bypass line should be as large as the ports of the regulating valve. Do **not** install shutoff valves or other restrictions.

Install a high-quality industrial pressure gauge in the discharge system to monitor system pressure. Failure to do so may result in overpressurization and premature failure of pumping system components.

For smoothest operation and minimal pressure spiking when the discharge system is closed (closed gun, plugged nozzles, valve closed), about 10% of the rated flow of the regulating valve should be bypassed at all times.

**Example:** With the C22D valve (rated at 38 l/m), 3 l/m should be bypassing at all times during operation. If the desired spray gun delivery is 22 l/m, then the pump should deliver 26 l/m (22 l/m to the gun and 4 l/m to be bypassed). The nozzle orifices should be properly sized for 22 l/m delivery at the desired pressure; the pump RPM for 26 l/m; and the pump HP for 26 l/m at the bypass pressure (bypass pressure is higher than nozzle pressure).

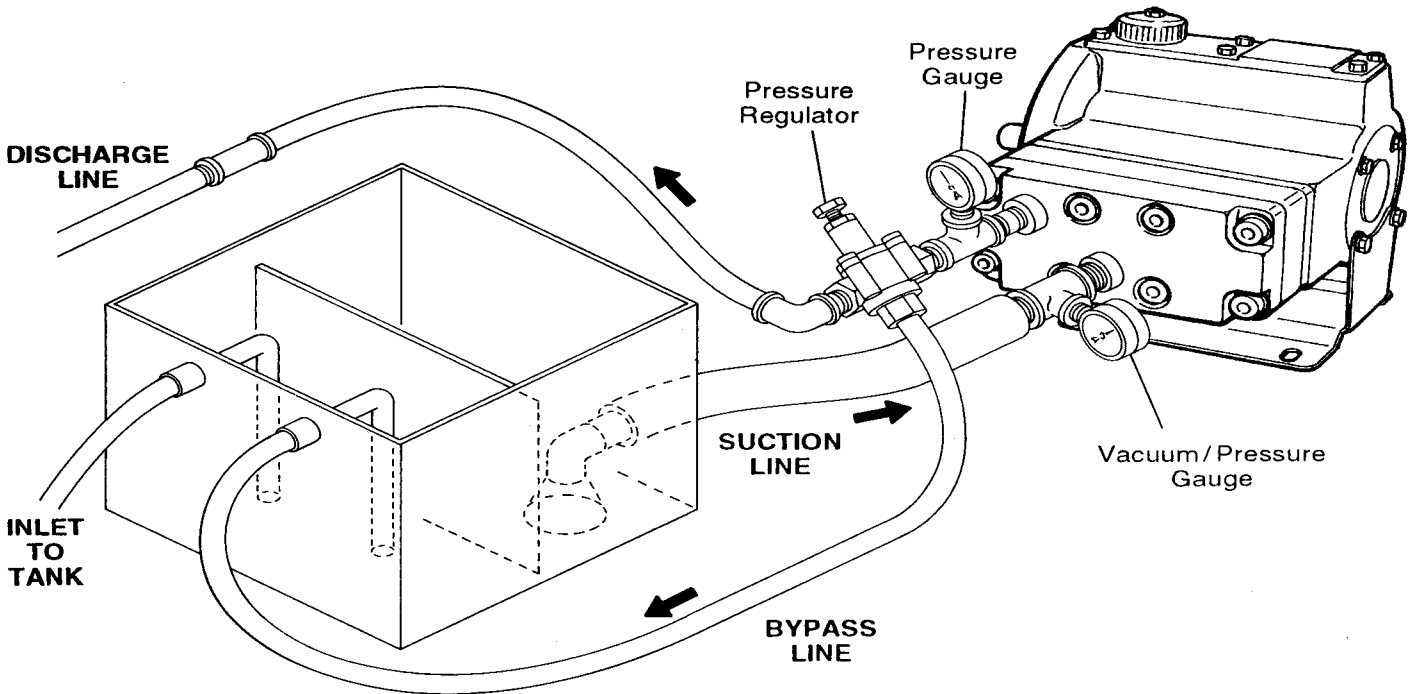

# C22/23/24-D Installation

## Pressure Adjustment

### Systems *with* Shutoff Guns or Valves

1. Turn off the system.
2. Turn the adjusting nut counterclockwise until there is no longer any pressure on the springs in the regulating valve.
3. Close the discharge line.
4. Be sure the piping and all valves and nozzles are open.  
With an accurate pressure gauge installed in the system, start the system and let it run for a few minutes to remove any air.
5. When all air has been removed, begin turning the adjusting nut clockwise until the desired bypass pressure is reached.  
**Do not exceed the maximum rated pressure of the pump or the regulating valve!**
6. Open and close the discharge line 3 or 4 times. Re-check the bypass pressure each time, and readjust if necessary. Turn the adjusting nut clockwise to increase or counterclockwise to reduce the pressure.
7. Check that the fluid bypass is continuous and adequate. With guns or valves open, you should be bypassing about 10% of the rated flow of the regulating valve (see the Example above). If the system discharge pressure is less than desired when 10% of the flow is bypassing, check the pump speed and delivery and the size of the nozzle or system orifice.
8. When both the bypass pressure and the flow have been set, turn the locknut clockwise to lock in the adjustment.

### Systems *without* Shutoff Guns or Valves

**Note:** When making this adjustment, you must be able to observe the amount of fluid being bypassed.

1. Turn off the system.
2. Turn the adjusting nut counterclockwise until there is no longer any pressure on the springs in the regulating valve.
3. With an accurate pressure gauge installed in the system start the system and let it run for a few minutes to remove any air. The full flow of the pump should be bypassing.
4. Be sure all nozzles are open.
5. When all air has been removed, begin turning the adjusting nut clockwise until the desired bypass pressure is reached, or until no fluid is being bypassed — whichever occurs first.  
Do not exceed the maximum rated pressure of the pump or the regulating valve!
6. If the system discharge pressure is less than desired, check the pump speed and delivery and the size of the nozzle or system orifice.
7. When both the bypass pressure and the flow have been set, turn the locknut clockwise to lock in the adjustment.

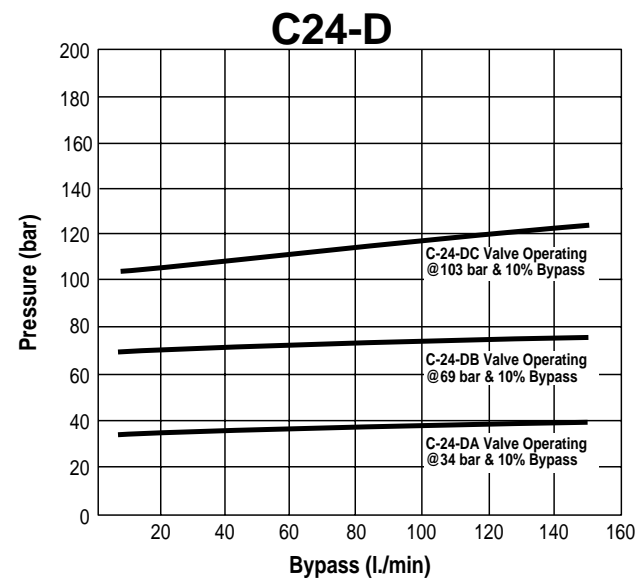
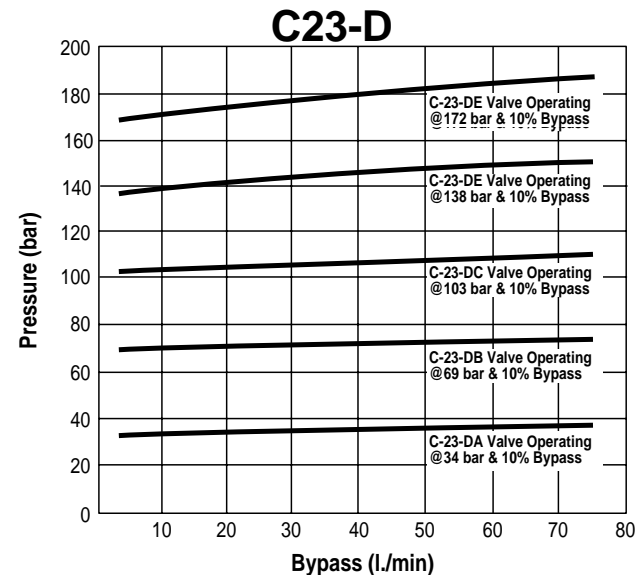
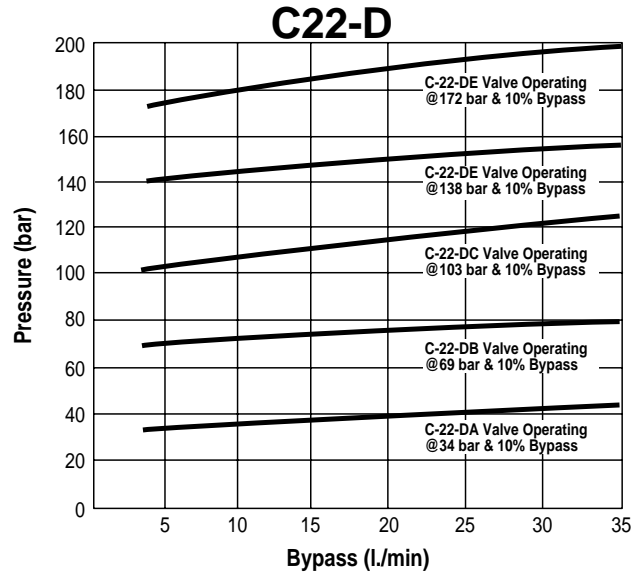

# C22/23/24-D Spring Disc Arrangement

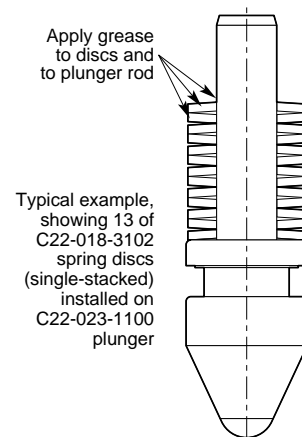
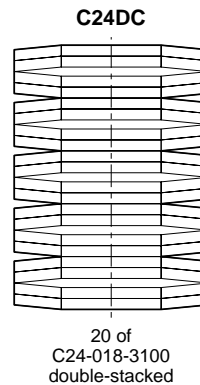
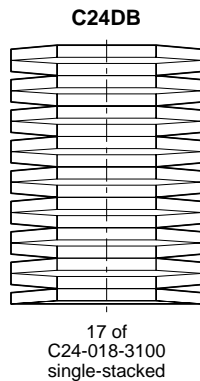
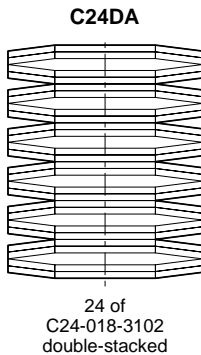
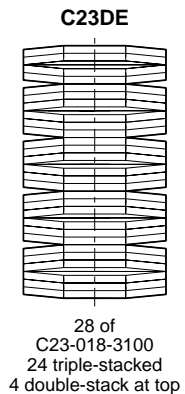
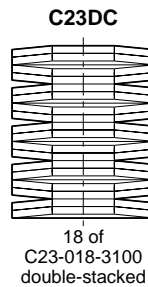
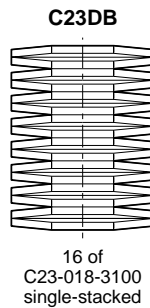
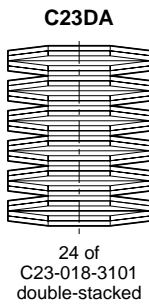
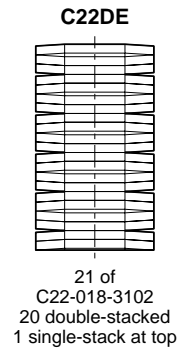
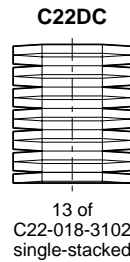
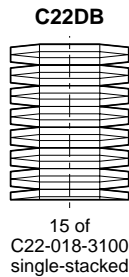
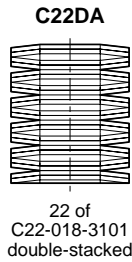

## Spring Disc Size and Arrangement

Valve Model	I./m	bar	Disc Size OD x ID x Thickness	Quantity Used
C-22-DA	11-38	5-34	20 x 10.2 x 0.8 mm	22 (double stack)
C-22-DB	11-38	34-69	20 x 10.2 x 1.2 mm	15 (single stack)
C-22-DC	11-38	69-103	20 x 10.2 x 1.5 mm	13 (single stack)
C-22-DE	11-38	103-172	20 x 10.2 x 1.5 mm	1 (single stack); 20 (double stack)
C-23-DA	11-76	5-34	28 x 12.2 x 1.0 mm	24 (double stack)
C-23-DB	11-76	34-69	28 x 12.2 x 1.5 mm	16 (single stack)
C-23-DC	11-76	69-103	28 x 12.2 x 1.5 mm	18 (double stack)
C-23-DC	11-76	103-172	28 x 12.2 x 1.5 mm	4 (double stack); 24 (triple stack)
C-24-DA	19-162	5-34	35.5 x 18.3 x 1.2 mm	24 (double stack)
C-24-DB	19-162	34-69	35.5 x 18.3 x 2.0 mm	17 (single stack)
C-24-DC	19-162	69-103	35.5 x 18.3 x 2.0 mm	20 (double stack)

# C22-D Parts

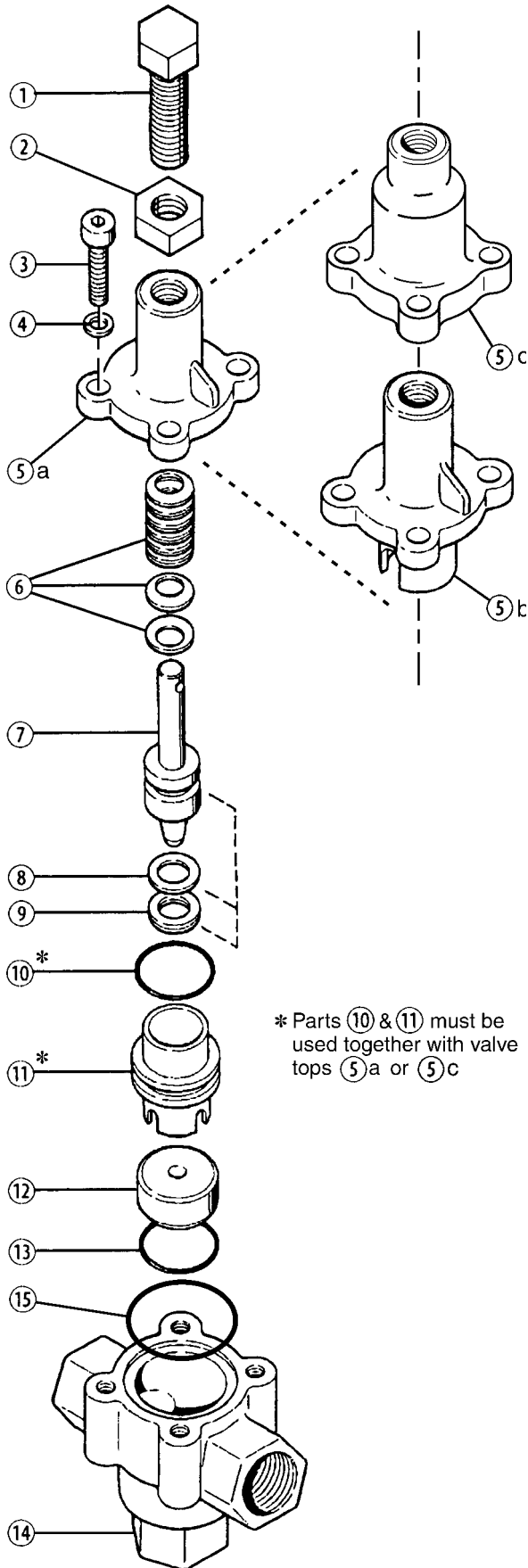

\* Parts ⑩ & ⑪ must be used together with valve tops ⑤a or ⑤c

C22-DA  
C22-DB  
C22-DC

## Brass Body

Ref #	Part Number	Description	Quantity/ Pump
1	C22-004-1005	Adjusting Bolt, Pressure Range A .....	1
	C22-004-1006	Adjusting Bolt, Pressure Range B, C ...	1
2	C22-005-1000	Jam Nut .....	1
3	C22-015-2004	Cap Screw, M8 x 1.25 x 25 mm .....	4
4	C22-014-2000	Lock Washer .....	4
5a	C22-003-1002	Valve Top, unwetted .....	1
5b	C22-003-1000	Valve Top, brass .....	1
6	C22-018-3100	Spring Disc, 20 x 10.2 x 1.2 mm .....	**
	C22-018-3101	Spring Disc, 20 x 10.2 x 0.8 mm .....	**
	C22-018-3102	Spring Disc, 20 x 10.2 x 1.5 mm .....	**
7	C22-023-1100	Plunger Assembly, 316 SST .....	1
	C22-023-1101	Plunger Assembly, SST, with tungsten carbide ball .....	1
	C22-023-1103	Plunger Assembly, 17-4 PH SST .....	1
	C22-023-1117	Plunger Assembly, Hastelloy C-276 ..	1
8	C22-013-2110	Seal, back-up, Buna .....	1
	C22-013-2117	Seal, back-up, UHMW polyethylene ...	1
	C22-013-2118	Seal, back-up, Teflon .....	1
9	C22-012-2110	Seal, Buna .....	1
	C22-012-2111	Seal, Viton .....	1
	C22-012-2113	Seal, EPDM .....	1
	C22-012-2115	Seal, urethane .....	1
10*	C22-011-2110	O-ring, sleeve, Buna .....	1
	C22-011-2111	O-ring, sleeve, Viton .....	1
	C22-011-2113	O-ring, sleeve, EPDM .....	1
11*	C22-024-1010	Sleeve, 316 SST .....	1
	C22-024-1017	Sleeve, Hastelloy C-276 .....	1
12	C22-006-1000	Seat, 316 SST .....	1
	C22-006-1001	Seat, 17-4 HT .....	1
	C22-006-1002	Seat, tungsten carbide .....	1
	C22-006-1017	Seat, Hastelloy C-276 .....	1
13	C22-010-2110	O-ring, valve seat, Buna .....	1
	C22-010-2111	O-ring, valve seat, Viton .....	1
	C22-010-2113	O-ring, valve seat, EPDM .....	1
14	C22-002-1006	Body, valve, brass, BSPT .....	1
15	C22-011-2110	O-ring, Buna .....	1
	C22-011-2111	O-ring, Viton .....	1
	C22-011-2113	O-ring, EPDM .....	1
-	C22-022-2400	Name Plate (specify model & serial no.) .....	1
-	A01-115-3400	Regulator Valve Spring Grease, 1/4 ounce .....	

\*\* See page 5 for spring disc quantities and arrangements.

# C22-D Parts

C22-DA  
C22-DB  
C22-DC

## Stainless Steel Body Nickel Alloy Body

Ref #	Part Number	Description	Quantity/ Pump
1	C22-004-1005	Adjusting Bolt, Pressure Range A .....	1
	C22-004-1006	Adjusting Bolt, Pressure Range B, C ...	1
2	C22-005-1000	Jam Nut .....	1
3	C22-015-2004	Cap Screw, M8 x 1.25 x 25 mm .....	4
4	C22-014-2000	Lock Washer .....	4
5a	C22-003-1002	Valve Top, nonwetted .....	1
6	C22-018-3100	Spring Disc, 20 x 10.2 x 1.2 mm .....	**
	C22-018-3101	Spring Disc, 20 x 10.2 x 0.8 mm .....	**
	C22-018-3102	Spring Disc, 20 x 10.2 x 1.5 mm .....	**
7	C22-023-1000	Plunger Assembly, 316 SST .....	1
	C22-023-1001	Plunger Assembly, SST, with tungsten carbide ball .....	1
	C22-023-1003	Plunger Assembly, 17-4 PH SST .....	1
	C22-023-1007	Plunger Assembly, Hastelloy C-276 ..	1
8	C22-013-2110	Seal, back-up, Buna .....	1
	C22-013-2117	Seal, back-up, UHMW polyethylene ...	1
	C22-013-2118	Seal, back-up, Teflon .....	1
9	C22-012-2110	Seal, Buna .....	1
	C22-012-2111	Seal, Viton .....	1
	C22-012-2113	Seal, EPDM .....	1
	C22-012-2115	Seal, urethane .....	1
10*	C22-016-2110	O-ring, sleeve, Buna .....	1
	C22-016-2111	O-ring, sleeve, Viton .....	1
	C22-016-2113	O-ring, sleeve, EPDM .....	1
11*	C22-024-1010	Sleeve, 316 SST .....	1
	C22-024-1017	Sleeve, Hastelloy C-276 .....	1
12	C22-006-1000	Seat, 316 SST .....	1
	C22-006-1001	Seat, 17-4 HT .....	1
	C22-006-1002	Seat, tungsten carbide .....	1
	C22-006-1017	Seat, Hastelloy C-276 .....	1
13	C22-010-2110	O-ring, valve seat, Buna .....	1
	C22-010-2111	O-ring, valve seat, Viton .....	1
	C22-010-2113	O-ring, valve seat, EPDM .....	1
14	C22-002-1004	Body, valve, 316 SST, BSPT .....	1
	C22-002-1018	Body, valve, nickel alloy C series, BSPT .....	1
15	C22-011-2110	O-ring, Buna .....	1
	C22-011-2111	O-ring, Viton .....	1
	C22-011-2113	O-ring, EPDM .....	1
-	C22-022-2400	Name Plate (specify model & serial no.) .....	1
-	A01-115-3400	Regulator Valve Spring Grease, 1/4 ounce .....	

\*\* See page 5 for spring disc quantities and arrangements.

C22-DE

## Brass Body Stainless Steel Body Nickel Alloy Body

Ref #	Part Number	Description	Quantity/ Pump
1	C22-004-1008	Adjusting Bolt, pressure range E .....	1
2	C22-005-1000	Jam Nut .....	1
3	C22-015-2014	Cap Screw, M8 x 1.25 x 25 mm .....	4
4	C22-014-2000	Lock Washer .....	4
5c	C22-003-1003	Valve Top, non-wetted, 172 bar .....	1
6	C22-018-3102	Spring Disc, 20 x 10.2 x 1.5 mm .....	21
7	C22-023-1000	Plunger Assembly, 316 SST .....	1
	C22-023-1003	Plunger Assembly, 17-4 PH SST .....	1
	C22-023-1007	Plunger Assembly, Hastelloy C-276 ..	1
8	C22-013-2110	Seal, back-up, Buna .....	1
	C22-013-2118	Seal, back-up, Teflon .....	1
9	C22-012-2110	Seal, Buna .....	1
	C22-012-2111	Seal, Viton .....	1
10*	C22-016-2110	O-ring, sleeve, Buna .....	1
	C22-016-2111	O-ring, sleeve, Viton .....	1
11*	C22-024-1010	Sleeve, 316 SST .....	1
	C22-024-1017	Sleeve, Hastelloy C-276 .....	1
12	C22-006-1000	Seat, 316 SST .....	1
	C22-006-1001	Seat, 17-4 HT .....	1
	C22-006-1017	Seat, Hastelloy C-276 .....	1
13	C22-010-2110	O-ring, valve seat, Buna .....	1
	C22-010-2111	O-ring, valve seat, Viton .....	1
14	C22-002-1006	Body, valve, brass, BSPT .....	1
	C22-002-1004	Body, valve, 316 SST, BSPT .....	1
	C22-002-1018	Body, valve, nickel alloy C series, BSPT .....	1
15	C22-011-2110	O-ring, Buna .....	1
	C22-011-2111	O-ring, Viton .....	1
-	C22-022-2400	Name Plate (specify model & serial no.) .....	1
-	A01-115-3400	Regulator Valve Spring Grease, 1/4 ounce .....	

# C23-D Parts

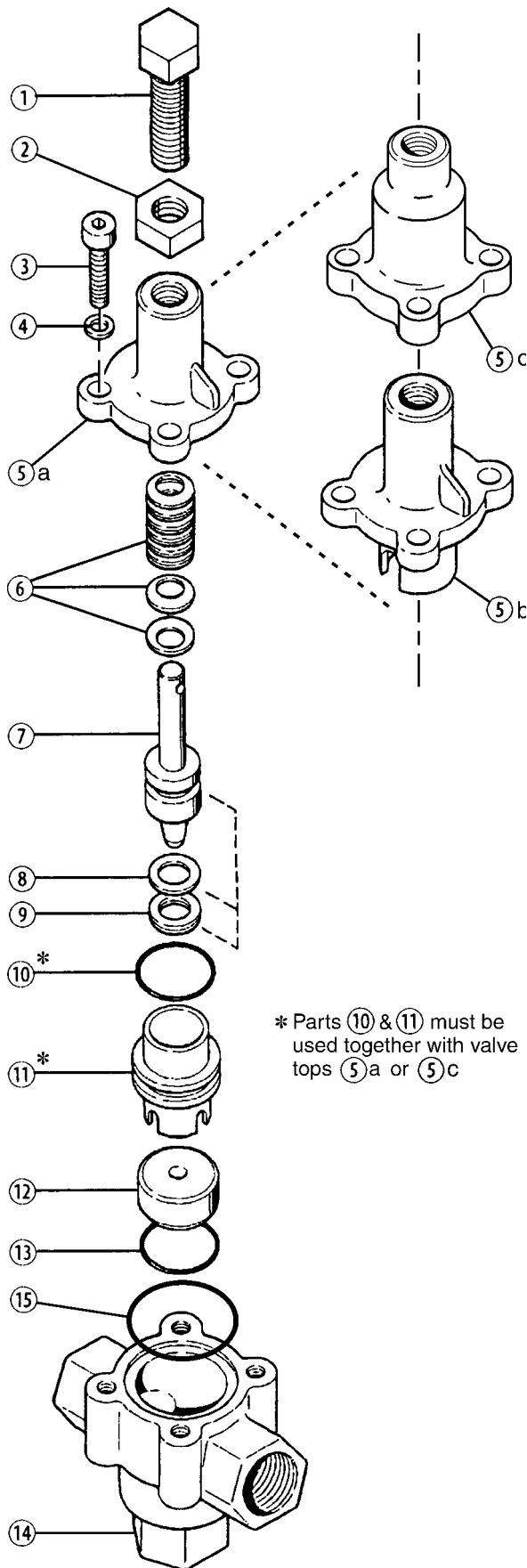

C23-DA  
C23-DB  
C23-DC

## Brass Body

Ref #	Part Number	Description	Quantity/ Pump
1	C23-004-1005	Adjusting Bolt, Pressure Range A .....	1
	C23-004-1006	Adjusting Bolt, Pressure Range B .....	1
	C23-004-1007	Adjusting Bolt, Pressure Range C .....	1
2	C23-005-1000	Jam Nut .....	1
3	G10-087-2010	Cap Screw, M10 x 1.5 x 30 mm .....	4
4	G25-048-2010	Lock Washer, M10 .....	4
5a	C23-003-1002	Valve Top, Nonwetted .....	1
5b	C23-003-1000	Valve Top, brass .....	1
6	C23-018-3100	Spring Disc, 28 x 12.2 x 1.5 mm .....	**
	C23-018-3101	Spring Disc, 28 x 12.2 x 1.0 mm .....	**
7	C23-023-1100	Plunger Assembly, 316 SST .....	1
	C23-023-1101	Plunger Assembly, SST, with tungsten carbide ball .....	1
	C23-023-1103	Plunger Assembly, 17-4 PH SST .....	1
	C23-023-1117	Plunger Assembly, Hastelloy C-276 ..	1
8	C23-013-2110	Seal, back-up, Buna .....	1
	C23-013-2117	Seal, back-up, UHMW polyethylene ...	1
	C23-013-2118	Seal, back-up, Teflon .....	1
9	C23-012-2110	Seal, Buna .....	1
	C23-012-2111	Seal, Viton .....	1
	C23-012-2113	Seal, EPDM .....	1
	C23-012-2115	Seal, urethane .....	1
10*	C23-016-2110	O-ring, sleeve, Buna .....	1
	C23-016-2111	O-ring, sleeve, Viton .....	1
	C23-016-2113	O-ring, sleeve, EPDM .....	1
11*	C23-024-1010	Sleeve, 316 SST .....	1
	C23-024-1017	Sleeve, Hastelloy C-276 .....	1
12	C23-006-1000	Seat, 316 SST .....	1
	C23-006-1001	Seat, 17-4 HT .....	1
	C23-006-1002	Seat, tungsten carbide .....	1
	C23-006-1017	Seat, Hastelloy C-276 .....	1
13	C23-010-2110	O-ring, valve seat, Buna .....	1
	C23-010-2111	O-ring, valve seat, Viton .....	1
	C23-010-2113	O-ring, valve seat, EPDM .....	1
14	C23-002-1006	Body, valve, brass, BSPT .....	1
15	C23-011-2110	O-ring, Buna .....	1
	C23-011-2111	O-ring, Viton .....	1
	C23-011-2113	O-ring, EPDM .....	1
-	C23-022-2400	Name Plate (specify model & serial no.) .....	1
-	A01-115-3400	Regulator Valve Spring Grease, 1/4 ounce .....	

\*\* See page 5 for spring disc quantities and arrangements.



# C23-D Parts

C23-DA  
C23-DB  
C23-DC

## Stainless Steel Body Nickel Alloy Body

Ref #	Part Number	Description	Quantity/ Pump
1	C23-004-1005	Adjusting Bolt, Pressure Range A .....	1
	C23-004-1006	Adjusting Bolt, Pressure Range B .....	1
	C23-004-1007	Adjusting Bolt, Pressure Range C .....	1
2	C23-005-1000	Jam Nut.....	1
3	G10-087-2010	Cap Screw, M10 x 1.5 x 30 mm .....	4
4	G25-048-2010	Lock Washer, M10 .....	4
5a	C23-003-1002	Valve Top. Nonwetted .....	1
6	C23-018-3100	Spring Disc, 28 x 12.2 x 1.5 mm .....	**
	C23-018-3101	Spring Disc, 28 x 12.2 x 1.0 mm .....	**
7	C23-023-1100	Plunger Assembly, 316 SST .....	1
	C23-023-1101	Plunger Assembly, SST, with tungsten carbide ball .....	1
	C23-023-1103	Plunger Assembly, 17-4 PH SST .....	1
7	C23-023-1117	Plunger Assembly, Hastelloy C-276 ..	1
8	C23-013-2110	Seal, back-up, Buna .....	1
	C23-013-2117	Seal, back-up, UHMW polyethylene ...	1
	C23-013-2118	Seal, back-up, Teflon .....	1
9	C23-012-2110	Seal, Buna .....	1
	C23-012-2111	Seal, Viton .....	1
	C23-012-2113	Seal, EPDM .....	1
	C23-012-2115	Seal, urethane .....	1
10*	C23-011-2110	O-ring, sleeve, Buna .....	1
	C23-011-2111	O-ring, sleeve, Viton .....	1
	C23-011-2113	O-ring, sleeve, EPDM .....	1
11*	C23-024-1010	Sleeve, 316 SST .....	1
	C23-024-1017	Sleeve, Hastelloy C-276 .....	1
12	C23-006-1000	Seat, 316 SST .....	1
	C23-006-1001	Seat, 17-4 HT .....	1
	C23-006-1002	Seat, tungsten carbide .....	1
	C23-006-1017	Seat, Hastelloy C-276 .....	1
13	C23-010-2110	O-ring, valve seat, Buna .....	1
	C23-010-2111	O-ring, valve seat, Viton .....	1
	C23-010-2113	O-ring, valve seat, EPDM .....	1
14	C23-002-1004	Body, valve, 316 SST, BSPT .....	1
	C23-002-1018	Body, valve, nickel alloy C series, BSPT .....	1
15	C23-011-2110	O-ring, Buna .....	1
	C23-011-2111	O-ring, Viton .....	1
	C23-011-2113	O-ring, EPDM .....	1
-	C23-022-2400	Name Plate (specify model & serial no.) .....	1
-	A01-115-3400	Regulator Valve Spring Grease, 1/4 ounce .....	

\*\* See page 5 for spring disc quantities and arrangements.

C23-DE

## Brass Body Stainless Steel Body Nickel Alloy Body

Ref #	Part Number	Description	Quantity/ Pump
1	C23-004-1008	Adjusting Bolt, Pressure Range E .....	1
2	C23-005-1000	Jam Nut.....	1
3	G03-068-2010	Cap Screw, M10 x 1.5 x 40 mm .....	4
4	G25-048-2010	Lock Washer, M10 .....	4
5c	C23-003-1003	Valve Top, brass, 172 bar .....	1
6	C23-018-3100	Spring Disc, 28 x 12.2 x 1.5 mm .....	28
7	C23-023-1100	Plunger Assembly, 316 SST .....	1
	C23-023-1103	Plunger Assembly, 17-4 PH SST .....	1
	C23-023-1117	Plunger Assembly, Hastelloy C-276 ..	1
8	C23-013-2110	Seal, back-up, Buna .....	1
	C23-013-2118	Seal, back-up, Teflon .....	1
9	C23-012-2110	Seal, Buna .....	1
	C23-012-2111	Seal, Viton .....	1
10*	C23-016-2110	O-ring, sleeve, Buna .....	1
	C23-016-2111	O-ring, sleeve, Viton .....	1
11*	C23-024-1010	Sleeve, 316 SST .....	1
	C23-024-1017	Sleeve, Hastelloy C-276 .....	1
12	C23-006-1000	Seat, 316 SST .....	1
	C23-006-1001	Seat, 17-4 HT .....	1
	C23-006-1017	Seat, Hastelloy C-276 .....	1
13	C23-010-2110	O-ring, valve seat, Buna .....	1
	C23-010-2111	O-ring, valve seat, Viton .....	1
14	C23-002-1006	Body, valve, brass, BSPT .....	1
	C23-002-1004	Body, valve, 316 SST, BSPT .....	1
	C23-002-1018	Body, valve, nickel alloy C series, BSPT .....	1
15	C23-011-2110	O-ring, Buna .....	1
	C23-011-2111	O-ring, Viton .....	1
-	C23-022-2400	Name Plate (specify model & serial no.) .....	1
-	A01-115-3400	Regulator Valve Spring Grease, 1/4 ounce .....	

# C24-D Parts

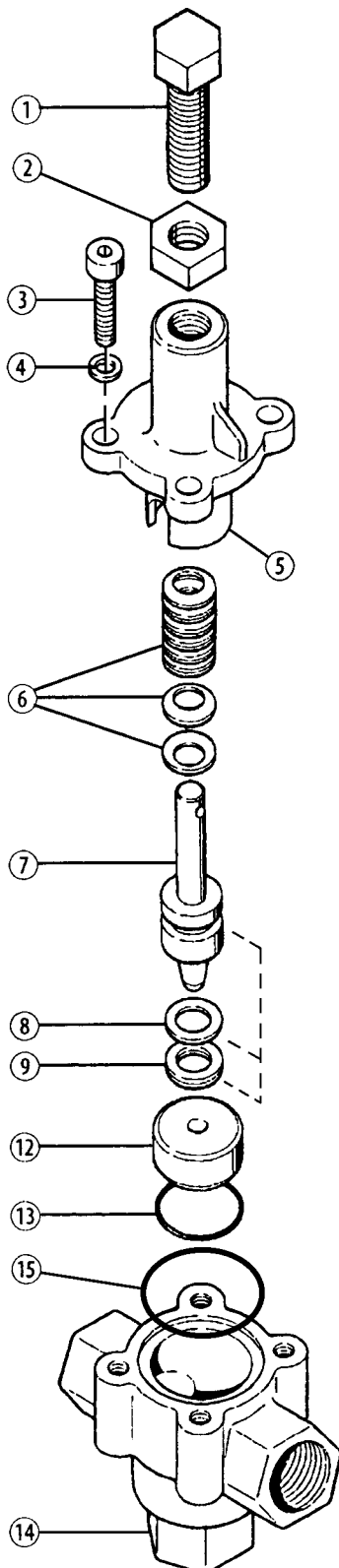

C24-DA  
C24-DB  
C24-DC

## Brass Body Stainless Steel Body Nickel Alloy Body

Ref #	Part Number	Description	Quantity/ Pump
1	C24-004-1005	Adjusting Bolt, Pressure Range A .....	1
	C24-004-1006	Adjusting Bolt, Pressure Range B .....	1
	C24-004-1007	Adjusting Bolt, Pressure Range C .....	1
2	C24-005-1000	Jam Nut.....	1
3	G35-081-2010	Cap Screw, M12 x 1.75 x 40 mm .....	4
4	G35-084-2010	Lock Washer, M12 .....	4
5	C24-003-1000	Valve Top, brass .....	1
	C24-003-1001	Valve Top, 316 SST .....	1
	C24-003-1002	Valve Top, nickel alloy C series .....	1
6	C24-018-3100	Spring Disc, 35.5 x 18.3 x 2.0 mm ...	**
	C24-018-3102	Spring Disc, 35.5 x 18.3 x 1.2 mm ...	**
7	C24-023-1100	Plunger Assembly, 316 SST .....	1
	C24-023-1101	Plunger Assembly, SST, with tungsten carbide ball .....	1
	C24-023-1102	Plunger Assembly, Hastelloy C-276 ..	1
8	C24-023-1103	Plunger Assembly, 17-4 PH SST .....	1
	C24-013-2110	Seal, back-up, Buna .....	1
	C24-013-2118	Seal, back-up, Viton .....	1
9	C24-012-2110	Seal, Buna .....	1
	C24-012-2111	Seal, Viton, .....	1
	C24-012-2113	Seal, EPDM .....	1
12	C24-006-1000	Seat, 316 SST .....	1
	C24-006-1001	Seat, 17-4 HT .....	1
	C24-006-1002	Seat, tungsten carbide .....	1
	C24-006-1003	Seat, Hastelloy C-276 .....	1
13	C23-010-2110	O-ring, valve seat, Buna .....	1
	C23-010-2111	O-ring, valve seat, Viton .....	1
	C23-010-2113	O-ring, valve seat, EPDM .....	1
14	C24-002-1006	Body, valve, brass, BSPT .....	1
	C24-002-1007	Body, valve, 316 SST, BSPT .....	1
	C24-002-1008	Body, valve, nickel alloy C series, BSPT .....	1
15	C24-011-2110	O-ring, Buna .....	1
	C24-011-2111	O-ring, Viton .....	1
	C24-011-2113	O-ring, EPDM .....	1
-	C24-022-2400	Name Plate (specify model & serial no.) .....	1
-	A01-115-3400	Regulator Valve Spring Grease, 1/4 ounce .....	

\*\* See page 5 for spring disc quantities and arrangements.

# C22/23/24-D Repair

---

The valve can generally be repaired in place, without removing it from the system.

When disassembling, note the number of spring discs and their arrangement. They must be reinstalled in the same arrangement (refer also to page 5 — note that they are stacked, either singly or in pairs, facing in alternate directions). When reassembling, apply liberal amounts of high-temperature regulator grease (Wanner #A01-115-3400) on the springs and around the plunger stem.

The seal (9) and back-up seal (8) must be replaced together; don't replace one without replacing the other.

# C22/23/24-D Troubleshooting

---

## Excess Pressure Required to Bypass Fluid

- Regulating valve pressure not properly adjusted
- Not enough fluid being continuously bypassed
- Nozzles worn

## Fluid Leaking from Hole in Valve Top

- Worn Seals

## System Losing Pressure

- Nozzles worn
- Pump RPM reduced
- Regulating valve pressure not properly adjusted
- Worn pump components
- Worn regulating valve seat or plunger
- System drawing in air
- Too much fluid being bypassed

## Pressure Spikes

- Minimum bypass of 10% not being maintained
- Nozzles worn
- Regulating valve pressure not properly adjusted

### **Limited Warranty**

Wanner Engineering, Inc. extends to the original purchaser of equipment manufactured by it and bearing its name, a limited one-year warranty from the date of purchase against defects in material or workmanship, provided that the equipment is installed and operated in accordance with the recommendations and instructions of Wanner Engineering, Inc. Wanner Engineering, Inc. will repair or replace, at its option, defective parts without charge if such parts are returned with transportation charges prepaid to Wanner Engineering, Inc., 1204 Chestnut Avenue, Minneapolis, Minnesota 55403.

This warranty does not cover:

1. The electric motors (if any), which are covered by the separate warranties of the manufacturers of these components.
2. Normal wear and/or damage caused by or related to abrasion, corrosion, abuse, negligence, accident, faulty installation or tampering in a manner which impairs normal operation.
3. Transportation costs.

This limited warranty is exclusive, and is in lieu of any other warranties (express or implied) including warranty of merchantability or warranty of fitness for a particular purpose and of any noncontractual liabilities including product liabilities based on negligence or strict liability. Every form of liability for direct, special, incidental or consequential damages or loss is expressly excluded and denied.



**WANNER ENGINEERING, INC.**

1204 Chestnut Avenue, Minneapolis, MN 55403  
TEL: (612) 332-5681 FAX: (612) 332-6937  
TOLL-FREE FAX [US only]: (800) 332-6812

www.hydra-cell.com  
email: sales@wannereng.com