

**DIU SERIES ROUND HUB
ROTARY GEAR PUMPS
SIZES 1, 3, 5, 6, 7, 8 & 9**

Haight offers seven sizes of pumps in the round hub DIU Series. All sizes are available with an optional bolt-on relief valve which can function in either the return to suction, or return to tank mode.

Compact rugged, and easy to maintain, these pumps are ideally suited to close-coupled mounting, or direct mounting to the motor

Series DIU Round Hub Pumps feature:

- operate at standard motor speeds, eliminating the need for pulleys/gear reducers
- involute gear design offers excellent suction characteristics, minimizes noise and reduces internal bypassing
- self-lubricating gramix iron bearings
- easy to maintain Buna-N lip seals. Installed in the UniverSeal design for simple and quick replacement, or change to alternate seal style.
- optional mounting brackets which are designed for in-line mounting with standard NEMA frame size motors or bedplate mounting.
- * optional bearing, rotor and seal materials which allow effective operation up to 620°F and 600 psi. (*Contact Factory)



5U pump with motor

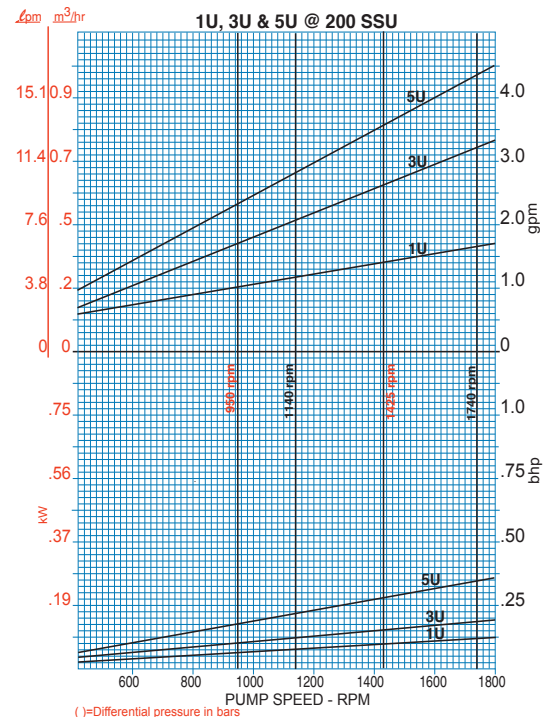

Z56RO Bracket for 1-8 GPM Round Hub Pumps

MODEL	A	B	D	E	F	G	H	J	K
	1U	7 13/16	5-15/16						
3U	7 13/16	5-15/16							
5U	8	5-15/16							
6U	8 5/16	6							
8U	8 7/16	6							
FRAME	48		9 3/8	3	2 13/16	2 1/8	1 3/8	2 5/16	5 13/16
	56		9 3/4	3 1/2	3 5/16	2 7/16	1 1/2	2 9/16	6 3/4

D Dimension will vary with motor enclosure

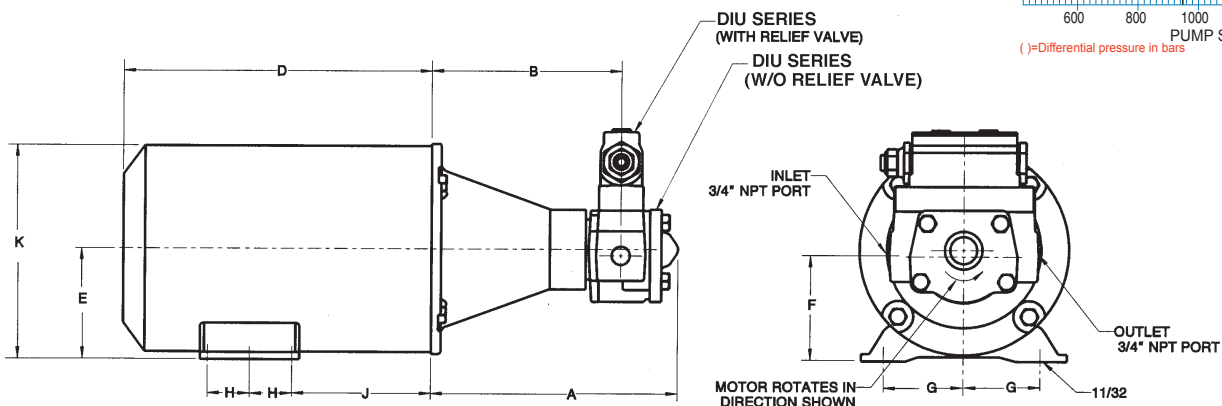

For more information contact:

Haight Pumps 133 Enterprise Street • Evansville, WI 53536 Phone: 800-871-9250 • Fax: 608-882-3777

Website: haightpump.com