

DIU SERIES 120-240 GPM ROTARY GEAR PUMPS

The First Release of the New Large Flow DIU Series Pumps

Haight Pump is proud to announce the new large flow DIU series pumps. The “Universal” design has been extended to handle flow rates from 120-240 gpm! Flexible, quick, and incredibly reliable; everything you have come to expect from Haight Pump.

Key Features:

- ❑ 3 sizes ranging from 120 gpm to 240 gpm
- ❑ Built in Shaft Seal Flexibility
- ❑ Less moving Parts reduces Maintenance and Wear
- ❑ Close Coupled design eliminates shaft mis-alignment and related failures
- ❑ 250 PSI Discharge Pressure Capability
- ❑ 300# ANSI Flange; Inlet & Outlet Ports
- ❑ “Gear within a Gear” design for quiet operation
- ❑ Direct Drive - speeds to 1800 RPM

Standard Construction Features:

- Ductile Iron Housing
- Steel Shaft and Pinion Gears
- Iron Rotor and Bearings
- Buna N Lip Seals and Elastomers

Options:

- Alternate Shaft Seal and O-ring Elastomer Materials
– Neoprene, Silicone, Teflon or Viton
- Lip seals
- Type 21, 2B, and 2 mechanical seals
- Venting options include: clockwise, counter-clockwise, and bi-rotational
- Optional Relief Valve

Applications:

- Petroleum Products (fuel transfer/bulk transfer)
- Lubrication Systems • Food Processing • Soap
- Detergent Products • Paper Products • Ship building
- Mining

120U Pump with Z184 Bracket

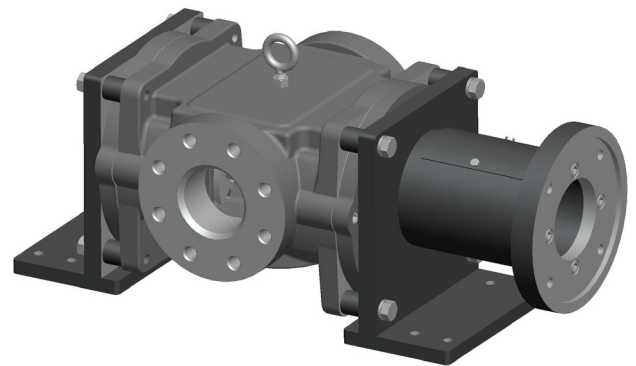

120U Dimensional Drawing

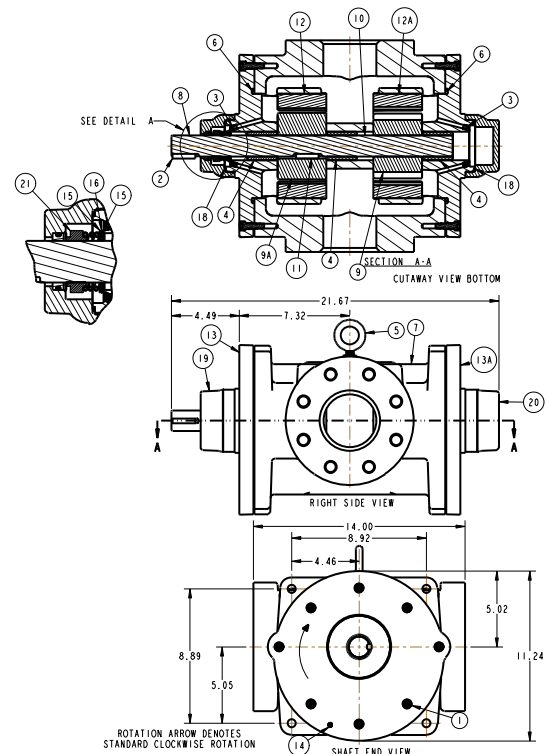

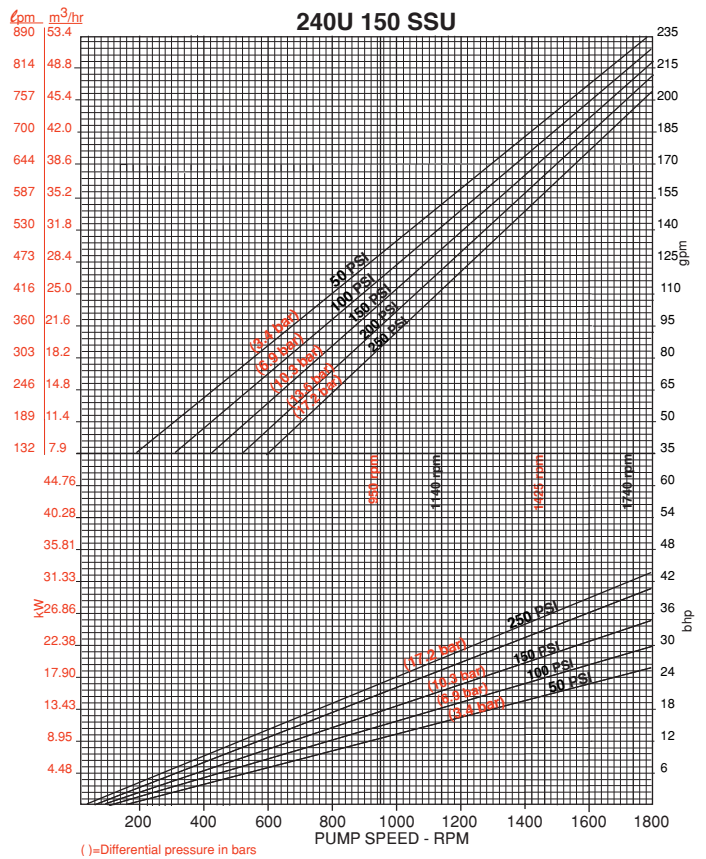
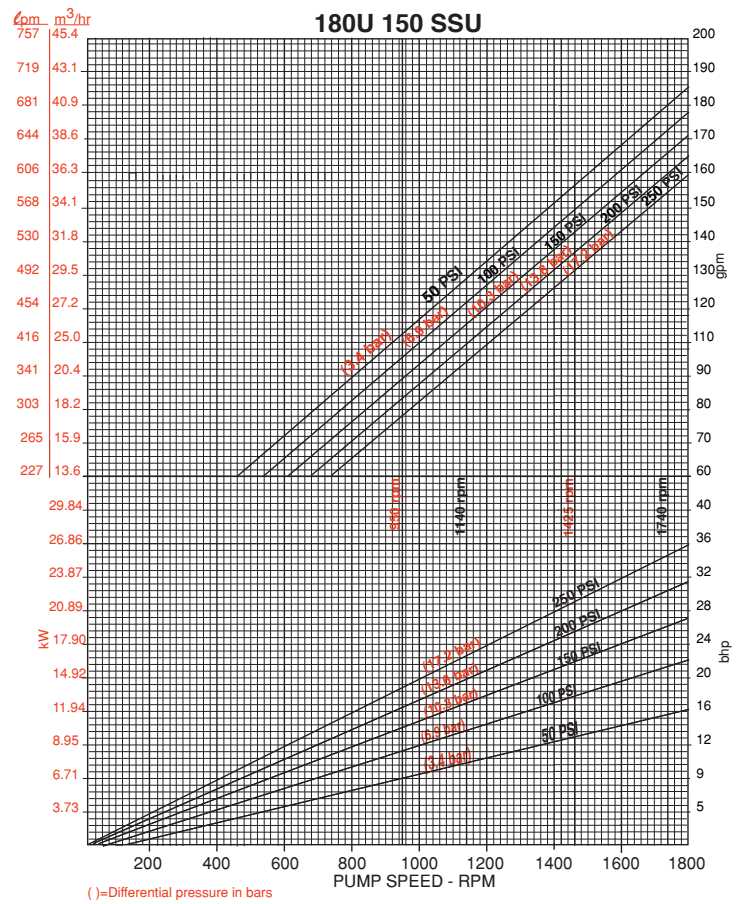
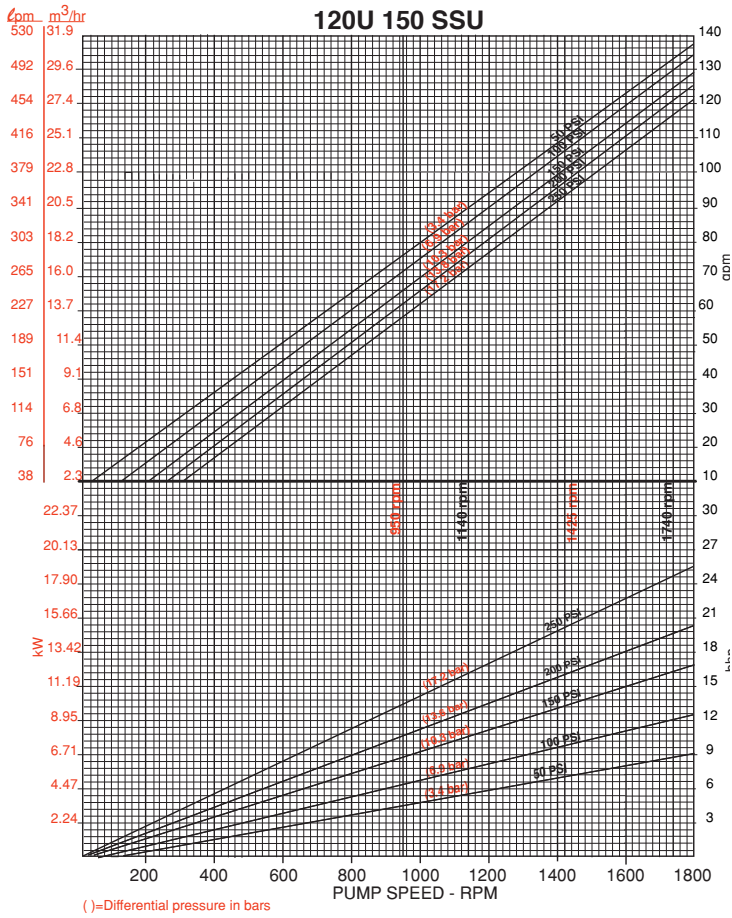

additional sizes and flow rates available upon request.