

## DIU SERIES 120-240 GPM ROTARY GEAR PUMPS

### *The First Release of the New Large Flow DIU Series Pumps*

Haight Pump is proud to announce the new large flow DIU series pumps. The “Universal” design has been extended to handle flow rates from 120-240 gpm! Flexible, quick, and incredibly reliable; everything you have come to expect from Haight Pump.

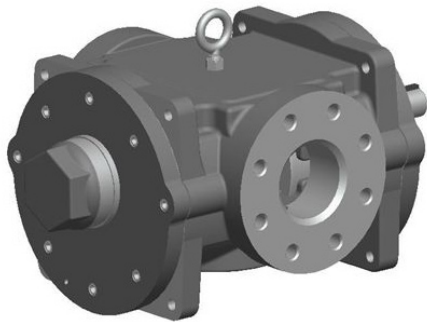

### *Standard Construction Features:*

- Ductile Iron Housing
- Steel Shaft and Pinion Gears
- Iron Rotor and Bearings
- Buna N Lip Seals and Elastomers

### *Options:*

- Alternate Shaft Seal and O-ring Elastomer Materials – Neoprene, Silicone, Teflon or Viton
- Lip seals
- Type 21, 2B, and 2 mechanical seals
- Venting options include: clockwise, counter-clockwise, and bi-rotational
- Optional Relief Valve

### *Applications:*

- Petroleum Products (fuel transfer/bulk transfer)
- Lubrication Systems • Food Processing • Soap
- Detergent Products • Paper Products • Ship building
- Mining

### *Key Features:*

- ❑ 3 sizes ranging from 120 gpm to 240 gpm
- ❑ Built in Shaft Seal Flexibility
- ❑ Less moving Parts reduces Maintenance and Wear
- ❑ Close Coupled design eliminates shaft mis-alignment and related failures
- ❑ 250 PSI Discharge Pressure Capability
- ❑ 300# ANSI Flange; Inlet & Outlet Ports
- ❑ “Gear within a Gear” design for quiet operation
- ❑ Direct Drive - speeds to 1800 RPM

NEW Sizes Now Available	
120 GPM	
180 GPM	
240 GPM	

Other Sizes Available		
1 GPM	10 GPM	44 GPM
3 GPM	15 GPM	54 GPM
5 GPM	20 GPM	60 GPM
7 GPM	24 GPM	70 GPM
8 GPM	30 GPM	80 GPM
9 GPM	40 GPM	

For more information contact:

Haight Pumps 133 Enterprise Street • Evansville, WI 53536 Phone: 800-871-9250 • Fax: 608-882-3777  
Website: [haightpump.com](http://haightpump.com)

# APPLICATION SOLUTIONS BY TYPES OF SYSTEMS

Application Category	Typical Applications	Application Specific Adaptations
<b>Refrigeration Systems</b>	<ul style="list-style-type: none"> <li>• High pressure compressor lubrication</li> <li>• Liquefied refrigerant circulation</li> </ul>	<ul style="list-style-type: none"> <li>• Custom mounting</li> <li>• Contaminated lubricants</li> <li>• High inlet pressures</li> <li>• High pressure/thin fluid conditions</li> <li>• Custom seal configurations</li> </ul>
<b>Lubrication Systems</b>	<ul style="list-style-type: none"> <li>• Shipboard systems</li> <li>• Power transmission systems</li> <li>• Conveyor systems</li> <li>• Generator systems</li> <li>• Compressors</li> <li>• CNC machinery</li> <li>• Forming machinery</li> <li>• Lubricant cooling systems</li> </ul>	<ul style="list-style-type: none"> <li>• Corrosion resistant designs</li> <li>• Custom mounting</li> <li>• Special direct drive designs</li> <li>• Double pump designs</li> </ul>
<b>Filtration Systems</b>	<ul style="list-style-type: none"> <li>• Electric transformers</li> <li>• Cooking oil</li> <li>• Fuels</li> <li>• Hydraulic fluids</li> <li>• Lubrication products</li> <li>• Machine tool coolants</li> <li>• Process stream by-products</li> </ul>	<ul style="list-style-type: none"> <li>• High inlet vacuum designs</li> <li>• Special seals</li> <li>• Hardened and corrosion resistant construction</li> <li>• High temperature designs</li> <li>• Special pump designs</li> </ul>
<b>Fueling</b>	<ul style="list-style-type: none"> <li>• Aircraft refueling systems</li> <li>• Portable refueling systems</li> <li>• Engine or remote mounted fuel systems</li> </ul>	<ul style="list-style-type: none"> <li>• Direct drive</li> <li>• DC drive</li> <li>• Pneumatic drive</li> <li>• Hydraulic drive</li> <li>• Custom mounting</li> <li>• Special sealing designs</li> </ul>
<b>Injection Systems</b>	<ul style="list-style-type: none"> <li>• Expandable foams</li> <li>• Resins</li> <li>• Adhesives</li> <li>• Hot tar</li> <li>• Thin film lubrication for metal forming</li> <li>• Agricultural chemicals</li> <li>• Animal feed supplements</li> </ul>	<ul style="list-style-type: none"> <li>• Custom mounting designs</li> <li>• Hardened and corrosion resistant designs</li> <li>• High temperature conditions</li> <li>• Tractor and truck mounted PTO drives</li> </ul>
<b>Marine</b>	<ul style="list-style-type: none"> <li>• Main engine and drive train lubrication</li> <li>• Loading and unloading fuel &amp; lubrication products</li> <li>• Salt water wash-down systems</li> <li>• Winch lubrication</li> <li>• Fish processing waste</li> <li>• Bilge scavenging pumps</li> <li>• Aircraft/helicopter refueling systems</li> </ul>	<ul style="list-style-type: none"> <li>• Custom mounting and drive designs</li> <li>• Corrosion resistant materials</li> <li>• Spark resistant construction</li> </ul>
<b>Power Transmissions</b>	<ul style="list-style-type: none"> <li>• Gear box bearing and gear lubrication</li> <li>• Transmission lubrication</li> <li>• Drive shaft bearing lubrication</li> <li>• Lubricant cooling systems</li> <li>• Lubricant filtration</li> </ul>	<ul style="list-style-type: none"> <li>• Custom mounting and drive designs</li> </ul>
<b>Thermal Processing</b>	<ul style="list-style-type: none"> <li>• High temperature circulation</li> <li>• High temperature filtration</li> </ul>	<ul style="list-style-type: none"> <li>• Special construction features for elevated temperature operations</li> </ul>
<b>API Type Application</b>	<ul style="list-style-type: none"> <li>• Tank battery circulation</li> <li>• Sampling systems</li> <li>• LAC systems</li> <li>• Intermediate pressure pipeline transfer</li> </ul>	