

RV SERIES MARINE AND INDUSTRIAL HEAT EXCHANGERS

THE CONCEPT



**RV SERIES
OIL COOLERS**

Since the 1930's GROCO® has manufactured heat exchangers (oil coolers) for the most demanding military, marine and industrial customers. Cast bronze construction and universal mounting (body may be rotated to simplify plumbing) make these the finest heat exchangers available.

At engine start-up a built-in bypass system allows cold oil to flow past the heat exchanger until operating temperature is reached. The full flow of oil is then directed between the cooling tubes.

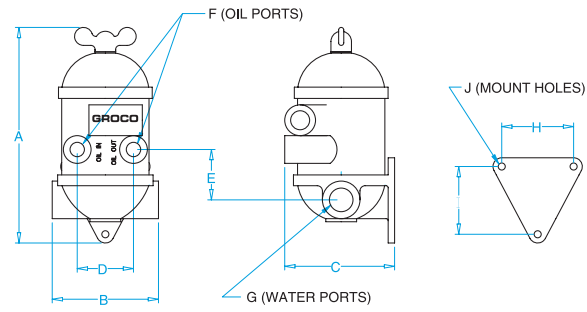

BODY MAY BE ROTATED 360-DEGREES

MODEL	A	B	C	D	E	F (OIL) NPT	G (WATER) NPT	H	I	J	WEIGHT	AREA	PKG
RV-20-250	6.13	3.38	2.38	1.69	1.63	1/4	1/2	-	-	.88	5.0#	305 Sq In	1
RV-20-375	6.13	3.38	2.38	1.69	1.63	3/8	1/2	-	-	.88	5.0#	305 Sq In	1
RV-25-375	8.00	4.38	3.41	1.75	1.31	3/8	3/4	-	-	1.13	6.5#	415 Sq In	1
RV-25-500	8.00	4.38	3.41	1.75	1.31	1/2	3/4	-	-	1.13	6.5#	415 Sq In	1
RV-26-500	10.50	5.13	5.44	2.75	2.44	1/2	1	1.81	1.44	2.69	17.0#	433 Sq In	1
RV-27-500	12.00	5.13	5.44	2.75	2.44	1/2	1	1.81	1.44	2.69	20.0#	561 Sq In	1
RV-27-750	12.00	5.13	5.44	2.75	2.44	3/4	1	1.81	1.44	2.69	20.0#	561 Sq In	1
RV-29-750	14.50	7.13	7.44	3.50	2.81	3/4	1-1/2	2.31	2.69	3.88	35.0#	1164 Sq In	1
RV-29-1000	14.50	7.13	7.44	3.50	2.81	1	1-1/2	2.31	2.69	3.88	35.0#	1164 Sq In	1

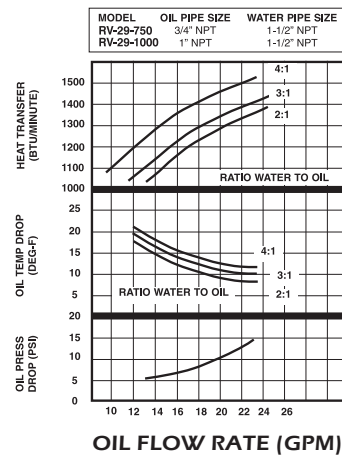
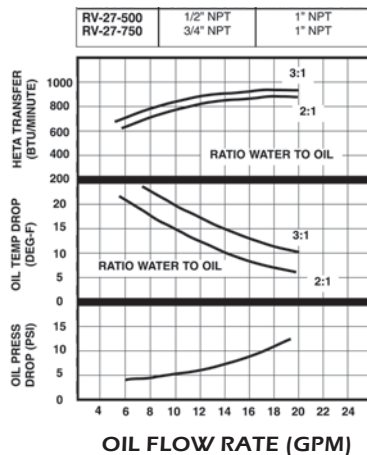
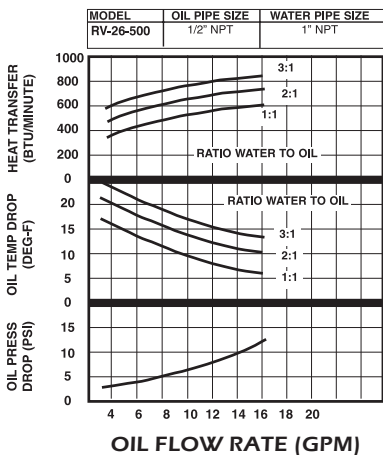
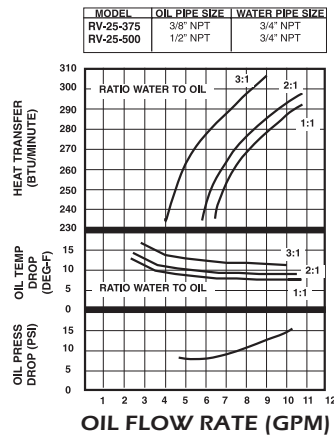
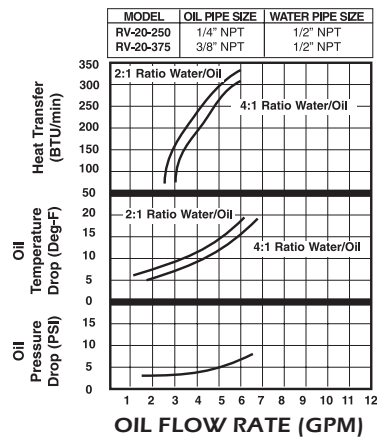

OIL COOLERS / HEAT EXCHANGERS