

# CP-20-S Centrifugal Circulator Pump

## Installation, Operation, and Maintenance

**The Concept:** CP-20-S is a submersible centrifugal pump designed for use in fresh or salt water (hot or cold) circulating systems. Construction is of bronze, stainless steel, or is non-metallic, so the pump may be used to pump nearly any non flammable, non-explosive liquid.

**Installation:** Install the pump in a location that will provide generous air flow to aid in motor cooling.

CP-20-S is not self-priming, so a flooded inlet is required. You may lay CP-20-S on its side in the bilge, running inlet and discharge hoses to and from the pump.

Because of the weight of the pump, installation directly on top of a seacock is not recommended unless the pump is supported with straps or clamps.

**Bonding:** GROCO pumps must be connected to the vessel bonding system. Use 14-gauge (or larger) stranded copper wire and a ring terminal beneath one of the bolts that holds the pump castings together to make this connection.

**Warning:** Motorized equipment must have a separate connection to the vessel DC grounding bus in accordance with ABYC, E-11, Figure-18. DO NOT make pump bonding connection in series with non-motorized equipment such as strainers or seacocks.

**Plumbing:** Make plumbing connections with pipe, hose, or pipe-to-hose adaptors. Double clamp hose connections and use TFE thread tape on pipe connections.

The inlet is 3/4" NPT and the discharge is threaded internally 1/2" NPT, or 1" ID hose may be used. An adaptor is included for garden hose.

Avoid sharp bends and sage in plumbing lines, and use full-flow fittings and hose if possible.

**Electrical:** Proper wire size is essential for proper motor and pump performance. Refer to the wire size selection chart enclosed.

The orange wire is positive (+). Make electrical connections with marine grade crimp terminals.

**Operation:** Consider controlling operation with GROCO Pump Cycle Timer PC-10 or FPC-10

**Maintenance:** No regular maintenance is required.

**Winterization:** Freezing water within will damage the pump. Close the inlet seacock and disconnect the connecting fittings or hose to drain water.



CP-20-S is fully submersible

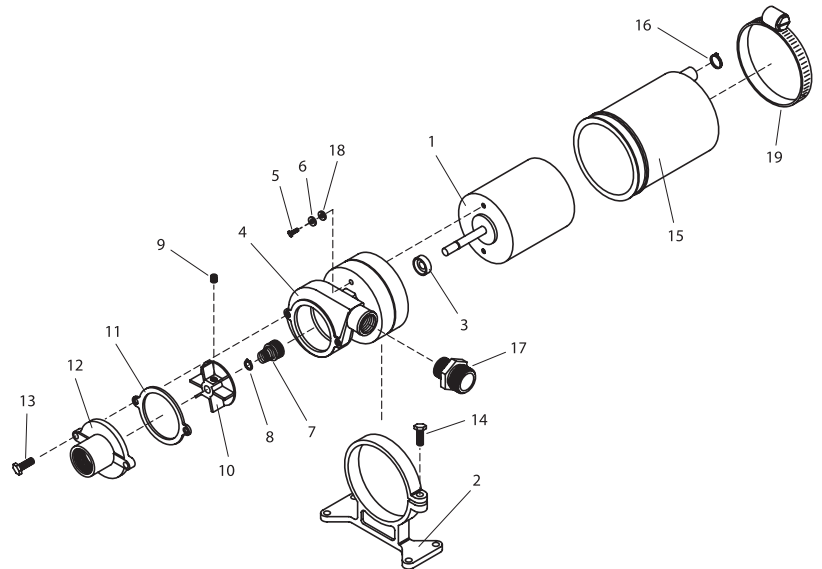

Item	Part Number	Part Name	Qty	Service Kit
1	(voltage)-B	Motor (CP-20 Series)	1	
	(voltage)-M	Motor (CP-30 Series)	1	
NS	24137901	Brushes (M series)	1	
2	CP-21-S	Bracket	1	
3	031-075-8	Seal	1	*
4	CP-20-S	Housing	1	
5	1032X12HS	Screw	2	
6	10L	Washer	2	
7	69026	Seal Assy	1	*
8	Snap Ring-1	Snap Ring	1	*
9	14X14SET	Set Screw	1	
10	CP-55	Impeller & Set Screw	1	
11	CP-56	Gasket	1	*
12	CP-58-H	Cover	1	
13	1420X34HS	Screw	2	
14	1420X1FB	Screw	1	
15	SBP-204	Boot	1	
16	GS-4-SS	Clamp	1	
17	GHM500M	1/2 NPT x GH Adaptor	1	
18	PFW-K	Washer	2	
19	CLAMP-7	Clamp	1	
	P-2			*