



e-SV Series Vertical Multistage Pumps

60 HZ TECHNICAL MANUAL

Intellitronic X

Intellitronic X is pump solution software with multiple search options and helpful project management facilities.

Intellitronic X can be available: at www.gouldsintellitronic.com

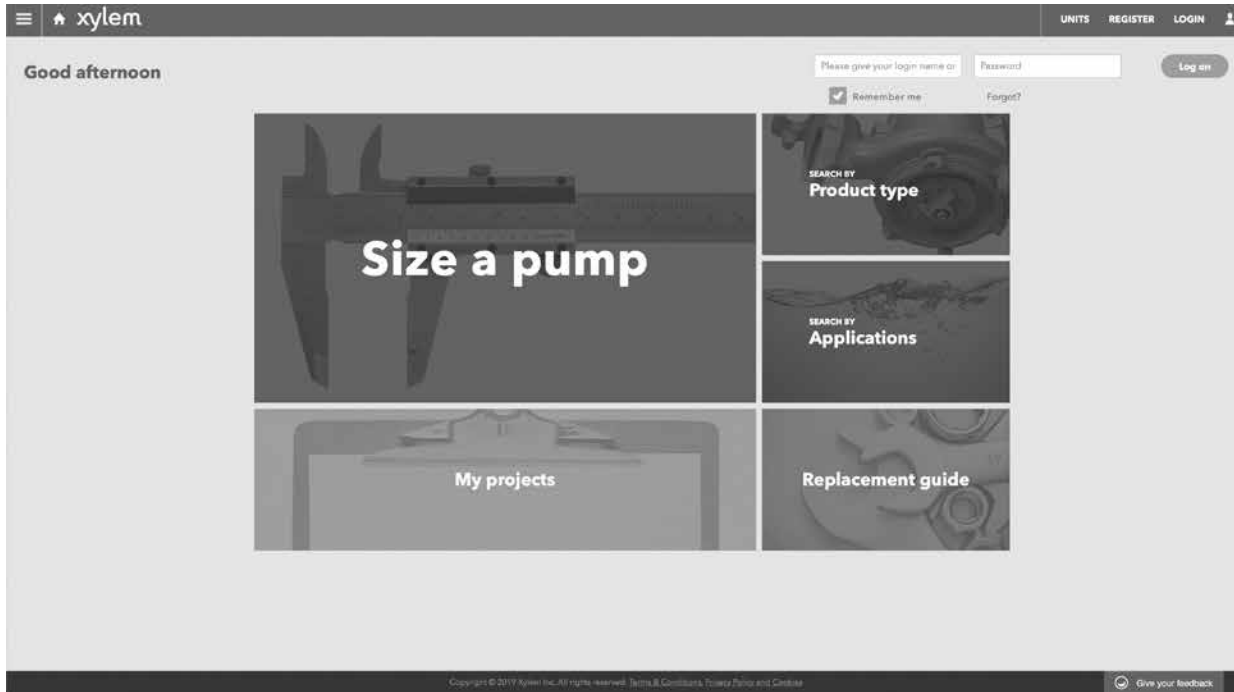

Contents

Coverage Curves	4
General Market Specifications	5
Characteristics of 1-22SV Series	6
Characteristics of 33-125SV Series	6
General Characteristics	7
Typical Applications of e-SV Pumps	8
e-SV Nomenclature	9-12
1-22SV Series Pump Cross Section and Main Components	13-14
33-92SV Series Pump Cross Section and Main Components	15-16
125SV Series Pump Cross Section and Main Components	17-18
e-SV Mechanical Seals	19
Maximum Allowable Working Pressure Charts	20
3500 rpm Curves, Dimensions and Weights	21-42
1750 rpm Curves, Dimensions and Weights	43-64
Horizontal Mounting Options	65-68
Table of Hydraulic Performances at 3500 rpm	69-74
Table of Hydraulic Performances at 1750 rpm	75-80
Packaged e-SV Hydrovar Series	81-104
e-SVE Series	105-133
Technical Appendix	134-139

e-SV Rating Plate

1	Goulds Water Technology Catalog Number
2	Capacity Range
3	TDH Range
4	Rated Speed
5	Rated Horsepower
6	Maximum Operating Pressure
7	Maximum Operating Temperature (°F)
8	Pump Efficiency Index
9	Basic Model Number
10	Impeller Diameter
11	Pump Serial Number

e-SV Pump Coverage Curve

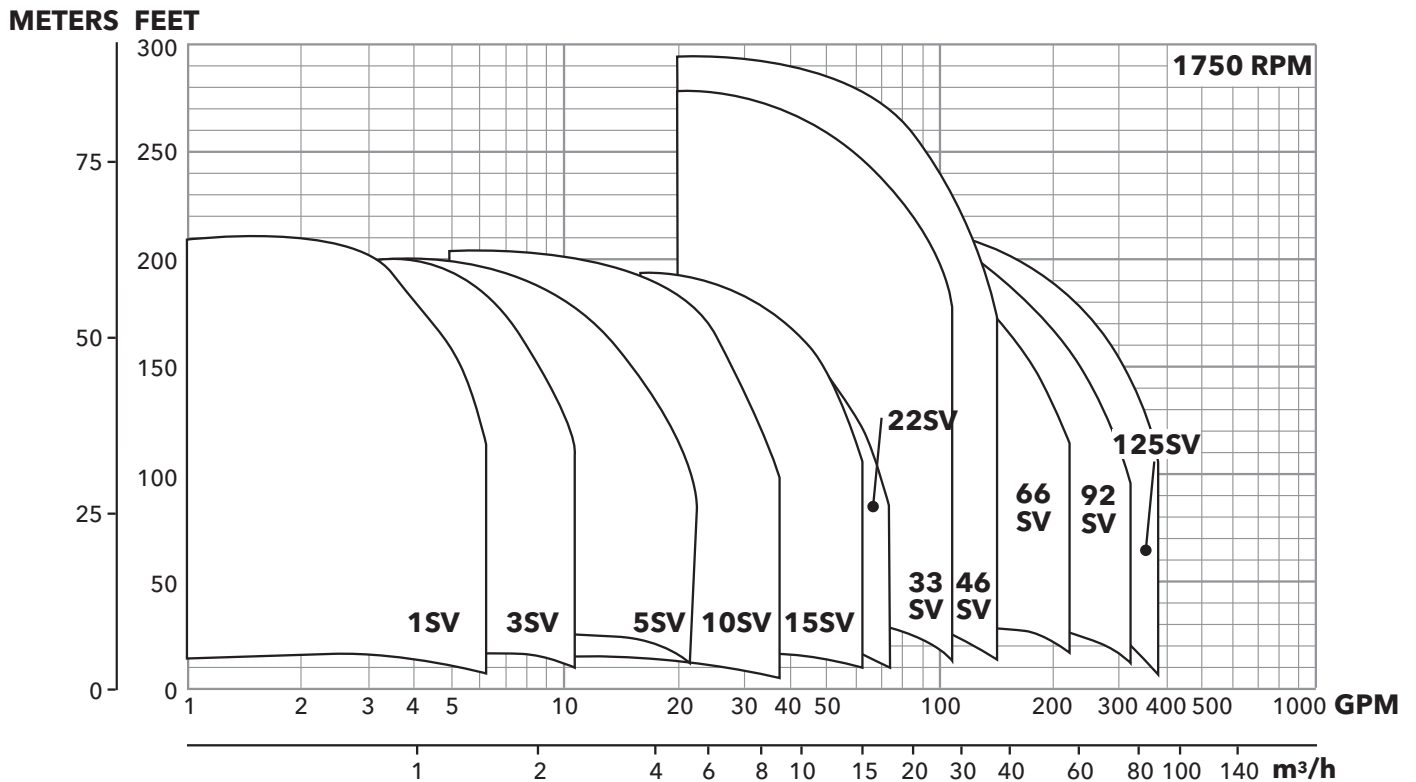
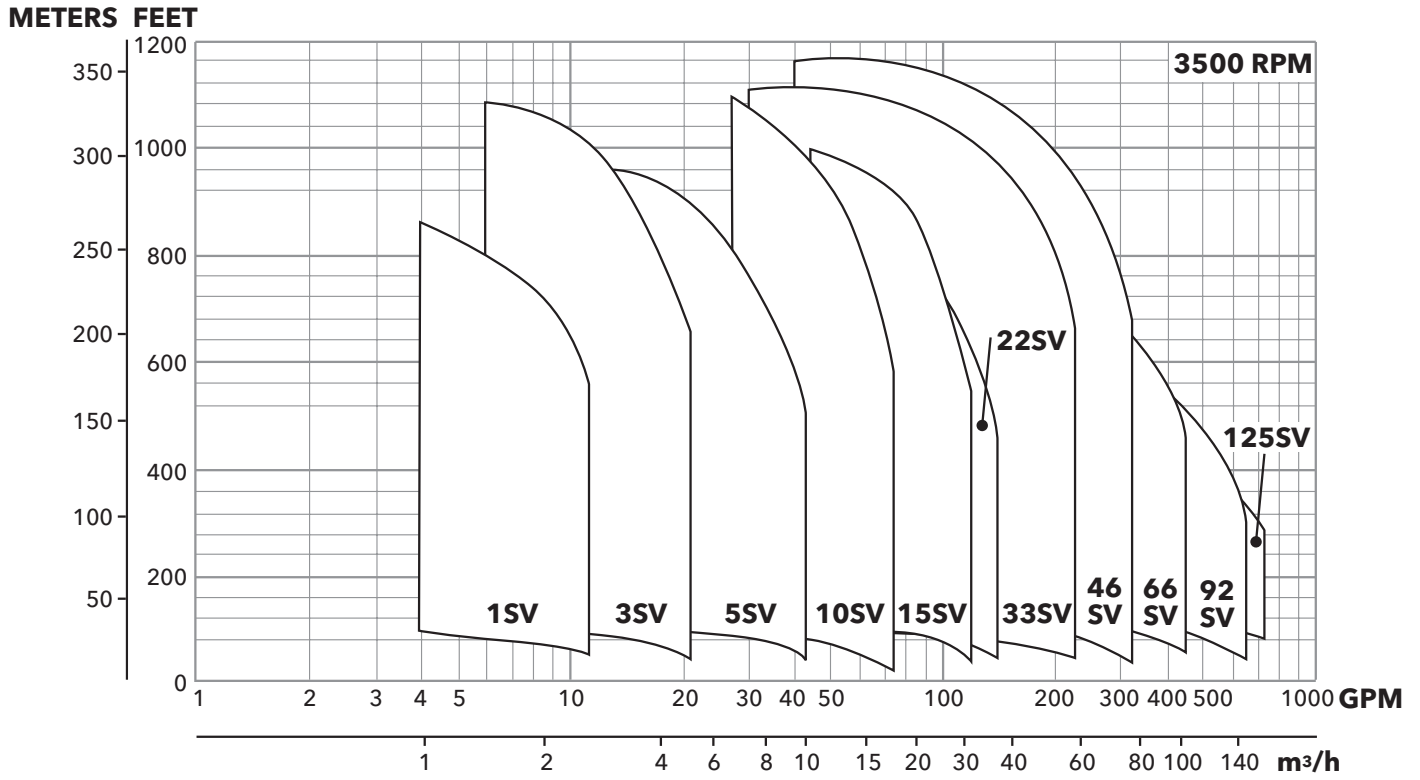

e-SV Multistage Pump General Market Specifications

INDUSTRIAL, COMMERCIAL BUILDING SERVICES, GENERAL MANUFACTURING, AGRICULTURE AND WATER UTILITIES

Applications

- Handling of water, free of suspended solids, in the municipal, industrial and agricultural markets
- Pressure boosting and water supply systems
- Boiler feed
- Fire fighting jockey pumps
- Irrigation systems
- Wash systems
- Reverse osmosis
- Handling of moderately aggressive liquids, demineralized water, water and glycol, etc.
- Circulation of hot and cold water for heating, cooling and conditioning systems

Specifications

PUMP

The e-SV pump is a non-self priming vertical multistage pump coupled to a standard motor. The liquid end, located between the upper cover and the pump casing, is held in place by tie rods. The pump casing is available with different configurations and connection types.

- Delivery: up to 725 gpm
- Head: up to 1200 feet
- Temperature of pumped liquid:
 - 20°F to 250°F (-30°C to 120°C) standard version
- Optional temperature range up to 300°F (149°C) high temperature version (sizes 1-22SV)
- Maximum operating pressure
 - 1-22SV with oval flanges: 230 psi (16 bar)
 - 1-22SV with round flanges or Victaulic: 362 or 575 psi (25 or 40 bar)
 - 33SV, 46SV: 362 or 580 psi (25 or 40 bar)*
 - 66SV, 92SV: 362 or 580 psi (25 or 40 bar)*
 - 125SV: 362 or 580 psi (25 or 40 bar)
- Direction of rotation: clockwise looking at the pump from the top down (marked with an arrow on the adapter and on the coupling).

MOTOR

- Standard NEMA premium TC frame motors in open drip proof or totally enclosed fan cooled.
- 3500 rpm nominal
- Standard voltage:
 - Single-phase version: 115-208/230 V, 60 Hz up to 3 hp or 208-230 V for 5 hp
 - Three-phase version, 2 pole: 208-230/460 V, 60 Hz up to 75 hp

* Based on pump staging

e-SV Pump Characteristics

1SV, 3SV, 5SV, 10SV, 15SV, 22SV Series

- Vertical multistage centrifugal pump. All metal parts in contact with the pumped liquid are made of stainless steel.
- The following versions are available:
 - F - ANSI flanges, in-line delivery and suction ports, AISI 304
 - T - Oval flanges (NPT), in-line delivery and suction ports, AISI 304
 - R - ANSI flanges, delivery port above the suction port, with four adjustable positions, AISI 304
 - N - ANSI flanges, in-line delivery and suction ports, AISI 316
 - P - Victaulic couplings, in-line delivery and suction ports, AISI 316
 - G - ANSI flange, in-line delivery and suction ports, Class 35/40B cast iron.
 - C - ISO clamp, AISI 316
- Innovative axial load compensation system on pumps with higher head. This ensures reduced axial thrusts and enables the use of standard NEMA TC motors.
- Seal housing chamber designed to prevent the accumulation of air in the critical area next to the mechanical seal
- Mechanical seal according to EN 12756 (ex DIN 24960) and ISO 3069
- Versions with ANSI flanges that can be coupled to ANSI raised face counter-flanges
- Threaded oval counter-flanges made of stainless steel are standard supply for the T versions
- Easy maintenance. No special tools required for assembly or disassembly
- Standard version for temperatures ranging from: -20°F to 250°F (30°C to 120°C)

33SV, 46SV, 66SV, 92SV, 125SV Series

- Vertical multistage centrifugal pump with impellers, diffusers and outer sleeve made entirely of stainless steel, and with pump casing and motor adapter made of cast iron in the standard version
- Rotating components made entirely of AISI 316 stainless steel
- High heads and capacities five sizes: 33SV, 46SV, 66SV, 92SV, 125SV
- Redesigned liquid end provides improved efficiency and energy savings
- Innovative axial load compensation system on pumps with higher head. This ensures reduced axial thrusts and enables the use of standard NEMA TC motors.
- Balanced mechanical seal according to EN 12756 (ex DIN 24960) and ISO 3069, which can be replaced without removing the motor from the pump
- Seal housing chamber designed to prevent the accumulation of air in the critical area next to the mechanical seal
- Standard version for temperature ranging from: -20°F to 250°F (-30°C to 120°C)
- Pump body fitted with taps for installing pressure gauges on both suction and delivery flanges
- In-line ports with ANSI flanges that can be coupled to counter-flanges, in compliance with ANSI raised face.
- Mechanical sturdiness and easy maintenance. No special tools required for assembly or disassembly.

Optional Features

- Horizontal version
- Special voltages, 50 Hz frequency
- Special materials for the mechanical seal, gaskets and elastomers
- Tropicalized motors
- Explosion proof and wash down motors
- 1750 rpm, 4 pole motors
- Passivation

Commercial Water

General Characteristics - 2-pole

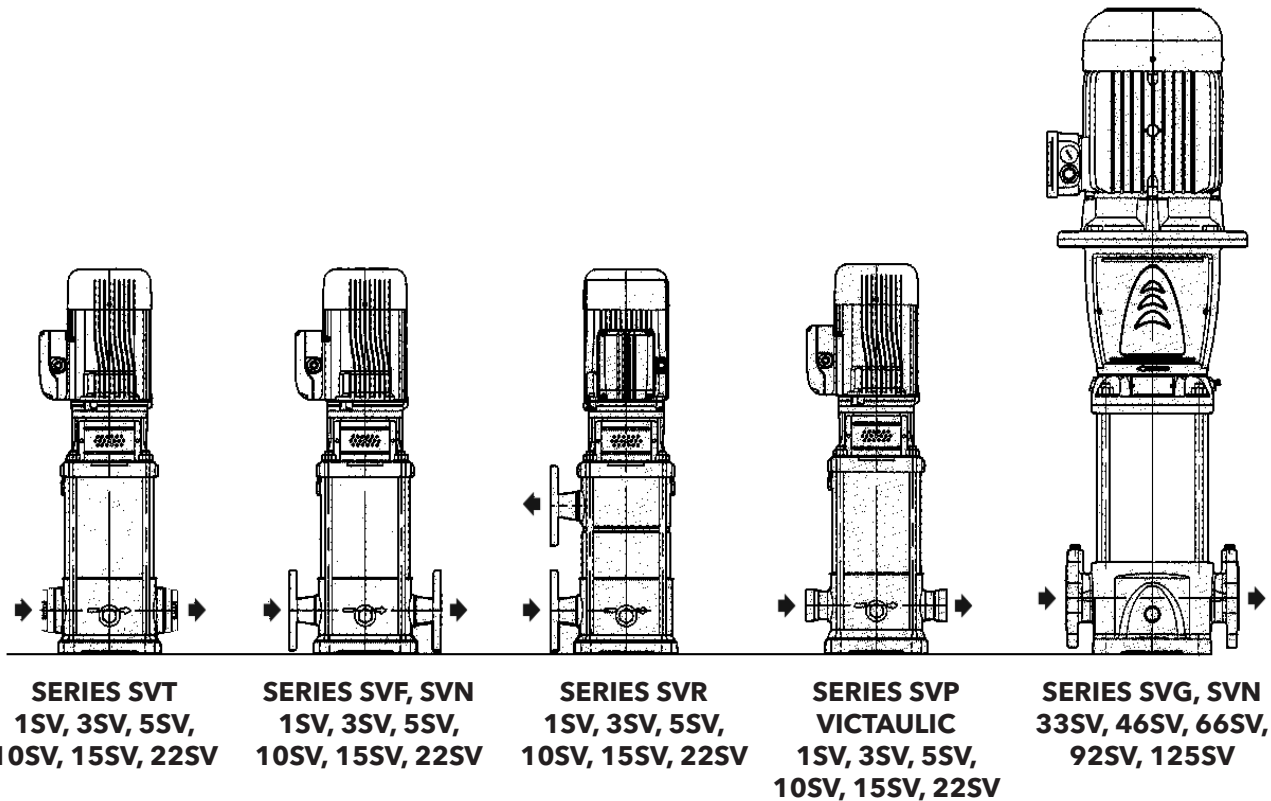

e-SV Product Range	1SV	3SV	5SV	10SV	15SV	22SV	33SV	46SV	66SV	92SV	125SV
Nominal Flow (GPM)	9	15	30	50	80	110	150	220	350	450	600
Flow Range(GPM)	2-12	3-22	7-45	9-75	18-125	21-150	30-195	45-285	70-420	90-580	120-700
Max. Head (Ft)	860	1085	975	1150	1060	880	1125	1210	850	715	570
Max. Working Pressure (PSIG)	362/580										
Temperature Range (°F)	Standard -20°F - 250°F (-30°C - 121°C)										
High Temp Option	up to 300°F (150°C)							-			
Motor Power [HP]	½ - 5 HP	½ - 7½	¾ - 10	¾ - 20	2 - 25	3 - 30	3 - 60	7½ - 75	10 - 75	15 - 75	20 - 75
Max Pump Efficiency	51%	60%	70%	70%	70%	71%	76%	78%	78%	80%	79%
Materials of Construction											
SVT	304 SS						-				
SVF	304 SS						-				
SVN	316L SS						Cast Stainless Steel / 316L SS				
SVR	304 SS						-				
SVP	316L SS						-				
SVC	316L SS						-				
SVG	ASTM Class 35/40B Cast Iron / 304 SS										
Connection Sizes											
SVT - Oval NPT	1¼"	1¼"	1¼"	2"	2"	2"	-				
SVF - Round ANSI Size/Class	1¼" 300#	1¼" 300#	1¼" 300#	2" 300#	2" 300#	2" 300#	-				
SVN - Round ANSI Size/Class	1¼" 300#	1¼" 300#	1¼" 300#	2" 300#	2" 300#	2" 300#	2½" 150/300#	3" 150/300#	4" 150/300#	4" 150/300#	5" 150/300#
SVR - Top/Bottom Round ANSI Size/Class	1¼" 300#	1¼" 300#	1¼" 300#	2" 300#	2" 300#	2" 300#	-				
SVP - Victaulic	1¼"	1¼"	1¼"	2"	2"	2"	-				
SVC - Clamp	1½"	1½"	1½"	2"	2"	2"	-				
SVG - Cast Iron Size/Class	1¼" 250#	1¼" 250#	1¼" 250#	2" 250#	2" 250#	2" 250#	2½" 125/250#	3" 125/250#	4" 125/250#	4" 125/250#	5" 125/250#

Commercial Water

Typical Applications of e-SV Series Multistage Pumps

Water Supply and Pressure Boosting

- Pressure boosting in buildings, hotels, residential complexes
- Pressure booster stations, supply of water networks
- Booster packages

Water Treatment

- Ultra filtration systems
- Reverse osmosis systems
- Water softeners and de-mineralization
- Distillation systems
- Filtration

Light Industry

- Washing and cleaning plants (washing and degreasing of mechanical parts, car and truck wash tunnels, washing of electronic industry circuits)
- Commercial washers
- Fire fighting system pumps

Irrigation and Agriculture

- Greenhouses
- Humidifiers
- Sprinkler irrigation

Heating, Ventilation and Air Conditioning (HVAC)

- Cooling towers and systems
- Temperature control systems
- Refrigerators
- Induction heating
- Heat exchangers
- Boilers
- Water recirculation and heating

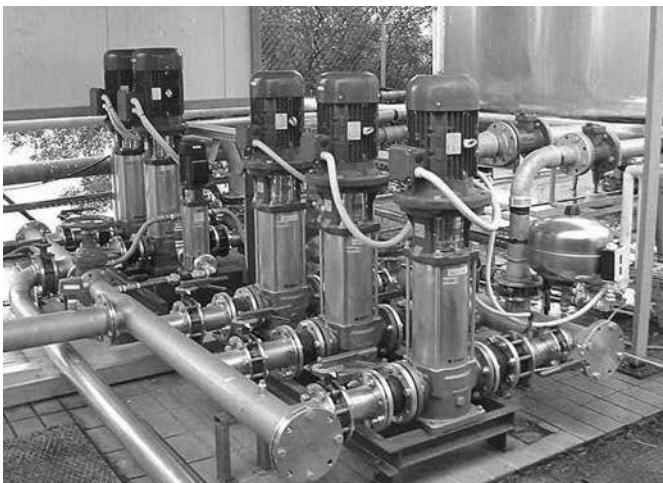

Commercial Water

e-SV Multistage Pumps

Product Code for 1 - 22SV Liquid End Only

Each e-SV pump is identified by a product code on the pump label. Each digit in the code is described below. The product code is also the catalog number for the pump.

Note: Not all combinations are possible.

Example Product Code

22 SV 0 2 F E 3 0

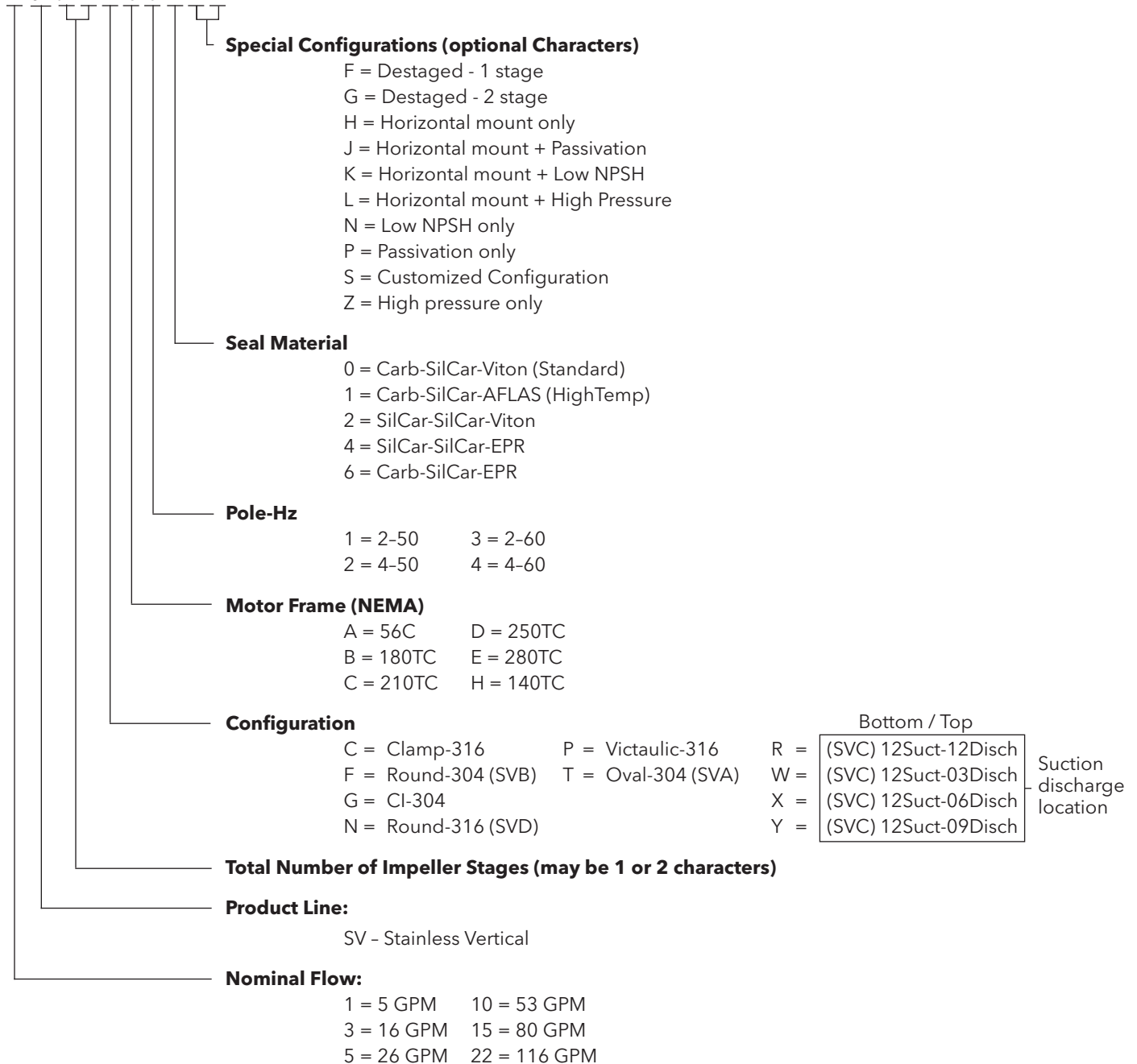

e-SV Multistage Pumps

Product Code for 33 - 125SV Liquid End Only

Each e-SV pump is identified by a product code on the pump label. Each digit in the code is described below. The product code is also the catalog number for the pump.

Note: Not all combinations are possible.

Example Product Code

125 SV 8 1 2 B F E 2 0

Special Configurations (optional Characters)

- H = Horizontal mount only
- J = Horizontal mount + Passivation
- K = Horizontal mount + Low NPSH (33, 46 and 66 only)
- L = Horizontal mount + High Pressure
- N = Low NPSH only (33, 46 and 66 only)
- S = Customized Configuration
- Z = High pressure (250/300# pump body)

Seal Material

- 0 = Carb-SilCar-Viton
- 2 = SilCar-SilCar-Viton
- 4 = SilCar-SilCar-EPR
- 6 = Carb-SilCar-EPR
- 7 = Carb-SilCar-Viton (Cart)
- 8 = SilCar-SilCar-EPR (Cart)

Pole-Hz

- 1 = 2-50 3 = 2-60
- 2 = 4-50 4 = 4-60

Motor Frame (NEMA)

- B = 180TC E = 280TC
- C = 210TC F = 320TSC
- D = 250TC G = 360TSC

Configuration

- G = Round-CI-304
- N = Round-316

125SV ONLY

- Reduced Trim Diameter** A = 141 mm B = 136 mm C = 145 mm (full dia.)
Blank if 33-92SV

Number of Reduced Trim Impellers

Total Number of Impellers/Stages

Product Line: SV - Stainless Vertical

Nominal Flow:

- 33 = 175 GPM
- 46 = 240 GPM
- 66 = 350 GPM
- 92 = 485 GPM
- 125 = 660 GPM

Commercial Water

e-SV Multistage Pumps

Product Code for 1 - 22SV Pump & Motor Combination

Each e-SV pump is identified by a product code on the pump label. Each digit in the code is described below. The product code is also the catalog number for the pump.

Note: Not all combinations are possible.

Example Product Code

22 SV 2 2 F A 2 F 5 1 A H

Special Configurations (1 or 2 Characters)

- F = Destaged - 1 stage
- G = Destaged - 2 stage
- H = Horizontal mount only
- J = Horizontal mount + Passivation
- K = Horizontal mount + Low NPSH
- L = Horizontal mount + High Pressure
- N = Low NPSH only
- P = Passivation only
- S = Customized Configuration
- Z = High Press (250/300# pump body)

Seal Material

- 0 = Carb-SilCar-Viton
- 1 = Carb-SilCar-AFLAS (HighTemp)
- 2 = SilCar-SilCar-Viton
- 4 = SilCar-SilCar-EPR
- 6 = Carb-SilCar-EPR

Motor Enclosure

- 1 = ODP
- 2 = TEFC
- 3 = X-Proof
- 4 = WD - Tropical
- 5 = Prem-ODP
- 6 = Prem-TEFC
- 7 = Prem-XP
- 8 = Prem-WD
- 9 = Marine
- A = Chem
- B = Prem-Chem
- C = Class 1 Div 2

Voltage

- A = 115/230
- B = 230
- C = 230/460
- D = 460
- E = 575
- F = 208-230/460
- G = 200
- H = 190/380
- J = 115/208-230
- K = 208
- L = 208-230
- M = 190-380/415
- N = 380
- P = 110/220
- R = 220
- S = 415
- T = 220/380 WYE
- U = 380-660 WYE
- V = 208-230/460 WYE
- W = 220/380/440

Pole-Hz-Phase

- 1 = 2-50-1
- 2 = 2-50-3
- 3 = 2-60-1
- 4 = 2-60-3
- 5 = 4-50-1
- 6 = 4-50-3
- 7 = 4-60-1
- 8 = 4-60-3

HP Rating

- A = 0.50
- B = 0.75
- C = 1.00
- D = 1.50
- E = 2
- F = 3
- G = 5
- H = 7.5
- J = 10
- K = 15
- L = 20
- M = 25
- N = 30
- P = 40
- R = 50
- S = 60
- T = 75
- U = 100

Configuration OPTION

- C = Clamp-316
- F = Round-304 (SVB)
- G = CI-304
- N = Round-316 (SVD)
- P = Victaulic-316
- T = Oval-304 (SVA)
- R = (SVC) 12Suct-12Disch
- W = (SVC) 12Suct-03Disch
- X = (SVC) 12Suct-06Disch
- Y = (SVC) 12Suct-09Disch

Bottom / Top

Suction
discharge
location

Total Number of Impeller Stages (may be 1 or 2 characters)

Product Line:

SV - Stainless Vertical

Nominal Flow:

- 1 = 5 GPM
- 3 = 16 GPM
- 5 = 26 GPM
- 10 = 53 GPM
- 15 = 80 GPM
- 22 = 116 GPM

e-SV Multistage Pumps

Product Code for 33 - 125SV Pump & Motor Combination

Each e-SV pump is identified by a product code on the pump label. Each digit in the code is described below. The product code is also the catalog number for the pump.

Note: Not all combinations are possible.

Example Product Code

125SV 8 2 A G K 3 F 2 0

Special Configurations (1 or 2 Characters)

- H = Horizontal mount only
- J = Horizontal mount + Passivation
- K = Horizontal mount + Low NPSH
- L = Horizontal mount + High Pressure
- N = Low NPSH only (33, 46 and 66 only)
- P = Passivation only
- S = Customized Configuration
- Z = High Press (250/300# pump body/Casing)

Seal Material

- 0 = Carb-SilCar-Viton
- 2 = SilCar-SilCar-Viton
- 4 = SilCar-SilCar-EPR
- 6 = Carb-SilCar-EPR
- 7 = Carb-SilCar-Viton (Cart)
- 8 = SilCar-SilCar-EPR (Cart)

Motor Enclosure

- 1 = ODP
- 2 = TEFC
- 3 = X-Proof
- 4 = WD - Tropical
- 5 = Prem-ODP
- 6 = Prem-TEFC
- 7 = Prem-XP
- 8 = Prem-WD
- 9 = Marine
- A = Chem
- B = Prem-Chem
- C = Class 1 Div 2

Voltage

- A = 115/230
- B = 230
- C = 230/460
- D = 460
- E = 575
- F = 208-230/460
- G = 200
- H = 190/380
- J = 115/208-230
- K = 208
- L = 208-230
- M = 190-380/415
- N = 380
- P = 110/220
- R = 220
- S = 415
- T = 220/380 WYE
- U = 380-660 WYE
- V = 208-230/460 WYE

Pole-Hz-Phase

- 1 = 2-50-1
- 2 = 2-50-3
- 3 = 2-60-1
- 4 = 2-60-3
- 5 = 4-50-1
- 6 = 4-50-3
- 7 = 4-60-1
- 8 = 4-60-3

HP Rating

- F = 3
- G = 5
- H = 7.5
- J = 10
- K = 15
- L = 20
- M = 25
- N = 30
- P = 40
- R = 50
- S = 60
- T = 75
- U = 100

Configuration

- G = Round-CI-304
- N = Round-316

125SV ONLY

- Reduced Trim Diameter**
- A = 141 mm
- B = 136 mm
- C = 145 mm (full dia.)
- Blank if 33-92SV**

Number of Reduced Trin Impeller

Total Number of Impeller Stages (may be 1 or 2 characters)

Product Line:

- SV - Stainless Vertical

Nominal Flow:

- 33 = 175 GPM
- 46 = 240 GPM
- 66 = 350 GPM
- 92 = 485 GPM
- 125 = 660 GPM

Base Models: 1-22SV – Major Components

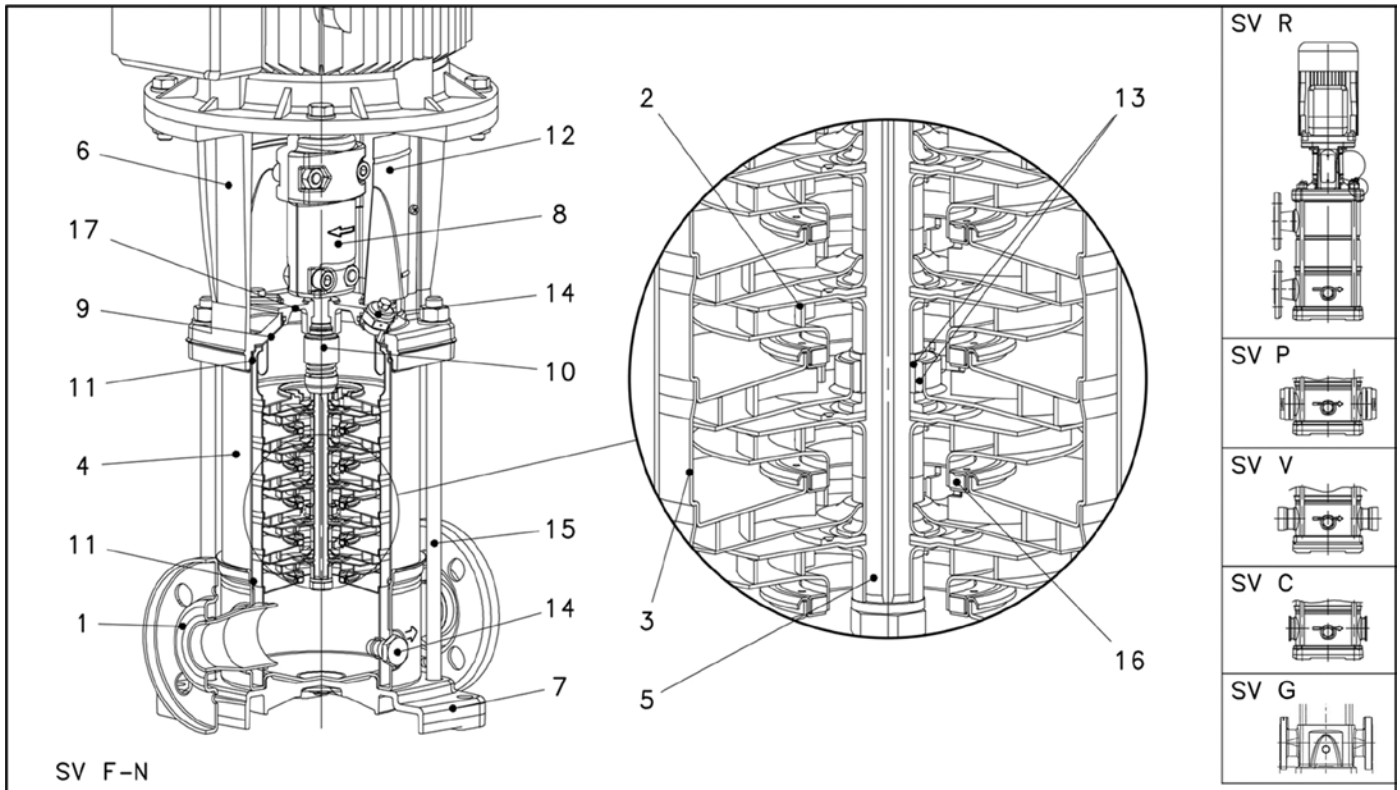

Base Models: 1-22SV – Major Components

F, G, P, R VERSIONS

Ref. No.	Name	Material	Reference Standards	
			USA	Europe
1	Pump Body	Stainless Steel (F, P, R)	AISI 304	EN 10088-1-X5-CrNi18-10 (1.4301)
		Cast Iron (G)	ASTM Class 35/40B	EN 1561 GJL 250 (JL1040)
2	Impeller	Stainless Steel	AISI 304	EN 10088-1-X5-CrNi18-10 (1.4301)
3	Diffuser	Stainless Steel	AISI 304	EN 10088-1-X5-CrNi18-10 (1.4301)
4	Casing	Stainless Steel	AISI 316L	EN 10088-1-X2-CrNiMo17-12-2 (1.4404)
5	Shaft	Stainless Steel	AISI 316	EN 10088-1-X2-CrNiMo17-12-2 (1.4401)
6	Adapter	Cast Iron	ASTM Class 35/40B	EN 1561-GJL-250 (JL1040)
7	Base	Aluminum (F, P, R)	A384.0-F	EN 1706-AC-AISI11Cu2(Fe) (AC46100)
		N/A (G)	N/A	N/A
8	Coupling	Aluminum	A384.0-F	EN 1706-AC-AISI11Cu2(Fe) (AC46100)
9	Seal Plate	Stainless Steel	AISI 316L	EN 10088-1-X2-CrNi17-12-2 (1.4404)
10	Mechanical Seal	Silicon Carbide / Carbon / Viton (opt. EPDM)		
11	Elastomers	Viton (opt. EPDM)		
12	Coupling Guard	Stainless Steel	AISI 304	EN 10088-1-X5-CrNi18-10 (1.4301)
13	Shaft Sleeve and Bushing	Tungsten Carbide		
14	Fill/Drain Plugs	Stainless Steel	AISI 316	EN 10088-1-X2-CrNiMo17-12-2 (1.4401)
15	Tie Rods	Carbon Steel / Zinc Plated	A29 Gr. 1045	EN 10277
16	Wear Ring	PPS		
17	Seal Gland	Stainless Steel	AISI 316	EN 10088-1-X2-CrNiMo17-12-2 (1.4401)

N, P, C VERSIONS

Ref. No.	Name	Material	Reference Standards	
			USA	Europe
1	Pump Body	Stainless Steel	AISI 316L	EN 10088-1-X2-CrNiMo17-12-2 (1.4404)
2	Impeller	Stainless Steel	AISI 316L	EN 10088-1-X2-CrNiMo17-12-2 (1.4404)
3	Diffuser	Stainless Steel	AISI 316L	EN 10088-1-X2-CrNiMo17-12-2 (1.4404)
4	Casing	Stainless Steel	AISI 316L	EN 10088-1-X2-CrNiMo17-12-2 (1.4404)
5	Shaft	Stainless Steel	AISI 316	EN 10088-1-X2-CrNiMo17-12-2 (1.4401)
6	Adapter	Cast Iron	ASTM Class 35/40B	EN 1561-GJL-250 (JL1040)
7	Base	Aluminum	A384.0-F	EN 1706-AC-AISI11Cu2(Fe) (AC46100)
8	Coupling	Aluminum	A384.0-F	EN 1706-AC-AISI11Cu2(Fe) (AC46100)
9	Seal Plate	Stainless Steel	AISI 316L	EN 10088-1-X2-CrNi17-12-2 (1.4404)
10	Mechanical Seal	Silicon Carbide / Carbon / Viton (opt. EPDM)		
11	Elastomers	Viton (opt. EPDM)		
12	Coupling Guard	Stainless Steel	AISI 304	EN 10088-1-X5-CrNi18-10 (1.4301)
13	Shaft Sleeve and Bushing	Tungsten Carbide		
14	Fill/Drain Plugs	Stainless Steel	AISI 316	EN 10088-1-X2-CrNiMo17-12-2 (1.4401)
15	Tie Rods	Carbon Steel / Zinc Plated	A29 Gr. 1045	EN 10277
16	Wear Ring	PPS		
17	Seal Gland	Stainless Steel	AISI 316	EN 10088-1-X2-CrNiMo17-12-2 (1.4401)

Base Model: 33SV, 46SV, 66SV and 92SV – Major Components

SV G-N

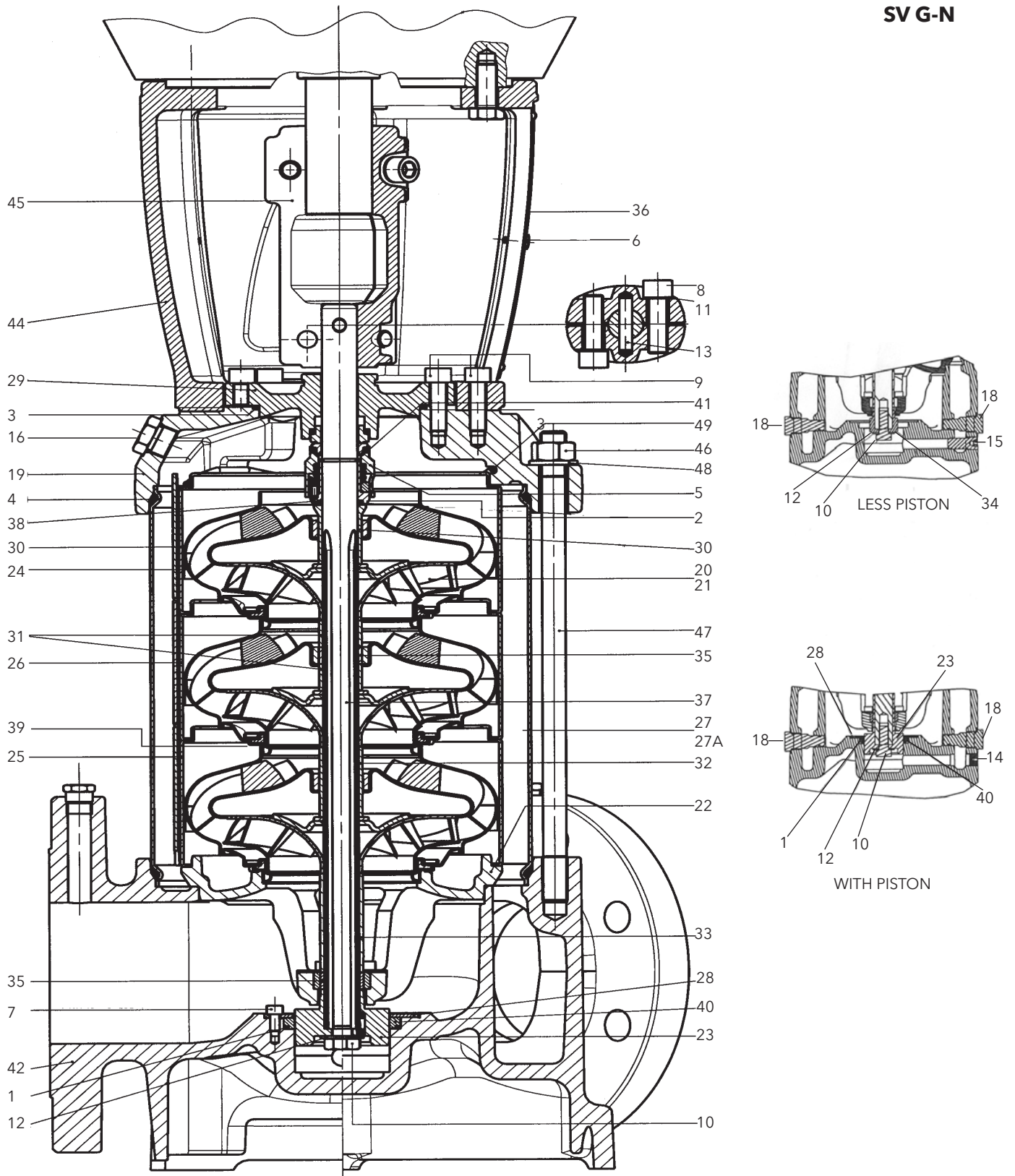

Base Model: 33SV, 46SV, 66SV and 92SV – Major Components

No.	Description	SVG (33 - 92SV)			SVN (33 - 92SV)		
		Material	ASTM	DIN	Material	ASTM	DIN
1	O-Ring, Piston Seal	Viton (std) EPDM (opt)			Viton (std) EPDM (opt)		
2	O-Ring, Mechanical Seal Sleeve	Viton (std) EPDM (opt)			Viton (std) EPDM (opt)		
3	O-Ring, Seal housing	Viton (std) EPDM (opt)			Viton (std) EPDM (opt)		
4	O-Ring, Sleeve	Viton (std) EPDM (opt)			Viton (std) EPDM (opt)		
5	Mechanical Seal	See Seal Materials Chart for Complete Details			See Seal Materials Chart for Complete Details		
5A	Cartridge Seal (not shown)						
6	Screw, Guard	Stainless Steel	A193-304	1.4301	Stainless Steel	A193-304	1.4301
7	Screw, Piston Holding Disc	Stainless Steel	A193-316	1.4401	Stainless Steel	A193-316	1.4401
8	Screw, Coupling	Zinc Plated Steel	B363		Zinc Plated Steel	B633	
9	Screw, MA and Seal Housing	Zinc Plated Steel	B633		Zinc Plated Steel	B633	
10	Screw, Impeller	Stainless Steel	A193-316	1.4401	Stainless Steel	A193-316	1.4401
11	Washer, Coupling	Carbon Steel	A108		Carbon Steel	A108	
12	Washer, Impeller	Stainless Steel	A193-316	1.4401	Stainless Steel	A193-316	1.4401
13	Pin, Coupling	Carbon Steel	A108		Carbon Steel	A108	
14	Plug, with Piston	Stainless Steel	A193-316	1.4401	Stainless Steel	A193-316	1.4401
15	Plug, without Piston	Stainless Steel	A193-316	1.4401	Stainless Steel	A193-316	1.4401
16	Plug, Fill	Stainless Steel/O-Ring	A193-316	1.4401	Stainless Steel/O-Ring	A193-316	1.4401
17	Plug, Vent (not shown)	Stainless Steel/O-Ring	A193-316	1.4401	Stainless Steel/O-Ring	A193-316	1.4401
18	Plug, Drain	Stainless Steel/O-Ring	A193-316	1.4401	Stainless Steel/O-Ring	A193-316	1.4401
19	Pump Head	Cast Iron	A48 Class 35	JL1030	Stainless Steel	316 CF8M	1.4408
20	Impeller, Full Diameter	Stainless Steel	A193-316L	1.4404	Stainless Steel	A193-316L	1.4404
21	Impeller, Reduced Diameter	Stainless Steel	A193-316L	1.4404	Stainless Steel	A193-316L	1.4404
22	Lower Bearing Assembly	SS/Cast Iron	A193-316L/A48 Class 35	1.4404/JL1030	Stainless Steel	A193-316L/316 CF8M	1.4404/1.4408
23	Piston	Duplex SS	A182-F51	1.4462	Duplex SS	A182-F51	1.4462
24	Diffuser, Final	Stainless Steel	A193-316L	1.4404	Stainless Steel	A193-316L	1.4404
25	Diffuser with Carbon Bushing	Stainless Steel	A193-316L	1.4404	Stainless Steel	A193-316L	1.4404
26	Diffuser with Tungsten Bushing	Stainless Steel	A193-316L	1.4404	Stainless Steel	A193-316L	1.4404
27	Outer Sleeve, 25 Bar	Stainless Steel	A193-316L	1.4404	Stainless Steel	A193-316L	1.4404
27A	Outer Sleeve, 40 Bar	Stainless Steel	A193-316L	1.4404	Stainless Steel	A193-316L	1.4404
28	Holding Disc, Piston Seal	Stainless Steel	A193-316L	1.4404	Stainless Steel	A193-316L	1.4404
29	Seal Housing	Cast Iron	A48 Class 35	JL1030	Stainless Steel	316 CF8M	1.4408
30	Spacer, Impeller Final	Stainless Steel	A193-316	1.4401	Stainless Steel	A193-316	1.4401
31	Spacer, Shaft Bushing	Stainless Steel	A193-316	1.4401	Stainless Steel	A193-316	1.4401
32	Spacer, Impeller	Stainless Steel	A193-316	1.4401	Stainless Steel	A193-316	1.4401
33	Spacer, Impeller Lower (66-92SV)	Stainless Steel	A193-316	1.4401	Stainless Steel	A193-316	1.4401
34	Bushing, Non-Piston	Stainless Steel	A193-316	1.4401	Stainless Steel	A193-316	1.4401
35	Tungsten Carbide Bushing	Tungsten Carbide			Tungsten Carbide		
36	Coupling Guard	Stainless Steel	A193-304	1.4301	Stainless Steel	304	1.4301
37	Shaft	Duplex SS	A182-F51	1.4462	Duplex SS	A182-F51	1.4462
38	Mechanical Seal Shaft Sleeve	Stainless Steel	A193-316	1.4401	Stainless Steel	A193-316	1.4401
39	Wear Ring, Impeller	PPS Glass Filled			PPS Glass Filled		
40	Piston Seal	Impregnated Carbon			Impregnated Carbon		
41	Stop Ring, Impeller	Stainless Steel	A193-316	1.4401	Stainless Steel	A193-316	1.4401
42	Pump Body	Cast Iron	A48 Class 35	JL1030	Stainless Steel	316 CF8M	1.4408
43	Motor Adapter Plate (not shown)	Cast Iron	A48 Class 25	JL1030	Cast Iron	A48 Class 25	JL1030
44	Motor Adapter	Cast Iron	A48 Class 25	JL1030	Cast Iron	A48 Class 25	JL1030
45	Coupling, Half	Cast Iron	A48 Class 25	JL1030	Cast Iron	A48 Class 25	JL1030
46	Nut, Tie-Rod	Zinc Plated Steel	B633		Zinc Plated Steel	B633	
47	Tie-Rod	Zinc Plated Steel	B633		Zinc Plated Steel	B633	
48	Washer, Tie-Rod	Zinc Plated Steel	B633		Zinc Plated Steel	B633	
49	Spring, Final Diffuser	Stainless Steel	A193-316	1.4401	Stainless Steel	A193-316	1.4401

Base Models: 125SV – Major Components

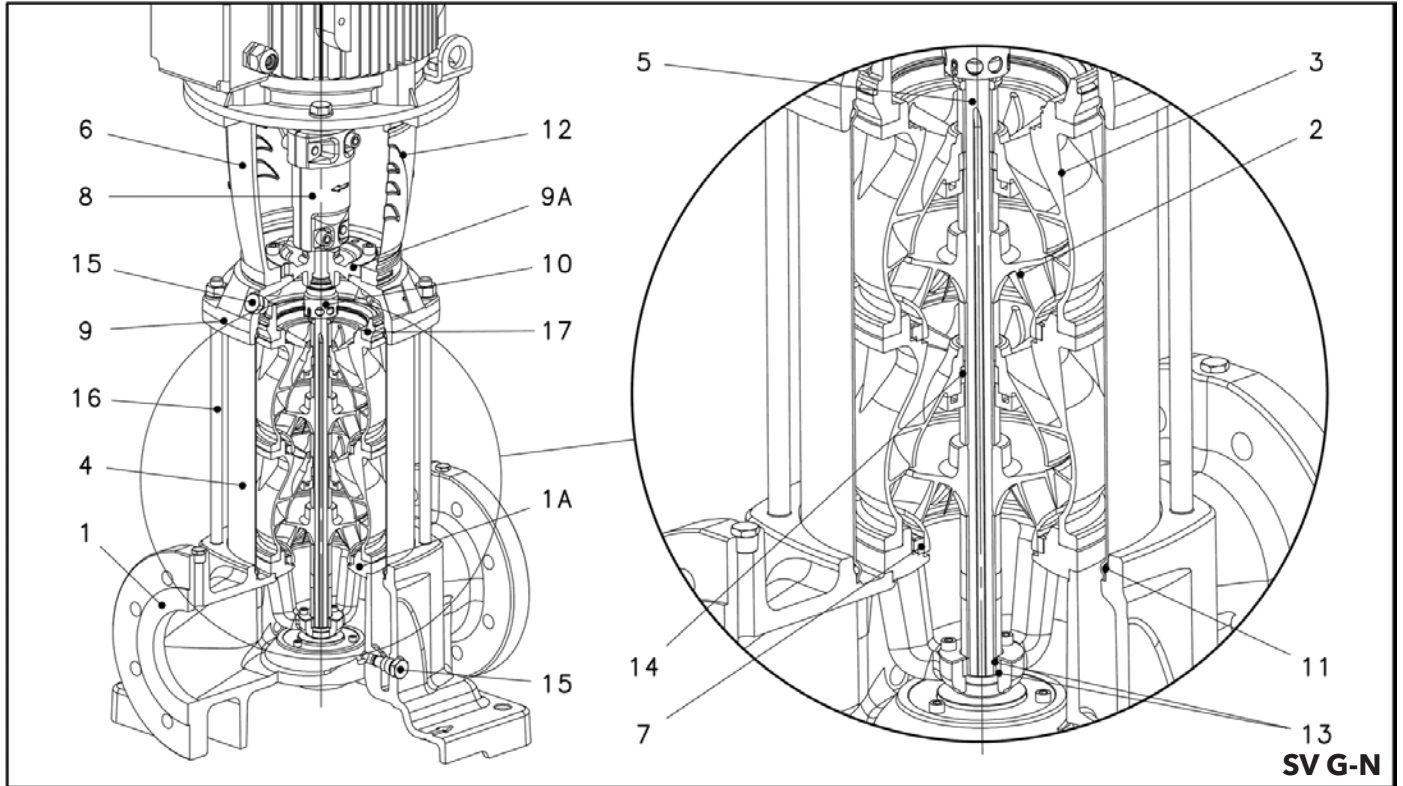

Base Models: 125SV – Major Components

G VERSIONS

Ref. No.	Name	Material	Reference Standards	
			USA	Europe
1	Pump Body	Cast Iron	ASTM Class 35/40B	EN 1561-GJL-250 (JL1040)
2	Impeller	Stainless Steel	AISI 304	EN 10088-1-X5-CrNi18-10 (1.4301)
3	Diffuser	Stainless Steel	AISI 304	EN 10088-1-X5-CrNi18-10 (1.4301)
4	Casing	Stainless Steel	AISI 316L	EN 10088-1-X2-CrNiMo17-12-2 (1.4404)
5	Shaft	Duplex Stainless Steel	UNS S 31803	EN 10088-1-X17-CrNiMoN22-5-3 (1.4507)
6	Adapter (up to 40HP)	Cast Iron	ASTM Class 25	EN 1561-GJL-200 (JL1040)
	Adapter (50HP and higher)		ASTM Class A536	EN 1561-GJL-500-7 (JS1050)
7	Wear Ring	PPS		
8	Coupling (up to 40HP)	Cast Iron	A384.0-F	EN 1706-AC-AISI11Cu2(Fe)(AC46100)
	Coupling (50HP and higher)			
9-9A	Upper Head / Seal Housing	Cast Iron	ASTM Class 35/40B	EN 1561-GJL-250 (JL1040)
10	Mechanical Seal	Silicon Carbide / Carbon / Viton (opt. EPDM)		
11	Elastomers	Viton (opt. EPDM)		
12	Coupling Guard	Stainless Steel	AISI 304	EN 10088-1-X5-CrNi18-10 (1.4301)
13	Shaft Sleeve and Bushing	Tungsten Carbide		
14	Bushing for Diffuser	Carbon		
15	Fill/Drain Plugs	Stainless Steel	AISI 316	EN 10088-1-X2-CrNiMo17-12-2 (1.4401)
16	Tie Rods	Carbon Steel / Zinc Plated	A29 Gr. 1045	EN 10277
17	Adapter Ring	Stainless Steel	AISI 304	EN 10088-1-X5-CrNi18-10 (1.4301)

N VERSIONS

Ref. No.	Name	Material	Reference Standards	
			USA	Europe
1	Pump Body	Stainless Steel	AISI 316	EN 10088-1-X2-CrNiMo17-12-2 (1.4401)
2	Impeller	Stainless Steel	AISI 316	EN 10088-1-X2-CrNiMo17-12-2 (1.4401)
3	Diffuser	Stainless Steel	AISI 316	EN 10088-1-X2-CrNiMo17-12-2 (1.4401)
4	Casing	Stainless Steel	AISI 316L	EN 10088-1-X2-CrNiMo17-12-2 (1.4404)
5	Shaft	Duplex Stainless Steel	UNS S 31803	EN 10088-1-X17-CrNiMoN22-5-3 (1.4507)
6	Adapter (up to 40HP)	Cast Iron	ASTM Class 25	EN 1561-GJL-200 (JL1040)
	Adapter (50HP and higher)		ASTM Class A536	EN 1561-GJL-500-7 (JS1050)
7	Wear Ring	PPS		
8	Coupling (up to 40HP)	Cast Iron	A384.0-F	EN 1706-AC-AISI11Cu2(Fe)(AC46100)
	Coupling (50HP and higher)			
9-9A	Upper Head / Seal Housing	Stainless Steel	AISI 316	EN 10088-1-X2-CrNiMo17-12-2 (1.4401)
10	Mechanical Seal	Silicon Carbide / Carbon / Viton (opt. EPDM)		
11	Elastomers	Viton (opt. EPDM)		
12	Coupling Guard	Stainless Steel	AISI 304	EN 10088-1-X5-CrNi18-10 (1.4301)
13	Shaft Sleeve and Bushing	Tungsten Carbide		
14	Bushing for Diffuser	Carbon		
15	Fill/Drain Plugs	Stainless Steel	AISI 316	EN 10088-1-X2-CrNiMo17-12-2 (1.4401)
16	Tie Rods	Carbon Steel / Zinc Plated	A29 Gr. 1045	EN 10277
17	Adapter Ring	Stainless Steel	AISI 304	EN 10088-1-X5-CrNi18-10 (1.4301)

Commercial Water

e-SV Mechanical Seals

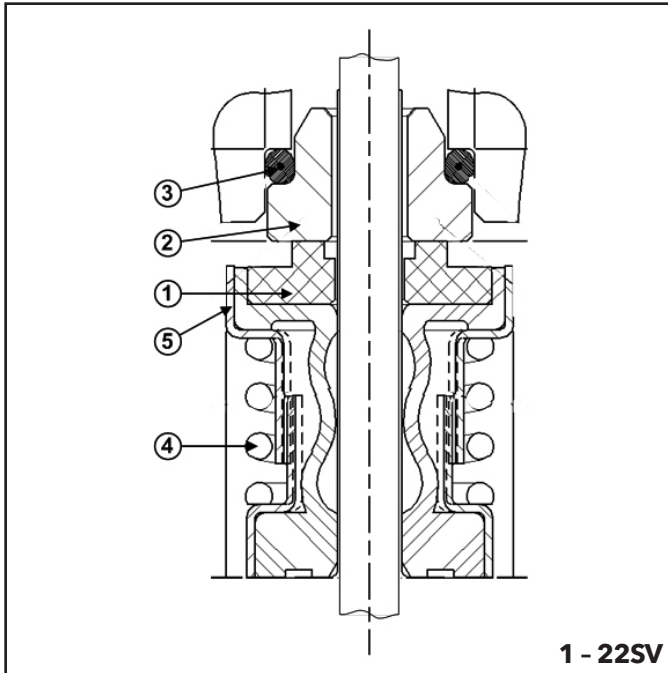

1 - 22SV

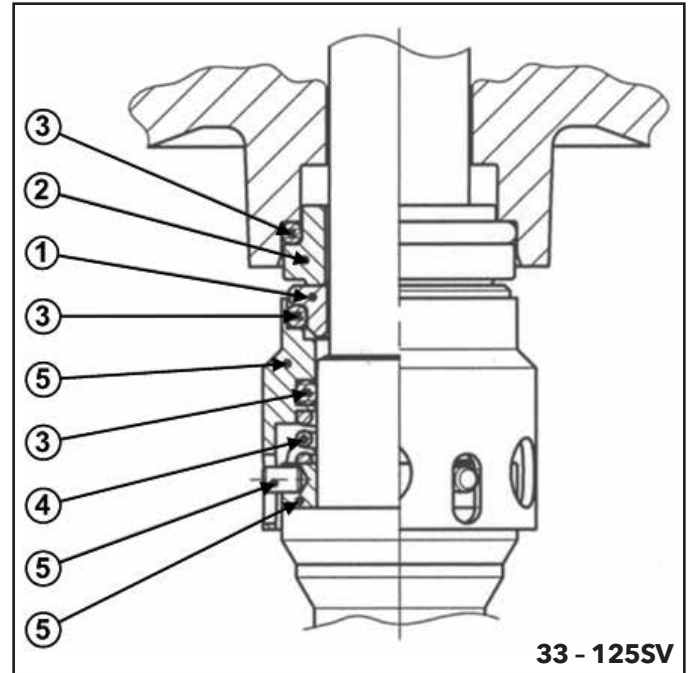

33 - 125SV

Pump	Code	Rotating Face 1	Stationary Face 2	Elastomers 3	Spring 4	Metal Components 5	Elastomer Temp Limits °F (°C)	Seal Temp Limits °F (°C)	Max. Working Pressure	Application
1SV thru 22SV	0	Carbon	Silicon Carbide Graphite Filled	Viton	316SS	316SS	-14 - 392°F (-10 - 200°C)	-22 - 250°F	580 psi (40 bar)	General Service
	2	Silicon Carbide Graphite Filled		EPR			-30 - 300°F (-34 - 150°C)			Severe Duty
	4									Severe Duty Boiler Feed
	6	Carbon		AFLAS			-14 - 392°F (-10 - 200°C)			up to 300°F (149°C)
	1	FDA Grade Carbon						Boiler Feed		
33SV thru 125SV	0	Carbon	Silicon Carbide Graphite Filled	Viton	316SS	316SS	-14 - 392°F (-10 - 200°C)	-22 - 250°F (-30 - 120°C)	580 psi (40 bar)	General Service
	2	Silicon Carbide Graphite Filled		EPR			-22 - 250°F (-30 - 120°C)			Severe Duty
	4									Severe Duty Boiler Feed
	6	Carbon		General Service Boiler Feed						

Pump	Rotating Face 1	Stationary Face 2	Elastomers 3	Spring 4	Sleeve 5	Set Screw 6	Locking Collar
33SV	Silicon Carbide	Carbon	Viton	316SS	316SS	300SS	316SS
46SV		Carbon	Viton				
66SV		Silicon Carbide	EPR				
92SV		Silicon Carbide	EPR				

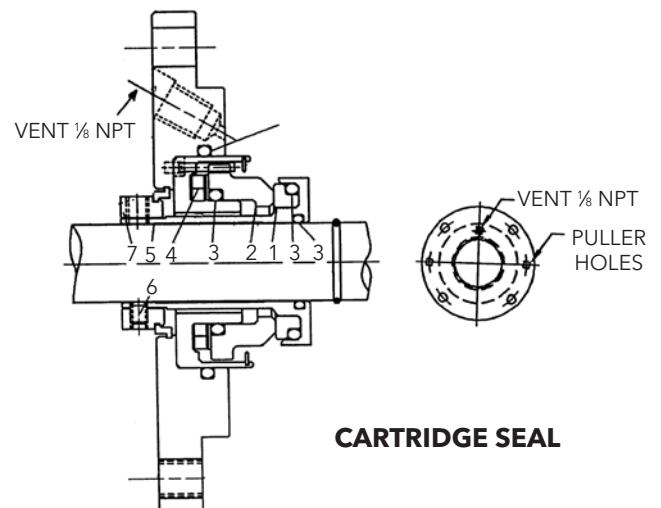

CARTRIDGE SEAL

Maximum Allowable Working Pressure Charts

1SV-22SV

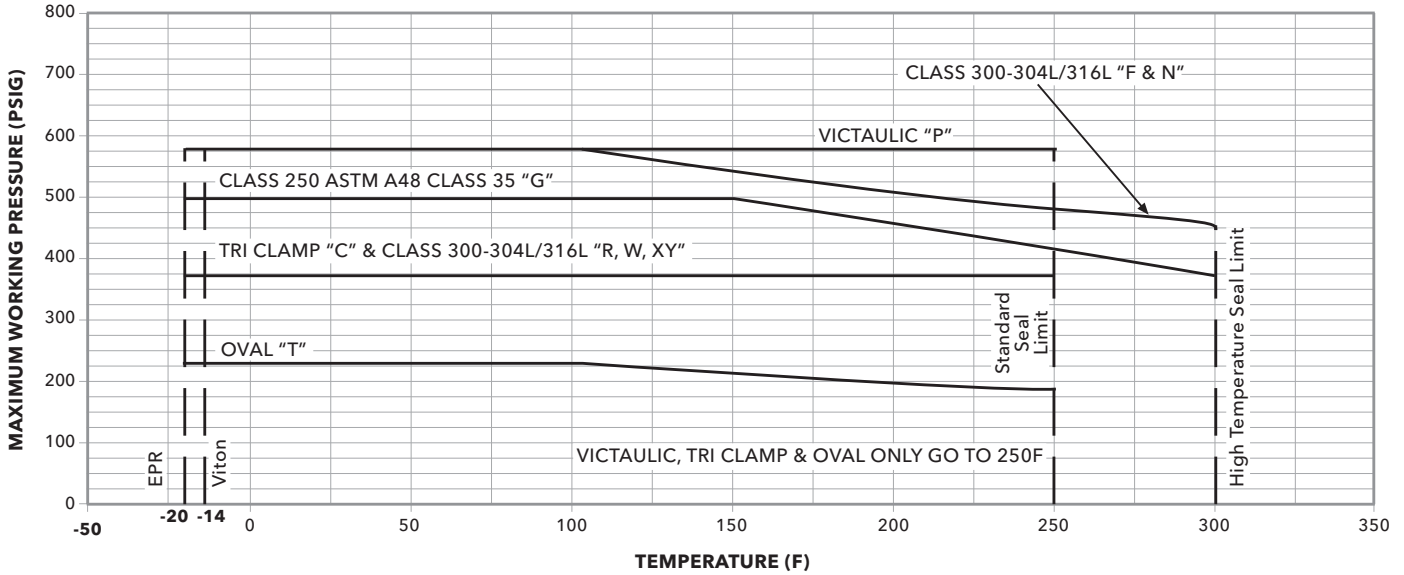

33SV-125SV

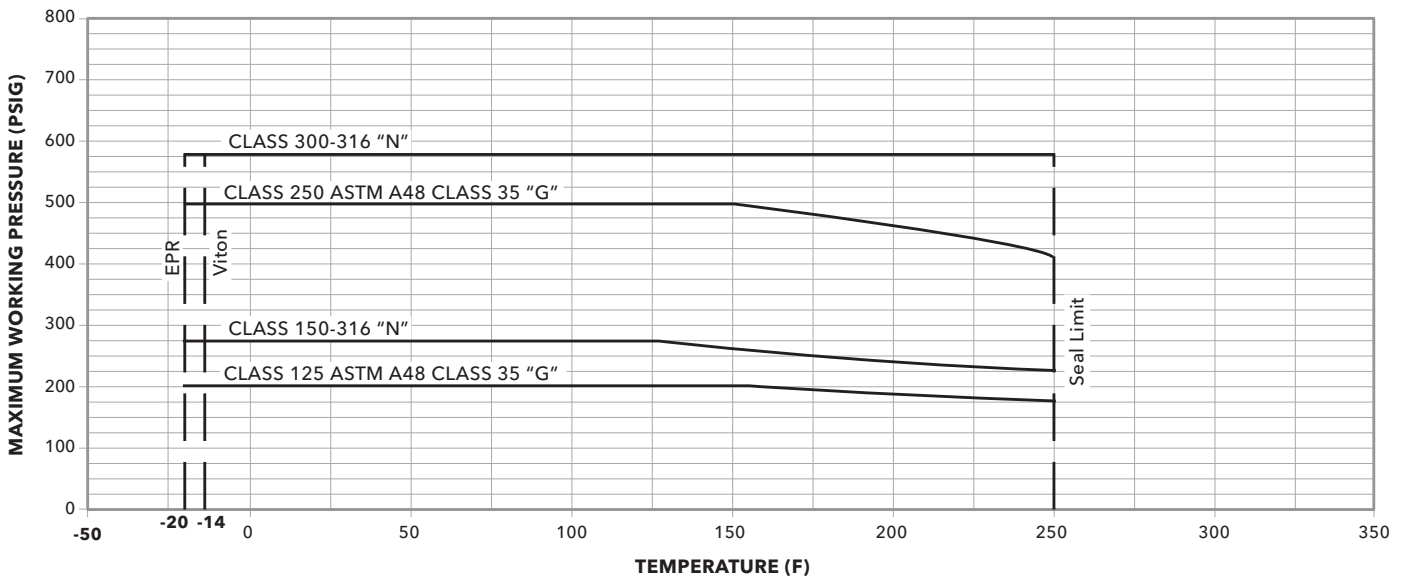

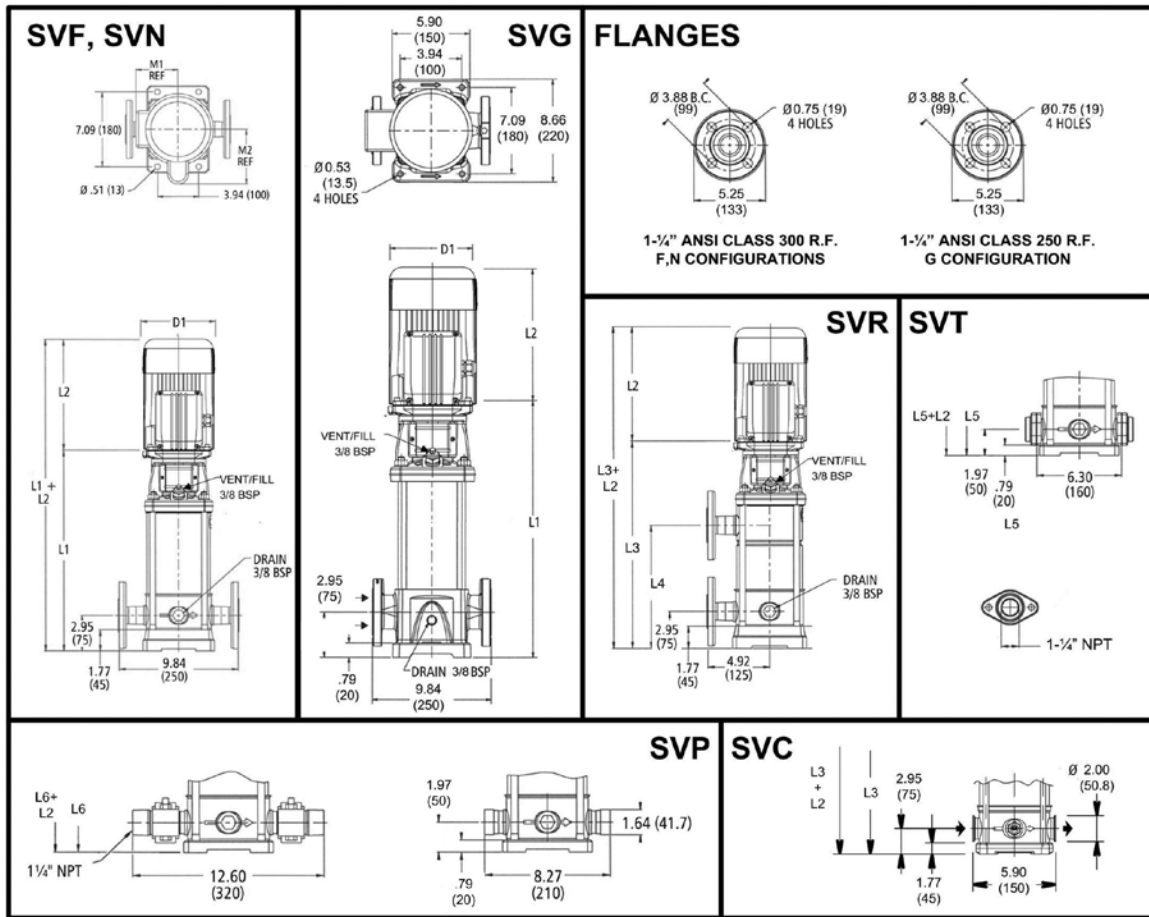

1SV SERIES – 60Hz, 3500 RPM ODP/TEFC Enclosures

Pump Type Stages	Motor				Dimensions (in)													Weight (lbs.)										
	HP	NEMA Frame				L2								D1 (max.)					D2	Pump Only	Motor				Pump/Motor			
		ODP 10	TEFC 10	ODP 30	TEFC 30	L1	ODP 10	TEFC 10	ODP 30	TEFC 30	L3	L4	L5	L6	M (Ref.)	ODP 10	TEFC 10	ODP 30			TEFC 30	ODP 10	TEFC 10	ODP 30	TEFC 30	ODP 10	TEFC 10	ODP 30
0.5	0.5	56C	13.27	9.16	9.29	9.16	9.29	-	-	12.29	12.29	5.19	6.19	6.19	6.19	6.19	4.13	25	21	21	19	19	46	46	44	44		
			13.27	9.16	9.29	9.16	9.29	-	-	12.29	12.29	5.19	6.19	6.19	6.19	6.19	4.13	26	21	21	19	19	47	47	45	45		
			14.06	9.16	9.29	9.16	9.29	-	-	13.07	13.07	5.19	6.19	6.19	6.19	6.19	4.13	27	21	21	19	19	48	48	46	46		
			14.85	9.16	9.29	9.16	9.29	-	-	13.86	13.86	5.19	6.19	6.19	6.19	6.19	4.13	28	21	21	19	19	49	49	47	47		
0.75	0.75	56C	15.63	10.79	9.91	9.16	9.29	-	-	14.65	14.65	5.19	6.19	6.19	6.19	6.19	4.13	28	27	29	21	21	55	57	49	49		
			16.42	10.79	9.91	9.16	9.29	-	-	15.44	15.44	5.19	6.19	6.19	6.19	6.19	4.13	29	27	29	21	21	56	58	50	50		
			17.21	10.79	9.91	9.16	9.29	17.21	8.94	16.22	16.22	5.19	6.19	6.19	6.19	6.19	4.13	30	27	29	21	21	57	59	51	51		
			18.00	10.66	11.19	9.16	9.29	18.00	9.72	17.01	17.01	5.74	6.19	7.19	6.19	6.19	4.13	31	32	40	23	23	63	71	54	54		
1	1	56C	18.78	10.66	11.19	9.16	9.29	18.78	10.51	17.80	17.80	5.74	6.19	7.19	6.19	6.19	4.13	32	32	40	23	23	64	72	55	55		
			19.57	10.67	11.19	10.66	9.91	19.57	11.30	18.59	18.59	5.74	6.19	7.19	6.19	6.19	4.72	33	32	40	30	28	65	73	63	61		
			20.36	10.67	11.19	10.66	9.91	20.36	12.09	19.37	19.37	5.74	6.19	7.19	6.19	6.19	4.72	34	32	40	30	28	66	74	64	62		
			21.14	10.67	11.19	10.66	9.91	21.14	12.87	20.16	20.16	5.74	6.19	7.19	6.19	6.19	4.72	35	32	40	30	28	67	75	65	63		
1.5	1.5	56C	21.93	10.67	11.19	10.66	9.91	21.93	13.66	20.95	20.95	5.74	6.19	7.19	6.19	6.19	4.72	36	32	40	30	28	68	76	66	64		
			22.72	10.67	11.19	10.66	9.91	22.72	14.45	21.74	21.74	5.74	6.19	7.19	6.19	6.19	4.72	37	32	40	30	28	69	77	67	65		
			23.51	11.18	12.06	11.16	10.79	23.51	15.24	22.52	22.52	5.74	7.19	7.19	6.19	6.19	4.72	38	43	51	32	33	81	89	70	71		
			24.29	11.18	12.06	11.16	10.79	24.29	16.02	23.31	23.31	5.74	7.19	7.19	6.19	6.19	4.72	38	43	51	32	33	81	89	70	71		
2	2	56C	25.08	11.18	12.06	11.16	10.79	25.08	16.81	24.10	24.10	5.74	7.19	7.19	6.19	6.19	4.72	39	43	51	32	33	82	90	71	72		
			25.87	11.18	12.06	11.16	10.79	25.87	17.60	-	24.89	5.74	7.19	7.19	6.19	6.19	4.72	40	43	51	32	33	83	91	72	73		
			26.66	11.18	12.06	11.16	10.79	26.66	18.39	-	25.67	5.74	7.19	7.19	6.19	6.19	4.72	41	43	51	32	33	84	92	73	74		
			27.44	11.57	13.44	11.18	11.16	27.44	19.17	-	26.46	5.75	6.50	7.19	7.16	7.19	5.51	42	49	64	41	44	91	106	83	86		
3	3	56C	28.23	11.57	13.44	11.18	11.16	28.23	19.96	-	27.25	5.75	6.50	7.19	7.16	7.19	5.51	43	49	64	41	44	92	107	84	87		
			29.02	11.57	13.44	11.18	11.16	29.02	20.75	-	28.03	5.75	6.50	7.19	7.16	7.19	5.51	45	49	64	41	44	94	109	86	89		
			29.81	11.57	13.44	11.18	11.16	29.81	21.54	-	28.82	5.75	6.50	7.19	7.16	7.19	5.51	46	49	64	41	44	95	110	87	90		
			30.59	11.57	13.44	11.18	11.16	30.59	22.32	-	29.61	5.75	6.50	7.19	7.16	7.19	5.51	47	49	64	41	44	96	111	88	91		
			31.38	11.57	13.44	11.18	11.16	31.38	23.11	-	30.40	5.75	6.50	7.19	7.16	7.19	5.51	47	49	64	41	44	96	111	88	91		
			32.17	11.57	13.44	11.18	11.16	32.17	23.90	-	31.18	5.75	6.50	7.19	7.16	7.19	5.51	48	49	64	41	44	97	112	89	92		
			32.96	11.57	13.44	11.18	11.16	32.96	24.68	-	31.97	5.75	6.50	7.19	7.16	7.19	5.51	49	49	64	41	44	98	113	90	93		
			34.14	11.57	13.44	11.18	11.16	34.14	25.47	-	33.15	5.75	6.50	7.19	7.16	7.19	5.51	50	49	64	41	44	99	114	91	94		
			34.53	11.57	13.44	11.18	11.16	-	-	-	33.55	5.75	6.50	7.19	7.16	7.19	5.51	51	49	64	41	44	100	115	92	95		

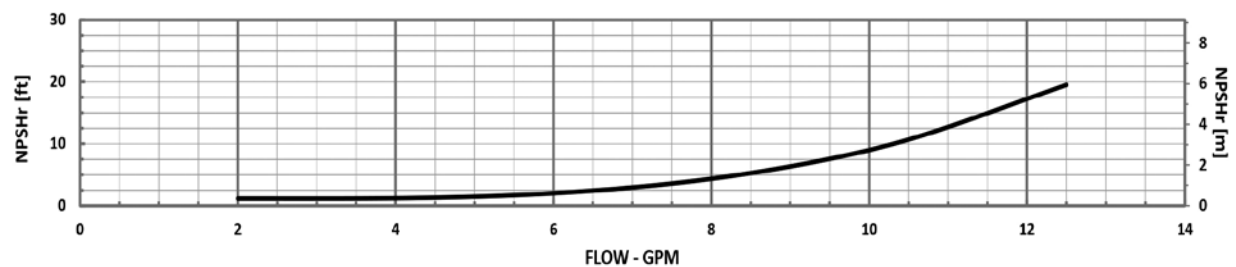
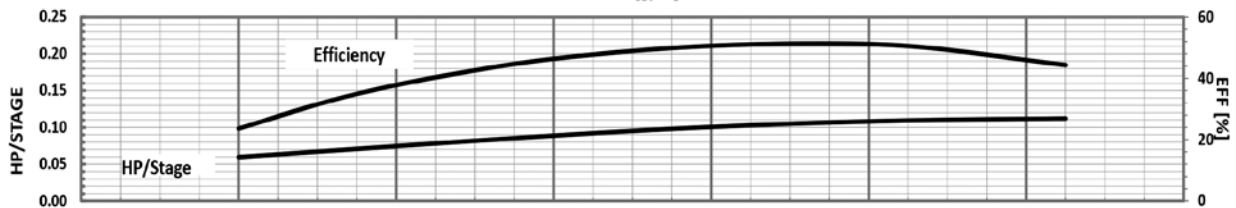
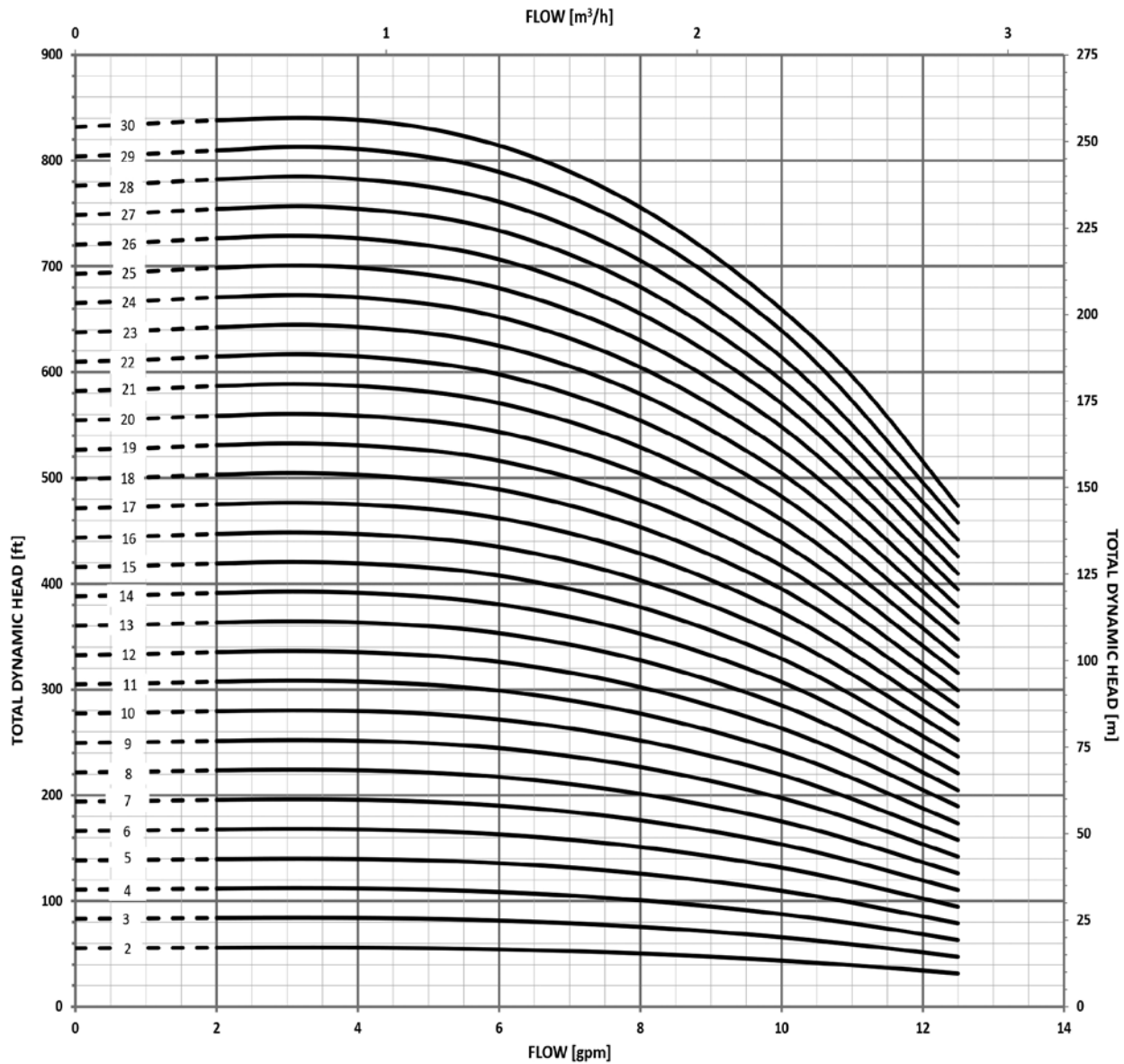

MINIMUM FLOW RATE: 2 GPM [$\frac{1}{2}$ m³/hr]

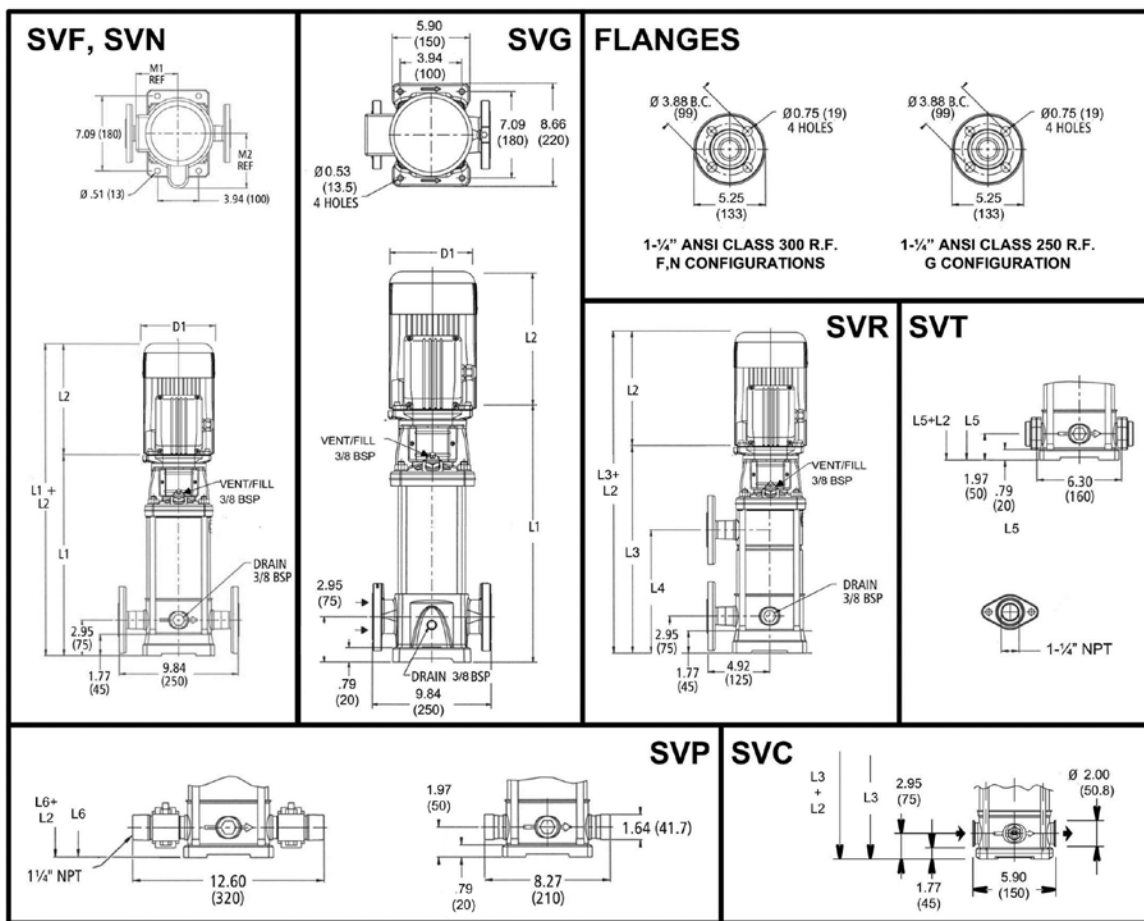

All dimensions are in inches (mm).

3SV SERIES – 60Hz, 3500 RPM ODP/TEFC Enclosures

Pump Type Stages	Motor				Dimensions (in)													Weight (lbs.)										
	HP	NEMA Frame			L2				L3	L4	L5	L6	M (Ref.)	D1 (max.)				D2	Pump Only	Motor				Pump/Motor				
		ODP 1Ø	TEFC 1Ø	ODP 3Ø	TEFC 3Ø	L1	ODP 1Ø	TEFC 1Ø						ODP 3Ø	TEFC 3Ø	ODP 1Ø	TEFC 1Ø			ODP 3Ø	TEFC 3Ø	ODP 1Ø	TEFC 1Ø	ODP 3Ø	TEFC 3Ø	ODP 1Ø	TEFC 1Ø	ODP 3Ø
3SV-02	0.5				13.27	9.16	9.29	9.16	9.29	-	-	12.29	12.29	5.19	6.19	6.19	6.19	6.19	4.13	24	21	21	19	19	45	45	43	43
3SV-03					13.27	9.16	9.29	9.16	9.29	-	-	12.29	12.29	5.19	6.19	6.19	6.19	6.19	4.13	25	21	21	19	19	46	46	44	44
3SV-04	0.75				14.06	10.79	9.91	9.16	9.29	-	-	13.07	13.07	5.19	6.19	6.19	6.19	6.19	4.13	26	27	29	21	21	53	55	47	47
3SV-05					14.85	10.66	11.19	9.16	9.29	-	-	13.86	13.86	5.74	6.19	7.19	6.19	6.19	4.13	27	32	40	23	23	59	67	50	50
3SV-06	1				15.63	10.67	11.19	10.66	9.91	-	-	14.65	14.65	5.74	6.19	7.19	6.19	6.19	4.72	28	32	40	30	28	60	68	58	56
3SV-07					16.42	10.67	11.19	10.66	9.91	-	-	15.44	15.44	5.74	6.19	7.19	6.19	6.19	4.72	30	32	40	30	28	62	70	60	58
3SV-08	1.5				17.21	10.67	11.19	10.66	9.91	17.21	8.94	16.22	16.22	5.74	6.19	7.19	6.19	6.19	4.72	31	32	40	30	28	63	71	61	59
3SV-09					18.00	11.18	12.06	11.16	10.79	18.00	9.72	17.01	17.01	5.74	7.19	7.19	6.19	6.19	4.72	32	43	51	32	33	75	83	64	65
3SV-10	2				18.78	11.18	12.06	11.16	10.79	18.78	10.51	17.80	17.80	5.74	7.19	7.19	6.19	6.19	4.72	33	43	51	32	33	76	84	65	66
3SV-11					19.57	11.18	12.06	11.16	10.79	19.57	11.30	18.59	18.59	5.74	7.19	7.19	6.19	6.19	4.72	34	43	51	32	33	77	85	66	67
3SV-12	3				20.36	11.57	13.44	11.18	11.16	20.36	12.09	19.37	19.37	5.75	7.19	7.16	7.19	5.51	35	49	64	41	44	84	99	76	79	
3SV-13					21.14	11.57	13.44	11.18	11.16	21.14	12.87	20.16	20.16	5.75	6.50	7.19	7.16	7.19	5.51	36	49	64	41	44	85	100	77	80
3SV-14	3				21.93	11.57	13.44	11.18	11.16	21.93	13.66	20.95	20.95	5.75	6.50	7.19	7.16	7.19	5.51	37	49	64	41	44	86	101	78	81
3SV-15					22.72	11.57	13.44	11.18	11.16	22.72	14.45	-	21.74	5.75	6.50	7.19	7.16	7.19	5.51	38	49	64	41	44	87	102	79	82
3SV-16	5				23.51	11.57	13.44	11.18	11.16	23.51	15.24	-	22.52	5.75	6.50	7.19	7.16	7.19	5.51	39	49	64	41	44	88	103	80	83
3SV-17					24.99	13.93	15.43	12.55	13.93	24.99	16.02	-	24.01	6.87	8.88	8.86	9.02	8.86	5.51	42	81	92	62	69	123	134	104	111
3SV-18	5				25.78	13.93	15.43	12.55	13.93	25.78	16.81	-	24.80	6.87	8.88	8.86	9.02	8.86	5.51	43	81	92	62	69	124	135	105	112
3SV-19					26.57	13.93	15.43	12.55	13.93	26.57	17.60	-	25.59	6.87	8.88	8.86	9.02	8.86	5.51	43	81	92	62	69	124	135	105	112
3SV-20	5				27.36	13.93	15.43	12.55	13.93	27.36	18.39	-	26.37	6.87	8.88	8.86	9.02	8.86	5.51	44	81	92	62	69	125	136	106	113
3SV-21					28.14	13.93	15.43	12.55	13.93	28.14	19.17	-	27.16	6.87	8.88	8.86	9.02	8.86	5.51	45	81	92	62	69	126	137	107	114
3SV-22	5	184TC	182TC	184TC	28.93	13.93	15.43	12.55	13.93	28.93	19.96	-	27.95	6.87	8.88	8.86	9.02	8.86	5.51	46	81	92	62	69	127	138	108	115
3SV-23					29.72	13.93	15.43	12.55	13.93	29.72	20.75	-	28.73	6.87	8.88	8.86	9.02	8.86	5.51	47	81	92	62	69	128	139	109	116
3SV-24	5				30.51	13.93	15.43	12.55	13.93	-	-	-	29.52	6.87	8.88	8.86	9.02	8.86	5.51	48	81	92	62	69	129	140	110	117
3SV-25					31.29	13.93	15.43	12.55	13.93	-	-	-	30.31	6.87	8.88	8.86	9.02	8.86	5.51	49	81	92	62	69	130	141	111	118
3SV-26	5				32.08	13.93	15.43	12.55	13.93	-	-	-	31.10	6.87	8.88	8.86	9.02	8.86	5.51	50	81	92	62	69	131	142	112	119
3SV-27					32.47	13.93	15.43	12.55	13.93	-	-	-	31.49	6.87	8.88	8.86	9.02	8.86	5.51	52	81	92	62	69	133	144	114	121
3SV-28	7.5				33.26	13.88	15.53	13.93	15.43	-	-	-	32.28	8.05	8.88	8.86	9.02	8.86	5.51	53	100	120	75	85	153	173	128	138
3SV-29					34.44	13.88	15.53	13.93	15.43	-	-	-	33.46	8.05	8.89	10.62	8.88	8.86	5.51	54	100	120	75	85	154	174	129	139
3SV-30	7.5				35.23	13.88	15.53	13.93	15.43	-	-	-	34.25	8.05	8.89	10.62	8.88	8.86	5.51	55	100	120	75	85	155	175	130	140

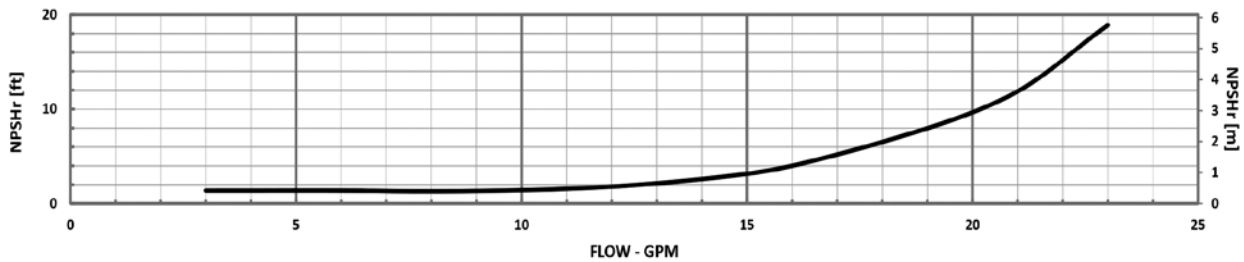
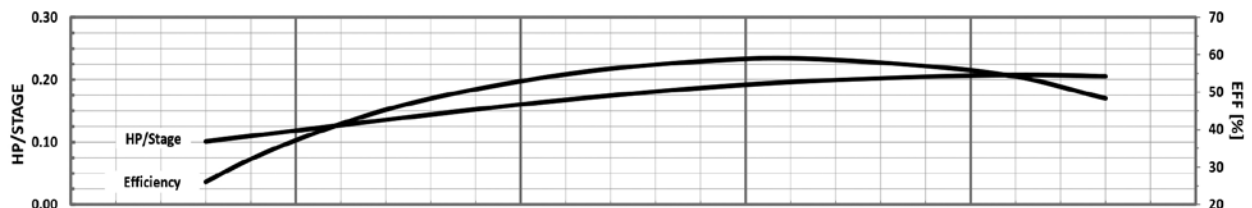
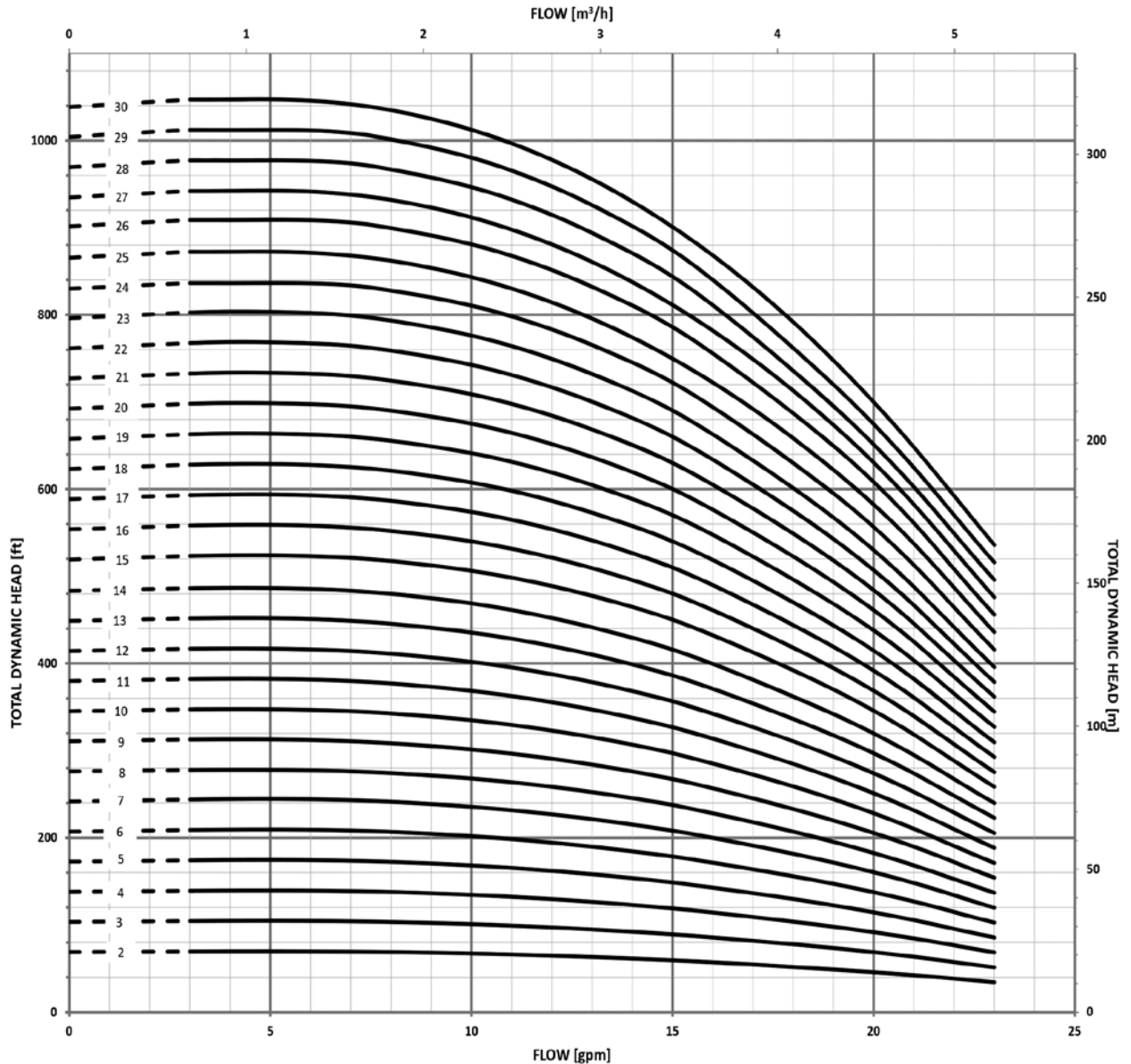

MINIMUM FLOW RATE: 3 GPM [.68 m³/hr]

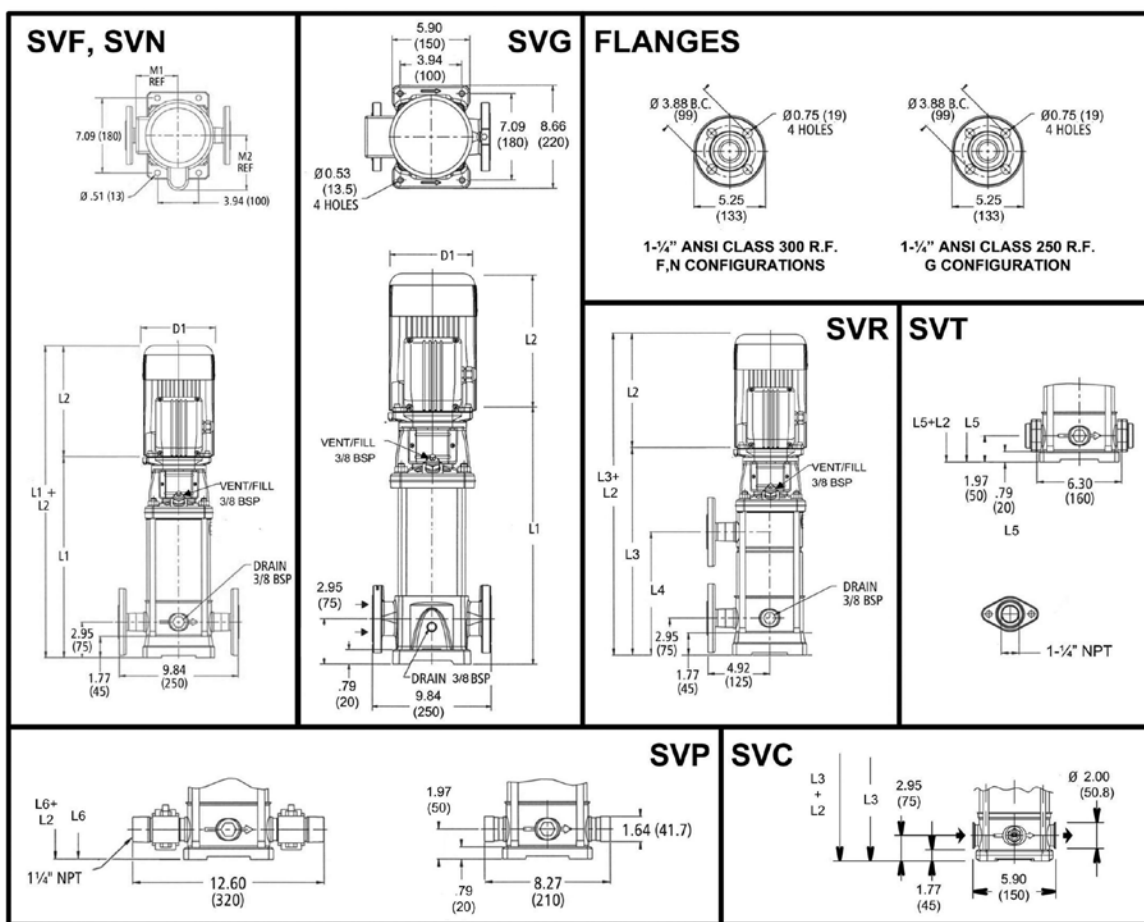

5SV SERIES – 60Hz, 3500 RPM ODP/TEFC Enclosures

Pump Type Stages	Motor				Dimensions (in)											Weight (lbs.)														
	HP	NEMA Frame				L2				L3	L4	L5	L6	M (Ref.)	D1 (max.)				D2	Pump Only	Motor				Pump/Motor					
		ODP 1Ø	TEFC 1Ø	ODP 3Ø	TEFC 3Ø	L1	ODP 1Ø	TEFC 1Ø	ODP 3Ø						TEFC 3Ø	ODP 1Ø	TEFC 1Ø	ODP 3Ø			TEFC 3Ø	ODP 1Ø	TEFC 1Ø	ODP 3Ø	TEFC 3Ø	ODP 1Ø	TEFC 1Ø	ODP 3Ø	TEFC 3Ø	
5SV-02	0.75	56C				13.86	10.79	9.91	9.16	9.29	-	-	12.88	12.88	5.19	6.19	6.19	6.19	6.19	4.13	25	27	29	21	21	52	54	46	46	
5SV-03	1					13.86	10.66	11.19	9.16	9.29	-	-	12.88	12.88	5.74	6.19	7.19	6.19	6.19	6.19	4.13	26	32	40	23	23	58	66	49	49
5SV-04	1.5					14.85	10.67	11.19	10.66	9.91	-	-	13.86	13.86	5.74	6.19	7.19	6.19	6.19	6.19	4.72	28	32	40	30	28	60	68	58	56
5SV-05	2					15.83	10.67	11.19	10.66	9.91	-	-	14.85	14.85	5.74	6.19	7.19	6.19	6.19	6.19	4.72	29	32	40	30	28	61	69	59	57
5SV-06	2					16.81	11.18	12.06	11.16	10.79	-	-	15.83	15.83	5.74	7.19	7.19	6.19	6.19	6.19	4.72	30	43	51	32	33	73	81	62	63
5SV-07	2					17.80	11.18	12.06	11.16	10.79	17.80	9.53	16.81	16.81	5.74	7.19	7.19	6.19	6.19	6.19	4.72	31	43	51	32	33	74	82	63	64
5SV-08	3					18.78	11.57	13.44	11.18	11.16	18.78	10.51	17.80	17.80	5.75	6.50	7.19	7.16	7.19	5.51	33	49	64	41	44	82	97	74	77	
5SV-09	3					19.77	11.57	13.44	11.18	11.16	19.77	11.50	18.78	18.78	5.75	6.50	7.19	7.16	7.19	5.51	33	49	64	41	44	82	97	74	77	
5SV-10	3					20.75	11.57	13.44	11.18	11.16	20.75	12.48	19.77	19.77	5.75	6.50	7.19	7.16	7.19	5.51	34	49	64	41	44	83	98	75	78	
5SV-11	5					184TC	182TC	184TC	22.44	13.93	15.43	12.55	13.93	22.44	13.46	21.45	21.45	6.87	8.88	8.86	9.02	8.86	5.51	37	81	92	62	69	118	129
5SV-12		23.42	13.93	15.43	12.55				13.93	23.42	14.45	22.44	22.44	6.87	8.88	8.86	9.02	8.86	5.51	38	81	92	62	69	119	130	100	107		
5SV-13		24.40	13.93	15.43	12.55				13.93	24.40	15.43	23.42	23.42	6.87	8.88	8.86	9.02	8.86	5.51	40	81	92	62	69	121	132	102	109		
5SV-14		25.39	13.93	15.43	12.55				13.93	25.39	16.42	24.40	24.40	6.87	8.88	8.86	9.02	8.86	5.51	40	81	92	62	69	121	132	102	109		
5SV-15		26.37	13.93	15.43	12.55				13.93	26.37	17.40	-	25.39	6.87	8.88	8.86	9.02	8.86	5.51	41	81	92	62	69	122	133	103	110		
5SV-16		27.36	13.93	15.43	12.55				13.93	27.36	18.39	-	26.37	6.87	8.88	8.86	9.02	8.86	5.51	43	81	92	62	69	124	135	105	112		
5SV-17		28.54	13.93	15.43	12.55				13.93	28.54	19.37	-	27.55	6.87	8.88	8.86	9.02	8.86	5.51	45	81	92	62	69	126	137	107	114		
5SV-18		7.5	213TC	184TC	29.33				13.88	15.53	13.93	15.43	29.33	20.35	-	28.34	8.05	8.89	10.62	8.88	8.86	5.51	46	100	120	75	85	146	166	121
5SV-19	30.51				13.88	15.53	13.93	15.43	30.51	21.34	-	29.52	8.05	8.89	10.62	8.88	8.86	5.51	47	100	120	75	85	147	167	122	132			
5SV-20	31.69				13.88	15.53	13.93	15.43	31.69	22.32	-	30.70	8.05	8.89	10.62	8.88	8.86	5.51	48	100	120	75	85	148	168	123	133			
5SV-21	32.28				13.88	15.53	13.93	15.43	32.28	23.31	-	31.29	8.05	8.89	10.62	8.88	8.86	5.51	49	100	120	75	85	149	169	124	134			
5SV-22	33.34				13.88	15.53	13.93	15.43	33.34	24.29	-	32.36	8.05	8.89	10.62	8.88	8.86	5.51	50	100	120	75	85	150	170	125	135			
5SV-23	34.25				13.88	15.53	13.93	15.43	34.25	25.28	-	33.26	8.05	8.89	10.62	8.88	8.86	5.51	51	100	120	75	85	151	171	126	136			
5SV-24	35.31				13.88	15.53	13.93	15.43	-	-	-	34.33	8.05	8.89	10.62	8.88	8.86	5.51	53	100	120	75	85	153	173	128	138			
5SV-25	36.21				13.88	15.53	13.93	15.43	-	-	-	35.23	8.05	8.89	10.62	8.88	8.86	5.51	53	100	120	75	85	153	173	128	138			
5SV-26	37.28				13.88	15.53	13.93	15.43	-	-	-	36.29	8.05	8.89	10.62	8.88	8.86	5.51	54	100	120	75	85	154	174	129	139			
5SV-27	10	215TC	213TC	215TC	38.84	16.63	16.68	15.55	15.51	-	-	-	37.86	8.77	10.62	10.18	10.18	10.28	5.51	62	132	145	107	122	194	207	169	184		

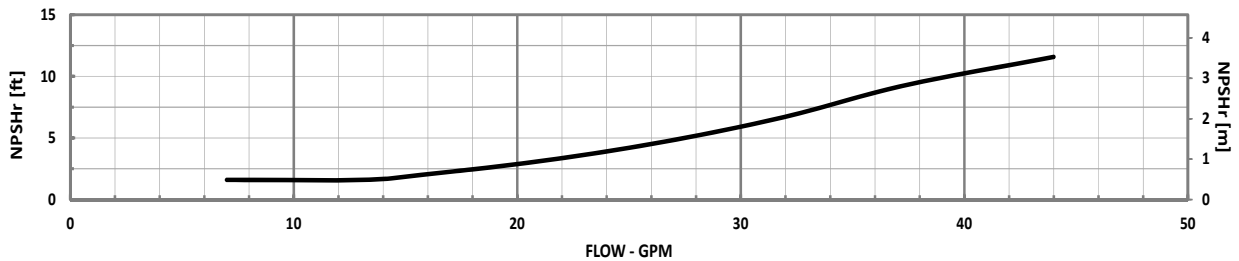
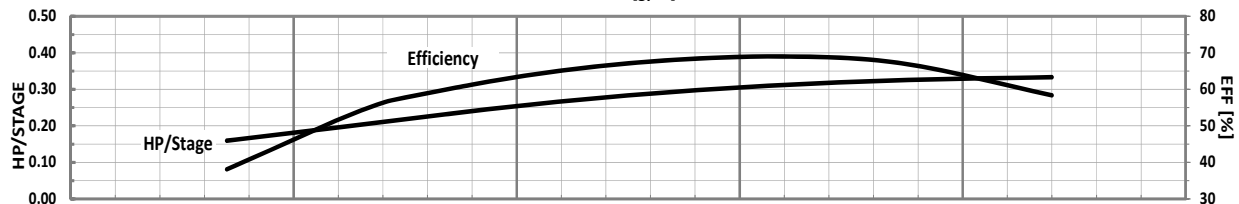
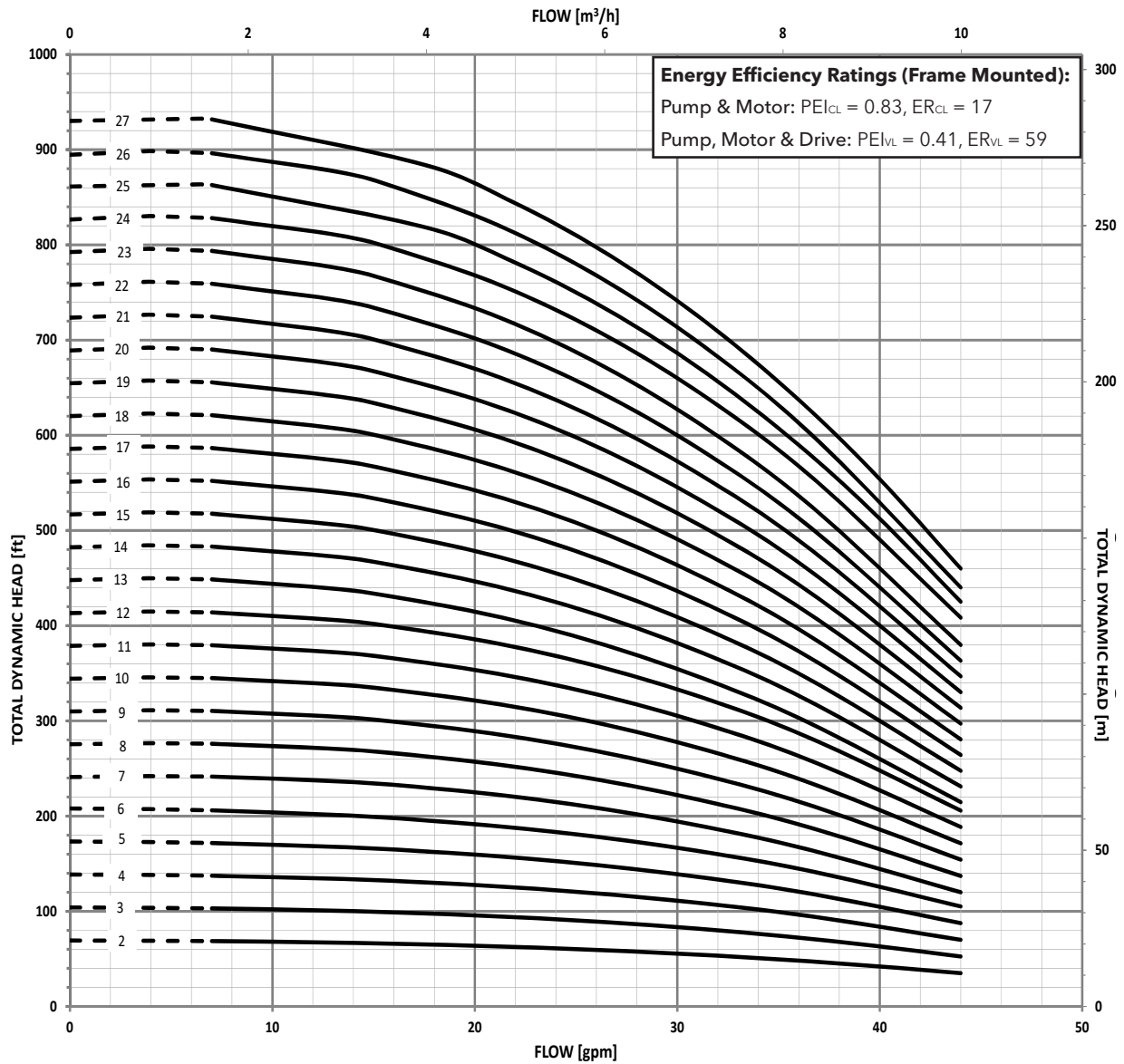

MINIMUM FLOW RATE: 7 GPM [1.6 m³/hr]

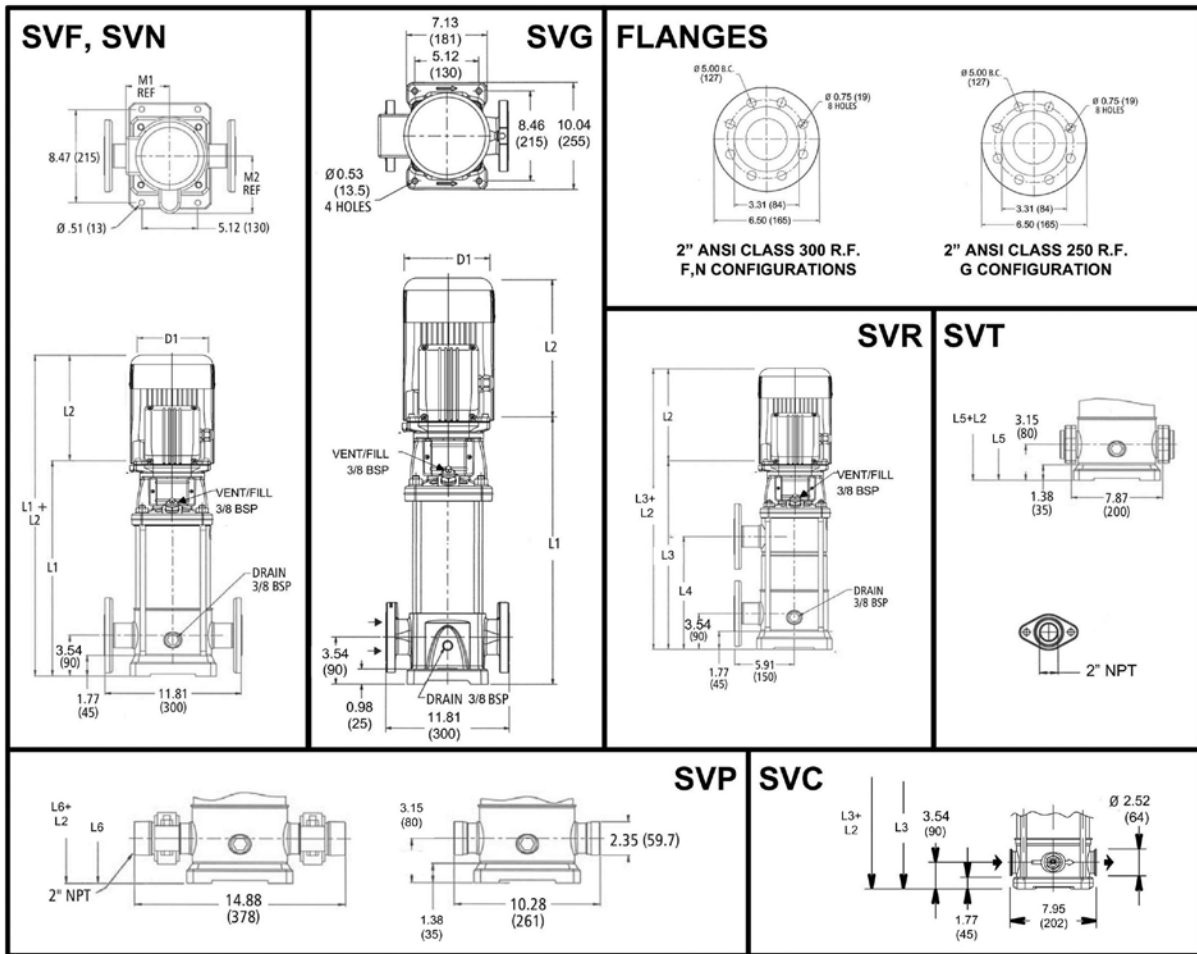

All dimensions are in inches (mm).

10SV SERIES – 60Hz, 3500 RPM ODP/TEFC Enclosures

Pump Type Stages	Motor		Dimensions (in)														Weight (lbs.)												
			NEMA Frame				L2				L3				D1 (max.)				Motor				Pump/Motor						
	HP	ODP 1Ø	TEFC 1Ø	ODP 3Ø	TEFC 3Ø	L1	ODP 1Ø	TEFC 1Ø	ODP 3Ø	TEFC 3Ø	L3	L4	L5	L6	M (Ref.)	ODP 1Ø	TEFC 1Ø	ODP 3Ø	TEFC 3Ø	D2	Pump Only	ODP 1Ø	TEFC 1Ø	ODP 3Ø	TEFC 3Ø	ODP 1Ø	TEFC 1Ø	ODP 3Ø	TEFC 3Ø
10SV-01	0.75	56C				16.56	10.79	9.91	9.16	9.29	-	-	16.17	16.17	5.19	6.19	6.19	6.19	6.19	4.13	36	27	29	21	21	63	65	57	57
10SV-02	2	56C				16.56	11.18	12.06	11.16	10.79	-	-	16.17	16.17	5.74	7.19	7.19	6.19	6.19	4.72	38	43	51	32	33	81	89	70	71
10SV-03	3	56C				17.82	11.57	13.44	11.18	11.16	-	-	17.43	17.43	5.75	6.50	7.19	7.16	7.19	5.51	40	49	64	41	44	89	104	81	84
10SV-04	5	184TC	182TC	184TC	19.58	13.93	15.43	12.55	13.93	-	-	19.19	19.19	6.87	8.88	8.86	9.02	8.86	5.51	46	81	92	62	69	127	138	108	115	
10SV-05	5				20.84	13.93	15.43	12.55	13.93	20.84	10.20	20.45	20.45	6.87	8.88	8.86	9.02	8.86	5.51	48	81	92	62	69	129	140	110	117	
10SV-06	5	184TC	182TC	184TC	22.10	13.93	15.43	12.55	13.93	22.10	11.46	21.71	21.71	6.87	8.88	8.86	9.02	8.86	5.51	50	81	92	62	69	131	142	112	119	
10SV-07	5				23.36	13.88	15.53	13.93	15.43	23.36	12.72	22.97	22.97	8.05	8.89	10.62	8.88	8.86	5.51	52	100	120	75	85	152	172	127	137	
10SV-08	7.5	213TC	184TC	184TC	24.62	13.88	15.53	13.93	15.43	24.62	13.98	24.22	24.22	8.05	8.89	10.62	8.88	8.86	5.51	54	100	120	75	85	154	174	129	139	
10SV-09	7.5				25.88	13.88	15.53	13.93	15.43	25.88	15.24	25.48	25.48	8.05	8.89	10.62	8.88	8.86	5.51	56	100	120	75	85	156	176	131	141	
10SV-10	10	215TC	213TC	215TC	27.71	16.63	16.68	15.55	15.51	27.71	16.50	-	27.31	8.77	10.62	10.18	10.18	10.28	5.51	66	132	145	107	122	198	211	173	188	
10SV-11	10				28.97	16.63	16.68	15.55	15.51	28.97	17.76	-	28.57	8.77	10.62	10.18	10.18	10.28	5.51	68	132	145	107	122	200	213	175	190	
10SV-12	10				29.44	16.63	16.68	15.55	15.51	29.44	19.02	-	29.05	8.77	10.62	10.18	10.18	10.28	5.51	70	132	145	107	122	202	215	177	192	
10SV-13	10				31.51	16.63	16.68	15.55	15.51	31.51	20.28	-	31.11	8.77	10.62	10.18	10.18	10.28	5.51	75	132	145	107	122	207	220	182	197	
10SV-14	15	215TC	254TC	215TC	32.85	16.63	16.68	15.55	15.51	32.85	21.54	-	32.45	8.77	10.62	10.18	10.28	5.51	77	132	145	107	122	209	222	184	199		
10SV-15	15				34.66	-	-	15.55	16.57	-	-	-	34.26	9.22	-	-	10.18	10.28	5.51	84	-	-	125	195	-	-	209	279	
10SV-16	15				35.92	-	-	15.55	16.57	-	-	-	35.52	9.22	-	-	10.18	10.28	5.51	86	-	-	125	195	-	-	211	281	
10SV-17	15				37.18	-	-	15.55	16.57	-	-	-	36.78	9.22	-	-	10.18	10.28	5.51	88	-	-	125	195	-	-	213	283	
10SV-18	15				38.44	-	-	15.55	16.57	-	-	-	38.04	9.22	-	-	10.18	10.28	5.51	90	-	-	125	195	-	-	215	285	
10SV-19	15				39.78	-	-	15.55	16.57	-	-	-	39.38	9.22	-	-	10.18	10.28	5.51	92	-	-	125	195	-	-	217	287	
10SV-20	20	254TC	256TC	256TC	40.96	-	-	16.66	20.08	-	-	-	40.56	9.5	-	-	10.18	13.13	5.51	94	-	-	144	285	-	-	238	379	

* Please refer to motor table for frame size

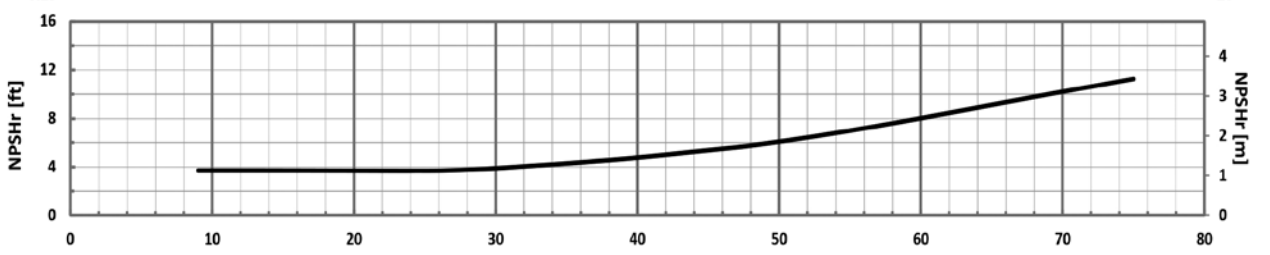
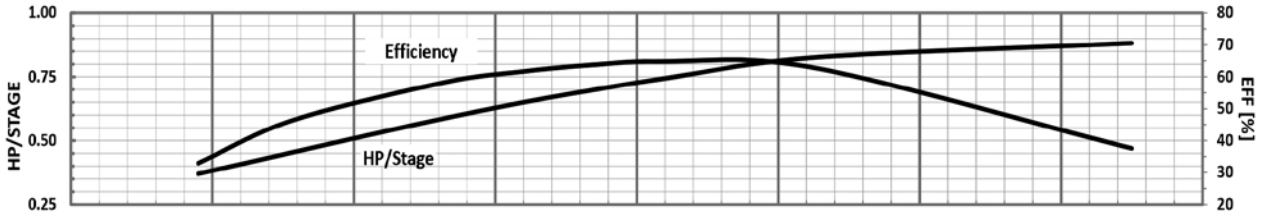
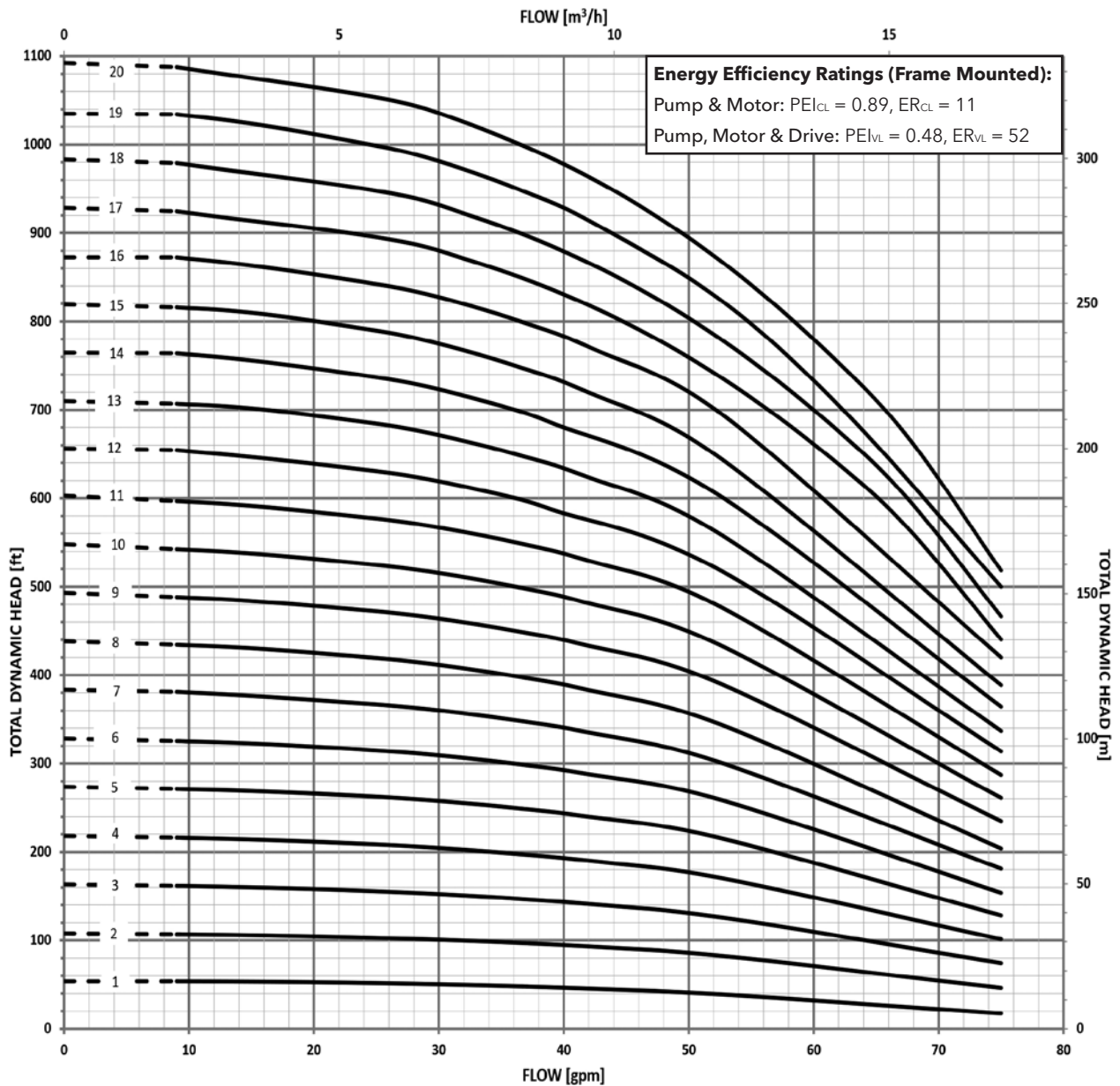

MINIMUM FLOW RATE: 9 GPM [2 m³/hr]

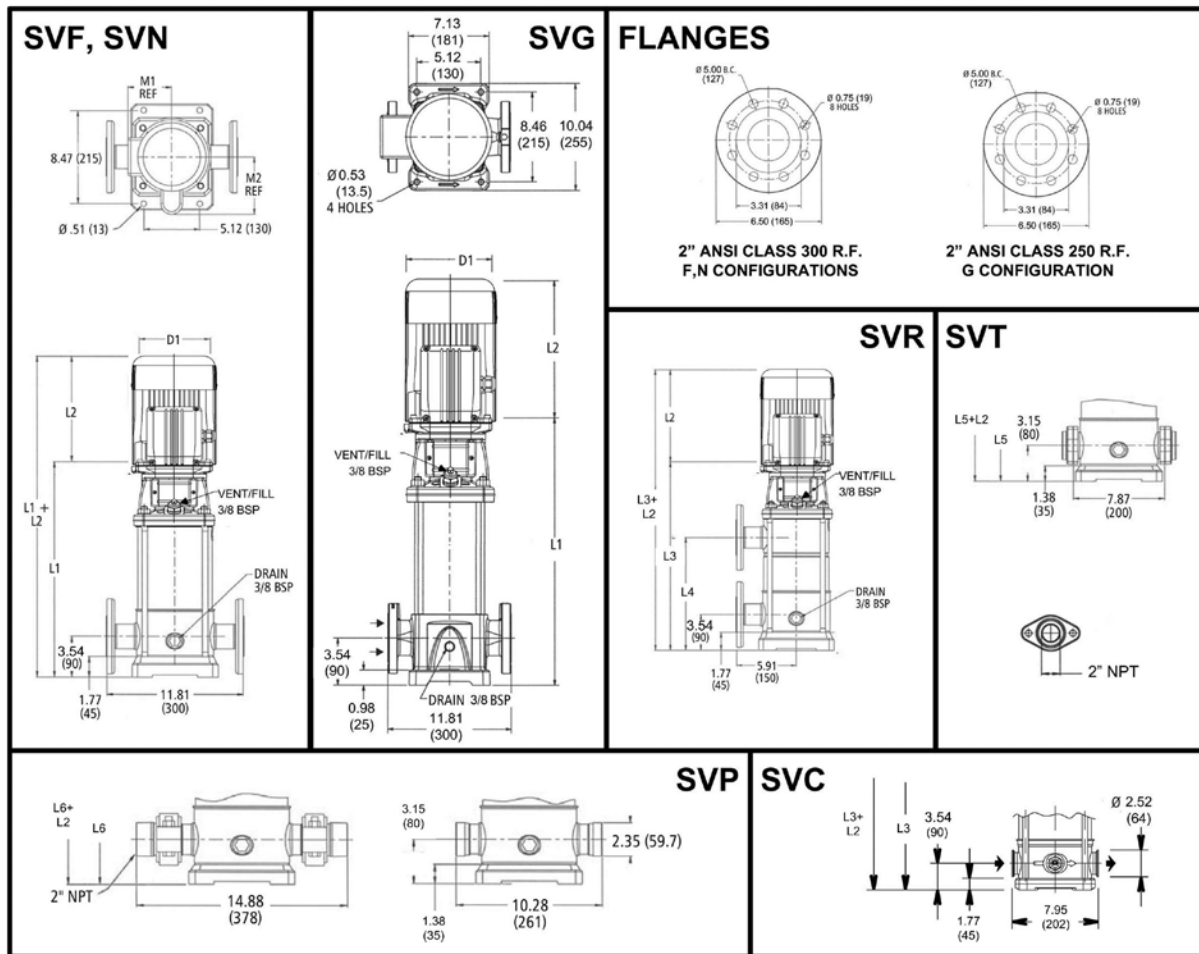

All dimensions are in inches (mm).

15SV SERIES – 60Hz, 3500 RPM ODP/TEFC Enclosures

Pump Type Stages	Motor				Dimensions (in)												Weight (lbs.)												
	HP	NEMA Frame			L1	L2				L3	L4	L5	L6	M (Ref.)	D1 (max.)				D2	Pump Only	Motor				Pump/Motor				
		ODP 1Ø	TEFC 1Ø	ODP 3Ø		TEFC 3Ø	ODP 1Ø	TEFC 1Ø	ODP 3Ø						TEFC 3Ø	ODP 1Ø	TEFC 1Ø	ODP 3Ø			TEFC 3Ø	ODP 1Ø	TEFC 1Ø	ODP 3Ø	TEFC 3Ø	ODP 1Ø	TEFC 1Ø	ODP 3Ø	TEFC 3Ø
15SV-01	2	56C			18.61	11.18	12.06	11.16	10.79	-	-	18.21	18.21	5.74	7.19	7.19	6.19	6.19	4.72	38	43	51	32	33	81	89	70	71	
15SV-02	5	184TC	182TC	184TC	18.71	13.93	15.43	12.55	13.93	-	-	18.32	18.32	6.87	8.88	8.86	9.02	8.86	5.51	44	81	92	62	69	125	136	106	113	
15SV-03					20.60	13.93	15.43	12.55	13.93	-	-	20.21	20.21	6.87	8.88	8.86	9.02	8.86	5.51	47	81	92	62	69	128	139	109	116	
15SV-04	7.5	213TC	184TC		22.49	13.88	15.53	13.93	15.43	22.49	11.85	22.10	22.10	8.05	8.89	10.62	8.88	8.86	5.51	50	100	120	75	85	150	170	125	135	
15SV-05	10	215TC	213TC	215TC	24.95	16.63	16.68	15.55	15.51	24.95	13.74	24.56	24.56	8.77	10.62	10.18	10.18	10.28	5.51	59	132	145	107	122	191	204	166	181	
15SV-06					26.86	16.63	16.68	15.55	15.51	26.86	15.63	26.47	26.47	8.77	10.62	10.18	10.18	10.28	5.51	66	132	145	107	122	198	211	173	188	
15SV-07	15	215TC	254TC	215TC	29.38	-	-	15.55	16.57	29.38	17.52	28.99	28.99	9.22	-	-	10.18	10.28	5.51	74	-	-	125	195	-	-	199	269	
15SV-08					31.27	-	-	15.55	16.57	31.27	19.41	-	30.88	9.22	-	-	10.18	10.28	5.51	76	-	-	125	195	-	-	201	271	
15SV-09					33.16	-	-	15.55	16.57	33.16	21.30	-	32.77	9.22	-	-	10.18	10.28	5.51	79	-	-	125	195	-	-	204	274	
15SV-10	20	215TC	256TC	254TC	35.05	-	-	16.66	20.08	35.05	23.19	-	34.66	9.5	-	-	10.18	13.13	5.51	83	-	-	144	285	-	-	227	368	
15SV-11					36.94	-	-	16.66	20.08	36.94	25.08	-	36.55	9.5	-	-	10.18	13.13	5.51	86	-	-	144	285	-	-	230	371	
15SV-12					38.83	-	-	16.66	20.08	-	-	-	38.44	9.5	-	-	10.18	13.13	5.51	89	-	-	144	285	-	-	233	374	
15SV-13	25	215TC	284TC	254TC	41.35	-	-	21.44	19.54	-	-	-	-	40.96	12.94	-	-	11.63	12.94	5.51	100	-	-	185	283	-	-	285	383
15SV-14					43.24	-	-	21.44	19.54	-	-	-	42.85	12.94	-	-	11.63	12.94	5.51	103	-	-	185	283	-	-	288	386	
15SV-15	45.13	-	-	21.44	19.54	-	-	-	44.74	12.94	-	-	11.63	12.94	5.51	106	-	-	185	283	-	-	291	389					

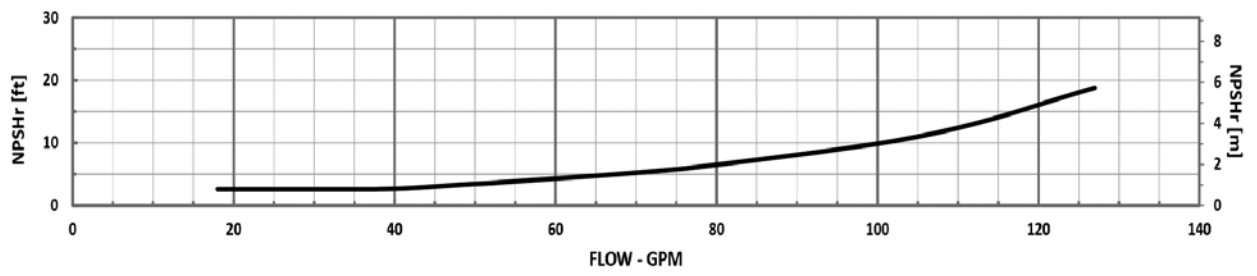
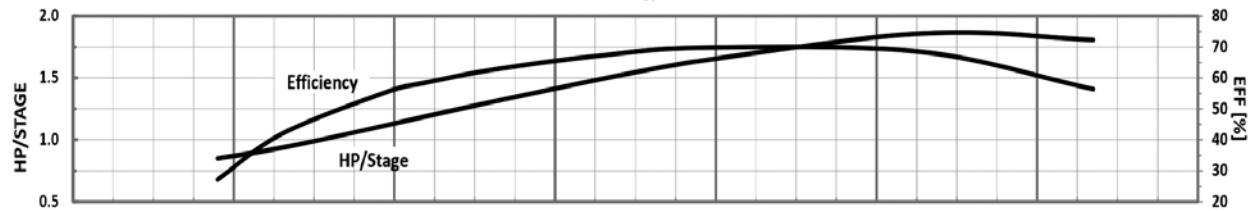
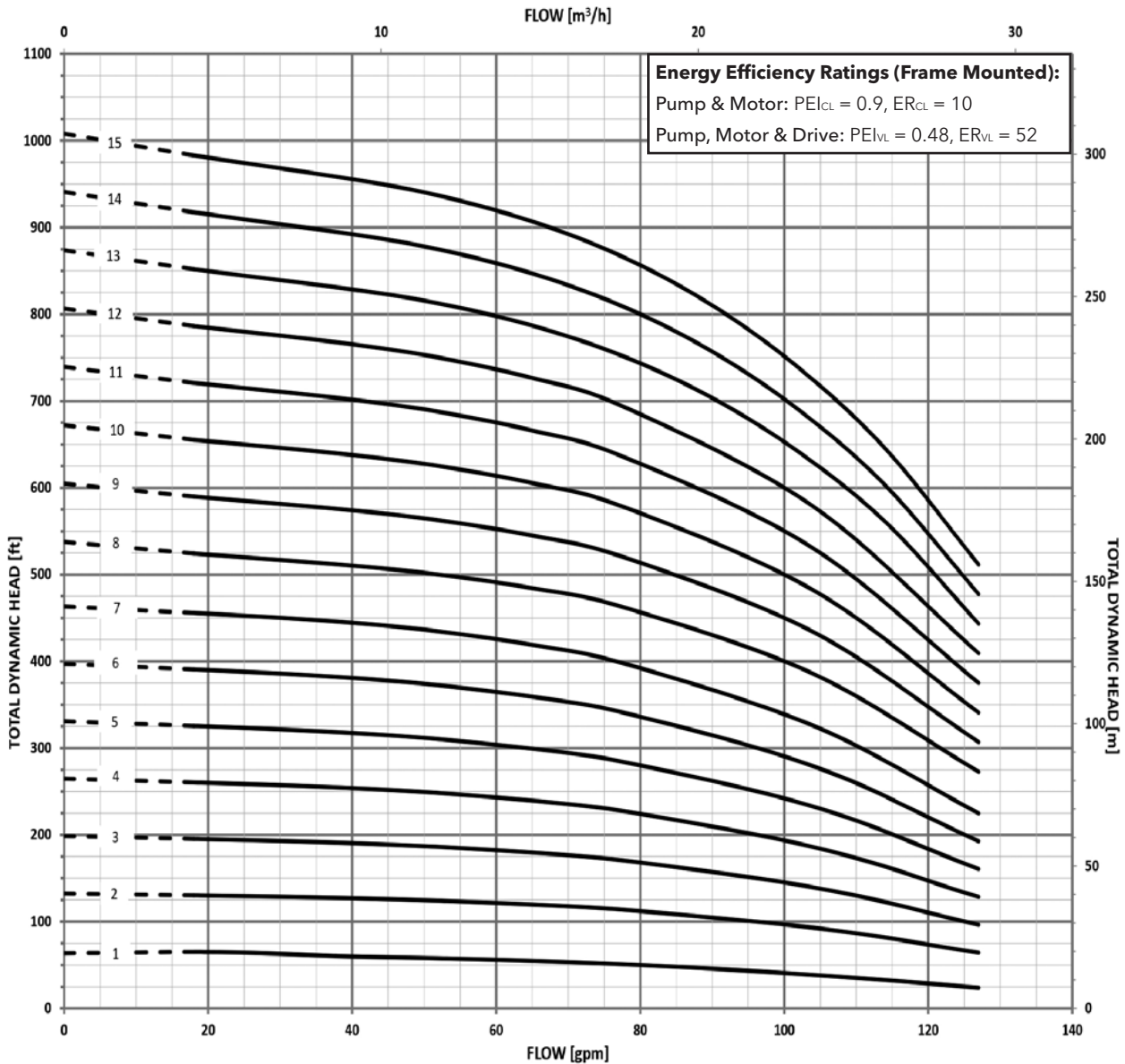

MINIMUM FLOW RATE: 18 GPM [4.1 m³/hr]

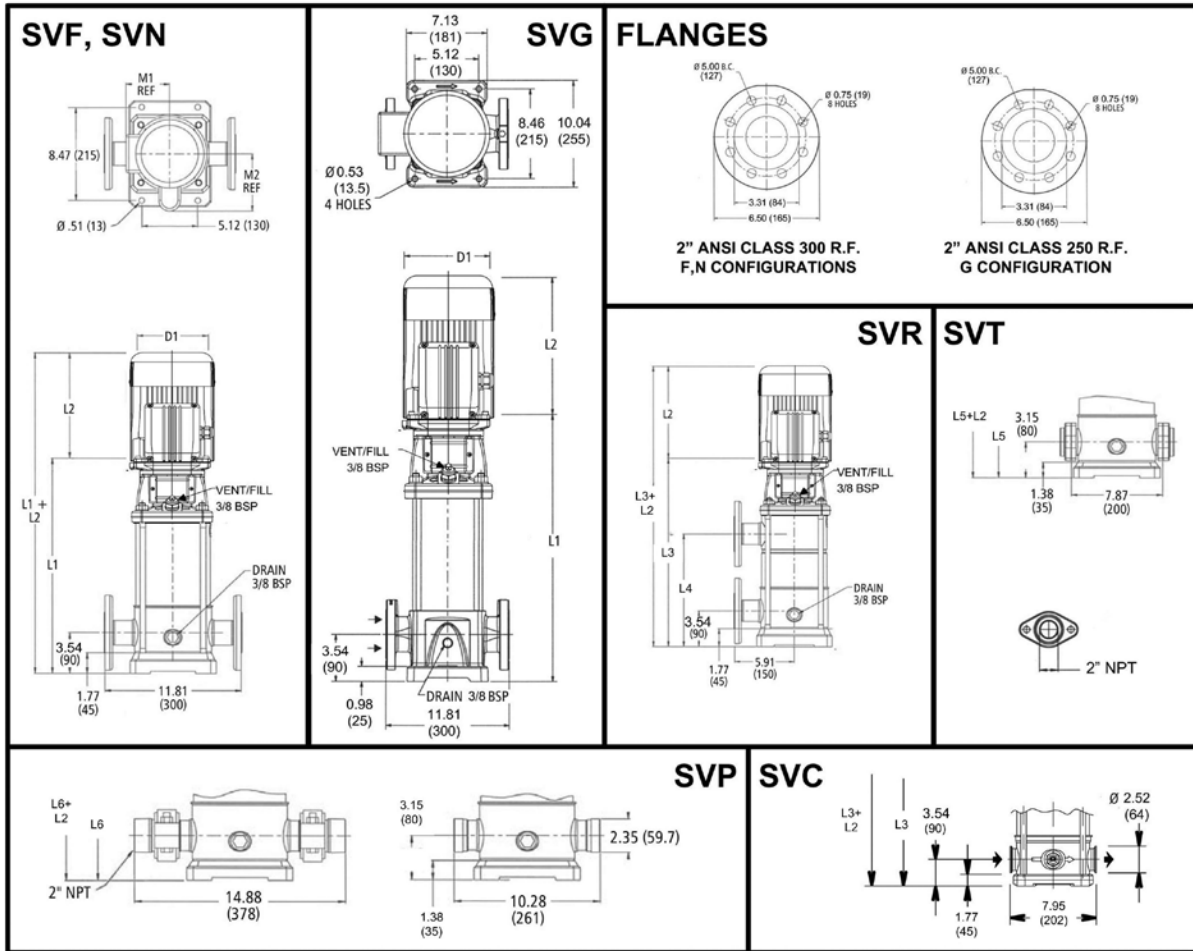

All dimensions are in inches (mm).

22SV SERIES – 60Hz, 3500 RPM ODP/TEFC Enclosures

Pump Type Stages	Motor				Dimensions (in)													Weight (lbs.)										
	HP	NEMA Frame			L1	L2				L3	L4	L5	L6	M (Ref.)	D1 (max.)				D2	Pump Only	Motor				Pump/Motor			
		ODP 10	TEFC 10	ODP 30		TEFC 30	ODP 10	TEFC 10	ODP 30						TEFC 30	ODP 10	TEFC 10	ODP 30			TEFC 30	ODP 10	TEFC 10	ODP 30	TEFC 30	ODP 10	TEFC 10	ODP 30
22SV-01	3	56C			18.61	11.57	13.44	11.18	11.16	-	-	18.21	18.21	5.75	6.50	7.19	7.16	7.19	5.51	39	49	64	41	44	88	103	80	83
22SV-02	5	184TC	182TC	184TC	18.71	13.93	15.43	12.55	13.93	-	-	18.32	18.32	6.87	8.88	8.86	9.02	8.86	5.51	45	81	92	62	69	126	137	107	114
22SV-03	7.5	213TC	184TC		20.60	13.88	15.53	13.93	15.43	-	-	20.21	20.21	8.05	8.89	10.62	8.88	8.86	5.51	48	100	120	75	85	148	168	123	133
22SV-04	10	215TC	213TC	215TC	23.06	16.63	16.68	15.55	15.51	23.06	11.85	22.67	22.67	8.77	10.62	10.18	10.18	10.28	5.51	58	132	145	107	122	190	203	165	180
22SV-05	15	215TC 254TC			25.60	-	-	15.55	16.57	25.60	13.74	25.21	25.21	9.22	-	-	10.18	10.28	5.51	66	-	-	125	195	-	-	191	261
22SV-06	27.49				-	-	15.55	16.57	27.49	15.63	27.10	27.10	9.22	-	-	10.18	10.28	5.51	69	-	-	125	195	-	-	194	264	
22SV-07	29.38				-	-	15.55	16.57	29.38	17.52	28.99	28.99	9.22	-	-	10.18	10.28	5.51	72	-	-	125	195	-	-	197	267	
22SV-08	31.27				-	-	16.66	20.08	31.27	19.41	-	30.88	9.50	-	-	10.18	13.13	5.51	75	-	-	144	285	-	-	219	360	
22SV-09	20	254TC			33.16	-	-	16.66	20.08	33.16	21.30	-	32.77	9.50	-	-	10.18	13.13	5.51	77	-	-	144	285	-	-	221	362
22SV-10	35.68				-	-	21.44	19.54	35.68	23.19	-	35.29	12.94	-	-	11.63	12.94	5.51	89	-	-	185	283	-	-	274	372	
22SV-11	37.57				-	-	21.44	19.54	37.57	25.08	-	37.18	12.94	-	-	11.63	12.94	5.51	92	-	-	185	283	-	-	277	375	
22SV-12	25	284TC			39.46	-	-	21.44	19.54	-	-	-	39.07	12.94	-	-	11.63	12.94	5.51	95	-	-	185	283	-	-	280	378

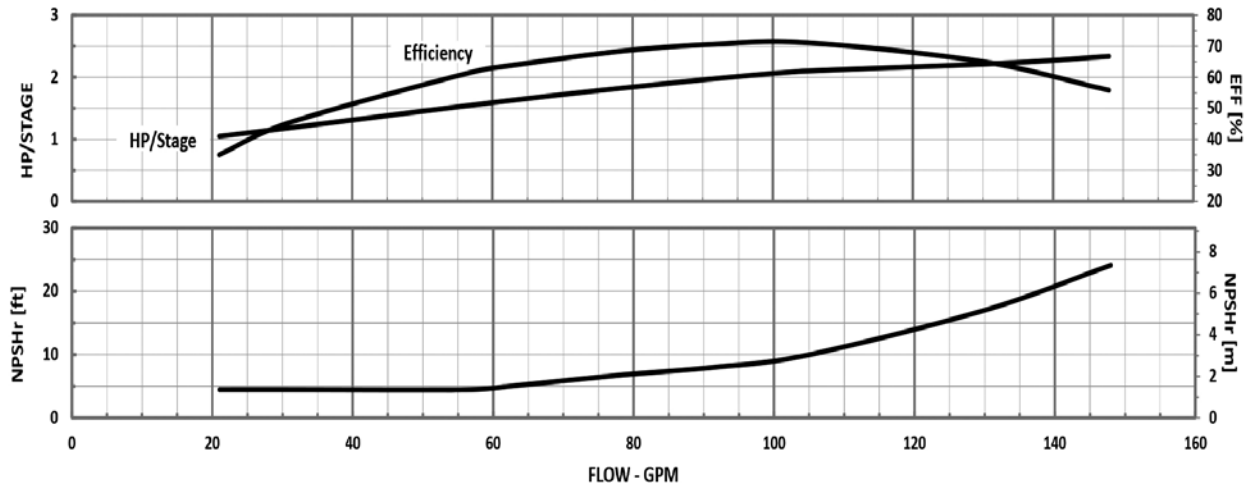
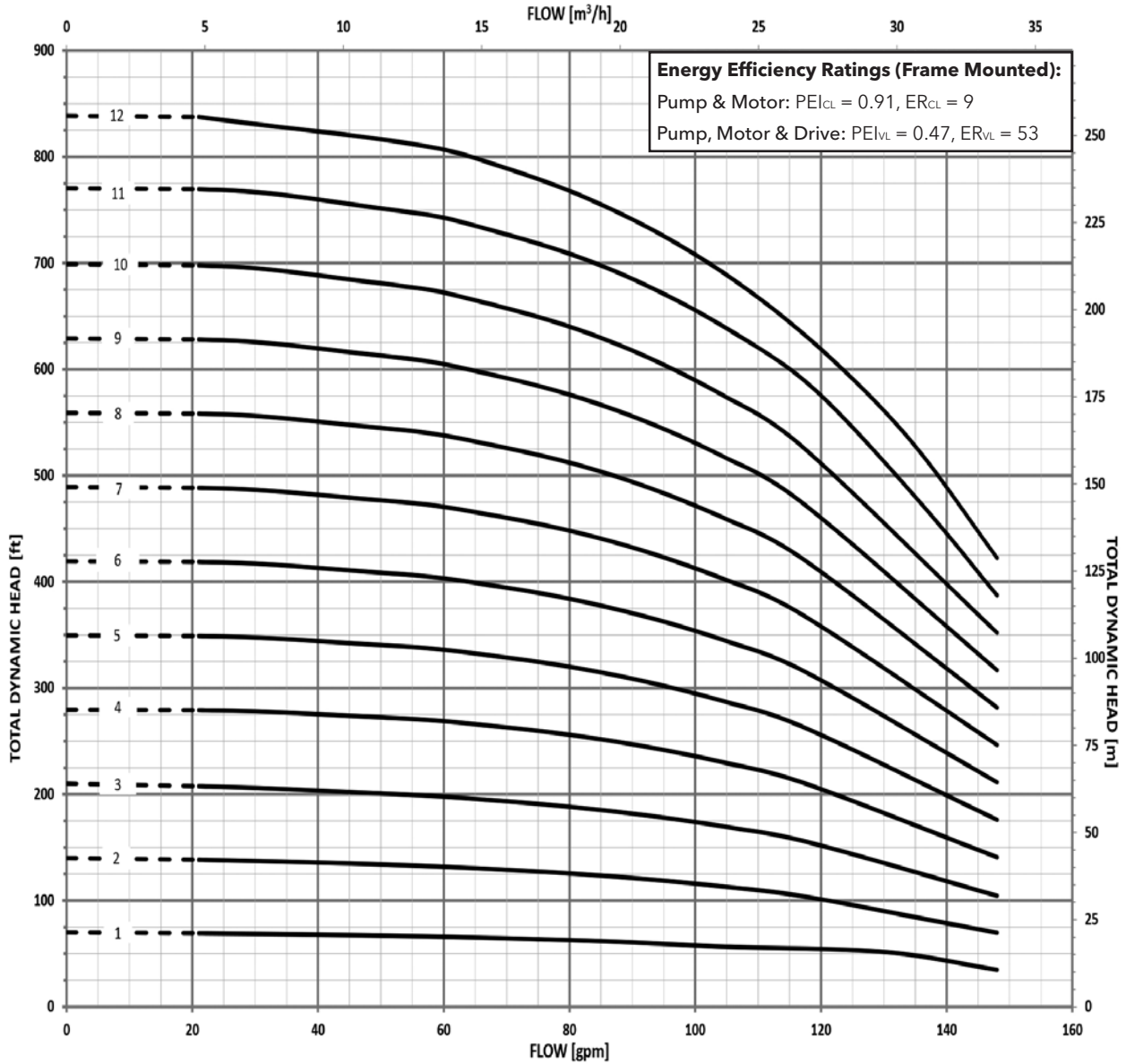

MINIMUM FLOW RATE: 21 GPM [4.8 m³/hr]

Commercial Water

Dimensions and Weights

33SV Series 3500 RPM

60 Hz

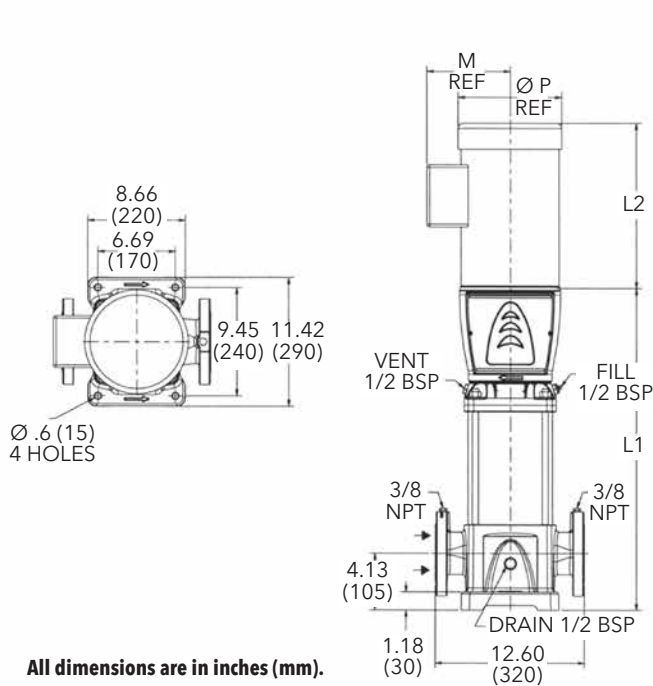

All dimensions are in inches (mm).

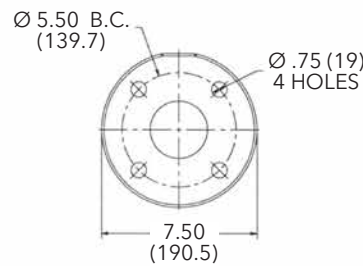

Cast Iron
2 1/2" Class 125 F.F.

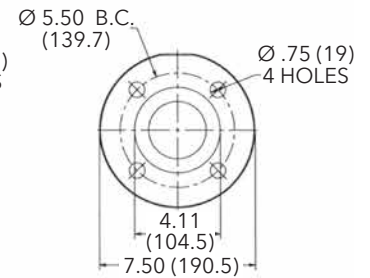

316SS
2 1/2" Class 150 R.F.

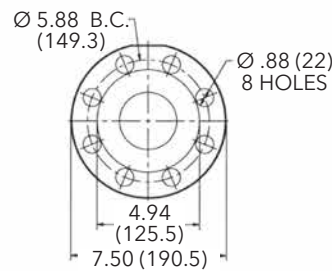

Cast Iron
2 1/2" Class 250 R.F.

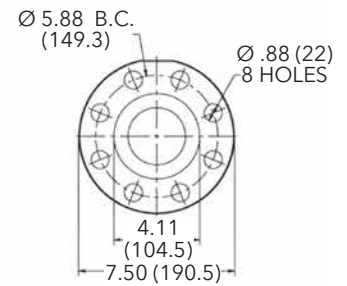

316SS
2 1/2" Class 300 R.F.

33SV SERIES – 60Hz, 3500 RPM ODP/TEFC Enclosures

Pump Type Stages	Motor				Dimensions (in)											Weight (lbs.)									
	HP	NEMA Frame			L1	L2					M (Ref.)	D1 (max.)				D2	Pump Only	Motor				Pump/Motor			
		ODP 1Ø	TEFC 1Ø	ODP 3Ø		TEFC 3Ø	ODP 1Ø	TEFC 1Ø	ODP 3Ø	TEFC 3Ø		ODP 1Ø	TEFC 1Ø	ODP 3Ø	TEFC 3Ø			ODP 1Ø	TEFC 1Ø	ODP 3Ø	TEFC 3Ø	ODP 1Ø	TEFC 1Ø	ODP 3Ø	TEFC 3Ø
33SV-1	5	184TC		182TC	184TC	20.62	13.93	15.43	12.55	13.93	6.87	8.88	8.86	9.02	8.86	5.51	132	81	92	62	69	213	224	194	201
33SV-2/2	7.5	213TC		184TC	23.58	13.88	15.53	13.93	15.43	8.05	8.89	10.62	8.88	8.86	5.51	143	100	120	75	85	243	263	218	228	
33SV-2/1	10	215TC	213TC	215TC	23.58	16.63	16.68	15.55	15.51	8.77	10.62	10.18	10.18	10.28	4.13	143	132	145	107	122	275	288	250	265	
33SV-2					23.58	16.63	16.68	15.55	15.51	8.77	10.62	10.18	10.18	10.28	4.13	143	132	145	107	122	275	288	250	265	
33SV-3/2	15	-	-	215TC	254TC	26.54	-	-	15.55	16.57	9.22	-	-	10.18	10.28	4.72	152	-	-	125	195	-	-	277	347
33SV-3/1						26.54	-	-	15.55	16.57	9.22	-	-	10.18	10.28	4.72	152	-	-	125	195	-	-	277	347
33SV-3						26.54	-	-	15.55	16.57	9.22	-	-	10.18	10.28	4.72	152	-	-	125	195	-	-	277	347
33SV-4/2	20	-	-	254TC	256TC	29.50	-	-	16.66	20.08	9.50	-	-	10.18	13.13	5.51	161	-	-	144	285	-	-	305	446
33SV-4/1						29.50	-	-	16.66	20.08	9.50	-	-	10.18	13.13	5.51	161	-	-	144	285	-	-	305	446
33SV-4						29.50	-	-	16.66	20.08	9.50	-	-	10.18	13.13	5.51	161	-	-	144	285	-	-	305	446
33SV-5/2	25	-	-	254TC	284TC	32.44	-	-	21.44	19.54	12.94	-	-	11.63	12.94	5.51	172	-	-	185	283	-	-	357	455
33SV-5/1						32.44	-	-	21.44	19.54	12.94	-	-	11.63	12.94	5.51	172	-	-	185	283	-	-	357	455
33SV-5						32.44	-	-	21.44	19.54	12.94	-	-	11.63	12.94	5.51	186	-	-	185	283	-	-	371	469
33SV-6/2	30	-	-	284TC	286TC	35.40	-	-	21.75	19.54	12.21	-	-	13.25	12.94	5.51	194	-	-	296	382	-	-	490	576
33SV-6/1						35.40	-	-	21.75	19.54	12.21	-	-	13.25	12.94	5.51	194	-	-	296	382	-	-	490	576
33SV-6						35.40	-	-	21.75	19.54	12.21	-	-	13.25	12.94	5.51	194	-	-	296	382	-	-	490	576
33SV-7/2	40	-	-	286TC	286TC	38.55	-	-	21.75	23.18	13.11	-	-	13.25	15.56	5.51	204	-	-	315	446	-	-	519	650
33SV-7/1						38.55	-	-	21.75	23.18	13.11	-	-	13.25	15.56	5.51	204	-	-	315	446	-	-	519	650
33SV-7						38.55	-	-	21.75	23.18	13.11	-	-	13.25	15.56	5.51	204	-	-	315	446	-	-	519	650
33SV-8/2	40	-	-	286TC	286TC	41.30	-	-	21.75	23.18	13.11	-	-	13.25	15.56	5.51	221	-	-	315	446	-	-	536	667
33SV-8/1						41.30	-	-	21.75	23.18	13.11	-	-	13.25	15.56	5.51	229	-	-	315	446	-	-	544	675
33SV-8						41.30	-	-	21.75	23.18	13.11	-	-	13.25	15.56	5.51	229	-	-	315	446	-	-	544	675
33SV-9/2	50	-	-	324TSC	326TSC	44.25	-	-	22.75	23.19	12.21	-	-	13.03	15.69	5.51	238	-	-	320	450	-	-	558	688
33SV-9/1						44.25	-	-	22.75	23.19	12.21	-	-	13.03	15.69	5.51	238	-	-	320	450	-	-	558	688
33SV-9						44.25	-	-	22.75	23.19	12.21	-	-	13.03	15.69	5.51	238	-	-	320	450	-	-	558	688
33SV-10/2	50	-	-	324TSC	326TSC	47.20	-	-	22.75	23.19	12.21	-	-	13.03	15.69	5.51	249	-	-	320	450	-	-	569	699
33SV-10/1						47.20	-	-	22.75	23.19	12.21	-	-	13.03	15.69	5.51	249	-	-	320	450	-	-	569	699
33SV-10						47.20	-	-	22.75	23.19	12.21	-	-	13.03	15.69	5.51	249	-	-	320	450	-	-	569	699

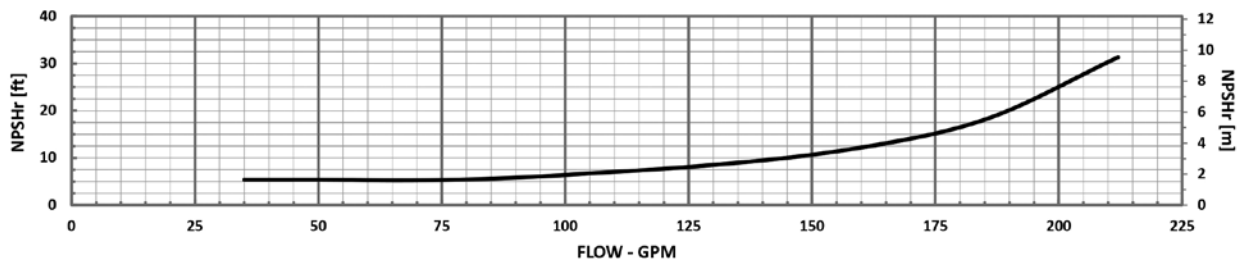
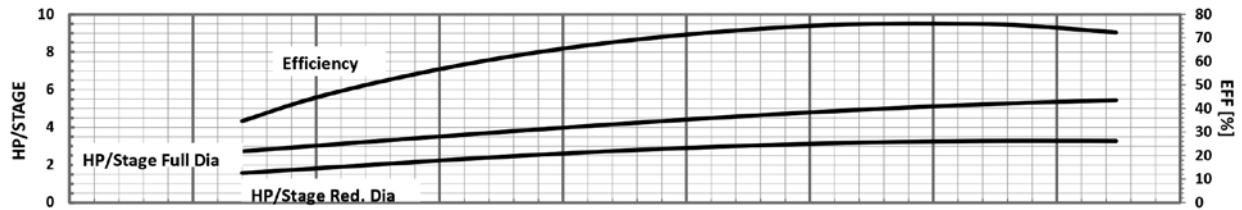
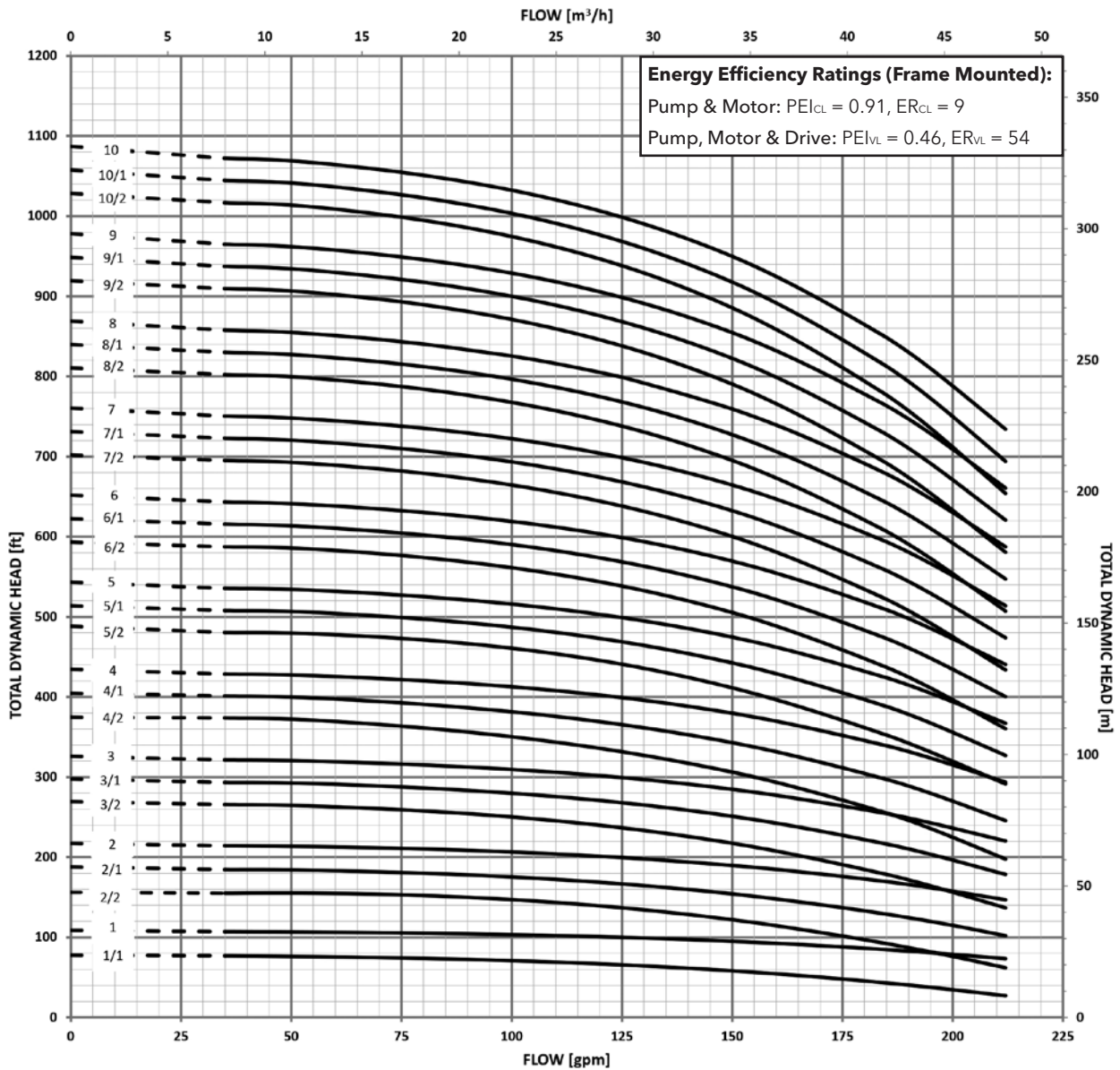

MINIMUM FLOW RATE: 35 GPM [8 m³/hr]

Commercial Water

Dimensions and Weights

46SV Series 3500 RPM

60 Hz

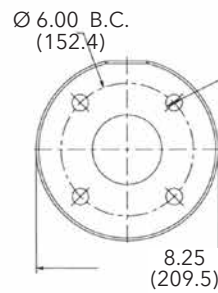
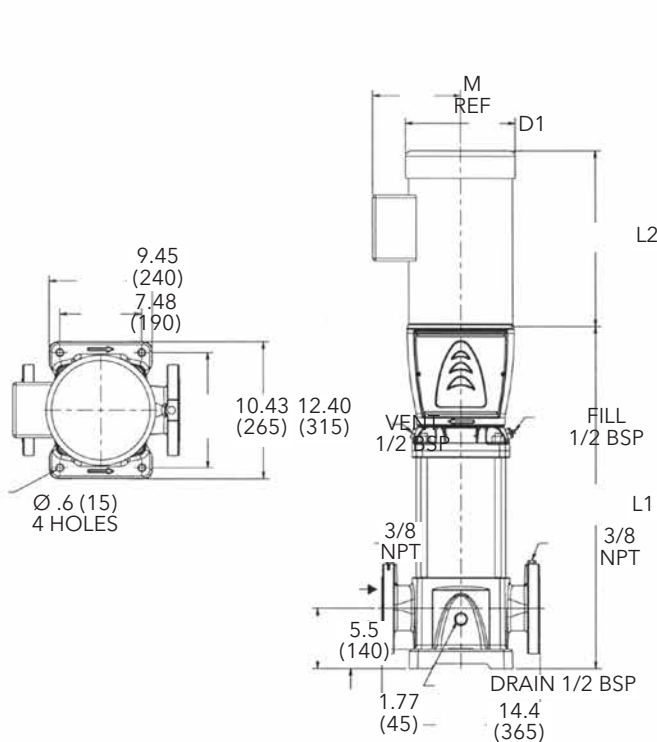

**Cast Iron
3" Class 125 F.F.**

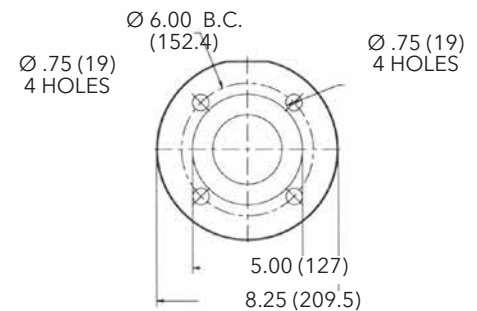

**316SS
3" Class 150 R.F.**

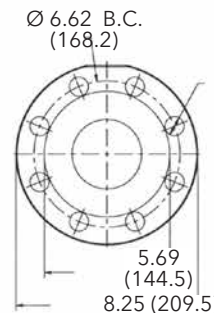

**Cast Iron
3" Class 250 R.F.**

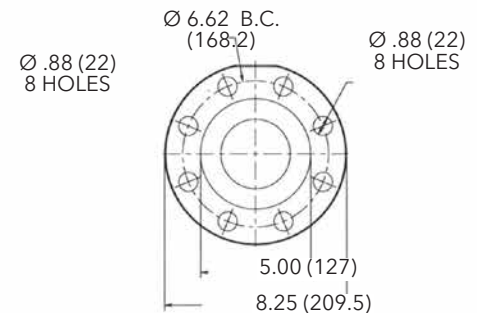

**316SS
3" Class 300 R.F.**

All dimensions are in inches (mm).

46SV SERIES – 60Hz, 3500 RPM ODP/TEFC Enclosures

Pump Type Stages	Motor				Dimensions (in)										Weight (lbs.)										
	HP	NEMA Frame			L1	L2				M (Ref.)	D1 (max.)				D2	Pump Only	Motor				Pump/Motor				
		ODP 1Ø	TEFC 1Ø	ODP 3Ø		TEFC 3Ø	ODP 1Ø	TEFC 1Ø	ODP 3Ø		TEFC 3Ø	ODP 1Ø	TEFC 1Ø	ODP 3Ø			TEFC 3Ø	ODP 1Ø	TEFC 1Ø	ODP 3Ø	TEFC 3Ø	ODP 1Ø	TEFC 1Ø	ODP 3Ø	TEFC 3Ø
46SV-1	10	-	-	213TC	215TC	22.19	16.63	16.68	15.55	15.51	8.77	10.62	10.18	10.18	10.28	4.13	174	132	145	107	122	306	319	281	296
46SV-2/2	15	-	-	215TC	254TC	25.19	-	-	15.55	16.57	9.22	-	-	10.18	10.28	4.72	158	-	-	125	195	-	-	283	353
46SV-2/1		-	-			25.19	-	-	15.55	16.57	9.22	-	-	10.18	10.28	4.72	158	-	-	125	195	-	-	283	353
46SV-2		-	-			25.19	-	-	15.55	16.57	9.22	-	-	10.18	10.28	4.72	158	-	-	125	195	-	-	283	353
46SV-3/2	20	-	-	254TC	256TC	28.12	-	-	16.66	20.08	9.50	-	-	10.18	13.13	5.51	169	-	-	144	285	-	-	313	454
46SV-3/1		-	-			28.12	-	-	16.66	20.08	9.50	-	-	10.18	13.13	5.51	169	-	-	144	285	-	-	313	454
46SV-3		-	-			29.63	-	-	21.44	19.54	12.94	-	-	11.63	12.94	5.51	183	-	-	185	283	-	-	368	466
46SV-4/2	30	-	-	284TC	286TC	32.63	-	-	21.75	19.54	12.21	-	-	13.25	12.94	5.51	192	-	-	296	382	-	-	488	574
46SV-4/1		-	-			32.63	-	-	21.75	19.54	12.21	-	-	13.25	12.94	5.51	192	-	-	296	382	-	-	488	574
46SV-4		-	-			32.63	-	-	21.75	19.54	12.21	-	-	13.25	12.94	5.51	192	-	-	296	382	-	-	488	574
46SV-5/2	40	-	-	286TC	286TC	35.56	-	-	21.75	23.18	13.11	-	-	13.25	15.56	5.51	199	-	-	315	446	-	-	514	645
46SV-5/1		-	-			35.56	-	-	21.75	23.18	13.11	-	-	13.25	15.56	5.51	199	-	-	315	446	-	-	514	645
46SV-5		-	-			35.56	-	-	21.75	23.18	13.11	-	-	13.25	15.56	5.51	199	-	-	315	446	-	-	514	645
46SV-6/2	50	-	-	324TSC	326TSC	38.50	-	-	21.75	23.18	13.11	-	-	13.25	15.56	5.51	208	-	-	315	446	-	-	523	654
46SV-6/1		-	-			38.00	-	-	22.75	23.19	12.21	-	-	13.03	15.69	5.51	216	-	-	320	450	-	-	536	666
46SV-6		-	-			38.00	-	-	22.75	23.19	12.21	-	-	13.03	15.69	5.51	216	-	-	320	450	-	-	536	666
46SV-7/2	60	-	-	324TSC	326TSC	40.94	-	-	22.75	23.19	12.21	-	-	13.03	15.69	5.51	233	-	-	320	450	-	-	553	683
46SV-7/1		-	-			40.94	-	-	22.75	23.19	12.21	-	-	13.03	15.69	5.51	233	-	-	320	450	-	-	553	683
46SV-7		-	-			40.94	-	-	22.75	30.69	14.95	-	-	13.03	19.25	5.51	233	-	-	372	689	-	-	605	922
46SV-8/2	75	-	-	364TSC	365TSC	43.94	-	-	22.75	30.69	14.95	-	-	13.03	19.25	5.51	242	-	-	372	689	-	-	614	931
46SV-8/1		-	-			43.94	-	-	22.75	30.69	14.95	-	-	13.03	19.25	5.51	242	-	-	372	689	-	-	614	931
46SV-8		-	-			43.94	-	-	22.75	30.69	14.95	-	-	13.03	19.25	5.51	242	-	-	372	689	-	-	614	931
46SV-9/2	75	-	-	364TSC	365TSC	46.88	-	-	24.38	30.69	14.95	-	-	15.13	19.25	5.51	253	-	-	447	747	-	-	700	1000
46SV-9/1		-	-			46.88	-	-	24.38	30.69	14.95	-	-	15.13	19.25	5.51	253	-	-	447	747	-	-	700	1000
46SV-9		-	-			46.88	-	-	24.38	30.69	14.95	-	-	15.13	19.25	5.51	253	-	-	447	747	-	-	700	1000
46SV-10/2	75	-	-	364TSC	365TSC	49.81	-	-	24.38	30.69	14.95	-	-	15.13	19.25	5.51	264	-	-	447	747	-	-	711	1011

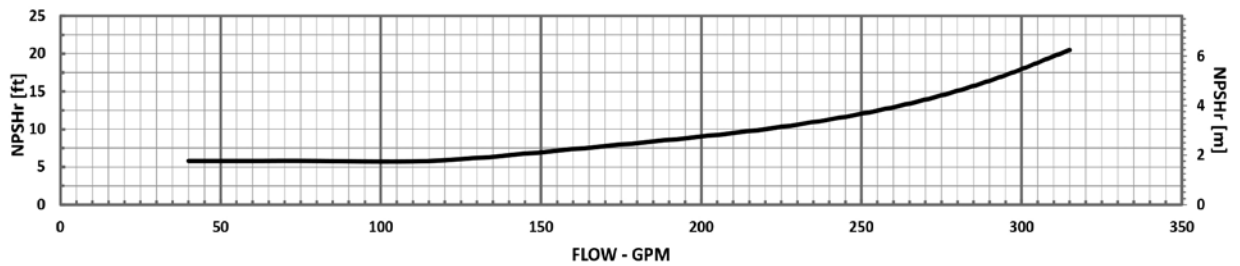
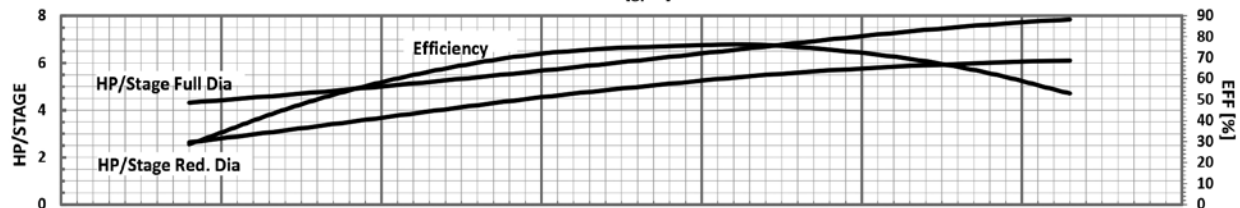
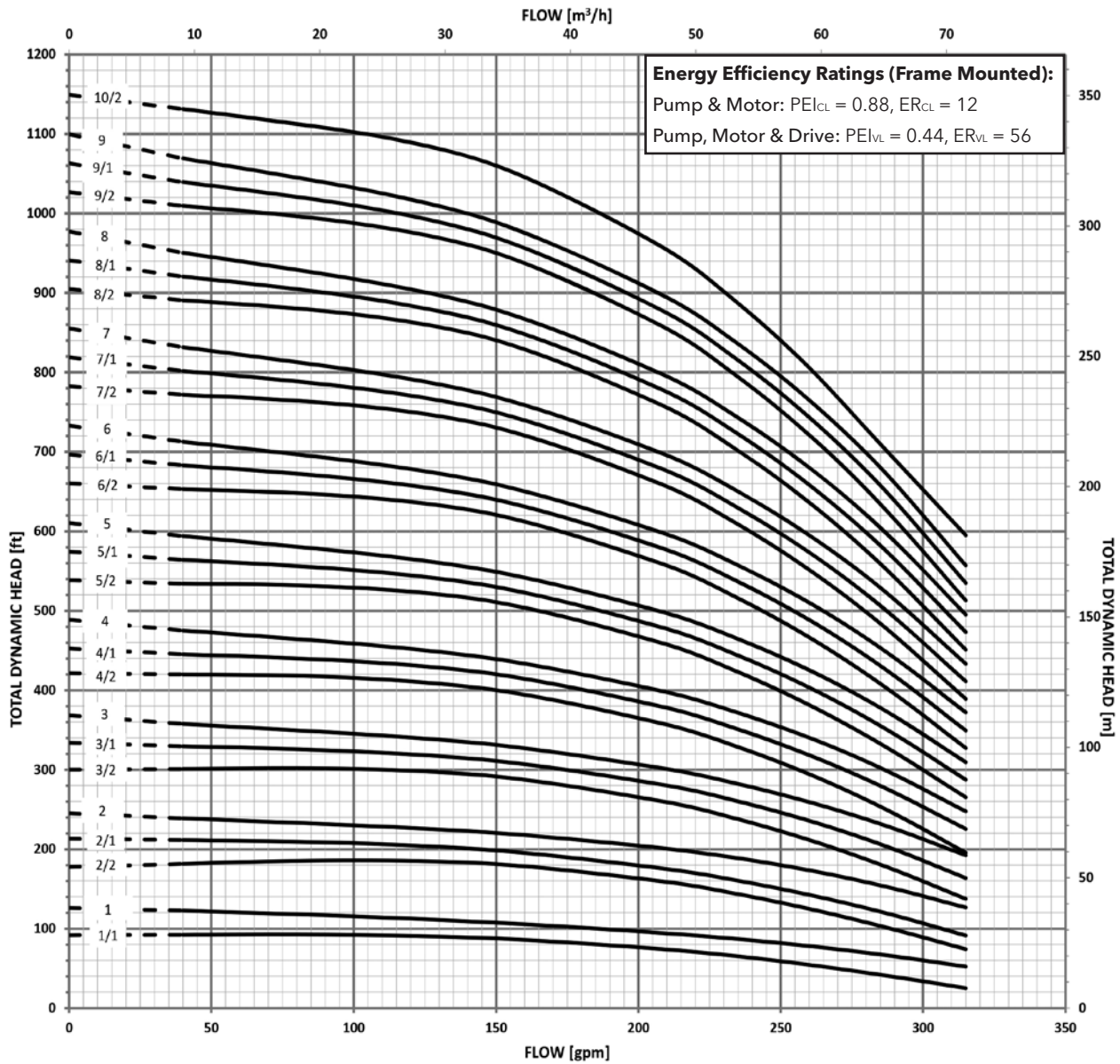

MINIMUM FLOW RATE: 40 GPM [9 m³/hr]

Commercial Water

Dimensions and Weights

66SV Series 3500 RPM

60 Hz

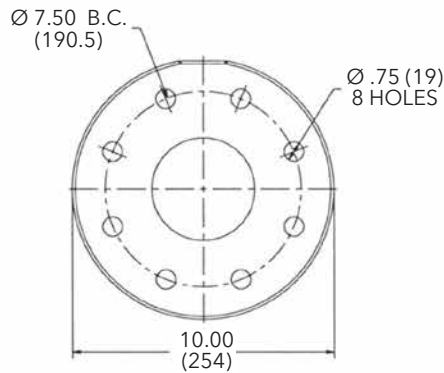
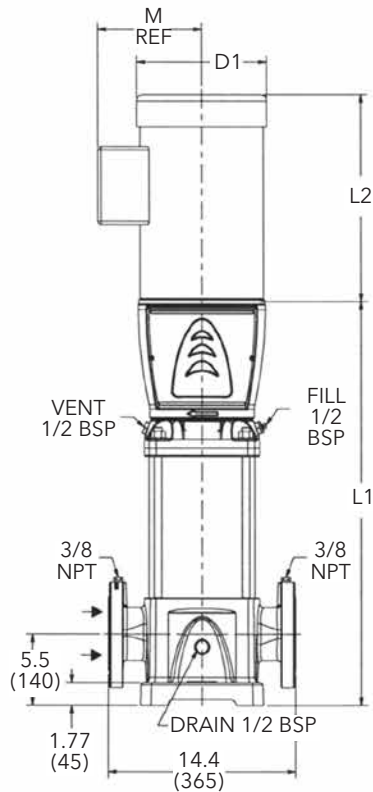
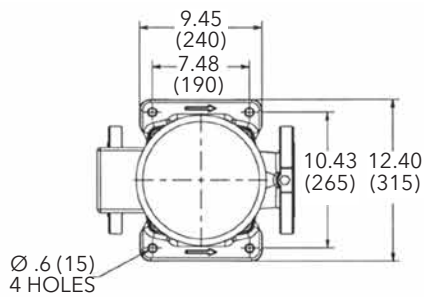

**Cast Iron
4" Class 125 F.F.**

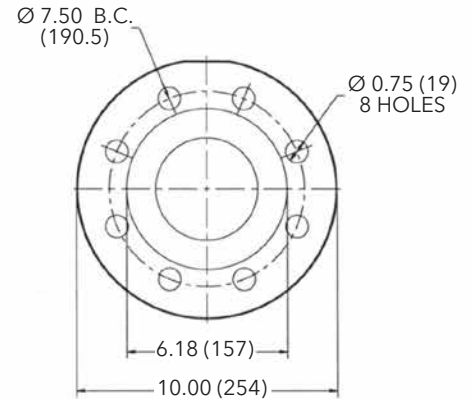

**316SS
4" Class 150 R.F.**

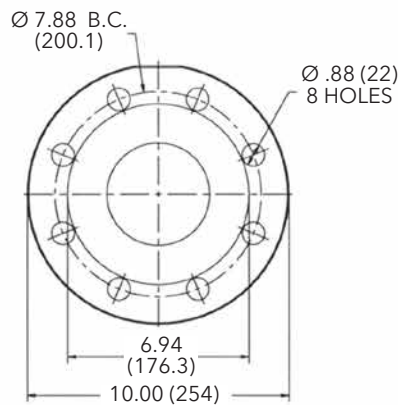

**Cast Iron
4" Class 250 R.F.**

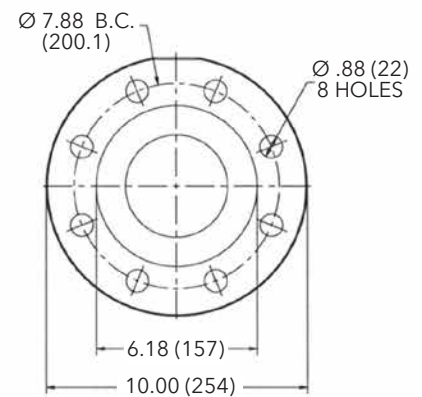

**316SS
4" Class 300 R.F.**

All dimensions are in inches (mm).

66SV SERIES – 60Hz, 3500 RPM ODP/TEFC Enclosures

Pump Type Stages	Motor				Dimensions (in)										Weight (lbs.)										
	HP	NEMA Frame			L1	L2				M (Ref.)	D1 (max.)				D2	Pump Only	Motor				Pump/Motor				
		ODP 1Ø	TEFC 1Ø	ODP 3Ø		TEFC 3Ø	ODP 1Ø	TEFC 1Ø	ODP 3Ø		TEFC 3Ø	ODP 1Ø	TEFC 1Ø	ODP 3Ø			TEFC 3Ø	ODP 1Ø	TEFC 1Ø	ODP 3Ø	TEFC 3Ø	ODP 1Ø	TEFC 1Ø	ODP 3Ø	TEFC 3Ø
66SV-1	15	-	-	215TC	254TC	23.19	-	-	15.56	16.56	9.25	-	-	10.19	10.31	5.51	185	-	-	128	250	-	-	313	435
66SV-2/2	20	-	-	254TC	256TC	26.75	-	-	15.56	16.56	9.25	-	-	10.19	10.31	5.51	196	-	-	220	280	-	-	416	476
66SV-2/1		-	-			26.75	-	-	15.56	16.56	9.25	-	-	10.19	10.31	5.51	196	-	-	220	280	-	-	416	476
66SV-2	25	-	-	256TC	284TC	28.31	-	-	18.00	23.38	13.12	-	-	11.63	15.31	5.51	210	-	-	240	420	-	-	450	630
66SV-3/2	30	-	-	284TC	284TC	31.81	-	-	20.12	23.38	13.12	-	-	13.25	15.31	5.51	223	-	-	325	445	-	-	548	668
66SV-3/1		-	-			31.81	-	-	20.12	23.38	13.12	-	-	13.25	15.31	5.51	223	-	-	325	445	-	-	548	668
66SV-3		-	-			31.81	-	-	20.12	23.38	13.12	-	-	13.25	15.31	5.51	223	-	-	328	448	-	-	551	671
66SV-4/2	40	-	-	326TSC	326TSC	35.38	-	-	20.12	23.38	13.12	-	-	13.25	15.31	5.51	234	-	-	328	448	-	-	562	682
66SV-4/1		-	-			34.88	-	-	22.50	23.38	13.12	-	-	13.25	15.31	5.51	242	-	-	382	592	-	-	624	834
66SV-4		-	-			34.88	-	-	22.50	23.38	13.12	-	-	13.25	15.31	5.51	242	-	-	382	592	-	-	624	834
66SV-5/2	50	-	-	326TSC	364TSC	38.44	-	-	22.50	23.38	13.12	-	-	13.25	15.31	5.51	252	-	-	382	592	-	-	634	844
66SV-5/1		-	-			38.44	-	-	22.50	27.22	14.96	-	-	13.25	19.00	5.51	252	-	-	474	736	-	-	726	988
66SV-5		-	-			38.44	-	-	22.50	27.22	14.96	-	-	13.25	19.00	5.51	252	-	-	474	736	-	-	726	988
66SV-6/2	60	-	-	326TSC	364TSC	41.94	-	-	24.12	27.22	14.96	-	-	15.12	19.00	5.51	266	-	-	500	762	-	-	766	1028
66SV-6/1		-	-			41.94	-	-	24.12	27.22	14.96	-	-	15.12	19.00	5.51	266	-	-	500	762	-	-	766	1028
66SV-6		-	-			41.94	-	-	24.12	27.22	14.96	-	-	15.12	19.00	5.51	266	-	-	500	762	-	-	766	1028

Performance Curve

66SV 3500 RPM

60 Hz

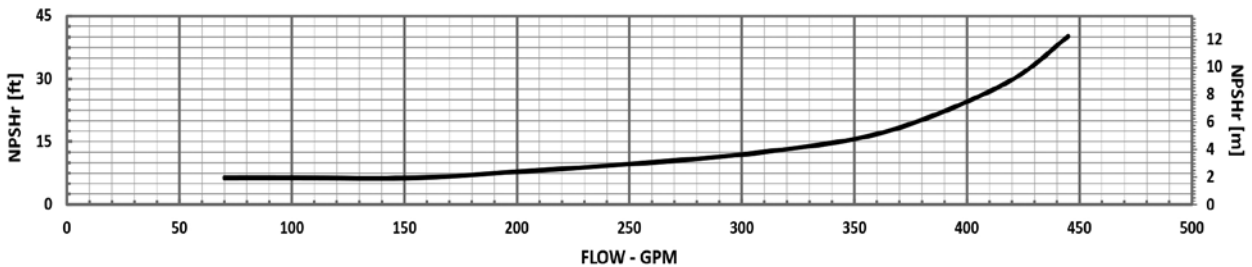
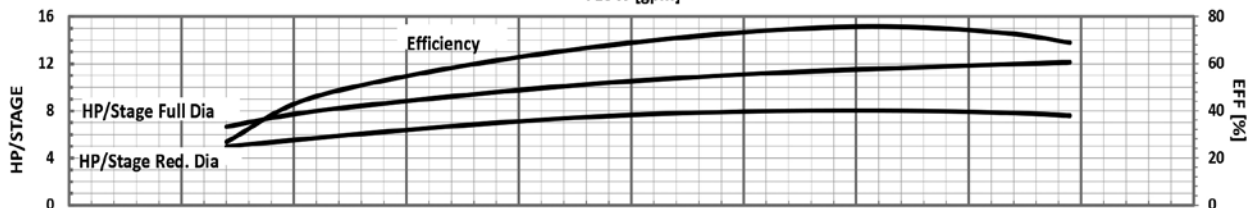
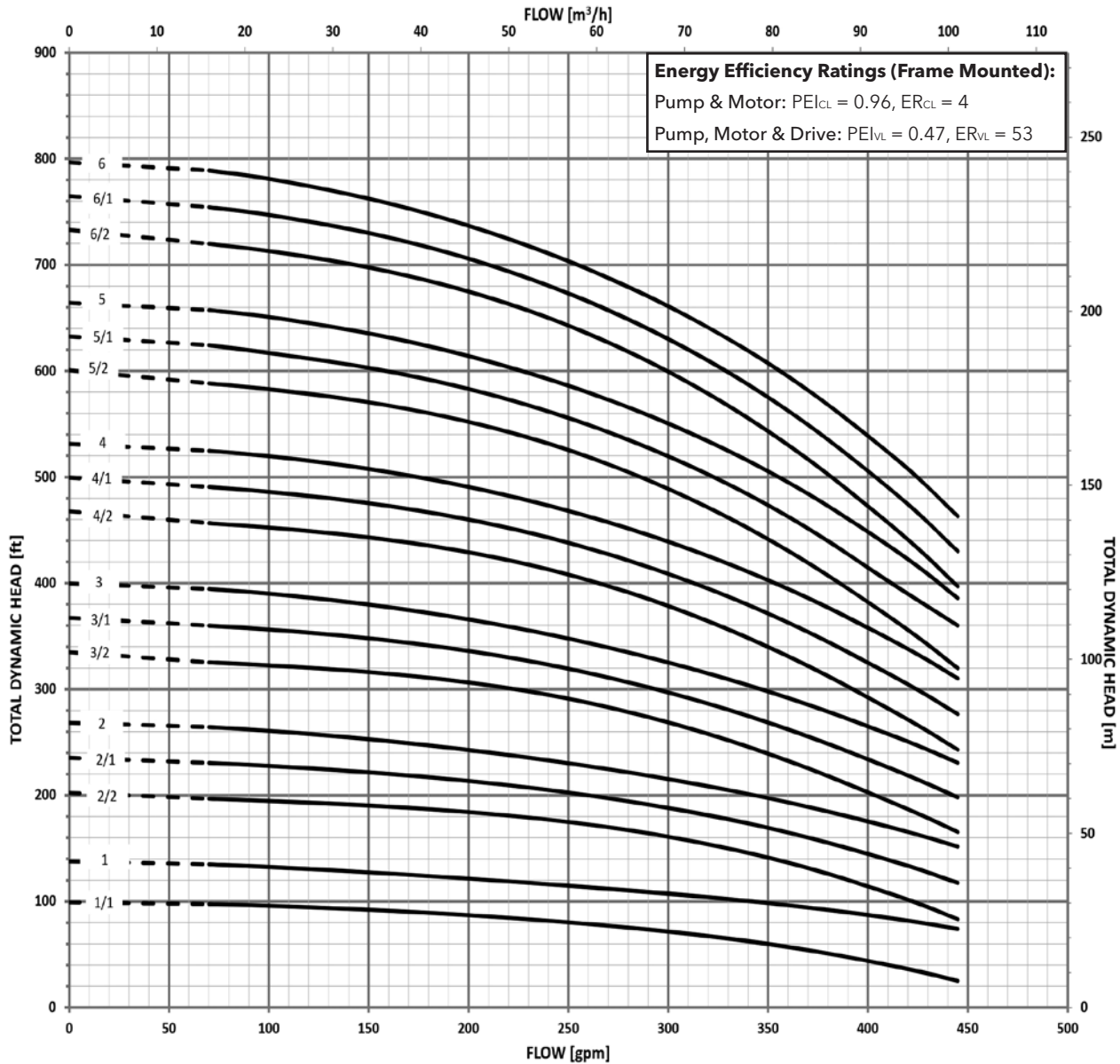

MINIMUM FLOW RATE: 70 GPM [16 m³/hr]

Commercial Water

Dimensions and Weights

92SV Series 3500 RPM

60 Hz

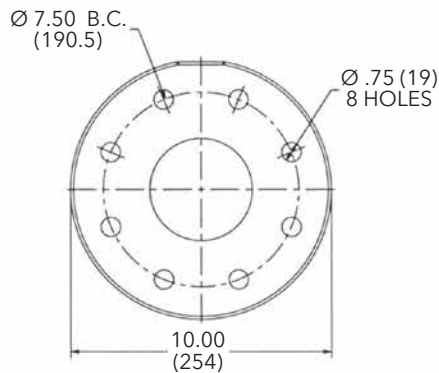
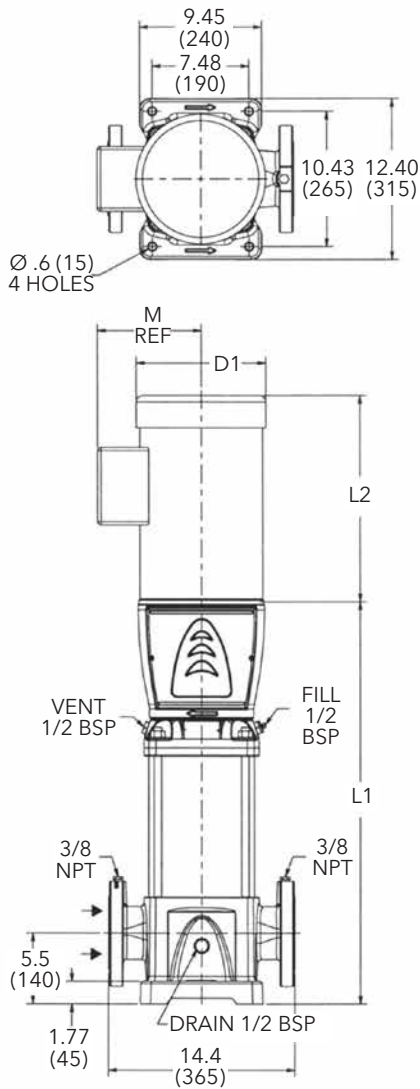

Cast Iron
4" Class 125 F.F.

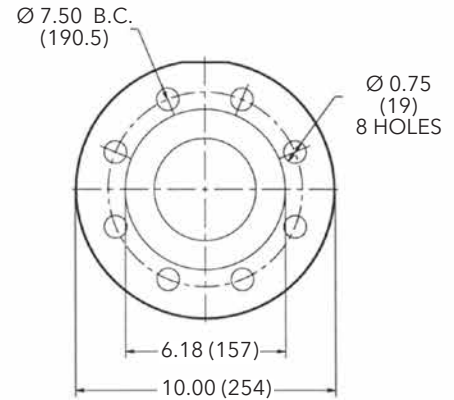

316SS
4" Class 150 R.F.

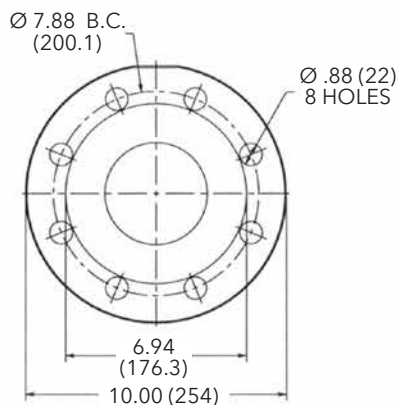

Cast Iron
4" Class 250 R.F.

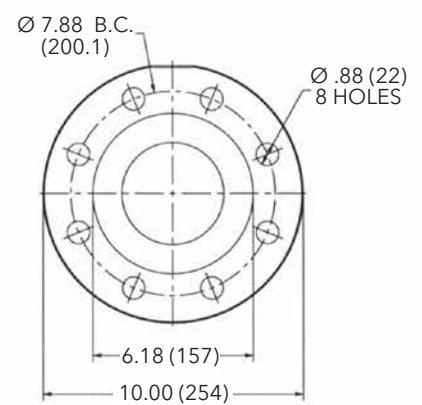

316SS
4" Class 300 R.F.

All dimensions are in inches (mm).

92SV SERIES – 60Hz, 3500 RPM ODP/TEFC Enclosures

Pump Type Stages	Motor				Dimensions (in)											Weight (lbs.)									
	HP	NEMA Frame			L1	L2				M (Ref.)	D1 (max.)				D2	Pump Only	Motor				Pump/Motor				
		ODP 1Ø	TEFC 1Ø	ODP 3Ø		TEFC 3Ø	ODP 1Ø	TEFC 1Ø	ODP 3Ø		TEFC 3Ø	ODP 1Ø	TEFC 1Ø	ODP 3Ø			TEFC 3Ø	ODP 1Ø	TEFC 1Ø	ODP 3Ø	TEFC 3Ø				
92SV-1	15	-	-	215TC	254TC	23.19	-	-	15.56	16.56	9.25	-	-	10.19	10.31	5.51	185	-	-	128	250	-	-	313	435
92SV-2/2	25	-	-	256TC	284TC	28.31	-	-	18.00	23.38	13.12	-	-	11.63	15.31	5.51	210	-	-	240	420	-	-	450	630
92SV-2/1	30	-	-	284TC	284TC	28.31	-	-	20.12	23.38	13.12	-	-	13.25	15.31	5.51	210	-	-	325	445	-	-	535	655
92SV-2																									
92SV-3/2	40	-	-	284TC	284TC	31.18	-	-	20.12	23.38	13.12	-	-	13.25	15.31	5.51	223	-	-	328	448	-	-	551	671
92SV-3/1																									
92SV-3	50	-	-	326TSC	326TSC	31.28	-	-	22.50	23.38	13.12	-	-	13.25	15.31	5.51	231	-	-	382	592	-	-	613	823
92SV-4/2	60	-	-	326TSC	364TSC	34.88	-	-	22.50	27.22	13.12	-	-	13.25	19.00	5.51	242	-	-	474	736	-	-	716	978
92SV-4/1																									
92SV-4																									
92SV-5/2	75	-	-	365TSC	365TSC	38.44	-	-	24.12	27.22	14.96	-	-	15.12	19.00	5.51	252	-	-	500	762	-	-	752	1014
92SV-5/1																									

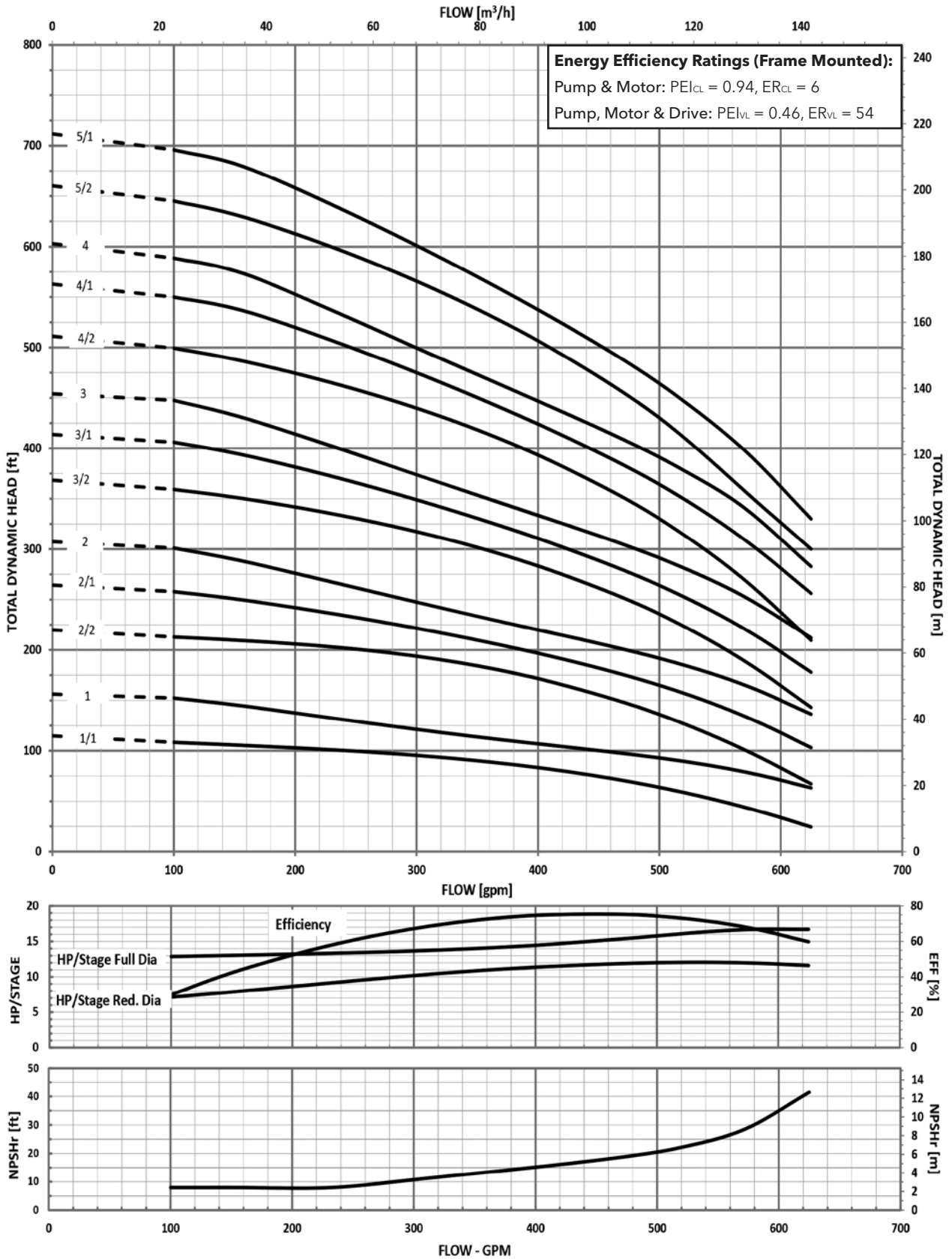

MINIMUM FLOW RATE: 100 GPM [23 m³/hr]

Commercial Water

Dimensions and Weights

125SV Series 3500 RPM

60 Hz

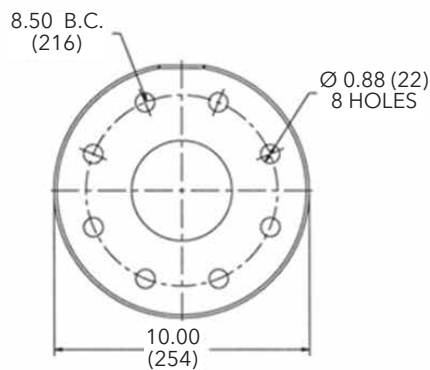
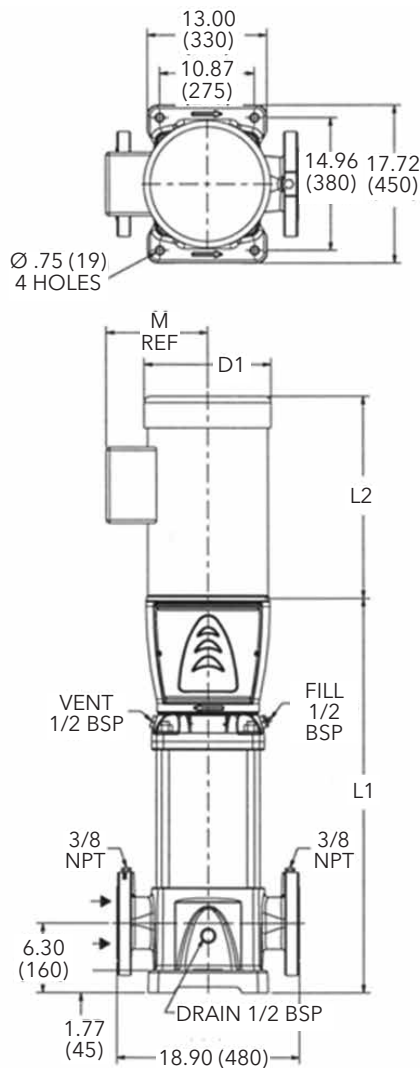

**Cast Iron
5" Class 125 F.F.**

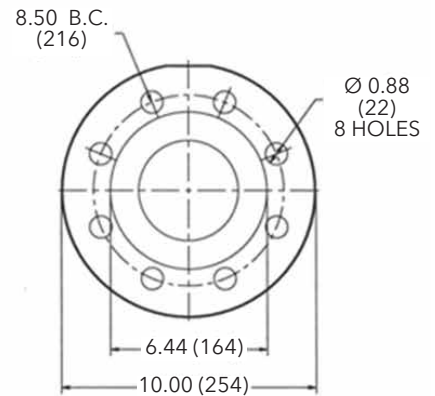

**316SS
5" Class 150 R.F.**

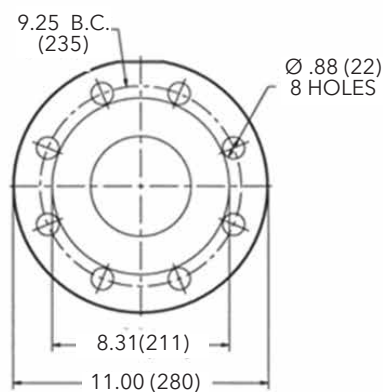

**Cast Iron
5" Class 250 R.F.**

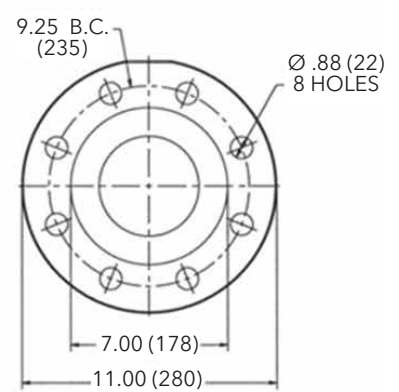

**316SS
5" Class 300 R.F.**

All dimensions are in inches (mm).

125SV SERIES – 60Hz, 3500 RPM ODP/TEFC Enclosures

Pump Type	HP	Motor		Dimensions (in)															Weight (lbs.)										
		NEMA Frame		L2				L3	L4	L5	L6	M (Ref.)	D1 (max.)				D2	Motor				Pump/Motor							
		ODP 1Ø	TEFC 1Ø	ODP 3Ø	TEFC 3Ø	ODP 1Ø	TEFC 1Ø						ODP 3Ø	TEFC 3Ø	ODP 1Ø	TEFC 1Ø		ODP 3Ø	TEFC 3Ø	ODP 1Ø	TEFC 1Ø	ODP 3Ø	TEFC 3Ø	ODP 1Ø	TEFC 1Ø	ODP 3Ø	TEFC 3Ø		
125SV10C	15	-	-	215TC	254TC	27.30	-	-	15.55	16.57	-	-	-	-	9.22	-	-	10.18	10.28	4.72	256	-	-	125	195	-	-	381	451
125SV20C	30	-	-	284TC	286TC	34.57	-	-	21.75	19.54	-	-	-	12.21	-	-	13.25	12.94	5.51	289	-	-	296	382	-	-	585	671	
125SV33A	40	-	-	286TC	286TC	40.47	-	-	21.75	23.18	-	-	-	13.11	-	-	13.25	15.56	5.51	315	-	-	315	446	-	-	630	761	
125SV43B	50	-	-	324TSC	326TSC	46.40	-	-	22.75	23.19	-	-	-	12.21	-	-	13.03	15.69	5.51	355	-	-	320	450	-	-	675	805	
125SV55B	60	-	-	324TSC	326TSC	52.30	-	-	22.75	30.69	-	-	-	14.95	-	-	13.03	19.25	5.51	379	-	-	372	689	-	-	751	1068	
125SV50C	75	-	-	364TSC	365TSC	52.28	-	-	24.38	30.69	-	-	-	14.95	-	-	15.13	19.25	5.51	379	-	-	447	747	-	-	826	1126	

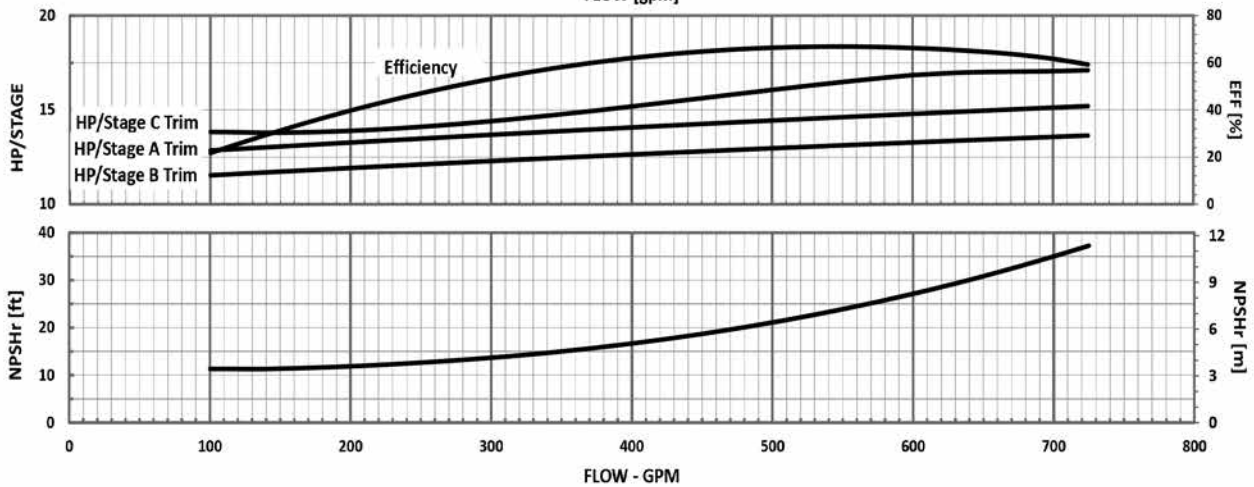
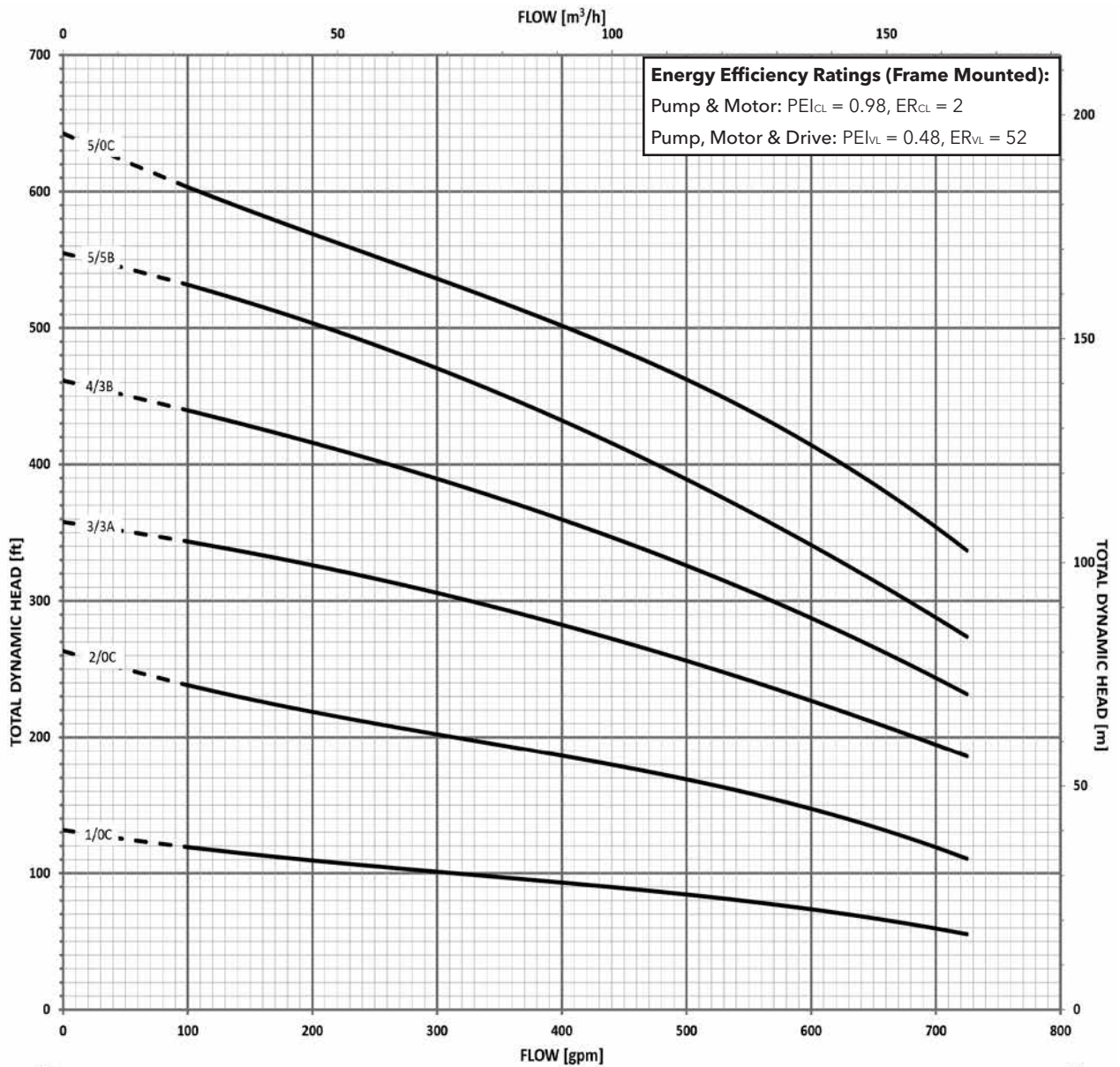

MINIMUM FLOW RATE: 100 GPM [20 m³/hr]

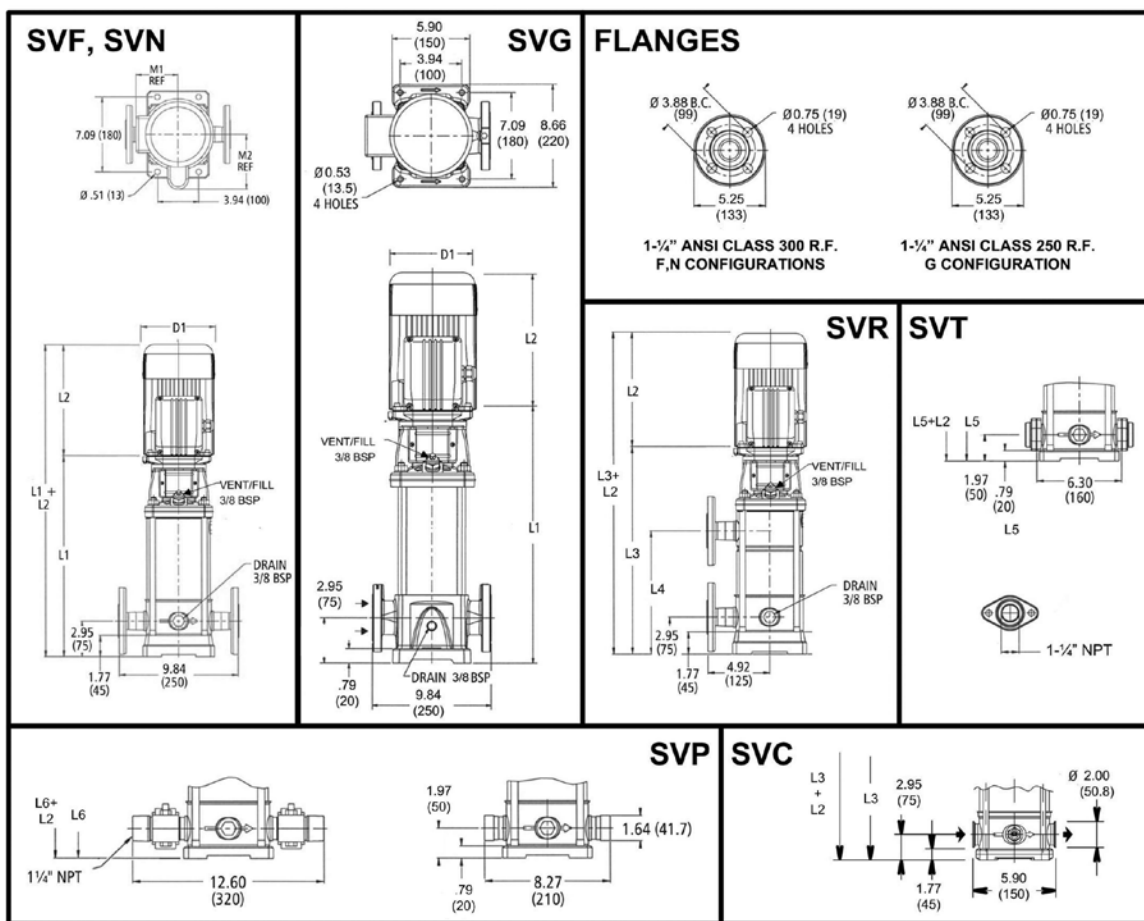

1SV SERIES – 60Hz, 1750 RPM ODP/TEFC Enclosures

Pump Type Stages	Motor				Dimensions (in)													Weight (lbs.)										
	HP	NEMA Frame				L2										D1 (max.)			D2	Pump Only	Motor				Pump/Motor			
		ODP 1Ø	TEFC 1Ø	ODP 3Ø	TEFC 3Ø	L1	ODP 1Ø	TEFC 1Ø	ODP 3Ø	TEFC 3Ø	L3	L4	L5	L6	M (Ref.)	ODP 1Ø	TEFC 1Ø	ODP 3Ø			TEFC 3Ø	ODP 1Ø	TEFC 1Ø	ODP 3Ø	TEFC 3Ø	ODP 1Ø	TEFC 1Ø	ODP 3Ø
1SV-02	0.5	56C	13.27	9.16	9.29	9.16	9.29	-	-	12.29	12.29	5.19	6.19	6.19	6.19	4.13	25	21	21	19	19	46	46	44	44			
1SV-03			13.27	9.16	9.29	9.16	9.29	-	-	12.29	12.29	5.19	6.19	6.19	6.19	4.13	26	21	21	19	19	47	47	45	45			
1SV-04			14.06	9.16	9.29	9.16	9.29	-	-	13.07	13.07	5.19	6.19	6.19	6.19	4.13	27	21	21	19	19	48	48	46	46			
1SV-05			14.85	9.16	9.29	9.16	9.29	-	-	13.86	13.86	5.19	6.19	6.19	6.19	4.13	28	21	21	19	19	49	49	47	47			
1SV-06			15.63	9.16	9.29	9.16	9.29	-	-	14.65	14.65	5.19	6.19	6.19	6.19	4.13	28	21	21	19	19	49	49	47	47			
1SV-07			16.42	9.16	9.29	9.16	9.29	-	-	15.44	15.44	5.19	6.19	6.19	6.19	4.13	29	21	21	19	19	50	50	48	48			
1SV-08			17.21	9.16	9.29	9.16	9.29	17.21	8.94	16.22	16.22	5.19	6.19	6.19	6.19	4.13	30	21	21	19	19	51	51	49	49			
1SV-09			18.00	9.16	9.29	9.16	9.29	18.00	9.72	17.01	17.01	5.19	6.19	6.19	6.19	4.13	31	21	21	19	19	52	52	50	50			
1SV-10			18.78	9.16	9.29	9.16	9.29	18.78	10.51	17.80	17.80	5.19	6.19	6.19	6.19	4.13	32	21	21	19	19	53	53	51	51			
1SV-11			19.57	9.16	9.29	9.16	9.29	19.57	11.30	18.59	18.59	5.19	6.19	6.19	6.19	4.13	33	21	21	19	19	54	54	52	52			
1SV-12			20.36	9.16	9.29	9.16	9.29	20.36	12.09	19.37	19.37	5.19	6.19	6.19	6.19	4.13	34	21	21	19	19	55	55	53	53			
1SV-13			21.14	9.16	9.29	9.16	9.29	21.14	12.87	20.16	20.16	5.19	6.19	6.19	6.19	4.13	35	21	21	19	19	56	56	54	54			
1SV-14			21.93	9.16	9.29	9.16	9.29	21.93	13.66	20.95	20.95	5.19	6.19	6.19	6.19	4.13	36	21	21	19	19	57	57	55	55			
1SV-15			22.72	9.16	9.29	9.16	9.29	22.72	14.45	21.74	21.74	5.19	6.19	6.19	6.19	4.13	37	21	21	19	19	58	58	56	56			
1SV-16			23.51	9.16	9.29	9.16	9.29	23.51	15.24	22.52	22.52	5.19	6.19	6.19	6.19	4.13	38	21	21	19	19	59	59	57	57			
1SV-17			24.29	9.16	9.29	9.16	9.29	24.29	16.02	23.31	23.31	5.19	6.19	6.19	6.19	4.13	38	21	21	19	19	59	59	57	57			
1SV-18			25.08	9.16	9.29	9.16	9.29	25.08	16.81	24.10	24.10	5.19	6.19	6.19	6.19	4.13	39	21	21	19	19	60	60	58	58			
1SV-19			25.87	9.16	9.29	9.16	9.29	25.87	17.60	24.89	24.89	5.19	6.19	6.19	6.19	4.13	40	21	21	19	19	61	61	59	59			
1SV-20			26.66	9.16	9.29	9.16	9.29	26.66	18.39	25.67	25.67	5.19	6.19	6.19	6.19	4.13	41	21	21	19	19	62	62	60	60			
1SV-21			27.44	9.16	9.29	9.16	9.29	27.44	19.17	26.46	26.46	5.19	6.19	6.19	6.19	4.13	42	21	21	19	19	63	63	61	61			
1SV-22			28.23	9.16	9.29	9.16	9.29	28.23	19.96	27.25	27.25	5.19	6.19	6.19	6.19	4.13	43	21	21	19	19	64	64	62	62			
1SV-23			29.02	9.16	9.29	9.16	9.29	29.02	20.75	28.03	28.03	5.19	6.19	6.19	6.19	4.13	45	21	21	19	19	66	66	64	64			
1SV-24			29.81	9.16	9.29	9.16	9.29	29.81	21.54	28.82	28.82	5.19	6.19	6.19	6.19	4.13	46	21	21	19	19	67	67	65	65			
1SV-25			30.59	9.16	9.29	9.16	9.29	30.59	22.32	29.61	29.61	5.19	6.19	6.19	6.19	4.13	47	21	21	19	19	68	68	66	66			
1SV-26			31.38	9.16	9.29	9.16	9.29	31.38	23.11	30.40	30.40	5.19	6.19	6.19	6.19	4.13	47	21	21	19	19	68	68	66	66			
1SV-27			32.17	9.16	9.29	9.16	9.29	32.17	23.90	31.18	31.18	5.19	6.19	6.19	6.19	4.13	48	21	21	19	19	69	69	67	67			
1SV-28			32.96	9.16	9.29	9.16	9.29	32.96	24.68	31.97	31.97	5.19	6.19	6.19	6.19	4.13	49	21	21	19	19	70	70	68	68			
1SV-29			34.14	9.16	9.29	9.16	9.29	34.14	25.47	33.15	33.15	5.19	6.19	6.19	6.19	4.13	50	21	21	19	19	71	71	69	69			
1SV-30			34.53	9.16	9.29	9.16	9.29	34.53	26.26	33.55	33.55	5.19	6.19	6.19	6.19	4.13	51	21	21	19	19	72	72	70	70			

Performance Curve

1SV 1750 RPM

60 Hz

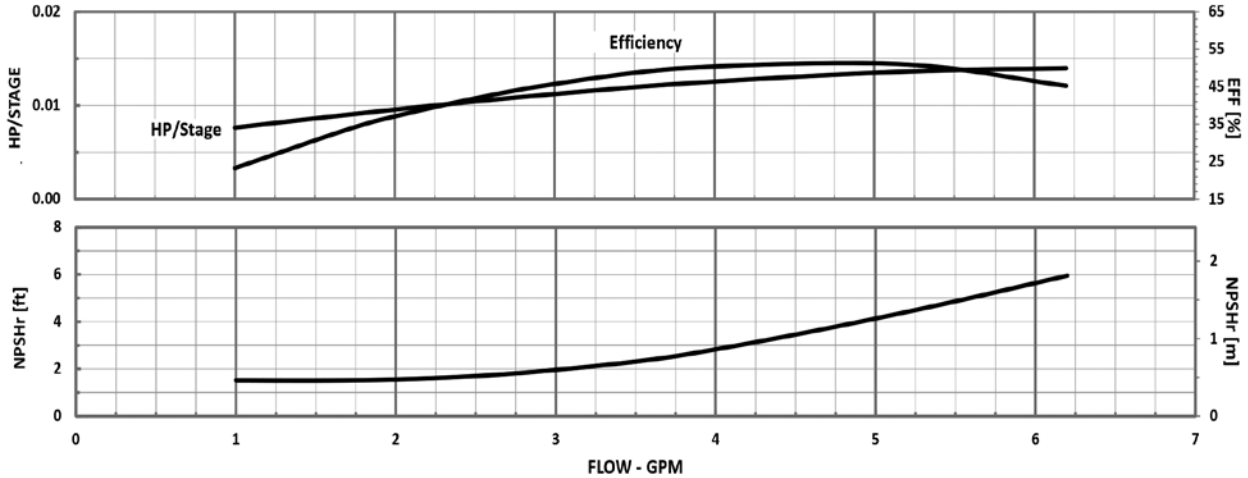
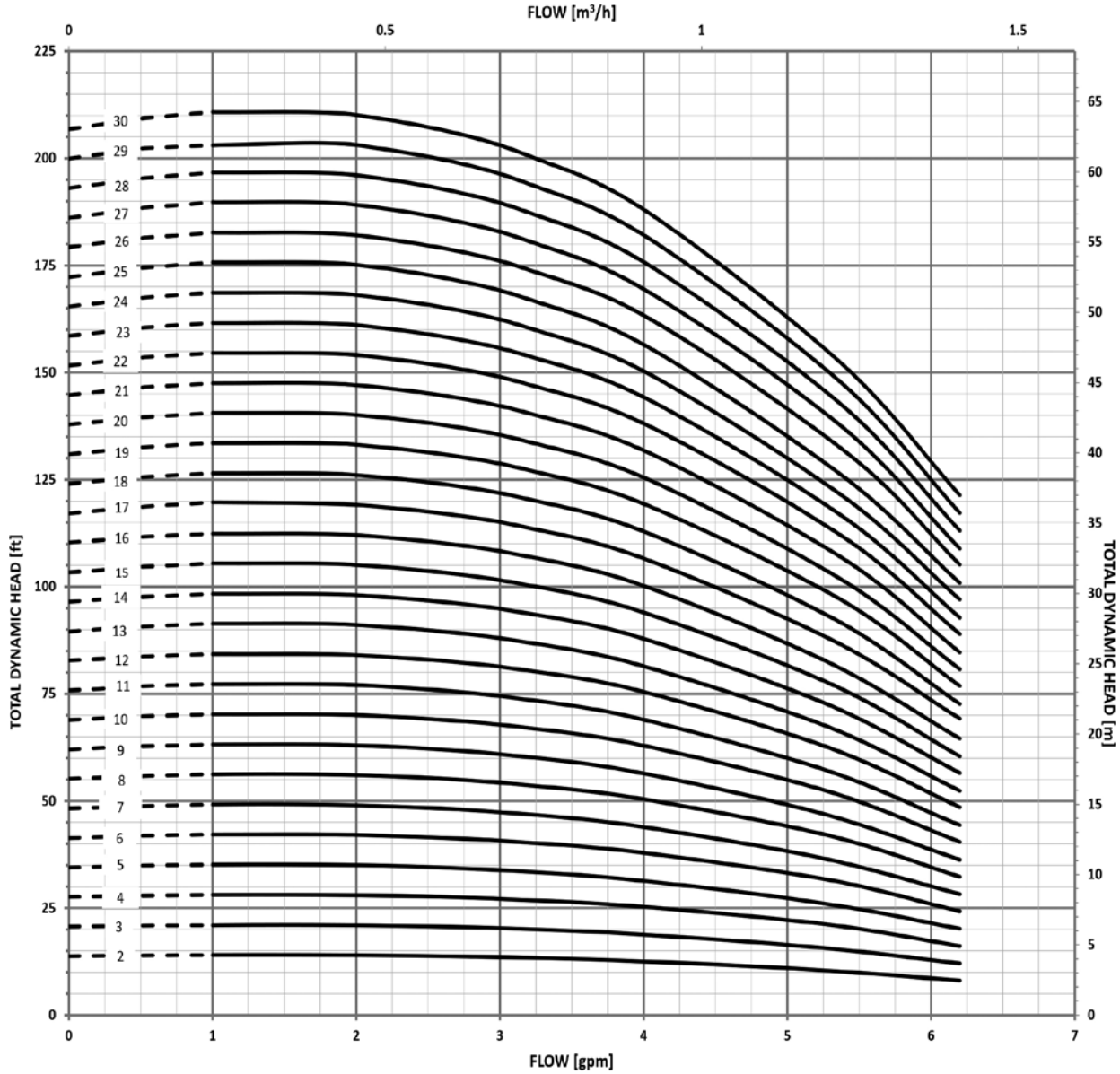

MINIMUM FLOW RATE: 1 GPM [.24 m³/hr]

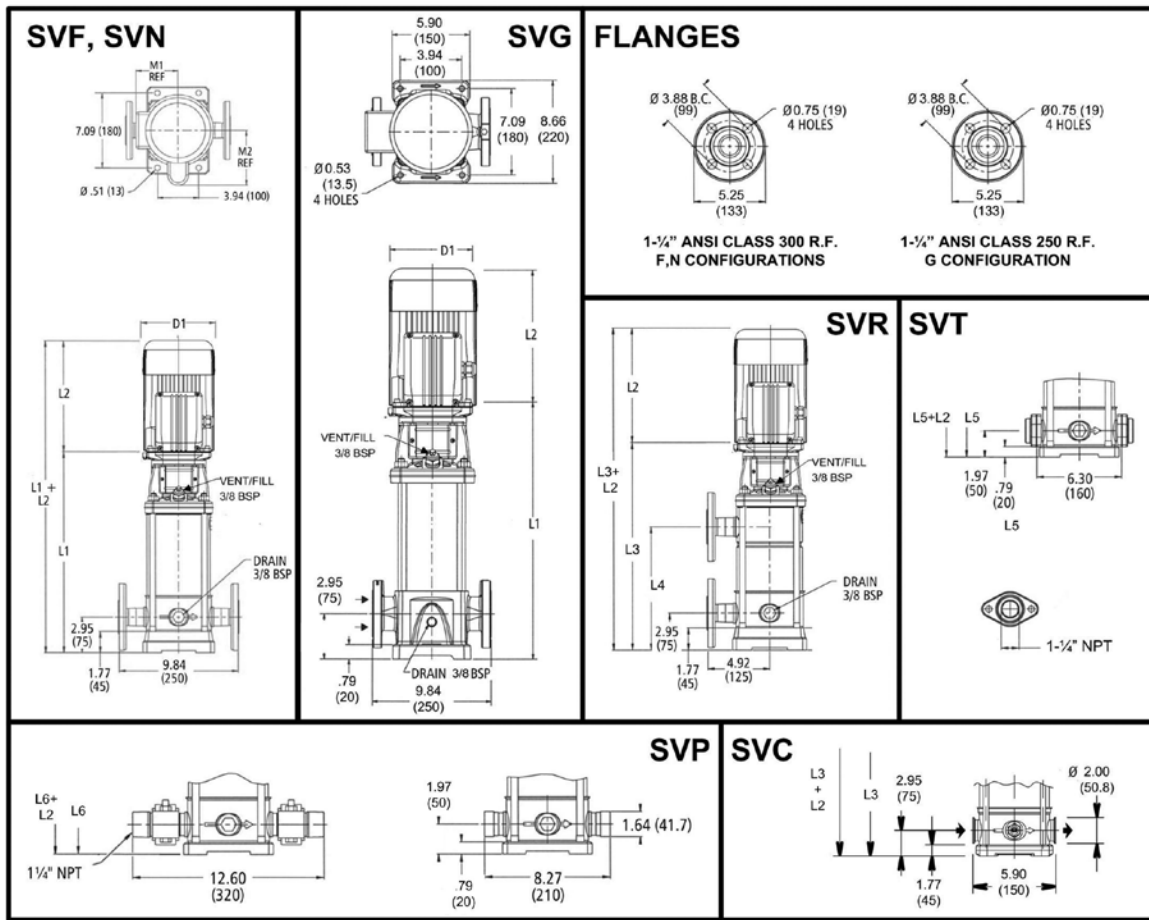

All dimensions are in inches (mm).

3SV SERIES – 60Hz, 1750 RPM ODP/TEFC Enclosures

Pump Type Stages	Motor					Dimensions (in)											Weight (lbs.)												
	HP	NEMA Frame				L2						D1 (max.)					Pump Only	Motor				Pump/Motor							
		ODP 1Ø	TEFC 1Ø	ODP 3Ø	TEFC 3Ø	L1	ODP 1Ø	TEFC 1Ø	ODP 3Ø	TEFC 3Ø	L3	L4	L5	L6	M (Ref.)	ODP 1Ø		TEFC 1Ø	ODP 3Ø	TEFC 3Ø	D2	ODP 1Ø	TEFC 1Ø	ODP 3Ø	TEFC 3Ø	ODP 1Ø	TEFC 1Ø	ODP 3Ø	TEFC 3Ø
3SV-02	0.5	56C				13.27	9.16	9.29	9.16	9.29	-	-	12.29	12.29	5.19	6.19	6.19	6.19	6.19	4.13	24	21	21	19	19	45	45	43	43
3SV-03			13.27	9.16	9.29	9.16	9.29	-	-	12.29	12.29	5.19	6.19	6.19	6.19	6.19	4.13	25	21	21	19	19	46	46	44	44			
3SV-04			14.06	9.16	9.29	9.16	9.29	-	-	13.07	13.07	5.19	6.19	6.19	6.19	6.19	4.13	26	21	21	19	19	47	47	45	45			
3SV-05			14.85	9.16	9.29	9.16	9.29	-	-	13.86	13.86	5.19	6.19	6.19	6.19	6.19	4.13	27	21	21	19	19	48	48	46	46			
3SV-06			15.63	9.16	9.29	9.16	9.29	-	-	14.65	14.65	5.19	6.19	6.19	6.19	6.19	4.13	28	21	21	19	19	49	49	47	47			
3SV-07			16.42	9.16	9.29	9.16	9.29	-	-	15.44	15.44	5.19	6.19	6.19	6.19	6.19	4.13	30	21	21	19	19	51	51	49	49			
3SV-08			17.21	9.16	9.29	9.16	9.29	17.21	8.94	16.22	16.22	5.19	6.19	6.19	6.19	6.19	4.13	31	21	21	19	19	52	52	50	50			
3SV-09			18.00	9.16	9.29	9.16	9.29	18.00	9.72	17.01	17.01	5.19	6.19	6.19	6.19	6.19	4.13	32	21	21	19	19	53	53	51	51			
3SV-10			18.78	9.16	9.29	9.16	9.29	18.78	10.51	17.80	17.80	5.19	6.19	6.19	6.19	6.19	4.13	33	21	21	19	19	54	54	52	52			
3SV-11			19.57	9.16	9.29	9.16	9.29	19.57	11.30	18.59	18.59	5.19	6.19	6.19	6.19	6.19	4.13	34	21	21	19	19	55	55	53	53			
3SV-12			20.36	9.16	9.29	9.16	9.29	20.36	12.09	19.37	19.37	5.19	6.19	6.19	6.19	6.19	4.13	35	21	21	19	19	56	56	54	54			
3SV-13			21.14	9.16	9.29	9.16	9.29	21.14	12.87	20.16	20.16	5.19	6.19	6.19	6.19	6.19	4.13	36	21	21	19	19	57	57	55	55			
3SV-14			21.93	9.16	9.29	9.16	9.29	21.93	13.66	20.95	20.95	5.19	6.19	6.19	6.19	6.19	4.13	37	21	21	19	19	58	58	56	56			
3SV-15			22.72	9.16	9.29	9.16	9.29	22.72	14.45	21.74	21.74	5.19	6.19	6.19	6.19	6.19	4.13	38	21	21	19	19	59	59	57	57			
3SV-16			23.51	9.16	9.29	9.16	9.29	23.51	15.24	22.52	22.52	5.19	6.19	6.19	6.19	6.19	4.13	39	21	21	19	19	60	60	58	58			
3SV-17			24.29	9.16	9.29	9.16	9.29	24.29	16.02	23.31	23.31	5.19	6.19	6.19	6.19	6.19	4.13	40	21	21	19	19	61	61	59	59			
3SV-18			25.08	9.16	9.29	9.16	9.29	25.08	16.81	24.10	24.10	5.19	6.19	6.19	6.19	6.19	4.13	41	21	21	19	19	62	62	60	60			
3SV-19			25.87	9.16	9.29	9.16	9.29	25.87	17.60	24.89	24.89	5.19	6.19	6.19	6.19	6.19	4.13	41	21	21	19	19	62	62	60	60			
3SV-20			26.66	9.16	9.29	9.16	9.29	26.66	18.39	25.67	25.67	5.19	6.19	6.19	6.19	6.19	4.13	42	21	21	19	19	63	63	61	61			
3SV-21			27.44	9.16	9.29	9.16	9.29	27.44	19.17	26.46	26.46	5.19	6.19	6.19	6.19	6.19	4.13	43	21	21	19	19	64	64	62	62			
3SV-22			28.23	9.16	9.29	9.16	9.29	28.23	19.96	27.25	27.25	5.19	6.19	6.19	6.19	6.19	4.13	44	21	21	19	19	65	65	63	63			
3SV-23			29.02	9.16	9.29	9.16	9.29	29.02	20.75	28.03	28.03	5.19	6.19	6.19	6.19	6.19	4.13	45	21	21	19	19	66	66	64	64			
3SV-24			29.81	9.16	9.29	9.16	9.29	29.81	21.54	28.82	28.82	5.19	6.19	6.19	6.19	6.19	4.13	46	21	21	19	19	67	67	65	65			
3SV-25			30.59	9.16	9.29	9.16	9.29	30.59	22.32	29.61	29.61	5.19	6.19	6.19	6.19	6.19	4.13	47	21	21	19	19	68	68	66	66			
3SV-26			0.75	56C				31.38	10.79	9.91	9.16	9.29	31.38	23.11	30.40	30.40	5.19	6.19	6.19	6.19	6.19	4.13	48	27	29	21	21	75	77
3SV-27	31.77	10.79			9.91	9.16	9.29	31.77	23.90	30.79	30.79	5.19	6.19	6.19	6.19	6.19	4.13	50	27	29	21	21	77	79	71	71			
3SV-28	32.56	10.79			9.91	9.16	9.29	32.56	24.68	31.58	31.58	5.19	6.19	6.19	6.19	6.19	4.13	51	27	29	21	21	78	80	72	72			
3SV-29	33.74	10.79			9.91	9.16	9.29	33.74	25.47	32.76	32.76	5.19	6.19	6.19	6.19	6.19	4.13	52	27	29	21	21	79	81	73	73			
3SV-30	34.53	10.79			9.91	9.16	9.29	34.53	26.26	33.55	33.55	5.19	6.19	6.19	6.19	6.19	4.13	53	27	29	21	21	80	82	74	74			

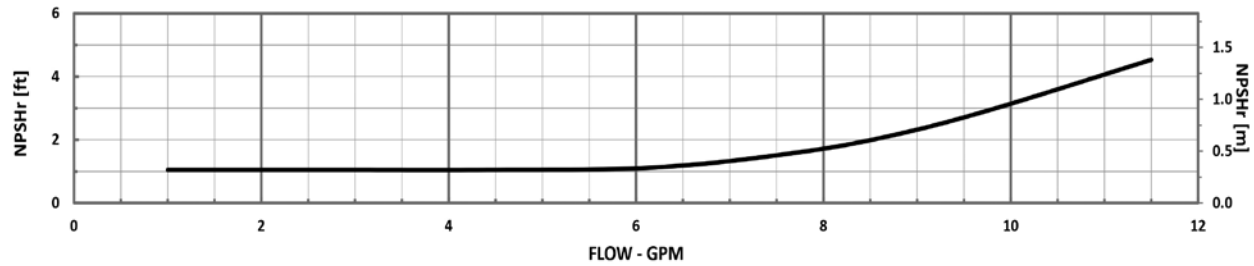
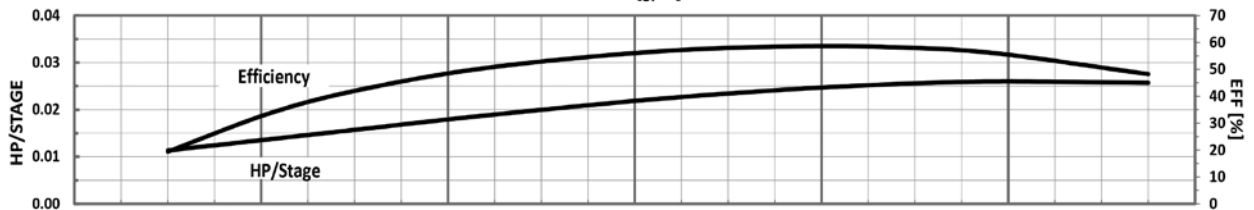
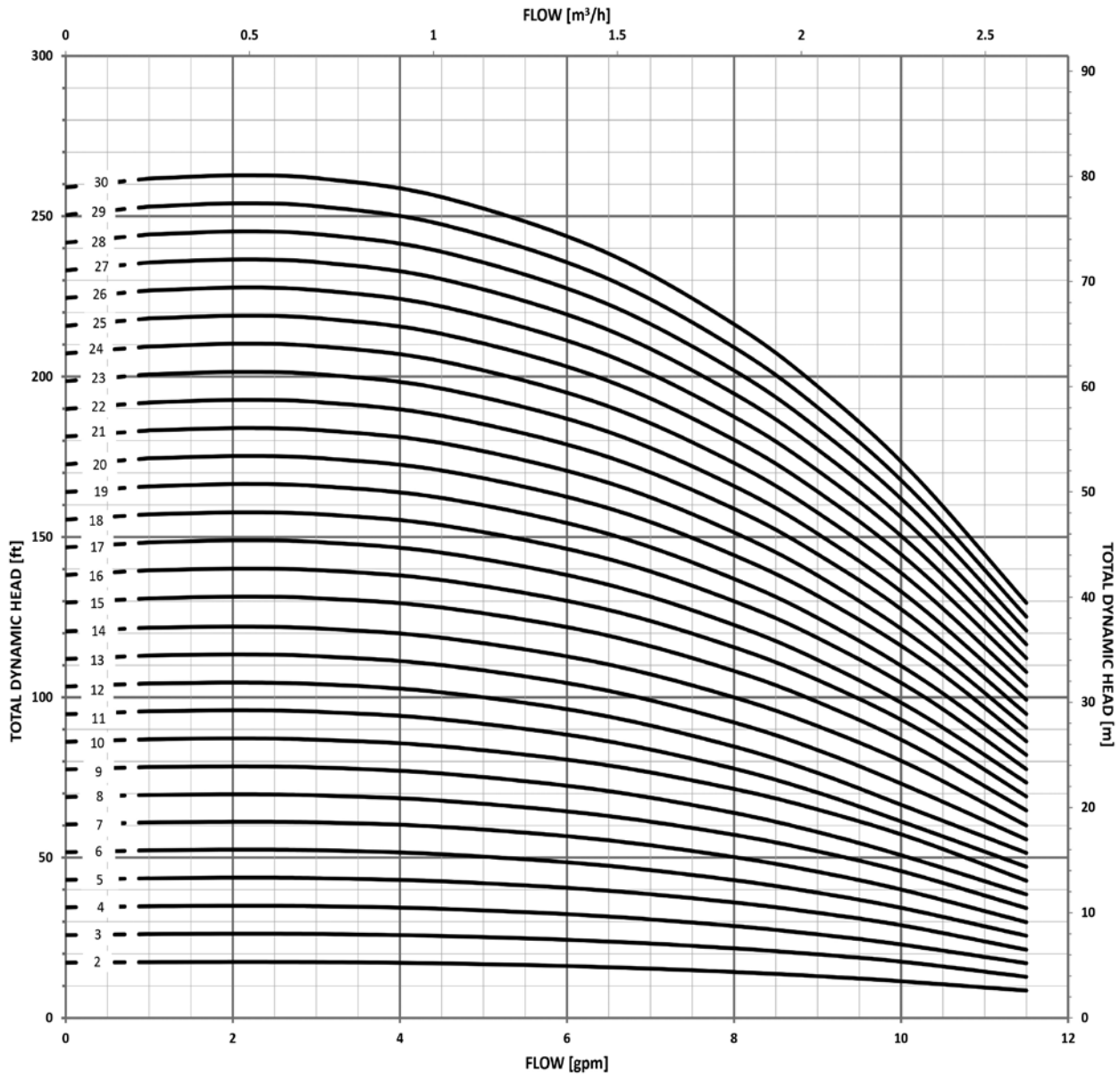

MINIMUM FLOW RATE: 1 GPM [.24 m³/hr]

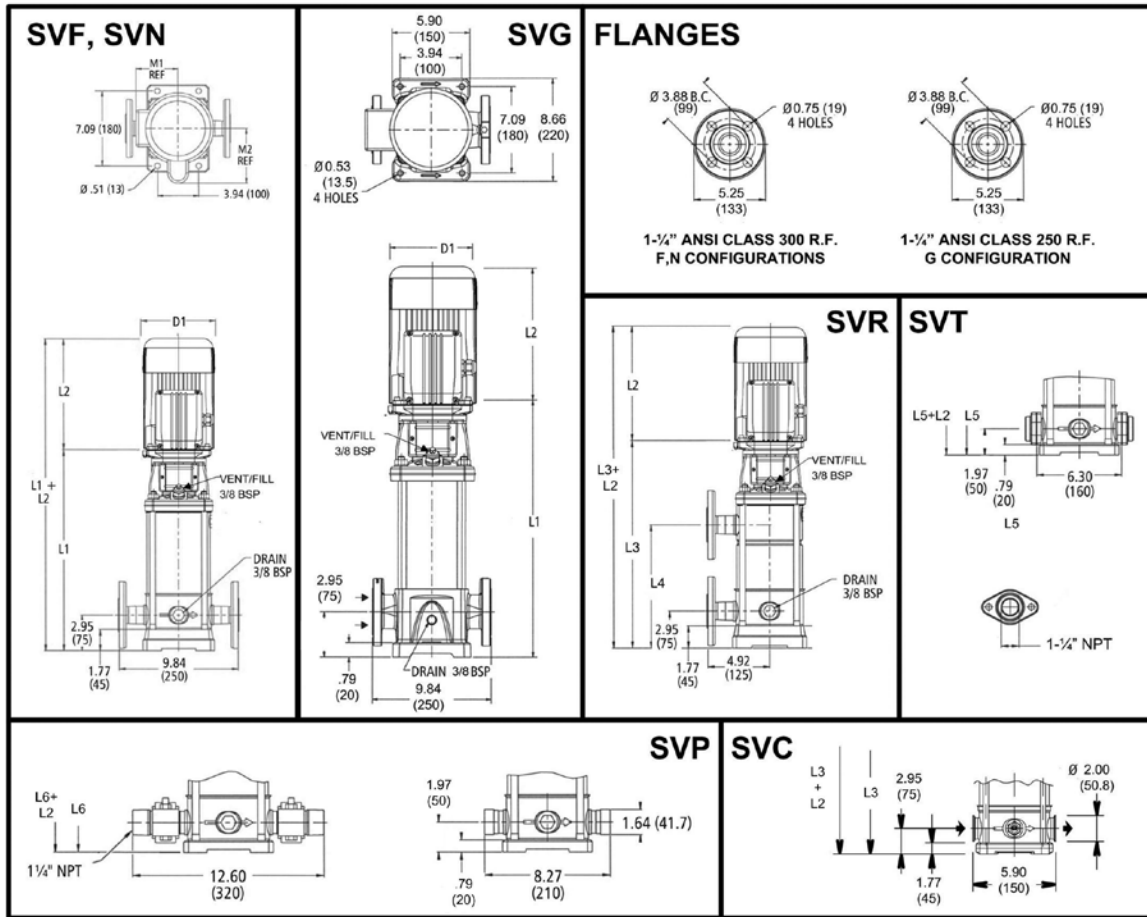

5SV SERIES – 60Hz, 1750 RPM ODP/TEFC Enclosures

Pump Type Stages	Motor					Dimensions (in)											Weight (lbs.)													
	HP	NEMA Frame				L1	L2					L3	L4	L5	L6	M (Ref.)	D1 (max.)				D2	Pump Only	Motor				Pump/Motor			
		ODP 1Ø	TEFC 1Ø	ODP 3Ø	TEFC 3Ø		ODP 1Ø	TEFC 1Ø	ODP 3Ø	TEFC 3Ø	ODP 1Ø						TEFC 1Ø	ODP 3Ø	TEFC 3Ø	ODP 1Ø			TEFC 1Ø	ODP 3Ø	TEFC 3Ø	ODP 1Ø	TEFC 1Ø	ODP 3Ø	TEFC 3Ø	
5SV-02	0.5	56C				13.86	9.16	9.29	9.16	9.29	-	-	12.88	12.88	5.19	6.19	6.19	6.19	6.19	4.13	25	21	19	19	46	46	44	44		
5SV-03						13.86	9.16	9.29	9.16	9.29	-	-	12.88	12.88	5.19	6.19	6.19	6.19	6.19	4.13	26	21	21	19	19	47	47	45	45	
5SV-04						14.85	9.16	9.29	9.16	9.29	-	-	13.86	13.86	5.19	6.19	6.19	6.19	6.19	4.13	28	21	21	19	19	49	49	47	47	
5SV-05						15.83	9.16	9.29	9.16	9.29	-	-	14.85	14.85	5.19	6.19	6.19	6.19	6.19	4.13	29	21	21	19	19	50	50	48	48	
5SV-06						16.81	9.16	9.29	9.16	9.29	-	-	15.83	15.83	5.19	6.19	6.19	6.19	6.19	4.13	30	21	21	19	19	51	51	49	49	
5SV-07						17.80	9.16	9.29	9.16	9.29	17.80	9.53	16.81	16.81	5.19	6.19	6.19	6.19	6.19	4.13	31	21	21	19	19	52	52	50	50	
5SV-08						18.78	9.16	9.29	9.16	9.29	18.78	10.51	17.80	17.80	5.19	6.19	6.19	6.19	6.19	4.13	33	21	21	19	19	54	54	52	52	
5SV-09						19.77	9.16	9.29	9.16	9.29	19.77	11.50	18.78	18.78	5.19	6.19	6.19	6.19	6.19	4.13	33	21	21	19	19	54	54	52	52	
5SV-10						20.75	9.16	9.29	9.16	9.29	20.75	12.48	19.77	19.77	5.19	6.19	6.19	6.19	6.19	4.13	34	21	21	19	19	55	55	53	53	
5SV-11						21.74	9.16	9.29	9.16	9.29	21.74	13.46	20.75	20.75	5.19	6.19	6.19	6.19	6.19	4.13	35	21	21	19	19	56	56	54	54	
5SV-12						22.72	9.16	9.29	9.16	9.29	22.72	14.45	21.74	21.74	5.19	6.19	6.19	6.19	6.19	4.13	36	21	21	19	19	57	57	55	55	
5SV-13						23.70	9.16	9.29	9.16	9.29	23.70	15.43	22.72	22.72	5.19	6.19	6.19	6.19	6.19	4.13	38	21	21	19	19	59	59	57	57	
5SV-14						24.69	9.16	9.29	9.16	9.29	24.69	16.42	23.70	23.70	5.19	6.19	6.19	6.19	6.19	4.13	38	21	21	19	19	59	59	57	57	
5SV-15						25.67	9.16	9.29	9.16	9.29	25.67	17.40	24.69	24.69	5.19	6.19	6.19	6.19	6.19	4.13	39	21	21	19	19	60	60	58	58	
5SV-16						26.66	9.16	9.29	9.16	9.29	26.66	18.39	25.67	25.67	5.19	6.19	6.19	6.19	6.19	4.13	41	21	21	19	19	62	62	60	60	
5SV-17						27.84	10.79	9.91	9.16	9.29	27.84	19.37	26.85	26.85	5.19	6.19	6.19	6.19	6.19	4.13	43	27	29	21	21	70	72	64	64	
5SV-18						28.63	10.79	9.91	9.16	9.29	28.63	20.35	27.64	27.64	5.19	6.19	6.19	6.19	6.19	4.13	44	27	29	21	21	71	73	65	65	
5SV-19						29.81	10.79	9.91	9.16	9.29	29.81	21.34	28.82	28.82	5.19	6.19	6.19	6.19	6.19	4.13	45	27	29	21	21	72	74	66	66	
5SV-20	0.75			30.99	10.79	9.91	9.16	9.29	30.99	22.32	30.00	30.00	5.19	6.19	6.19	6.19	6.19	4.13	46	27	29	21	21	73	75	67	67			
5SV-21				31.58	10.79	9.91	9.16	9.29	31.58	23.31	30.59	30.59	5.19	6.19	6.19	6.19	6.19	4.13	47	27	29	21	21	74	76	68	68			
5SV-22				32.64	10.79	9.91	9.16	9.29	32.64	24.29	31.66	31.66	5.19	6.19	6.19	6.19	6.19	4.13	48	27	29	21	21	75	77	69	69			
5SV-23				33.55	10.79	9.91	9.16	9.29	33.55	25.28	32.56	32.56	5.19	6.19	6.19	6.19	6.19	4.13	49	27	29	21	21	76	78	70	70			
5SV-24				34.61	10.79	9.91	9.16	9.29	34.61	26.26	33.63	33.63	5.19	6.19	6.19	6.19	6.19	4.13	51	27	29	21	21	78	80	72	72			
5SV-25				35.51	10.66	11.19	9.16	9.29	35.51	27.24	34.53	34.53	5.74	6.19	7.19	6.19	6.19	4.13	51	32	40	23	23	83	91	74	74			
5SV-26	1			36.58	10.66	11.19	9.16	9.29	36.58	28.23	35.59	35.59	5.74	6.19	7.19	6.19	6.19	4.13	52	32	40	23	23	84	92	75	75			
5SV-27				37.56	10.66	11.19	9.16	9.29	37.56	29.21	36.58	36.58	5.74	6.19	7.19	6.19	6.19	4.13	53	32	40	23	23	85	93	76	76			

Performance Curve

5SV 1750 RPM

60 Hz

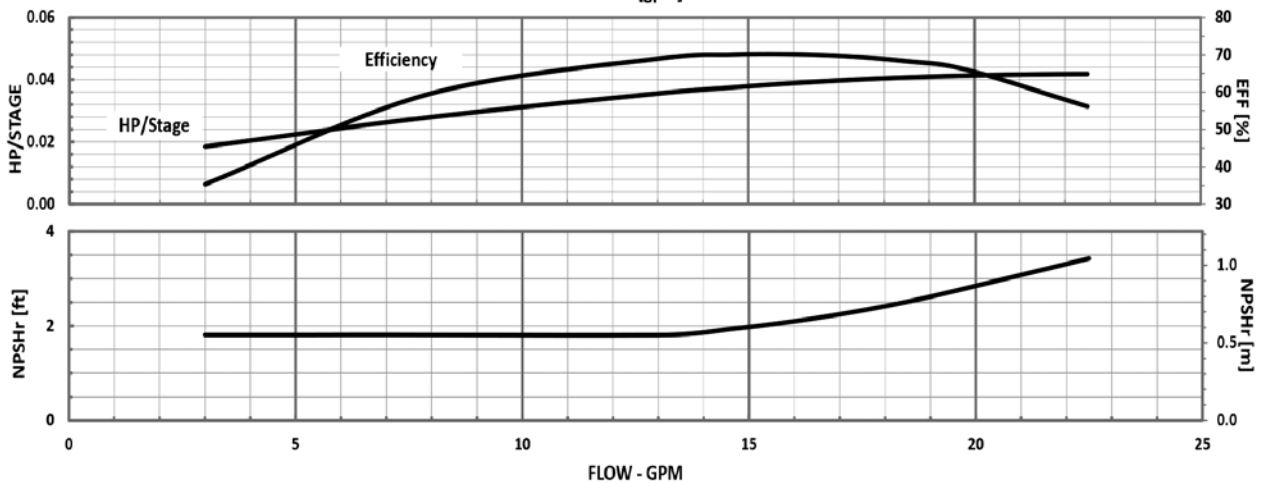
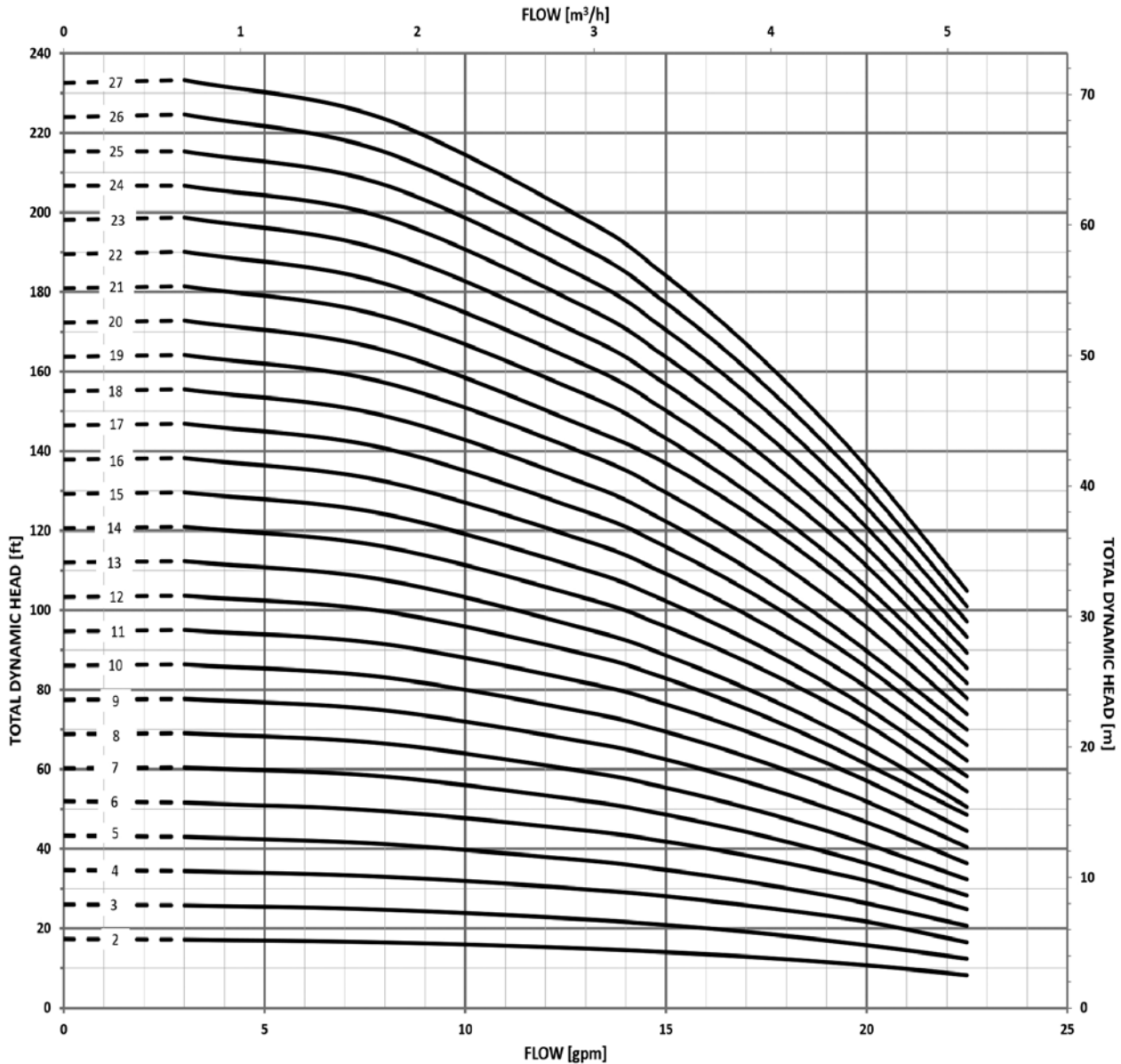

MINIMUM FLOW RATE: 3 GPM [$.7 m^3/hr$]

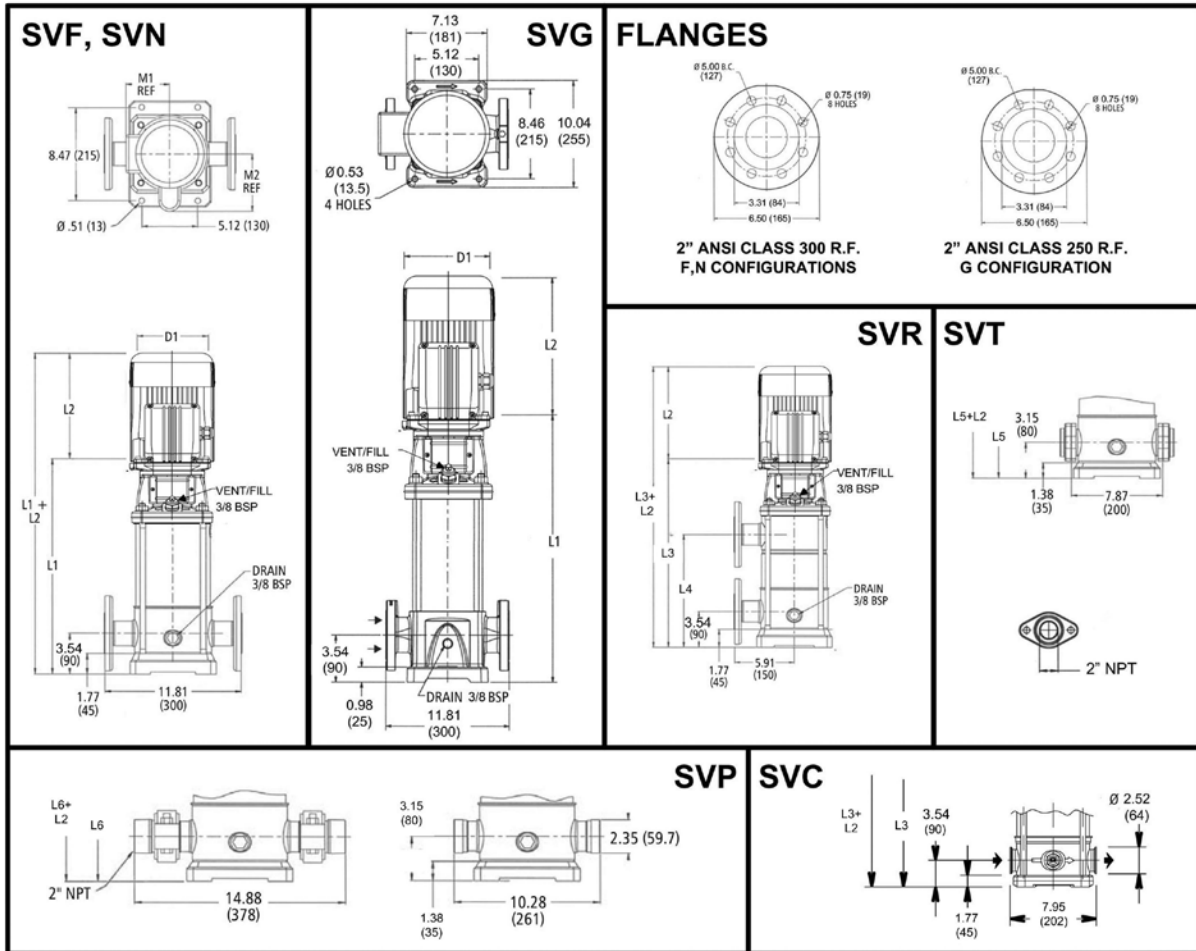

All dimensions are in inches (mm).

10SV SERIES – 60Hz, 1750 RPM ODP/TEFC Enclosures

Pump Type Stages	Motor				Dimensions (in)													Weight (lbs.)										
	HP	NEMA Frame			L2								D1 (max.)					Pump Only	Motor				Pump/Motor					
		ODP 1Ø	TEFC 1Ø	ODP 3Ø	TEFC 3Ø	L1	ODP 1Ø	TEFC 1Ø	ODP 3Ø	TEFC 3Ø	L3	L4	L5	L6	M (Ref.)	ODP 1Ø	TEFC 1Ø		ODP 3Ø	TEFC 3Ø	D2	ODP 1Ø	TEFC 1Ø	ODP 3Ø	TEFC 3Ø	ODP 1Ø	TEFC 1Ø	ODP 3Ø
10SV01	56C				16.56	9.16	9.29	9.16	9.29	-	-	16.17	16.17	5.19	6.2	6.19	6.19	6.19	4.13	36	21	21	19	19	57	57	55	55
10SV02					16.56	9.16	9.29	9.16	9.29	-	-	16.17	16.17	5.19	6.2	6.19	6.19	6.19	4.13	38	21	21	19	19	59	59	57	57
10SV03					17.82	9.16	9.29	9.16	9.29	-	-	17.43	17.43	5.19	6.2	6.19	6.19	6.19	4.13	40	21	21	19	19	61	61	59	59
10SV04					19.08	9.16	9.29	9.16	9.29	-	-	18.69	18.69	5.19	6.2	6.19	6.19	6.19	4.13	43	21	21	19	19	64	64	62	62
10SV05					20.34	9.16	9.29	9.16	9.29	20.34	10.20	19.95	19.95	5.19	6.2	6.19	6.19	6.19	4.13	45	21	21	19	19	66	66	64	64
10SV06					21.60	10.79	9.91	9.16	9.29	21.60	11.46	21.21	21.21	5.19	6.19	6.19	6.19	6.19	4.13	47	27	29	21	21	74	76	68	68
10SV07					22.86	10.79	9.91	9.16	9.29	22.86	12.72	22.47	22.47	5.19	6.19	6.19	6.19	6.19	4.13	49	27	29	21	21	76	78	70	70
10SV08					24.12	10.79	9.91	9.16	9.29	24.12	13.98	23.72	23.72	5.19	6.19	6.19	6.19	6.19	4.13	51	27	29	21	21	78	80	72	72
10SV09					25.38	10.66	11.19	9.16	9.29	25.38	15.24	24.98	24.98	5.74	6.2	7.19	6.19	6.19	4.13	53	32	40	23	23	85	93	76	76
10SV10					26.64	10.66	11.19	9.16	9.29	26.64	16.50	26.24	26.24	5.74	6.2	7.19	6.19	6.19	4.13	56	32	40	23	23	88	96	79	79
10SV11					27.90	10.67	11.19	10.66	9.91	27.90	17.76	27.50	27.50	5.74	6.2	7.19	6.19	6.19	4.72	58	32	40	30	28	90	98	88	86
10SV12					28.37	10.67	11.19	10.66	9.91	28.37	19.02	27.98	27.98	5.74	6.2	7.19	6.19	6.19	4.72	60	32	40	30	28	92	100	90	88
10SV13					30.44	10.67	11.19	10.66	9.91	30.44	20.28	30.04	30.04	5.74	6.2	7.19	6.19	6.19	4.72	65	32	40	30	28	97	105	95	93
10SV14					31.78	10.67	11.19	10.66	9.91	31.78	21.54	31.38	31.38	5.74	6.2	7.19	6.19	6.19	4.72	67	32	40	30	28	99	107	97	95
10SV15					32.96	11.18	12.06	11.16	10.79	32.96	22.80	32.56	32.56	5.74	7.19	7.19	6.19	6.19	4.72	69	43	51	32	33	112	120	101	102
10SV16					34.22	11.18	12.06	11.16	10.79	34.22	24.06	33.82	33.82	5.74	7.19	7.19	6.19	6.19	4.72	71	43	51	32	33	114	122	103	104
10SV17					35.48	11.18	12.06	11.16	10.79	35.48	25.31	35.08	35.08	5.74	7.19	7.19	6.19	6.19	4.72	73	43	51	32	33	116	124	105	106
10SV18					36.74	11.18	12.06	11.16	10.79	36.74	26.57	36.34	36.34	5.74	7.19	7.19	6.19	6.19	4.72	75	43	51	32	33	118	126	107	108
10SV19					38.08	11.18	12.06	11.16	10.79	38.08	27.83	37.68	37.68	5.74	7.19	7.19	6.19	6.19	4.72	77	43	51	32	33	120	128	109	110
10SV20					39.26	11.57	13.44	11.18	11.16	39.26	29.09	38.86	38.86	5.75	6.5	7.19	7.16	7.19	5.51	79	49	64	41	44	128	143	120	123

Performance Curve

10SV 1750 RPM

60 Hz

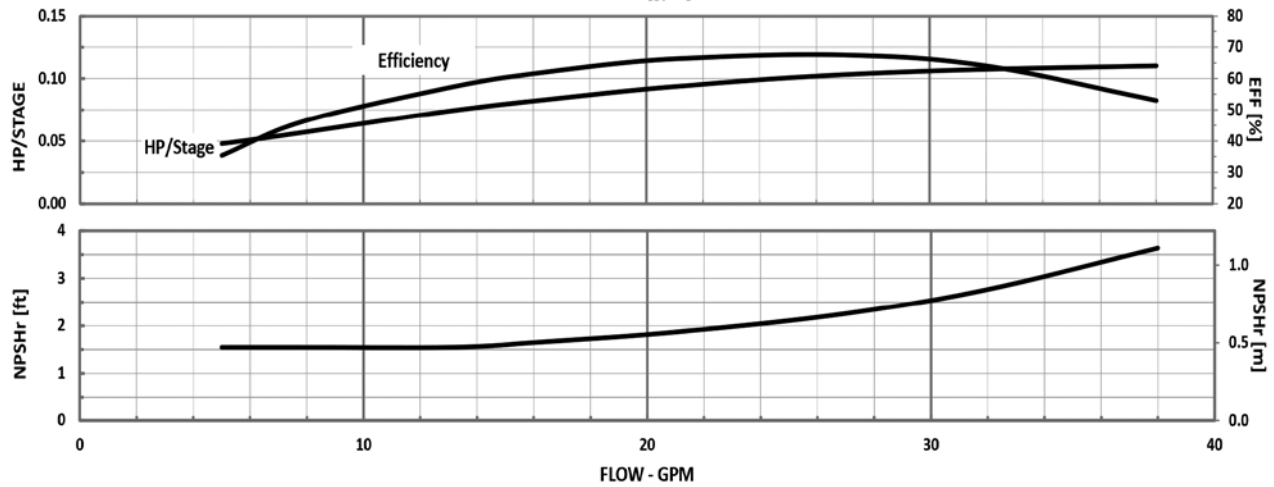
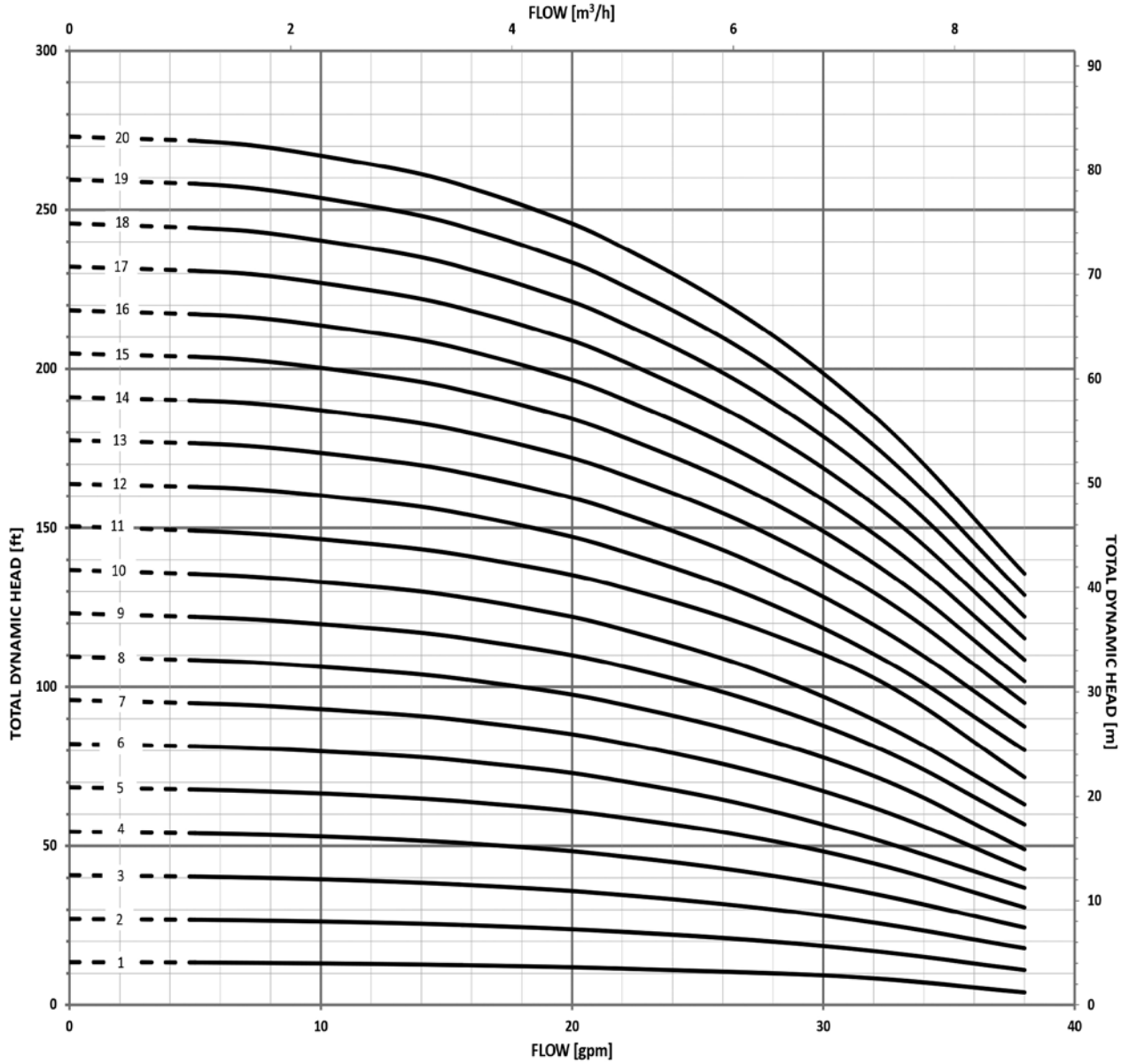

MINIMUM FLOW RATE: 5 GPM [1.4 m³/hr]

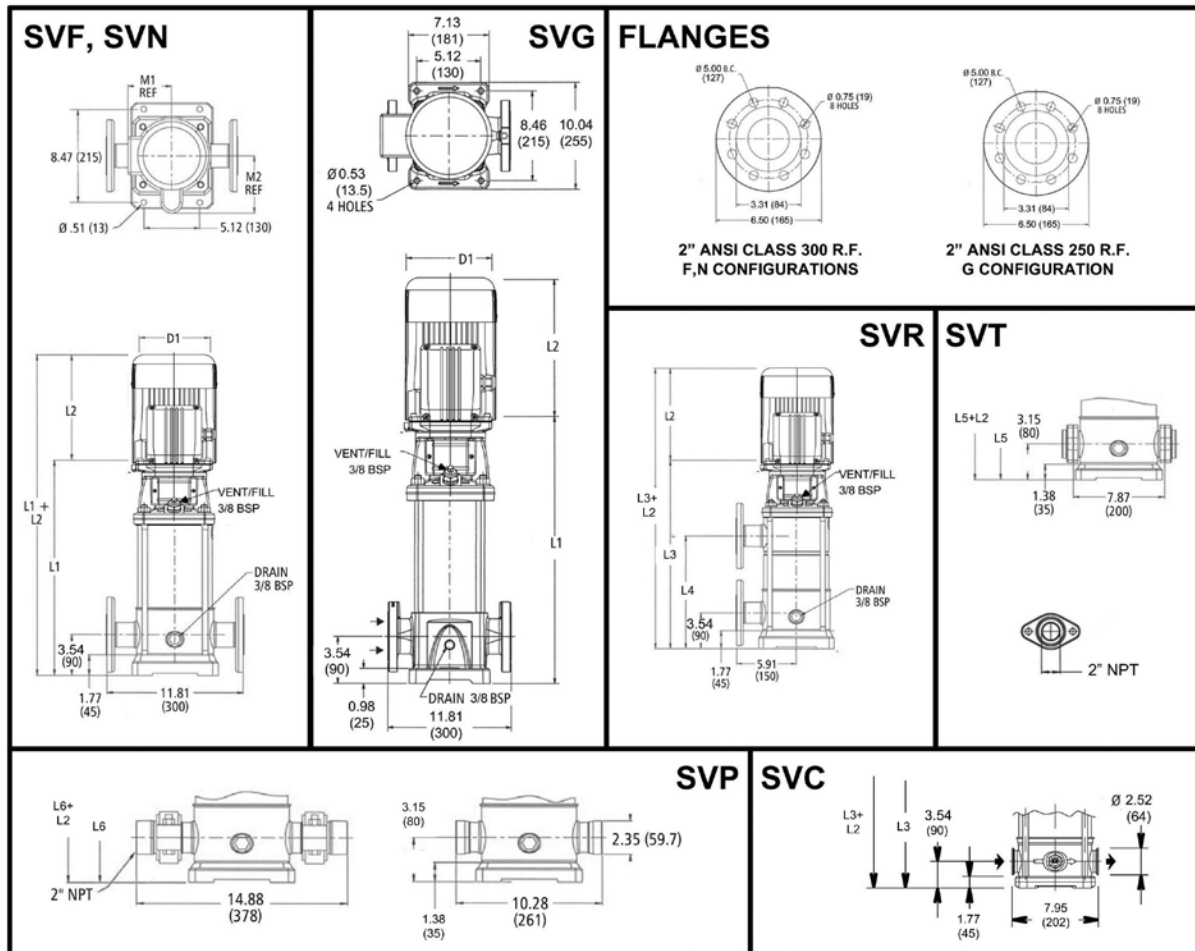

All dimensions are in inches (mm).

15SV SERIES – 60Hz, 1750 RPM ODP/TEFC Enclosures

Pump Type Stages	HP	Motor				Dimensions (in)													Weight (lbs.)										
		NEMA Frame				L1	L2				L3	L4	L5	L6	M (Ref.)	D1 (max.)				D2	Pump Only	Motor				Pump/Motor			
		ODP 1Ø	TEFC 1Ø	ODP 3Ø	TEFC 3Ø		ODP 1Ø	TEFC 1Ø	ODP 3Ø	TEFC 3Ø						ODP 1Ø	TEFC 1Ø	ODP 3Ø	TEFC 3Ø			ODP 1Ø	TEFC 1Ø	ODP 3Ø	TEFC 3Ø	ODP 1Ø	TEFC 1Ø	ODP 3Ø	TEFC 3Ø
15SV-01	0.5	56C				18.61	9.16	9.29	9.16	9.29	-	-	18.21	18.21	5.19	6.19	6.19	6.19	6.19	4.13	38	21	21	19	19	59	59	57	57
15SV-02						18.21	9.16	9.29	9.16	9.29	-	-	17.82	17.82	5.19	6.19	6.19	6.19	6.19	4.13	41	21	21	19	19	62	62	60	60
15SV-03	0.75		20.10	10.79	9.91	9.16	9.29	-	-	19.71	19.71	5.19	6.19	6.19	6.19	6.19	4.13	44	27	29	21	21	71	73	65	65			
15SV-04			21.99	10.66	11.19	9.16	9.29	21.99	11.85	21.60	21.60	5.74	6.19	7.19	6.19	6.19	4.13	47	32	40	23	23	79	87	70	70			
15SV-05	1		23.88	10.66	11.19	9.16	9.29	23.88	13.74	23.49	23.49	5.74	6.19	7.19	6.19	6.19	4.13	49	32	40	23	23	81	89	72	72			
15SV-06			25.79	10.67	11.19	10.66	9.91	25.79	15.63	25.40	25.40	5.74	6.19	7.19	6.19	6.19	4.72	56	32	40	30	28	88	96	86	84			
15SV-07	1.5		27.68	10.67	11.19	10.66	9.91	27.68	17.52	27.29	27.29	5.74	6.19	7.19	6.19	6.19	4.72	59	32	40	30	28	91	99	89	87			
15SV-08			29.57	11.18	12.06	11.16	10.79	29.57	19.41	29.18	29.18	5.74	7.19	7.19	6.19	6.19	4.72	61	43	51	32	33	104	112	93	94			
15SV-09	2		31.46	11.18	12.06	11.16	10.79	31.46	21.30	31.07	31.07	5.74	7.19	7.19	6.19	6.19	4.72	64	43	51	32	33	107	115	96	97			
15SV-10			33.35	11.57	13.44	11.18	11.16	33.35	23.19	32.96	32.96	5.75	6.50	7.19	7.16	7.19	5.51	68	49	64	41	44	117	132	109	112			
15SV-11	3		35.24	11.57	13.44	11.18	11.16	35.24	25.08	34.85	34.85	5.75	6.50	7.19	7.16	7.19	5.51	71	49	64	41	44	120	135	112	115			
15SV-12			37.13	11.57	13.44	11.18	11.16	37.13	26.97	36.74	36.74	5.75	6.50	7.19	7.16	7.19	5.51	74	49	64	41	44	123	138	115	118			
15SV-13			39.02	11.57	13.44	11.18	11.16	39.02	28.86	38.63	38.63	5.75	6.50	7.19	7.16	7.19	5.51	77	49	64	41	44	126	141	118	121			
15SV-14			40.91	11.57	13.44	11.18	11.16	40.91	30.75	40.52	40.52	5.75	6.50	7.19	7.16	7.19	5.51	80	49	64	41	44	129	144	121	124			
15SV-15	5	184TC	182TC	184TC	43.30	13.93	15.43	12.55	13.93	43.30	32.64	42.91	42.91	6.87	8.88	8.86	9.02	8.86	5.51	86	81	92	62	69	167	178	148	155	

Performance Curve

15SV 1750 RPM

60 Hz

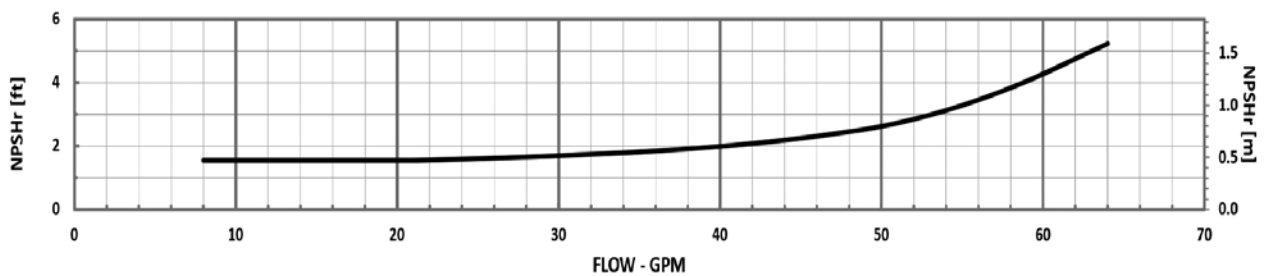
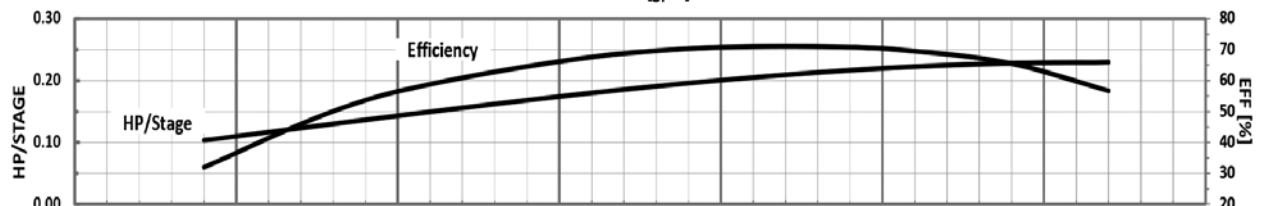
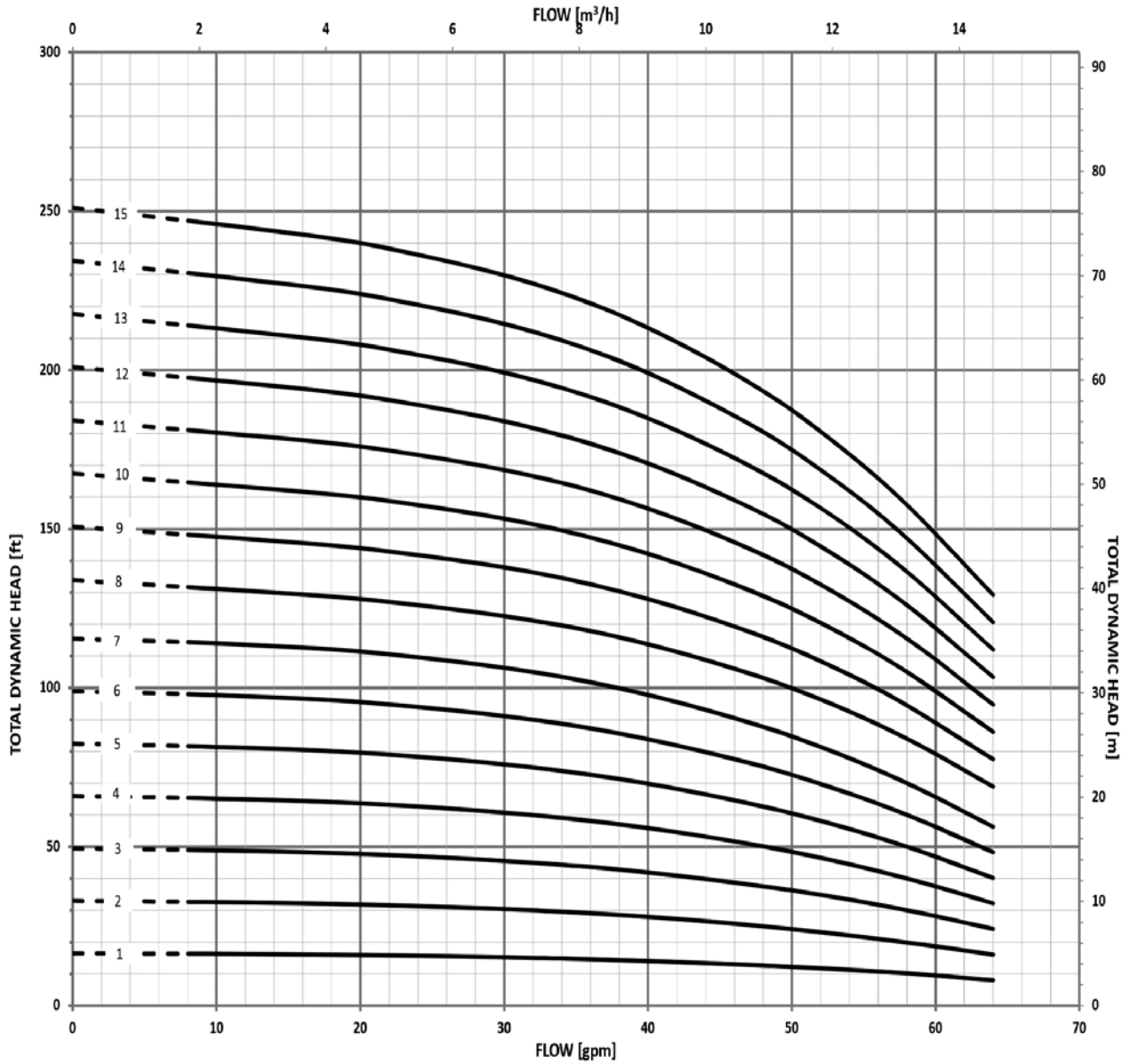

MINIMUM FLOW RATE: 8 GPM [2 m³/hr]

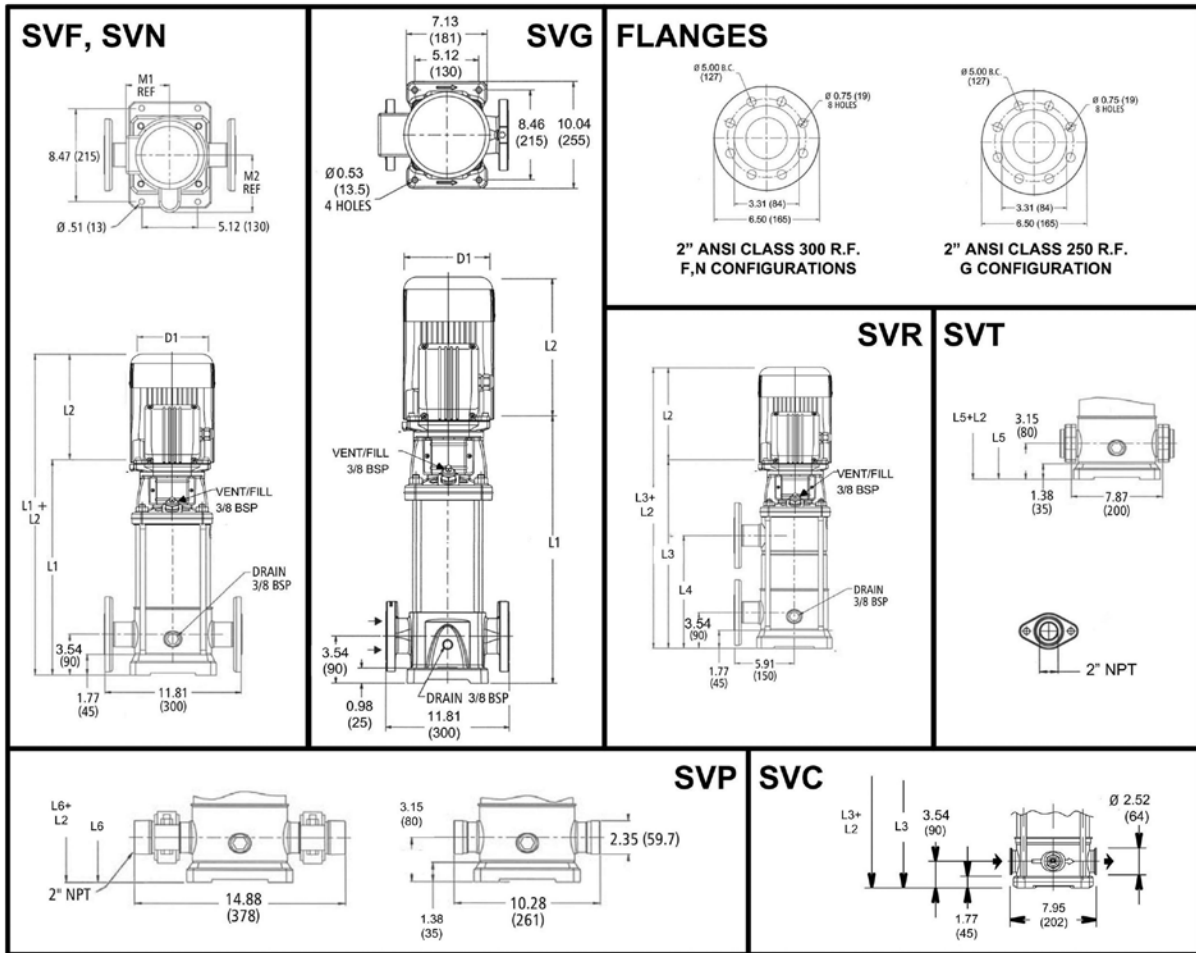

22SV SERIES – 60Hz, 1750 RPM ODP/TEFC Enclosures

Pump Type Stages	HP	Motor				Dimensions (in)															Weight (lbs.)									
		NEMA Frame				L2					D1 (max.)					Pump Only	Motor				Pump/Motor									
		ODP 1Ø	TEFC 1Ø	ODP 3Ø	TEFC 3Ø	L1	ODP 1Ø	TEFC 1Ø	ODP 3Ø	TEFC 3Ø	L3	L4	L5	L6	M (Ref.)		ODP 1Ø	TEFC 1Ø	ODP 3Ø	TEFC 3Ø	D2	ODP 1Ø	TEFC 1Ø	ODP 3Ø	TEFC 3Ø	ODP 1Ø	TEFC 1Ø	ODP 3Ø	TEFC 3Ø	
22SV01	0.5	56C	184TC	182TC	184TC	18.61	9.16	9.29	9.16	9.29	-	-	18.21	18.21	5.19	6.19	6.19	6.19	6.19	4.13	39	21	21	19	19	60	60	58	58	
22SV02						18.21	9.16	9.29	9.16	9.29	-	-	17.82	17.82	5.19	6.19	6.19	6.19	6.19	6.19	6.19	4.13	42	21	21	19	19	63	63	61
22SV03	0.75					20.10	10.79	9.91	9.16	9.29	-	-	19.71	19.71	5.19	6.19	6.19	6.19	6.19	6.19	4.13	45	27	29	21	21	72	74	66	66
22SV04						21.99	10.67	11.19	10.66	9.91	21.99	11.85	21.60	21.60	5.74	6.19	7.19	6.19	6.19	6.19	4.72	48	32	40	30	28	80	88	78	76
22SV05	1.5					23.90	10.67	11.19	10.66	9.91	23.90	13.74	23.51	23.51	5.74	6.19	7.19	6.19	6.19	6.19	4.72	51	32	40	30	28	83	91	81	79
22SV06						25.79	11.18	12.06	11.16	10.79	25.79	15.63	25.40	25.40	5.74	7.19	7.19	6.19	6.19	6.19	4.72	54	43	51	32	33	97	105	86	87
22SV07	2					27.68	11.18	12.06	11.16	10.79	27.68	17.52	27.29	27.29	5.74	7.19	7.19	6.19	6.19	6.19	4.72	57	43	51	32	33	100	108	89	90
22SV08						29.57	11.57	13.44	11.18	11.16	29.57	19.41	29.18	29.18	5.75	6.50	7.19	7.19	6.19	6.19	5.51	60	49	64	41	44	109	124	101	104
22SV09	3					31.46	11.57	13.44	11.18	11.16	31.46	21.30	31.07	31.07	5.75	6.50	7.19	7.16	7.19	5.51	62	49	64	41	44	111	126	103	106	
22SV10						33.35	11.57	13.44	11.18	11.16	33.35	23.19	32.96	32.96	5.75	6.50	7.19	7.16	7.19	5.51	66	49	64	41	44	115	130	107	110	
22SV11						35.24	11.57	13.44	11.18	11.16	35.24	25.08	34.85	34.85	5.75	6.50	7.19	7.16	7.19	5.51	69	49	64	41	44	118	133	110	113	
22SV12	5	184TC	182TC	184TC	37.63	13.93	15.43	12.55	13.93	37.63	26.97	37.24	37.24	6.87	8.88	8.86	9.02	8.86	5.51	75	81	92	62	69	156	167	137	144		

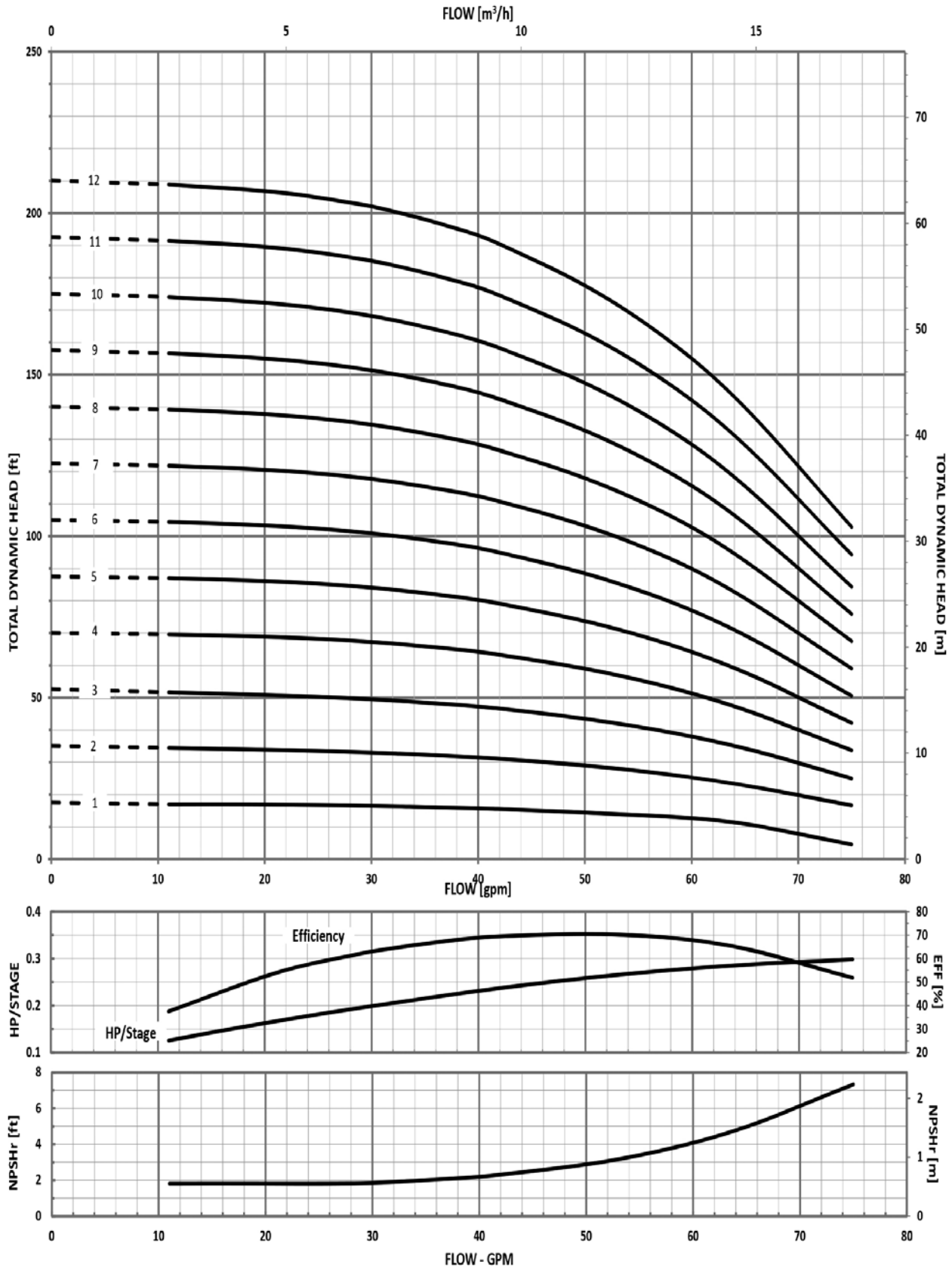

MINIMUM FLOW RATE: 11 GPM [2.5 m³/hr]

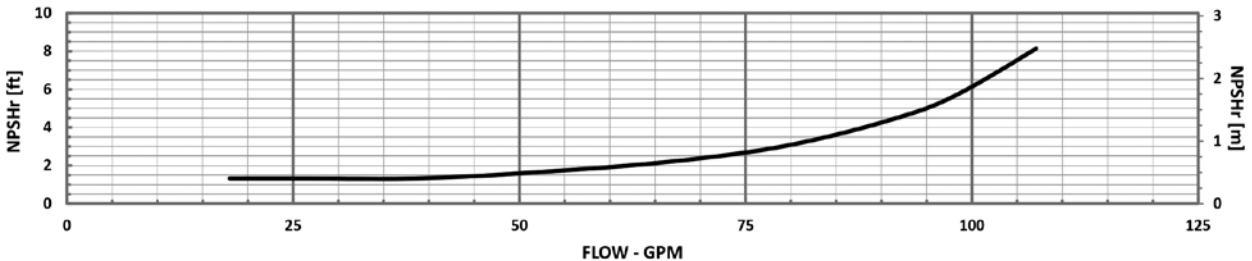
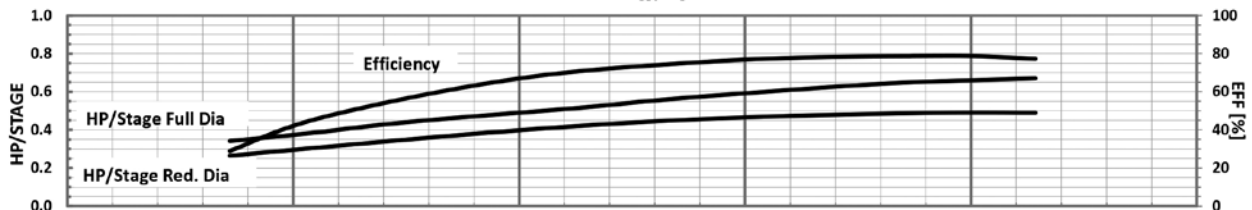
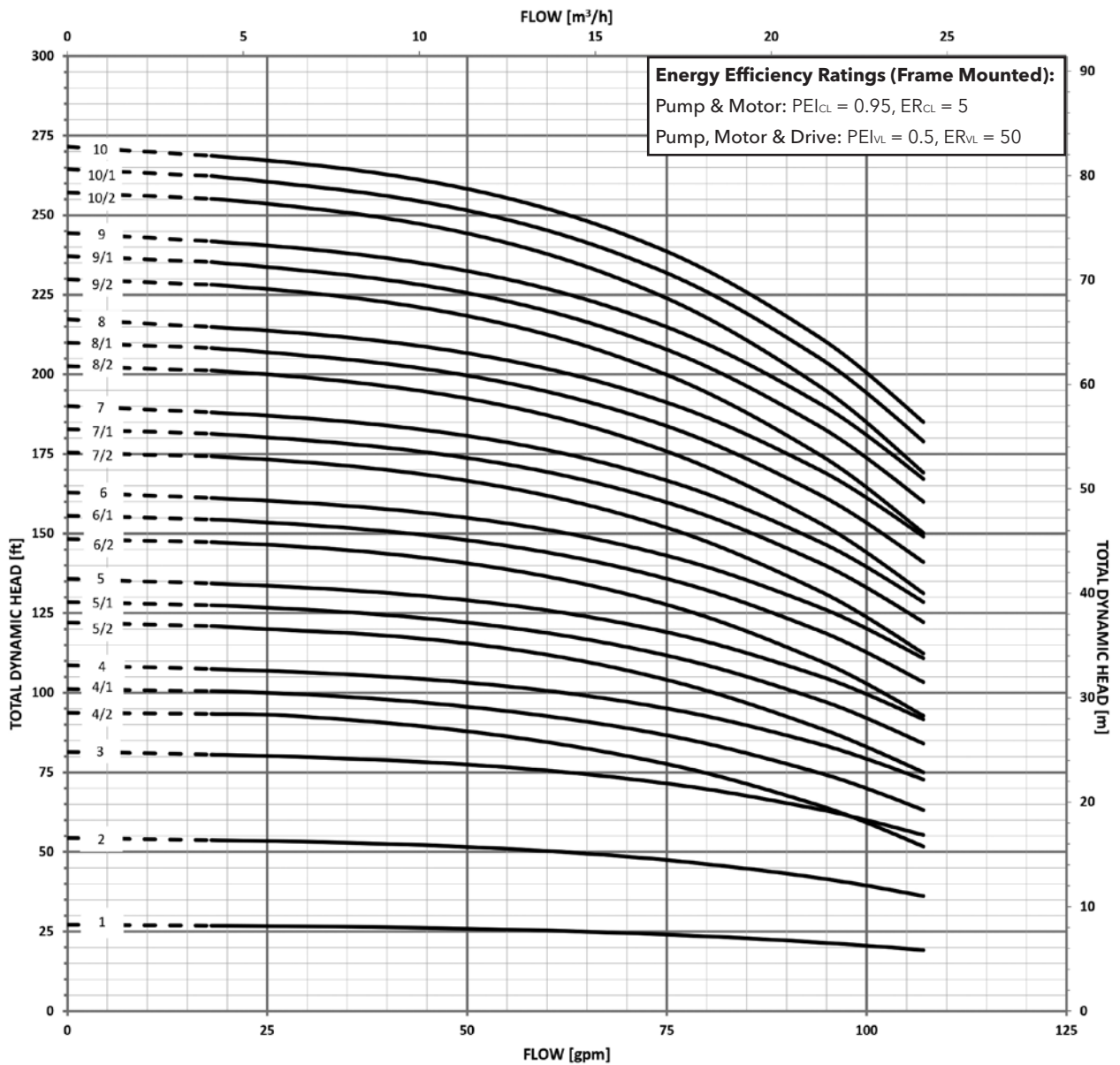

MINIMUM FLOW RATE: 18 GPM [4 m³/hr]

Commercial Water

Dimensions and Weights

46SV Series 1750 RPM

60 Hz

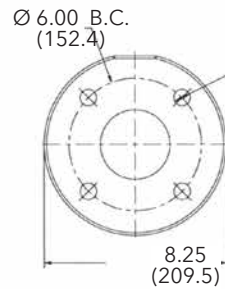
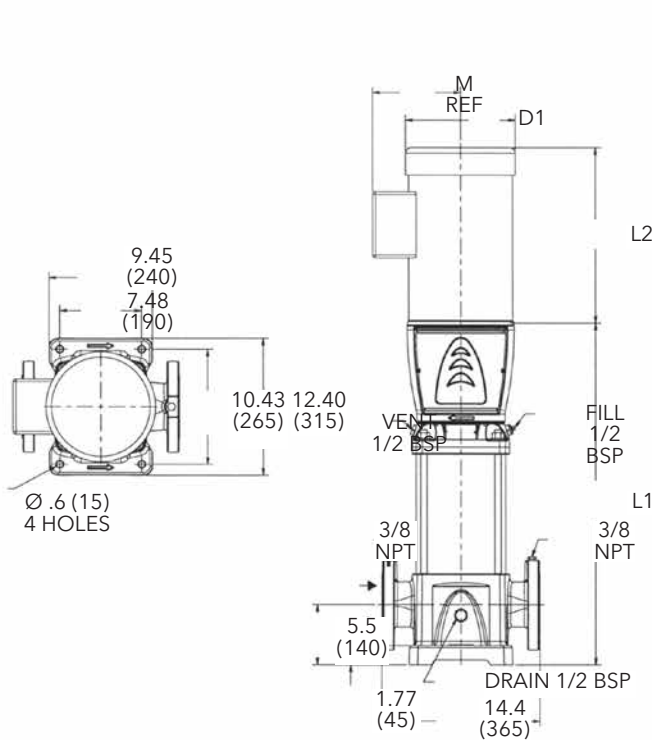

Cast Iron
3" Class 125 F.F.

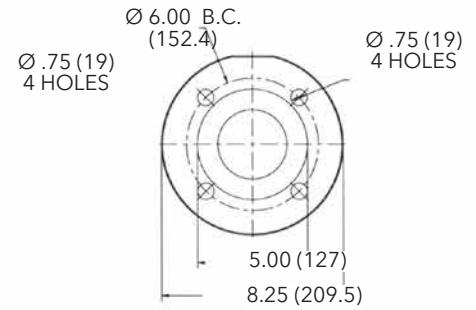

316SS
3" Class 150 R.F.

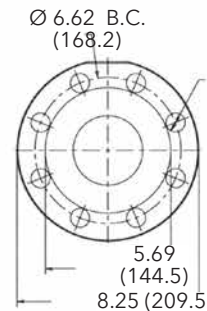

Cast Iron
3" Class 250 R.F.

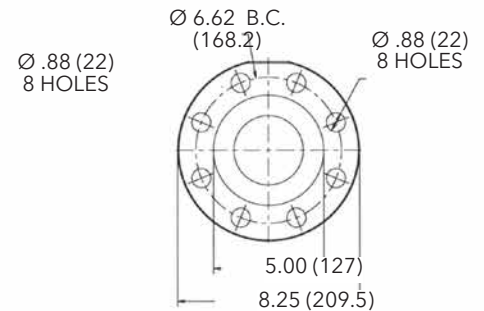

316SS
3" Class 300 R.F.

All dimensions are in inches (mm).

46SV SERIES – 60Hz, 1750 RPM ODP/TEFC Enclosures

Pump Type Stages	Motor				Dimensions (in)										Weight (lbs.)												
	HP	NEMA Frame			L1	L2				M (Ref.)	D1 (max.)				D2	Pump Only	Motor				Pump/Motor						
		ODP 1Ø	TEFC 1Ø	ODP 3Ø		TEFC 3Ø	ODP 1Ø	TEFC 1Ø	ODP 3Ø		TEFC 3Ø	ODP 1Ø	TEFC 1Ø	ODP 3Ø			TEFC 3Ø	ODP 1Ø	TEFC 1Ø	ODP 3Ø	TEFC 3Ø	ODP 1Ø	TEFC 1Ø	ODP 3Ø	TEFC 3Ø		
46SV-1	1.5	-	-		22.19	-	-								147												
46SV-2/2	2	-	-	CONTACT FACTORY	25.19	-	-								158												
46SV-2/1		-	-		25.19	-	-								158												
46SV-2		-	-		25.19	-	-									158											
46SV-3/2		-	-			27.12	-	-	13.94	15.44	6.88	-	-	8.50	8.50	5.51	169	-	-	61	62	-	-	230	231		
46SV-3/1	3	-	-	182TC	27.12	-	-	13.94	15.44	6.88	-	-	8.50	8.50	5.51	169	-	-	61	62	-	-	230	231			
46SV-3		-	-		27.12	-	-	13.94	15.44	6.88	-	-	8.50	8.50	5.51	169	-	-	61	62	-	-	230	231			
46SV-4/2		-	-		31.63	-	-	13.94	15.44	6.88	-	-	8.50	8.50	5.51	192	-	-	68	75	-	-	260	267			
46SV-4/1	5	-	-	184TC	31.63	-	-	13.94	15.44	6.88	-	-	8.50	8.50	5.51	192	-	-	68	75	-	-	260	267			
46SV-4		-	-		31.63	-	-	13.94	15.44	6.88	-	-	8.50	8.50	5.51	192	-	-	68	75	-	-	260	267			
46SV-5/2		-	-		35.56	-	-	13.94	15.44	6.88	-	-	8.50	8.50	5.51	199	-	-	68	75	-	-	267	274			
46SV-5/1		-	-		35.56	-	-	13.94	15.44	6.88	-	-	8.50	8.50	5.51	199	-	-	68	75	-	-	267	274			
46SV-5	-	-	35.56	-	-	13.94	15.44	6.88	-	-	8.50	8.50	5.51	199	-	-	68	75	-	-	267	274					
46SV-6/2	7.5	-	-	213TC	37.50	-	-	15.56	15.50	8.06	-	-	10.19	10.25	5.51	208	-	-	68	75	-	-	276	283			
46SV-6/1		-	-		37.50	-	-	15.56	15.50	8.06	-	-	10.19	10.25	5.51	208	-	-	122	125	-	-	330	333			
46SV-6		-	-		37.50	-	-	15.56	15.50	8.06	-	-	10.19	10.25	5.51	208	-	-	122	125	-	-	330	333			
46SV-7/2		-	-		39.94	-	-	15.56	15.50	8.06	-	-	10.19	10.25	5.51	233	-	-	122	125	-	-	355	358			
46SV-7/1		-	-		39.94	-	-	15.56	15.50	8.06	-	-	10.19	10.25	5.51	233	-	-	122	125	-	-	355	358			
46SV-7		-	-		39.94	-	-	15.56	15.50	8.06	-	-	10.19	10.25	5.51	233	-	-	122	125	-	-	355	358			
46SV-8/2		-	-		42.94	-	-	15.56	15.50	8.06	-	-	10.19	10.25	5.51	242	-	-	122	125	-	-	364	367			
46SV-8/1		-	-		42.94	-	-	15.56	15.50	8.06	-	-	10.19	10.25	5.51	242	-	-	122	125	-	-	364	367			
46SV-8		-	-		42.94	-	-	15.56	15.50	8.06	-	-	10.19	10.25	5.51	242	-	-	122	125	-	-	364	367			
46SV-9/2		10	-		-	215TC	45.88	-	-	15.56	15.50	8.06	-	-	10.19	10.25	5.51	253	-	-	125	129	-	-	378	382	
46SV-9/1	-		-	45.88	-		-	15.56	15.50	8.06	-	-	10.19	10.25	5.51	253	-	-	125	129	-	-	378	382			
46SV-9	-		-	45.88	-		-	15.56	15.50	8.06	-	-	10.19	10.25	5.51	253	-	-	125	129	-	-	378	382			
46SV-10/2	-		-	48.12	-		-	15.56	15.50	8.06	-	-	10.19	10.25	5.51	164	-	-	125	129	-	-	289	293			

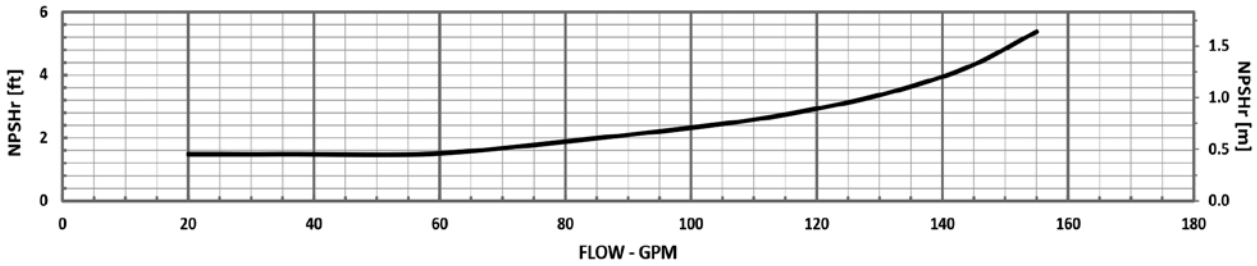
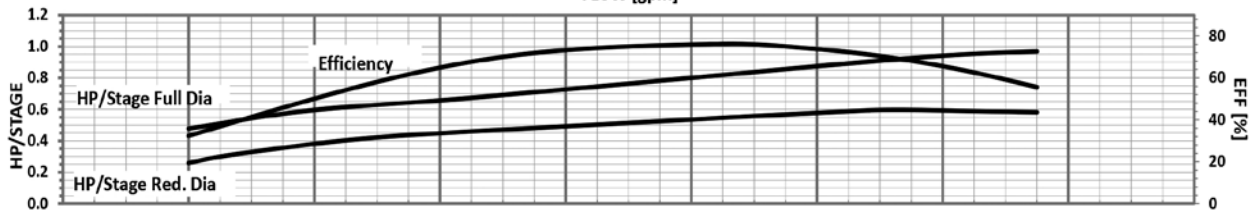
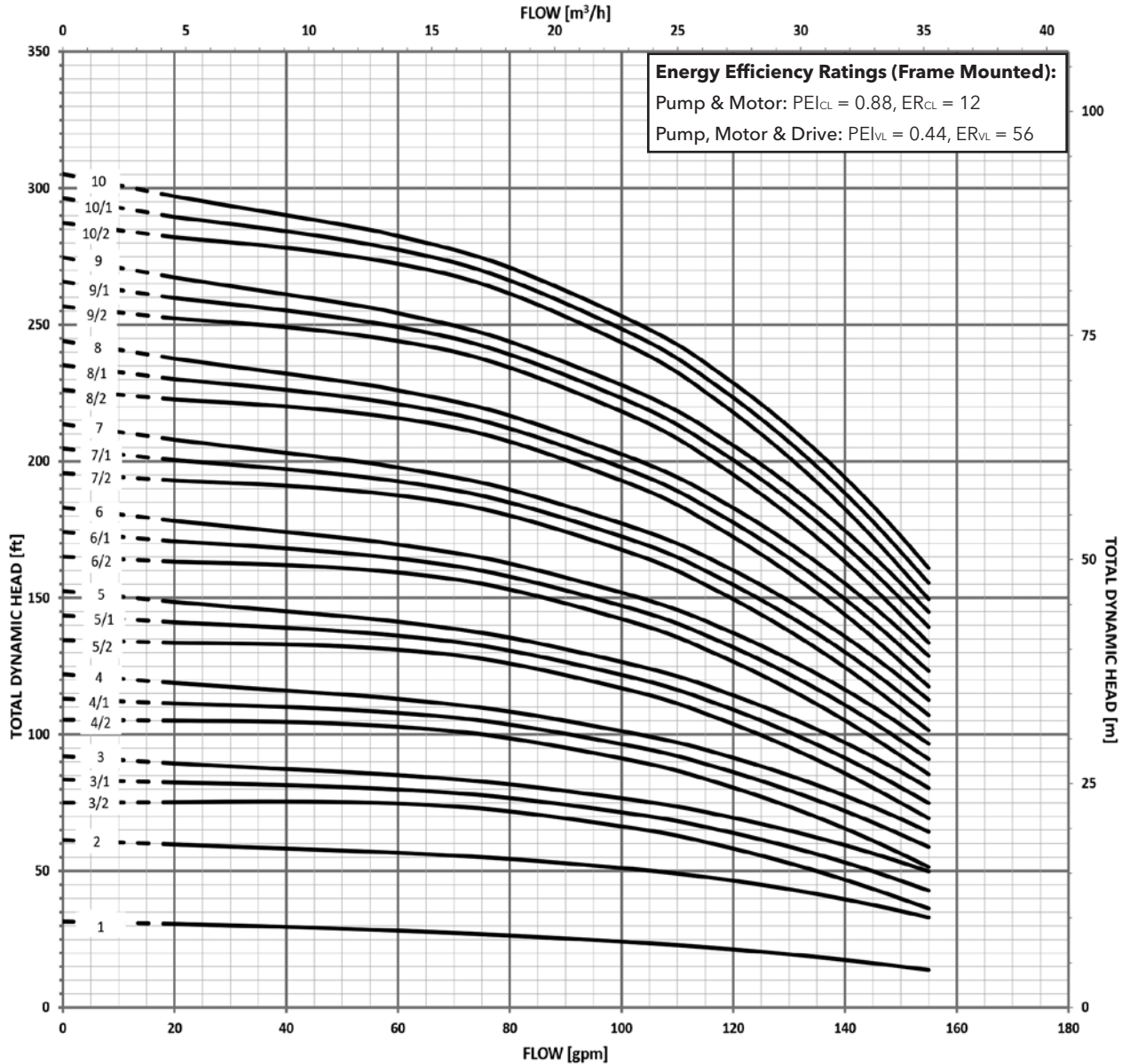

MINIMUM FLOW RATE: 20 GPM [5 m³/hr]

Commercial Water

Dimensions and Weights

66SV Series 1750 RPM

60 Hz

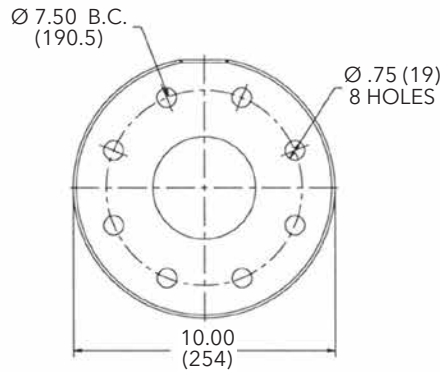
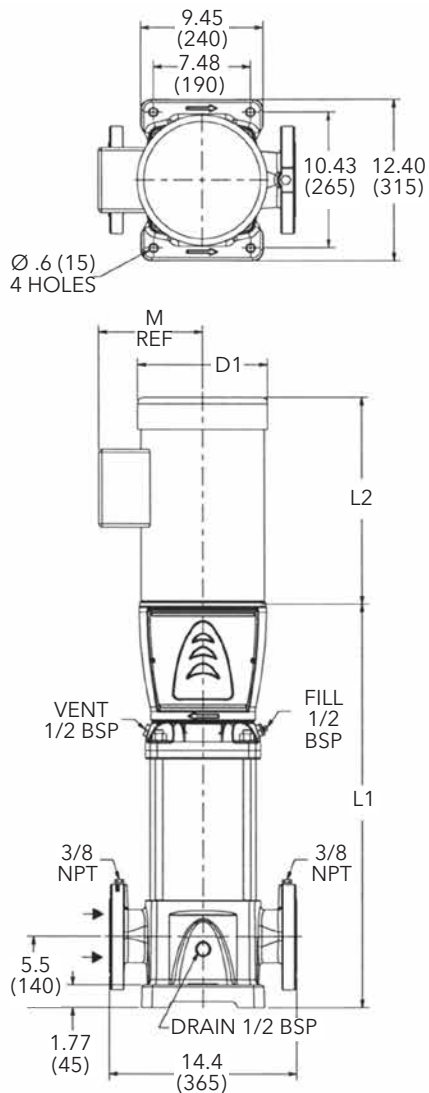

**Cast Iron
4\"/>**

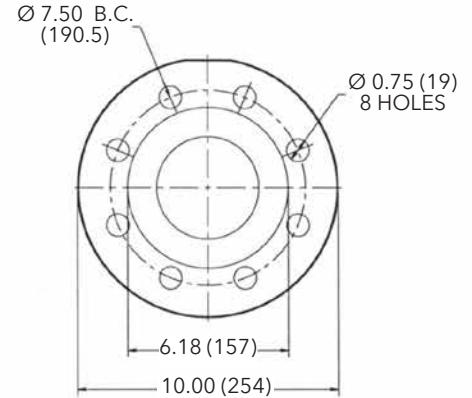

**316SS
4\"/>**

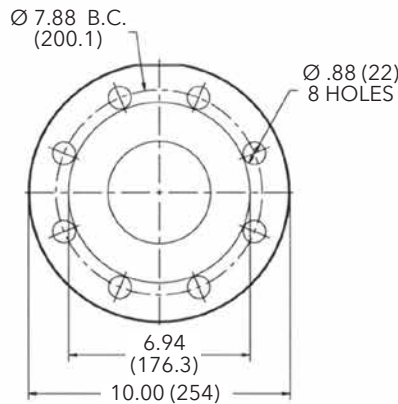

**Cast Iron
4\"/>**

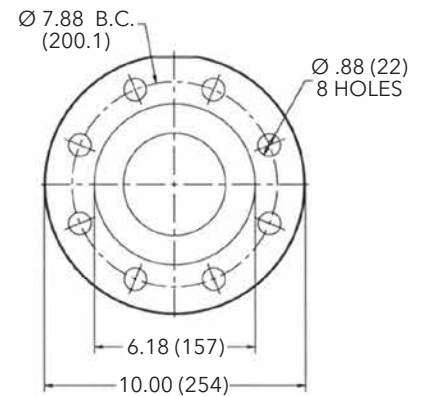

**316SS
4\"/>**

All dimensions are in inches (mm).

66SV SERIES – 60Hz, 1750 RPM ODP/TEFC Enclosures

Pump Type Stages	Motor				L1	Dimensions (in)								Pump Only	Weight (lbs.)									
	HP	NEMA Frame				L2				M (Ref.)	D1 (max.)				D2	Motor				Pump/Motor				
		ODP 1Ø	TEFC 1Ø	ODP 3Ø		TEFC 3Ø	ODP 1Ø	TEFC 1Ø	ODP 3Ø		TEFC 3Ø	ODP 1Ø	TEFC 1Ø			ODP 3Ø	TEFC 3Ø	ODP 1Ø	TEFC 1Ø	ODP 3Ø	TEFC 3Ø			
66SV-1	CONTACT FACTORY				23.19	CONTACT FACTORY				CONTACT FACTORY				185	CONTACT FACTORY									
66SV-2/2	3	-	-	182TC	26.75	-	-	13.94	15.44	6.88	-	-	8.50	8.50	5.51	196	-	-	61	62	-	-	257	258
66SV-2/1		-	-		26.75	-	-	13.94	15.44	6.88	-	-	8.50	8.50	5.51	196	-	-	61	62	-	-	257	258
66SV-2		-	-		26.75	-	-	13.94	15.44	6.88	-	-	8.50	8.50	5.51	196	-	-	61	62	-	-	257	258
66SV-3/2	5	-	-	184TC	30.81	-	-	13.94	15.44	6.88	-	-	8.50	8.50	5.51	223	-	-	68	75	-	-	291	298
66SV-3/1		-	-		30.81	-	-	13.94	15.44	6.88	-	-	8.50	8.50	5.51	223	-	-	68	75	-	-	291	298
66SV-3		-	-		30.81	-	-	13.94	15.44	6.88	-	-	8.50	8.50	5.51	223	-	-	68	75	-	-	291	298
66SV-4/2	7.5	-	-	213TC	34.38	-	-	13.94	15.44	6.88	-	-	8.50	8.50	5.51	234	-	-	68	75	-	-	302	309
66SV-4/1		-	-		34.38	-	-	13.94	15.44	6.88	-	-	8.50	8.50	5.51	234	-	-	68	75	-	-	302	309
66SV-4		-	-		34.38	-	-	15.56	15.50	8.06	-	-	10.19	10.25	5.51	234	-	-	122	125	-	-	356	359
66SV-5/2	-	-	37.44	-	-	15.56	15.50	8.06	-	-	10.19	10.25	5.51	252	-	-	122	125	-	-	374	377		
66SV-5/1	-	-	37.44	-	-	15.56	15.50	8.06	-	-	10.19	10.25	5.51	252	-	-	122	125	-	-	374	377		
66SV-5	-	-	37.44	-	-	15.56	15.50	8.06	-	-	10.19	10.25	5.51	252	-	-	122	125	-	-	374	377		
66SV-6/2	-	-	40.94	-	-	15.56	15.50	8.06	-	-	10.19	10.25	5.51	266	-	-	122	125	-	-	388	391		
66SV-6/1	10	-	-	215TC	40.94	-	-	15.56	15.50	8.06	-	-	10.19	10.25	5.51	266	-	-	125	129	-	-	391	395
66SV-6		-	-		40.94	-	-	15.56	15.50	8.06	-	-	10.19	10.25	5.51	266	-	-	125	129	-	-	391	395

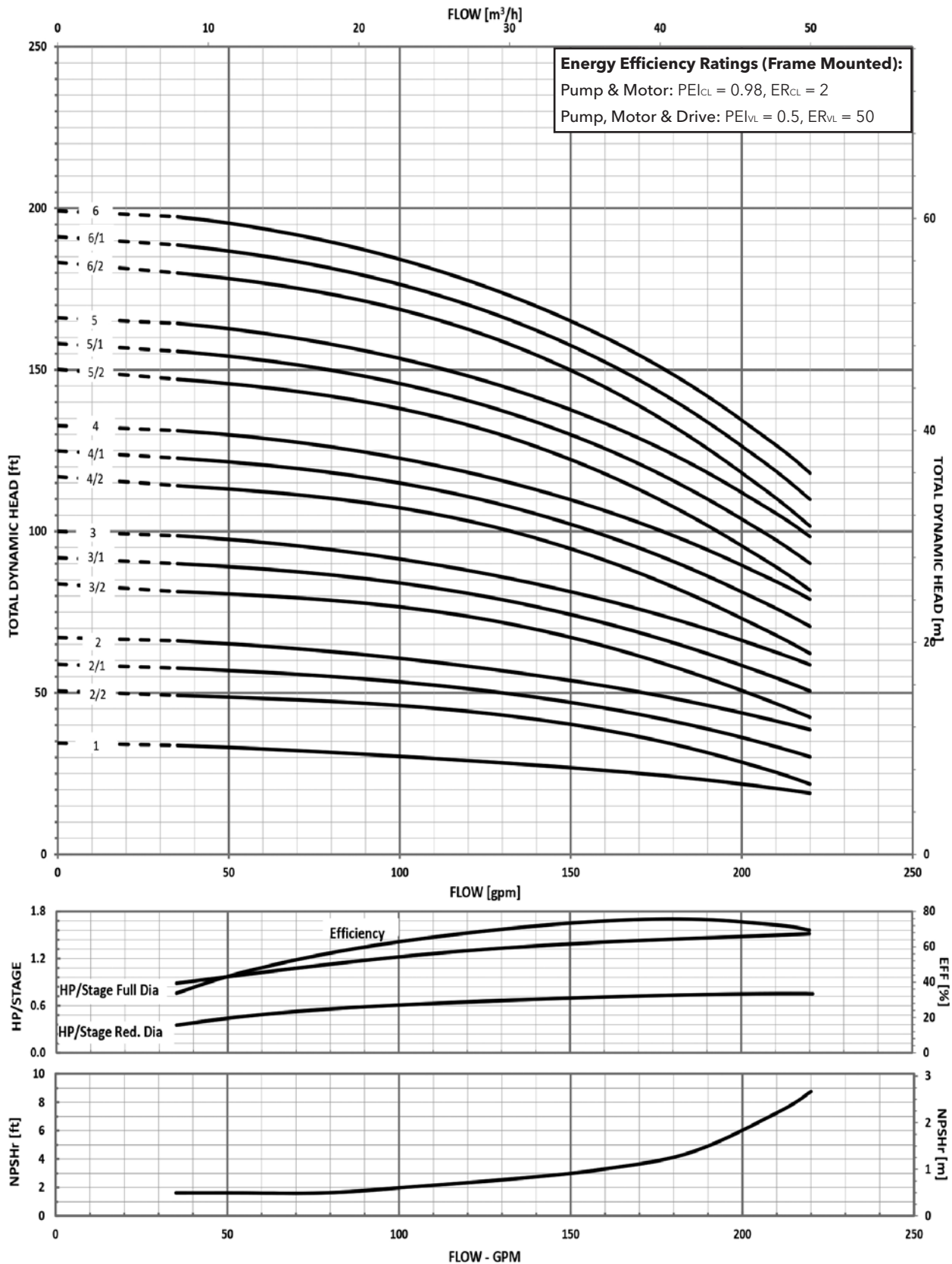

MINIMUM FLOW RATE: 35 GPM [8 m³/hr]

Commercial Water

Dimensions and Weights

92SV Series 1750 RPM

60 Hz

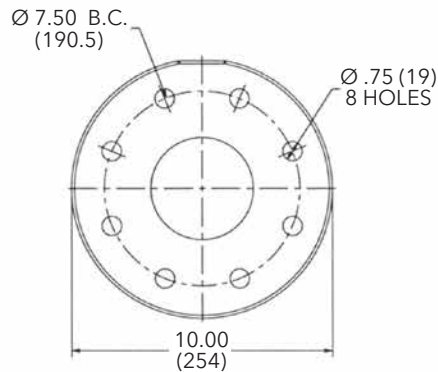
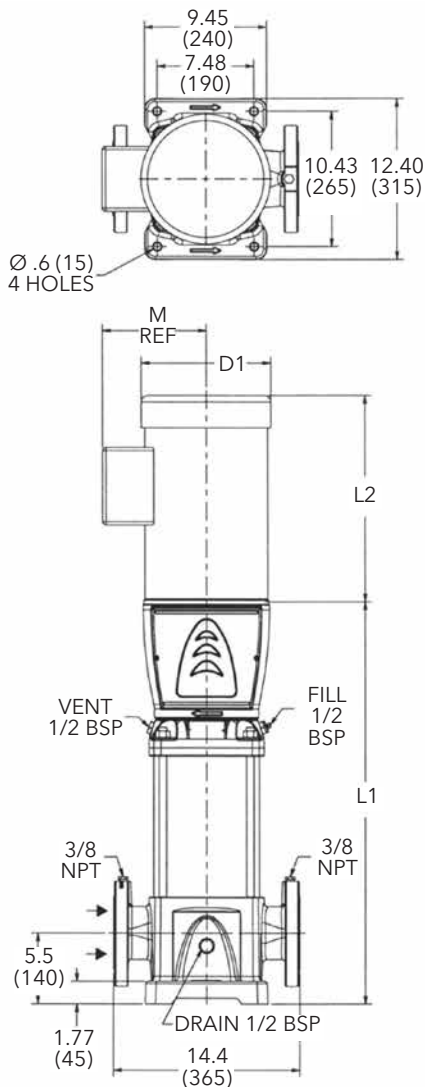

Cast Iron
4\"/>

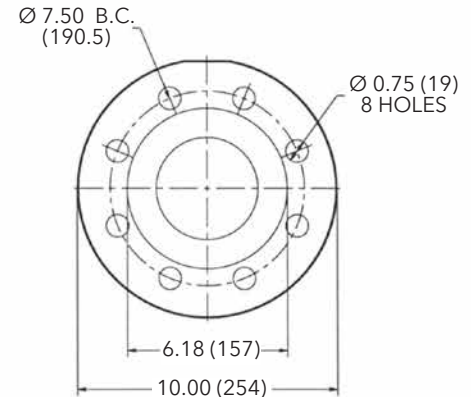

316SS
4\"/>

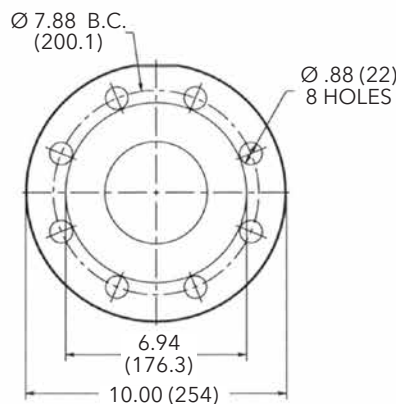

Cast Iron
4\"/>

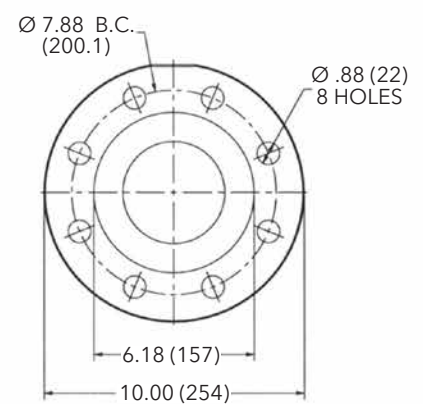

316SS
4\"/>

All dimensions are in inches (mm).

92SV SERIES – 60Hz, 1750 RPM ODP/TEFC Enclosures

Pump Type Stages	Motor				Dimensions (in)											Weight (lbs.)								
	HP	NEMA Frame			L1	L2				M (Ref.)	D1 (max.)				D2	Pump Only	Motor				Pump/Motor			
		ODP 10	TEFC 10	ODP 30		TEFC 30	ODP 10	TEFC 10	ODP 30		TEFC 30	ODP 10	TEFC 10	ODP 30			TEFC 30	ODP 10	TEFC 10	ODP 30	TEFC 30	ODP 10	TEFC 10	ODP 30
92SV-1	3	-	-	182TC	23.19	-	-	15.56	16.56	9.25	-	-	10.19	10.31	5.51	185	-	-	61	62	-	-	246	247
92SV-2/2		-	-		26.75	-	-	15.56	16.56	9.25	-	-	10.19	10.31	5.51	196	-	-	61	62	-	-	257	258
92SV-2/1	5	-	-	184TC	26.75	-	-	15.56	16.56	9.25	-	-	10.19	10.31	5.51	196	-	-	61	62	-	-	257	258
92SV-2		-	-		26.75	-	-	15.56	16.56	9.25	-	-	10.19	10.31	5.51	196	-	-	68	75	-	-	264	271
92SV-3/2		-	-		30.81	-	-	15.56	16.56	9.25	-	-	10.19	10.31	5.51	223	-	-	68	75	-	-	291	298
92SV-3/1		-	-		30.81	-	-	15.56	16.56	9.25	-	-	10.19	10.31	5.51	223	-	-	68	75	-	-	291	298
92SV-3		-	-		30.81	-	-	15.56	16.56	9.25	-	-	10.19	10.31	5.51	223	-	-	68	75	-	-	291	298
92SV-4/2		-	-		34.38	-	-	15.56	15.50	8.06	-	-	10.19	10.25	5.51	234	-	-	122	125	-	-	356	359
92SV-4/1	7.5	-	-	213TC	34.38	-	-	15.56	15.50	8.06	-	-	10.19	10.25	5.51	234	-	-	122	125	-	-	356	359
92SV-4		-	-		34.38	-	-	15.56	15.50	8.06	-	-	10.19	10.25	5.51	234	-	-	122	125	-	-	356	359
92SV-5/2		-	-		37.44	-	-	15.56	15.50	8.06	-	-	10.19	10.25	5.51	252	-	-	122	125	-	-	374	377
92SV-5/1		-	-		37.44	-	-	15.56	15.50	8.06	-	-	10.19	10.25	5.51	252	-	-	125	129	-	-	377	381
92SV-5	-	-	37.44	-	-	15.56	15.50	8.06	-	-	10.19	10.25	5.51	252	-	-	125	129	-	-	377	381		
92SV-6/2	10	-	-	215TC	40.94	-	-	15.56	15.50	8.06	-	-	10.19	10.25	5.51	266	-	-	125	129	-	-	391	395
92SV-6/1		-	-		40.94	-	-	15.56	15.50	8.06	-	-	10.19	10.25	5.51	266	-	-	125	129	-	-	391	395
92SV-6		-	-		40.94	-	-	15.56	15.50	8.06	-	-	10.19	10.25	5.51	266	-	-	125	129	-	-	391	395
92SV-6		-	-		40.94	-	-	15.56	15.50	8.06	-	-	10.19	10.25	5.51	266	-	-	125	129	-	-	391	395

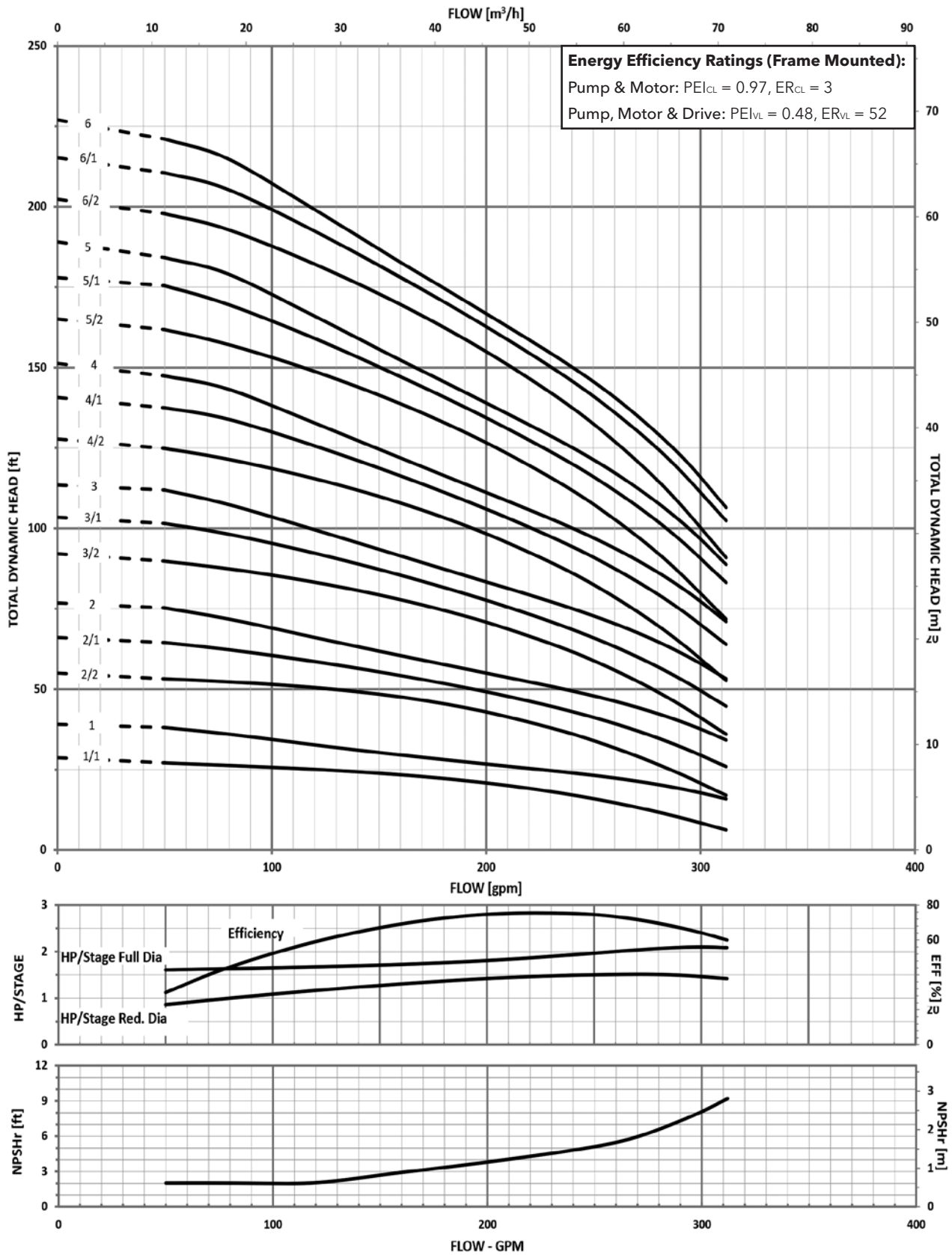

MINIMUM FLOW RATE: 50 GPM [11 m³/hr]

Commercial Water

Dimensions and Weights

125SV Series 1750 RPM

60 Hz

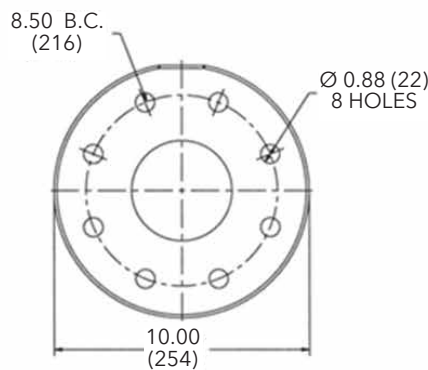
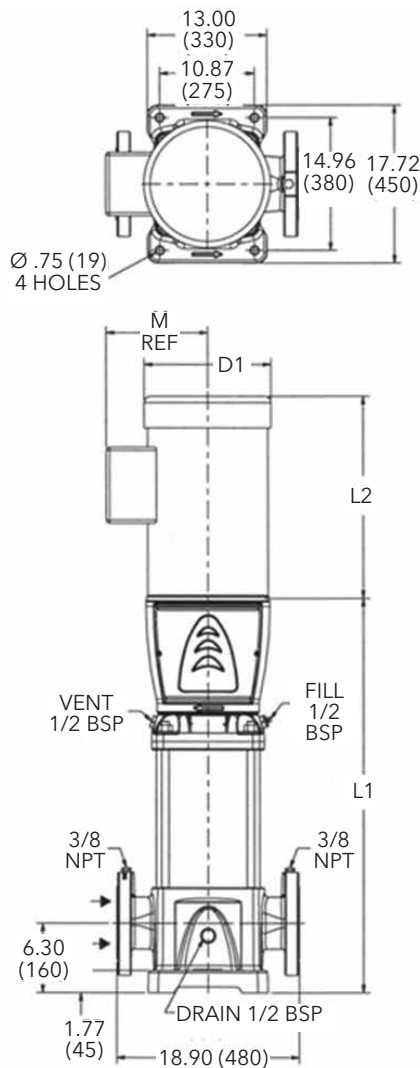

**Cast Iron
5" Class 125 F.F.**

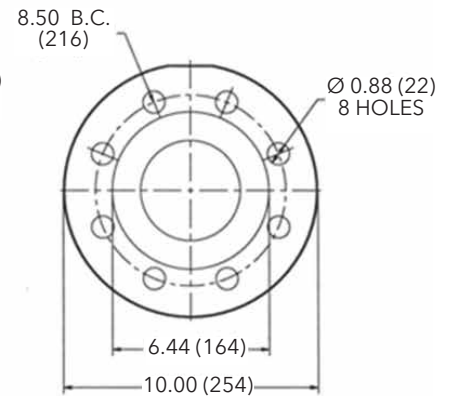

**316SS
5" Class 150 R.F.**

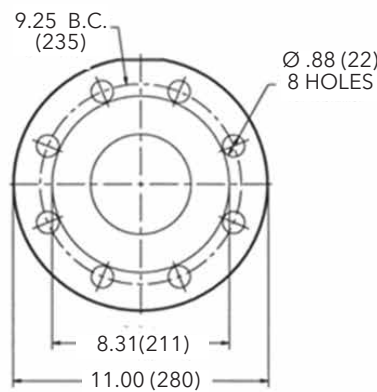

**Cast Iron
5" Class 250 R.F.**

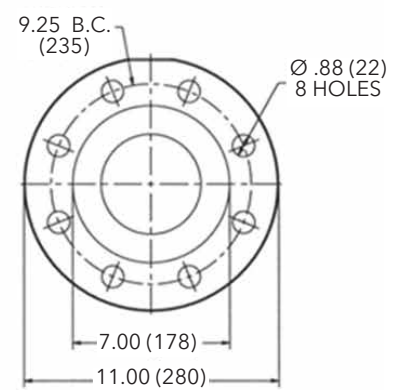

**316SS
5" Class 300 R.F.**

All dimensions are in inches (mm).

125SV SERIES – 60Hz, 1750 RPM ODP/TEFC Enclosures

Pump Type	HP	Motor				Dimensions (in)													Weight (lbs.)										
		NEMA Frame				L2				D1 (max.)					Motor				Pump/Motor										
		ODP 1Ø	TEFC 1Ø	ODP 3Ø	TEFC 3Ø	L1	ODP 1Ø	TEFC 1Ø	ODP 3Ø	TEFC 3Ø	L3	L4	L5	L6	M (Ref.)	ODP 1Ø	TEFC 1Ø	ODP 3Ø	TEFC 3Ø	D2	Pump	ODP 1Ø	TEFC 1Ø	ODP 3Ø	TEFC 3Ø	ODP 1Ø	TEFC 1Ø	ODP 3Ø	TEFC 3Ø
125SV2OC	5	184TC	184TC	182TC	184TC	34.60	13.93	15.43	12.55	13.93	-	-	-	-	6.87	8.88	8.86	9.02	8.86	5.51	289	81	92	62	69	370	381	351	358
125SV3/3A	5	184TC	184TC	182TC	184TC	40.50	13.93	15.43	12.55	13.93	-	-	-	-	6.87	8.88	8.86	9.02	8.86	5.51	315	81	92	62	69	396	407	377	384
125SV4OC	7.5	213TC	213TC	184TC	184TC	46.40	13.88	15.53	13.93	15.43	-	-	-	-	8.05	8.89	10.62	8.88	8.86	5.51	355	100	120	75	85	455	475	430	440
125SV5/5A	10	215TC	215TC	213TC	215TC	52.30	16.63	16.68	15.55	15.51	-	-	-	-	8.77	10.62	10.18	10.18	10.28	5.51	379	132	145	107	122	511	524	486	501
125SV6/6A	10	215TC	215TC	213TC	215TC	58.20	16.63	16.68	15.55	15.51	-	-	-	-	8.77	10.62	10.18	10.18	10.28	5.51	412	132	145	107	122	544	557	519	534
125SV7OC	15	-	-	215TC	254TC	65.30	-	-	15.55	16.57	-	-	-	-	9.22	-	-	10.18	10.28	5.51	476	-	-	125	195	-	-	601	671
125SV8OC	15	-	-	215TC	254TC	71.10	-	-	15.55	16.57	-	-	-	-	9.22	-	-	10.18	10.28	5.51	494	-	-	125	195	-	-	619	689

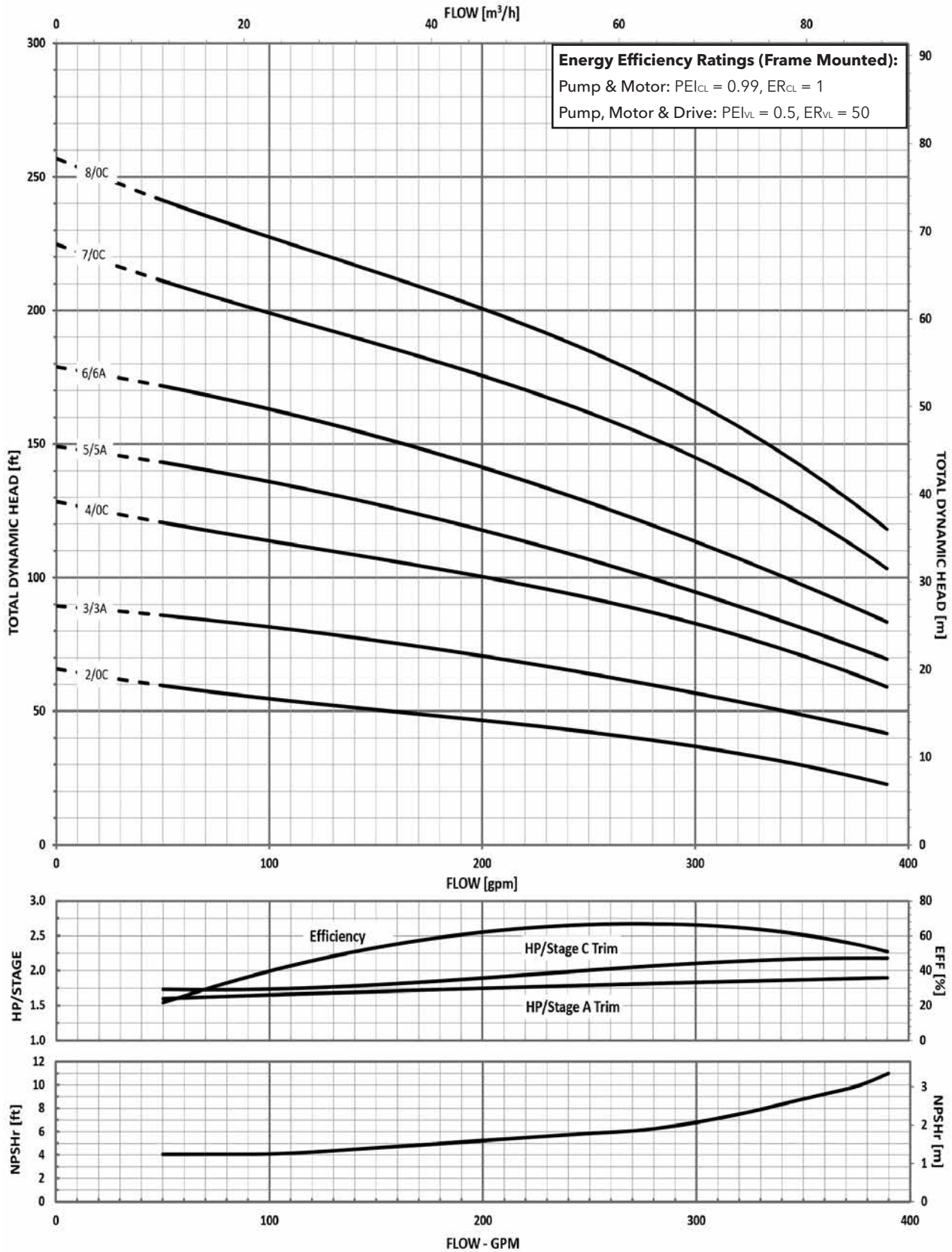

MINIMUM FLOW RATE: 50 GPM [10 m³/hr]

Commercial Water

1SV - 22SV Horizontal Mounting Option

- Consists of e-SV pump with base mounting foot and footed motor for horizontal installations.
- Unit depicted may not show actual pump configuration. Use for mounting location only.

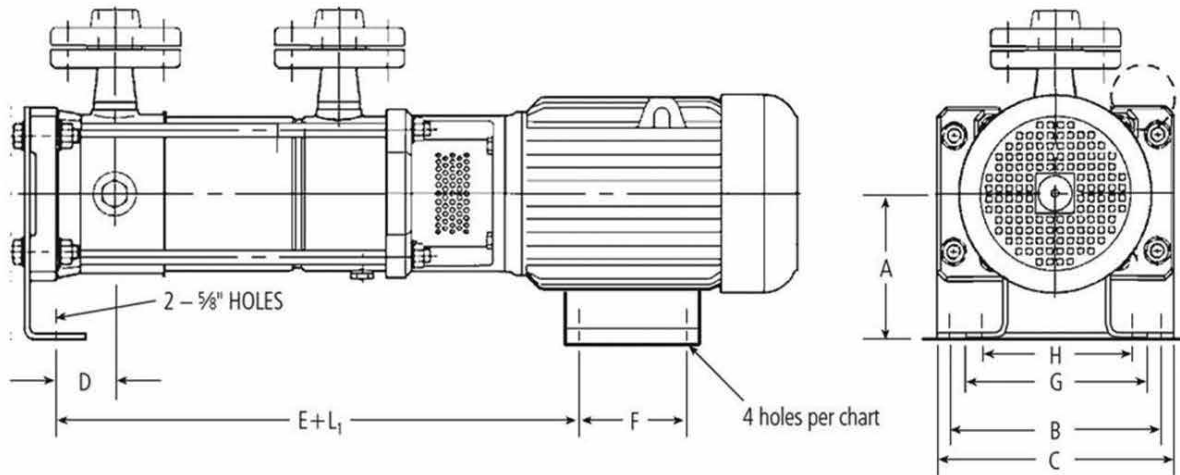

Flanges can be rotated 90° left or right.

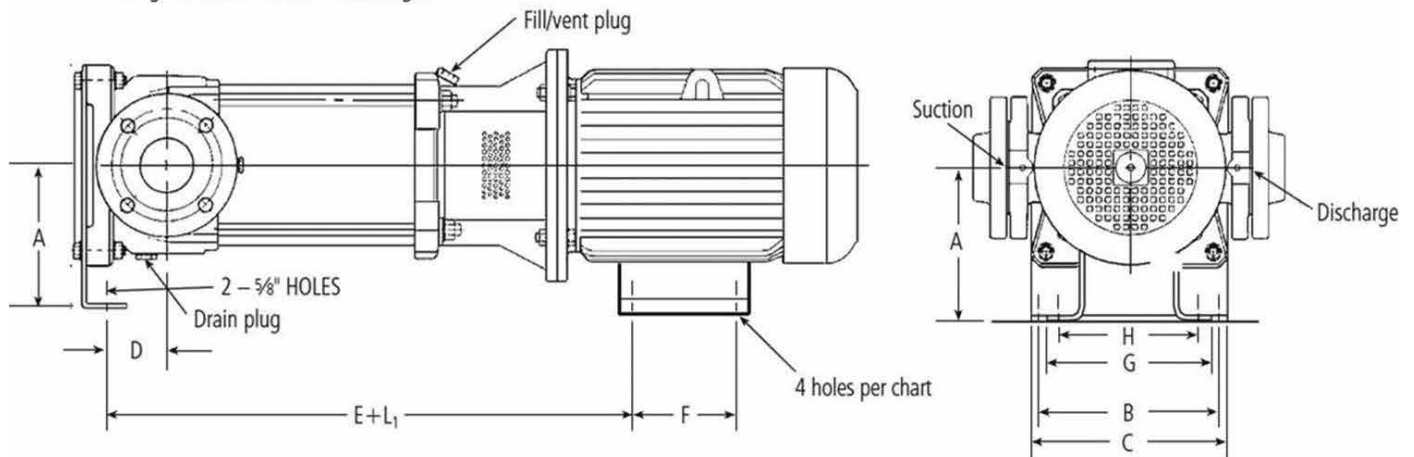

15V - 22SV HORIZONTAL MOUNTING OPTION

Series	Motor Frame	Flange	A	B	C	D	E	F	G	H	Motor Shim Thickness	Pump Shim Thickness
15V	56C	T	4.5	7	9	0.219	0.810	3	6.563	4.825	1	-
		F, N, P, G, C	4.5	7	9	1.125	0.810	3	6.563	4.825	1	-
		R	4.5	11	12	1.254	0.940	3	6.563	4.825	1	-
35V	56C	T	4.5	7	9	0.219	0.81	3	6.563	4.825	1	-
		F, N, P, G, C	4.5	7	9	1.125	0.81	3	6.563	4.825	1	-
		R	4.5	11	12	1.254	0.94	3	6.563	4.825	1	-
	180TC	T	4.5	7	9	0.219	1.88	5.5	6.563	4.825	-	-
		F, N, P, G, C	4.5	7	9	1.125	1.88	5.5	6.563	4.825	-	-
		R	4.5	11	12	1.254	2.01	5.5	6.563	4.825	-	-
	210TC	T	4.5	7	9	0.219	2.5	7	6.563	4.825	-	0.75
		F, N, P, G, C	4.5	7	9	1.125	2.5	7	6.563	4.825	-	0.75
		R	4.5	11	12	1.254	2.63	7	6.563	4.825	-	0.75
55V	56C	T	4.5	7	9	0.219	0.81	3	6.563	4.825	1	-
		F, N, P, G, C	4.5	7	9	1.125	0.81	3	6.563	4.825	1	-
		R	4.5	11	12	1.254	0.94	3	6.563	4.825	1	-
	180TC	T	4.5	7	9	0.219	1.88	5.5	6.563	4.825	-	-
		F, N, P, G, C	4.5	7	9	1.125	1.88	5.5	6.563	4.825	-	-
		R	4.5	11	12	1.254	2.01	5.5	6.563	4.825	-	-
	210TC	T	4.5	7	9	0.219	2.5	7	6.563	4.825	-	0.75
		F, N, P, G, C	4.5	7	9	1.125	2.5	7	6.563	4.825	-	0.75
		R	4.5	11	12	1.254	2.63	7	6.563	4.825	-	0.75
105V	56C	T	6.25	9.125	10.50	1.59	1	3	6.563	4.825	2.75	-
		F, N, P, G, C	6.25	9.125	10.50	1.983	1	3	6.563	4.825	2.75	-
		R	6.25	11.875	13.25	1.983	1	3	6.563	4.825	1	-
	180TC	T	6.25	9.125	10.50	1.59	2.07	5.5	8.625	7.50	1.75	-
		F, N, P, G, C	6.25	9.125	10.50	1.983	2.07	5.5	8.625	7.50	1.75	-
		R	6.25	11.875	13.25	1.983	2.07	5.5	8.625	7.50	-	-
	210TC	T	6.25	9.125	10.50	1.59	2.69	7	9.500	8.50	1	-
		F, N, P, G, C	6.25	9.125	10.50	1.983	2.69	7	9.500	8.50	1	-
		R	6.25	11.875	13.25	1.983	2.69	7	9.500	8.50	-	0.75
	250TC	T	6.25	9.125	10.50	1.59	3.19	10	11.500	10.00	-	-
		F, N, P, G, C	6.25	9.125	10.50	1.983	3.19	10	11.500	10.00	-	-
		R	6.25	11.875	13.25	1.983	3.19	10	11.500	10.00	-	1.75
155V	56C	T	6.25	9.125	10.50	1.59	1	3	6.563	4.825	2.75	-
		F, N, P, G, C	6.25	9.125	10.50	1.983	1	3	6.563	4.825	2.75	-
		R	6.25	11.875	13.25	1.983	1	3	6.563	4.825	1	-
	180TC	T	6.25	9.125	10.50	1.59	2.07	5.5	8.625	7.50	1.75	-
		F, N, P, G, C	6.25	9.125	10.50	1.983	2.07	5.5	8.625	7.50	1.75	-
		R	6.25	11.875	13.25	1.983	2.07	5.5	8.625	7.50	-	-
	210TC	T	6.25	9.125	10.50	1.59	2.69	7	9.500	8.50	1	-
		F, N, P, G, C	6.25	9.125	10.50	1.983	2.69	7	9.500	8.50	1	-
		R	6.25	11.875	13.25	1.983	2.69	7	9.500	8.50	-	0.75
	250TC	T	6.25	9.125	10.50	1.59	3.19	10	11.500	10.00	-	-
		F, N, P, G, C	6.25	9.125	10.50	1.983	3.19	10	11.500	10.00	-	-
		R	6.25	11.875	13.25	1.983	3.19	10	11.500	10.00	-	1.75
280TC	T	6.25	9.125	10.50	1.59	3.19	11	12.750	12.50	-	0.75	
	F, N, P, G, C	6.25	9.125	10.50	1.983	3.19	11	12.750	12.50	-	0.75	
	R	6.25	11.875	13.25	1.983	3.19	11	12.750	12.50	-	2.50	
225V	56C	T	6.25	9.125	10.50	1.59	1	3	6.563	4.825	2.75	-
		F, N, P, G, C	6.25	9.125	10.50	1.983	1	3	6.563	4.825	2.75	-
		R	6.25	11.875	13.25	1.983	1	3	6.563	4.825	1	-
	180TC	T	6.25	9.125	10.50	1.59	2.07	5.5	8.625	7.50	1.75	-
		F, N, P, G, C	6.25	9.125	10.50	1.983	2.07	5.5	8.625	7.50	1.75	-
		R	6.25	11.875	13.25	1.983	2.07	5.5	8.625	7.50	-	-
	210TC	T	6.25	9.125	10.50	1.59	2.69	7	9.500	8.50	1	-
		F, N, P, G, C	6.25	9.125	10.50	1.983	2.69	7	9.500	8.50	1	-
		R	6.25	11.875	13.25	1.983	2.69	7	9.500	8.50	-	0.75
	250TC	T	6.25	9.125	10.50	1.59	3.19	10	11.500	10.00	-	-
		F, N, P, G, C	6.25	9.125	10.50	1.983	3.19	10	11.500	10.00	-	-
		R	6.25	11.875	13.25	1.983	3.19	10	11.500	10.00	-	1.75
280TC	T	6.25	9.125	10.50	1.59	3.19	11	12.750	12.50	-	0.75	
	F, N, P, G, C	6.25	9.125	10.50	1.983	3.19	11	12.750	12.50	-	0.75	
	R	6.25	11.875	13.25	1.983	3.19	11	12.750	12.50	-	2.50	

Commercial Water

33SV - 92SV HORIZONTAL MOUNTING OPTION

- Consists of e-SV pump with base mounting foot and footed motor for horizontal installations.
- Unit depicted may not show actual pump configuration. Use for mounting location only.

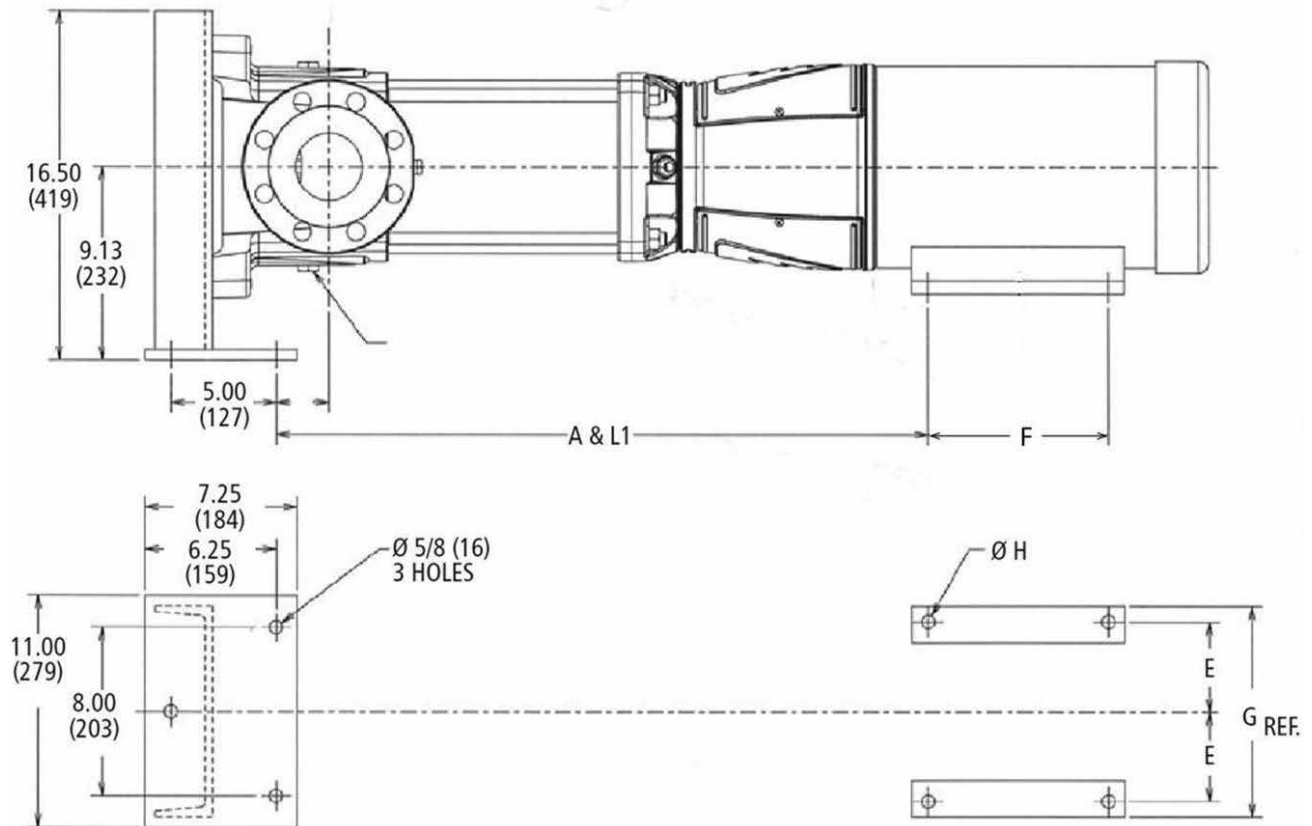

Series	Motor Frame	Flange	A	B	E	F	G	H - DIA.
33SV	182TC	G, N	0.5	1.13	3.5	2.25	8.63	13/32
	184TC					2.75		
	213TC		1.25		4.25	2.75	9.5	
	215TC					3.5		
	254TC		1.75		5	4.12	11.25	17/32
	256TC					5		
	284TC		1.75		5.5	4.75	12.25	
	286TC					5.5		
	324TSC		2.25		6.25	5.25	16	21/32
	326TSC					6		
	364TSC		2.88		7	5.63	18	
365TSC	6.12							
46/66/92SV	182TC	G, N	0.5	2.5	3.7	2.25	8.63	13/32
	184TC					2.75		
	213TC		1.25		4.25	2.75	9.5	
	215TC					3.5		
	254TC		1.75		5	4.12	11.25	17/32
	256TC					5		
	284TC		1.75		5.5	4.75	16.5	
	286TC					5.5		
	324TSC		2.25		6.25	5.25	15.25	21/32
	326TSC					6		
	364TSC		2.88		7	5.63	17	
	365TSC					6.12		

125SV HORIZONTAL MOUNTING OPTION

- Consists of e-SV pump with base mounting foot and footed motor for horizontal installations.
- Unit depicted may not show actual pump configuration. Use for mounting location only.

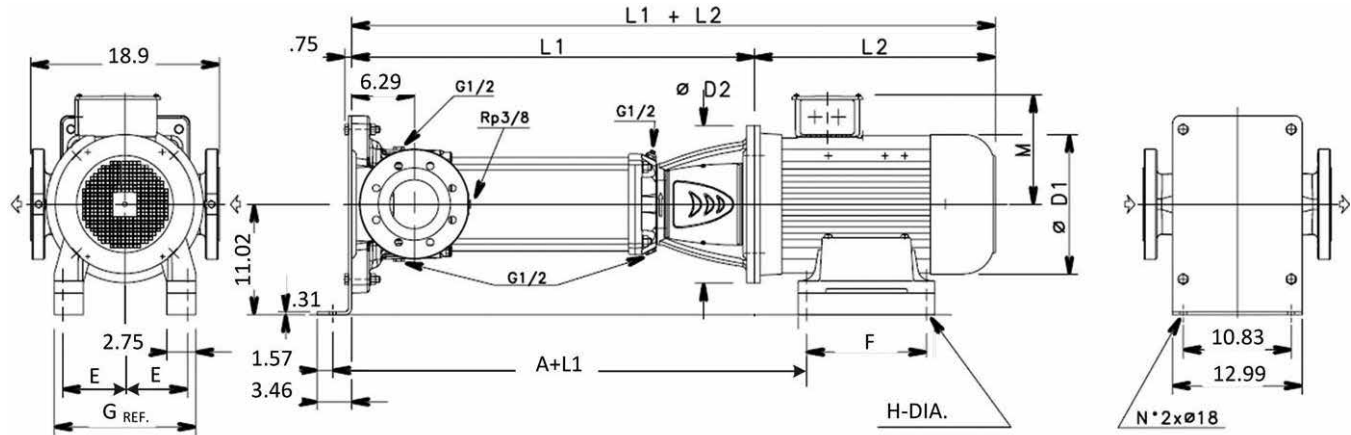

Series	Motor Frame	Flange	A	E	F	G (ref.)	H - Dia.
125SV	182TC	G, N	5.20	3.5	2.25	8.63	13/32
	184TC				2.75		
	213TC				2.75		
	215TC		3.5	9.5			
	254TC		4.12				
	256TC		5				
	284TC		4.75	11.25	17/32		
	286TC		5.5				
	324TSC		5.25	12.25	21/32		
	326TSC		6				
	364TSC		5.63				
	365TSC		6.12	16	18		
	7						

Commercial Water

Technical Data - Pump Hydraulics / Motor Sizing

1SV 3500 RPM

No. of Impellers	Maximum HP draw	Motor Selection using SF			Motor Selection 1.0 SF			Shutoff TDH (Feet)	Shutoff TDH (psi)	Shutoff TDH (Bar)	Casing/Sleeve Pressure Rating (standard assy.)	Pump Flange Rating		
		Rated HP	NEMA Motor Frame		Rated HP	NEMA Motor Frame								
			ODP	TEFC		ODP	TEFC							
30	3.45	3.00	56C	56C	5.00	184TC	184TC	860	372	25.7	40 Bar (580 psi)	Class 250 / 300		
29	3.34		56C	56C		184TC	184TC	835	362	24.9				
28	3.22		56C	56C		184TC	184TC	810	351	24.2				
27	3.11		56C	56C		184TC	184TC	780	338	23.3				
26	2.99		56C	56C		56C	56C	750	325	22.4				
25	2.88		56C	56C	56C	56C	720	312	21.5					
24	2.76		56C	56C	56C	56C	695	301	20.7					
23	2.67		56C	56C	56C	56C	665	288	19.8					
22	2.53		56C	56C	56C	56C	635	275	18.9					
21	2.42		56C	56C	56C	56C	610	264	18.2					
20	2.30	2.00	56C	56C	56C	56C	580	251	17.3	25 Bar (362 psi)	Class 250 / 300			
19	2.19		56C	56C	56C	56C	550	238	16.4					
18	2.07		56C	56C	56C	56C	520	225	15.5					
17	1.96		56C	56C	56C	56C	485	210	14.5					
16	1.84		56C	56C	56C	56C	455	197	13.6					
15	1.73	1.50	56C	56C	2.00	56C	56C	425	184			12.7	25 Bar (362 psi)	Class 250 / 300
14	1.61		56C	56C		56C	56C	400	173			11.9		
13	1.50		56C	56C		56C	56C	375	162			11.2		
12	1.38		56C	56C		56C	56C	345	149			10.3		
11	1.27		56C	56C		56C	56C	315	136			9.4		
10	1.15	1.00	56C	56C	1.50	56C	56C	290	126	8.7	25 Bar (362 psi)	Class 250 / 300		
9	1.04		56C	56C		56C	56C	255	110	7.6				
8	0.92		56C	56C		56C	56C	230	100	6.9				
7	0.81		56C	56C		56C	56C	200	87	6.0				
6	0.69		56C	56C		56C	56C	175	76	5.2				
5	0.58	0.50	56C	56C	0.75	56C	56C	145	63	4.3			25 Bar (362 psi)	Class 250 / 300
4	0.46		56C	56C		56C	56C	115	50	3.4				
3	0.35		56C	56C		56C	56C	85	37	2.5				
2	0.23		56C	56C		56C	56C	60	26	1.8				

3SV 3500 RPM

No. of Impellers	Maximum HP draw	Motor Selection using SF			Motor Selection 1.0 SF			Shutoff TDH (Feet)	Shutoff TDH (psi)	Shutoff TDH (Bar)	Casing/Sleeve Pressure Rating (standard assy.)	Pump Flange Rating				
		Rated HP	NEMA Motor Frame		Rated HP	NEMA Motor Frame										
			ODP	TEFC		ODP	TEFC									
30	6.24	7.50	213TC	213TC	7.50	213TC	213TC	1085	470	32.4	40 Bar (580 psi)	Class 250 / 300				
29	6.03		213TC	213TC		213TC	213TC	1050	455	31.3						
28	5.82		213TC	213TC		213TC	213TC	1015	440	30.3						
27	5.62		184TC	184TC		213TC	213TC	975	422	29.1						
26	5.41		184TC	184TC		213TC	213TC	940	407	28.0						
25	5.20		184TC	184TC	213TC	213TC	900	390	26.9							
24	4.99		184TC	184TC	184TC	184TC	865	375	25.8							
23	4.78		184TC	184TC	184TC	184TC	825	357	24.6							
22	4.58		184TC	184TC	184TC	184TC	795	344	23.7							
21	4.37		184TC	184TC	184TC	184TC	760	329	22.7							
20	4.16	5.00	184TC	184TC	5.00	184TC	184TC	720	312	21.5	25 Bar (362 psi)	Class 250 / 300				
19	3.95		184TC	184TC		184TC	184TC	680	294	20.3						
18	3.74		184TC	184TC		184TC	184TC	645	279	19.2						
17	3.54		184TC	184TC		184TC	184TC	610	264	18.2						
16	3.33		56C	56C		184TC	184TC	575	249	17.2						
15	3.12		56C	56C		184TC	184TC	540	234	16.1						
14	2.91		56C	56C		56C	56C	500	217	14.9						
13	2.70		56C	56C		56C	56C	465	201	13.9						
12	2.50		56C	56C		56C	56C	430	186	12.8						
11	2.29		3.00	56C		56C	3.00	56C	56C	395			171	11.8	25 Bar (362 psi)	Class 250 / 300
10	2.08	56C		56C	56C	56C		360	156	10.7						
9	1.87	56C		56C	56C	56C		320	139	9.5						
8	1.66	56C		56C	56C	56C		285	123	8.5						
7	1.46	2.00		56C	56C	2.00		56C	56C	250	108	7.5	25 Bar (362 psi)	Class 250 / 300		
6	1.25		56C	56C	56C		56C	215	93	6.4						
5	1.04		56C	56C	56C		56C	180	78	5.4						
4	0.83		56C	56C	1.00		56C	56C	145	63	4.3					
3	0.62		0.50	56C	56C		0.75	56C	56C	105	45	3.1				
2	0.42	56C		56C	0.50	56C		56C	70	30	2.1					

TECHNICAL DATA - PUMP HYDRAULICS / MOTOR SIZING

5SV 3500 RPM

No. of Impellers	Maximum HP draw	Motor Selection using SF				Motor Selection 1.0 SF				Shutoff TDH (Feet)	Shutoff TDH (psi)	Shutoff TDH (Bar)	Casing/Sleeve Pressure Rating (standard assy.)	Pump Flange Rating
		Rated HP	NEMA Motor Frame		Rated HP	NEMA Motor Frame								
			ODP	TEFC		ODP	TEFC							
27	8.80	10.00	215TC	215TC	10.00	215TC	215TC	975	422	29.1	40 Bar (580 psi)	Class 250 / 300		
26	8.48	7.50	213TC	213TC		215TC	215TC	940	407	28.0				
25	8.15		213TC	213TC		215TC	215TC	900	390	26.9				
24	7.82		213TC	213TC		215TC	215TC	865	375	25.8				
23	7.50		213TC	213TC	7.50	213TC	213TC	825	357	24.6				
22	7.17	213TC	213TC	213TC		213TC	785	340	23.4					
21	6.85	213TC	213TC	213TC		213TC	745	323	22.2					
20	6.52	213TC	213TC	213TC		213TC	715	310	21.3					
19	6.19	5.00	213TC	213TC	5.00	213TC	213TC	685	297	20.4				
18	5.87		213TC	213TC		213TC	213TC	650	282	19.4				
17	5.54		184TC	184TC		213TC	213TC	615	266	18.4				
16	5.22		184TC	184TC		213TC	213TC	575	249	17.2				
15	4.89	5.00	184TC	184TC	5.00	184TC	184TC	540	234	16.1				
14	4.56		184TC	184TC		184TC	184TC	505	219	15.1				
13	4.24		184TC	184TC		184TC	184TC	470	204	14.0				
12	3.91		184TC	184TC		184TC	184TC	430	186	12.8				
11	3.59	3.00	184TC	184TC	3.00	184TC	184TC	395	171	11.8				
10	3.26		56C	56C		56C	56C	360	156	10.7				
9	2.93		56C	56C		56C	56C	320	139	9.5				
8	2.61		56C	56C		56C	56C	285	123	8.5				
7	2.28	2.00	56C	56C	2.00	56C	56C	250	108	7.5				
6	1.96		56C	56C		56C	56C	220	95	6.6				
5	1.63	1.50	56C	56C	1.50	56C	56C	180	78	5.4				
4	1.30		56C	56C		56C	56C	145	63	4.3				
3	0.98	1.00	56C	56C	1.00	56C	56C	110	48	3.3				
2	0.65	0.75	56C	56C	0.75	56C	56C	70	30	2.1				

10SV 3500 RPM

No. of Impellers	Maximum HP draw	Motor Selection using SF				Motor Selection 1.0 SF				Shutoff TDH (Feet)	Shutoff TDH (psi)	Shutoff TDH (Bar)	Casing/Sleeve Pressure Rating (standard assy.)	Pump Flange Rating
		Rated HP	NEMA Motor Frame		Rated HP	NEMA Motor Frame								
			ODP	TEFC		ODP	TEFC							
20	17.84	20.00	254TC	256TC	20.00	254TC	256TC	1150	498	34.3	40 Bar (580 psi)	Victaulic		
19	16.95	15.00	215TC	254TC		254TC	256TC	1095	474	32.7				
18	16.06		215TC	254TC		254TC	256TC	1035	448	30.9				
17	15.16		215TC	254TC		254TC	256TC	975	422	29.1				
16	14.27		215TC	254TC	15.00	215TC	254TC	920	398	27.5				
15	13.38	215TC	254TC	215TC		254TC	860	372	25.7					
14	12.49	215TC	215TC	215TC		254TC	805	349	24.0					
13	11.60	215TC	215TC	215TC		254TC	745	323	22.2					
12	10.70	10.00	215TC	215TC	10.00	215TC	254TC	690	299	20.6				
11	9.81		215TC	215TC		215TC	215TC	630	273	18.8				
10	8.92		215TC	215TC		215TC	215TC	575	249	17.2				
9	8.03		213TC	213TC		215TC	215TC	520	225	15.5				
8	7.14	7.50	213TC	213TC	7.50	213TC	213TC	460	199	13.7				
7	6.24		213TC	213TC		213TC	213TC	400	173	11.9				
6	5.35	5.00	184TC	184TC	5.00	213TC	213TC	340	147	10.1				
5	4.46		184TC	184TC		184TC	184TC	285	123	8.5				
4	3.57		184TC	184TC		184TC	184TC	225	97	6.7				
3	2.68		3.00	56C		56C	3.00	56C	56C	170	74	5.1		
2	1.78	2.00	56C	56C	2.00	56C	56C	115	50	3.4				
1	0.89	0.75	56C	56C	1.00	56C	56C	60	26	1.8				

TECHNICAL DATA - PUMP HYDRAULICS / MOTOR SIZING

15SV 3500 RPM

No. of Impellers	Maximum HP draw	Motor Selection using SF				Motor Selection 1.0 SF				Shutoff TDH (Feet)	Shutoff TDH (psi)	Shutoff TDH (Bar)	Casing/Sleeve Pressure Rating (standard assy.)	Pump Flange Rating
		Rated HP	NEMA Motor Frame		Rated HP	NEMA Motor Frame								
			ODP	TEFC		ODP	TEFC							
15	28.50	25.00	254TC	284TC	30.00	284TC	286TC	1060	459	31.6	40 Bar (580 psi)	Class 250 / 300		
14	26.60		254TC	284TC		284TC	286TC	990	429	29.5				
13	24.70		254TC	284TC		254TC	284TC	915	396	27.3				
12	22.80	20.00	254TC	256TC	25.00	254TC	284TC	850	368	25.4				
11	20.90		254TC	256TC		254TC	284TC	780	338	23.3				
10	19.00		254TC	256TC		254TC	256TC	705	305	21.0				
9	17.10	15.00	215TC	254TC	20.00	254TC	256TC	635	275	18.9				
8	15.20		215TC	254TC		254TC	256TC	565	245	16.9				
7	13.30		215TC	254TC		15.00	215TC	254TC	485	210	14.5			
6	11.40	10.00	215TC	215TC	215TC		254TC	420	182	12.5				
5	9.50		215TC	215TC	10.00		215TC	215TC	345	149	10.3			
4	7.60	7.50	213TC	213TC		215TC	215TC	275	119	8.2				
3	5.70	5.00	184TC	184TC		7.50	213TC	213TC	210	91	6.3			
2	3.80		184TC	184TC	5.00	184TC	184TC	140	61	4.2				
1	1.90		2.00	56C	56C	2.00	56C	56C	70	30	2.1			

22SV 3500 RPM

No. of Impellers	Maximum HP draw	Motor Selection using SF				Motor Selection 1.0 SF				Shutoff TDH (Feet)	Shutoff TDH (psi)	Shutoff TDH (Bar)	Casing/Sleeve Pressure Rating (standard assy.)	Pump Flange Rating
		Rated HP	NEMA Motor Frame		Rated HP	NEMA Motor Frame								
			ODP	TEFC		ODP	TEFC							
12	28.92	25.00	254TC	284TC	30.00	284TC	286TC	880	381	26.3	40 Bar (580 psi)	Class 250 / 300		
11	26.51		254TC	284TC		284TC	286TC	810	351	24.2				
10	24.10		254TC	284TC		25.00	254TC	284TC	735	318			21.9	
9	21.69	20.00	254TC	256TC	254TC		284TC	660	286	19.7				
8	19.28		254TC	256TC	20.00		254TC	256TC	585	253			17.5	
7	16.87		215TC	254TC		254TC	256TC	515	223	15.4				
6	14.46	15.00	215TC	254TC		15.00	215TC	254TC	440	191	13.1			
5	12.05		215TC	254TC	215TC		254TC	365	158	10.9				
4	9.64		10.00	215TC	215TC		10.00	215TC	215TC	295	128		8.8	
3	7.23	7.50	213TC	213TC	7.50	213TC	213TC	220	95	6.6				
2	4.82	5.00	184TC	184TC	5.00	184TC	184TC	245	106	7.3				
1	2.41	3.00	56C	56C	3.00	56C	56C	70	30	2.1				

TECHNICAL DATA - PUMP HYDRAULICS / MOTOR SIZING

33SV 3500 RPM

# of Impellers / # reduced Diameter	Maximum HP Draw	Motor HP for use with 1.15 SF Motor	Motor HP for use with Hydrovar (1.0 SF)	Shutoff TDH (Feet)	Shutoff TDH (Bar)	Casing / Sleeve Pressure rating (Standard Assy.)	Stages requiring Thrust Balancing Piston	Pump Flange Rating	
10	54.3	50	60	1125	34	40 Bar (580 PSI)	Thrust Piston Required	Class 250 / 300	
10/2	52.8			1096	33				
10/1	51.3			1066	32				
9	48.8		50	50	1012				30
9/1	47.4				983				29
9/2	45.9				954				28
8	43.4	40		50	900				27
8/1	41.9				871				26
8/2	40.5				842				25
7	38		40	40	787				23
7/1	36.5				758				23
7/2	35				729				22
6	32.6	30		40	576	20			
6/1	31.1				646	19			
6/2	29.6				617	18			
5	27.1		30	30	562	17			
5/1	25.7				533	16			
5/2	24.2				504	15			
4	21.7	25		25	450	13			
4/1	20.2				20	20	421	13	
4/2	18.8						392	12	
3	16.3		15	20			337	10	
3/1	14.7					15	15	310	9
3/2	13.2							281	8
2	10.9	10		15				225	7
2/1	9.4				10		10	196	6
2/2	7.9							167	5
1	5.4		7.5	7.5				113	3
1/1	4					5	5	84	3

① Pump assembly may be modified for 40 bar (580 psi) application - contact factory.

TECHNICAL DATA - PUMP HYDRAULICS / MOTOR SIZING

46SV 3500 RPM

# of Impellers / # reduced Diameter	Maximum HP Draw	Motor HP for use with 1.15 SF Motor	Motor HP for use with Hydrovar (1.0 SF)	Shutoff TDH (Feet)	Shutoff TDH (Bar)	Casing / Sleeve Pressure rating (Standard Assy.)	Stages requiring Thrust Balancing Piston	Pump Flange Rating			
10/2	77.8	75	75	1210	36.1	40 Bar (580 PSI)	Thrust Piston Required	Class 250 / 300			
9	73.2			1137	33.9						
9/1	71.5			1111	33.2						
9/2	69.7			1085	32.4						
8	65	60	75	1010	30.2						
8/1	63.3			984	29.4						
8/2	61.6			959	28.6						
7	56.9			884	26.4						
7/1	55.2	50	60	858	25.6				25 Bar (362 PSI) ①		Class 125 / 150
7/2	53.4			832	24.8						
6	48.8			758	22.6						
6/1	47.1			732	21.9						
6/2	45.3	40	40	706	21.1						
5	40.7			632	18.9						
5/1	38.9			605	18.1						
5/2	37.2			580	17.3						
4	32.5	30	30	505	15.1						
4/1	30.8			479	14.3						
4/2	29			453	13.5						
3	24.4			379	11.3						
3/1	22.7	20	25	353	10.5						
3/2	20.9			327	9.8						
2	16.3	15	20	253	7.6						
2/1	14.5			226	6.7						
2/2	12.8			200	6.0						
1	8.5			10	10	127	3.8				
1/1	6.7	7.5	7.5	102	3.0						

66SV 3500 RPM

# of Impellers / # reduced Diameter	Maximum HP Draw	Motor HP for use with 1.15 SF Motor	Motor HP for use with Hydrovar (1.0 SF)	Shutoff TDH (Feet)	Shutoff TDH (Bar)	Casing / Sleeve Pressure rating (Standard Assy.)	Stages requiring Thrust Balancing Piston	Pump Flange Rating			
6	73.2	75	75	850	25.4	40 Bar (580 PSI)	Thrust Piston Required	Class 250 / 300			
6/1	70.2			822	24.5						
6/2	67.2			796	23.8						
5	61	60	60	707	21.1				25 Bar (362 PSI) ①		Class 125 / 150
5/1	58			681	20.3						
5/2	55			655	19.6						
4	48.8	50	50	566	16.9						
4/1	45.8			540	16.1						
4/2	42.8			513	15.3						
3	36.6	40	40	424	12.7						
3/1	33.6			398	11.9						
3/2	30.6			372	11.1						
2	24.4	25	25	283	8.4						
2/1	21.4			257	7.7						
2/2	18.4			230	6.9						
1	12.2	15	15	142	4.2						
1/1	9.2			10	10	115	3.4				

① Pump assembly may be modified for 40 bar (580 psi) application - contact factory.

TECHNICAL DATA - PUMP HYDRAULICS / MOTOR SIZING

92SV 3500 RPM

# of Impellers / # reduced Diameter	Maximum HP Draw	Motor HP for use with 1.15 SF Motor	Motor HP for use with Hydrovar (1.0 SF)	Shutoff TDH (Feet)	Shutoff TDH (Bar)	Casing / Sleeve Pressure rating (Standard Assy.)	Stages requiring Thrust Balancing Piston	Pump Flange Rating
5/1	73.8	75	75	732	21.9	25 Bar (362 PSI) ①	Thrust Piston Required	Class 250 / 300
5/2	70.3			707	21.1			
4	61.9	60	60	605	18.1			
4/1	58.3			580	17.3			
4/2	54.8			556	16.6			
3	46.5	50	50	454	13.6			
3/1	42.9	40	40	429	12.8			
3/2	39.4			405	12.1			
2	31	30	30	305	9.1			
2/1	27.4			278	8.3			
2/2	23.4	25	25	253	7.6			
1	15.5	15	15	151	4.5			
1/1	12			127	3.8			

① Pump assembly may be modified for 40 bar (580 psi) application - contact factory.

125SV 3500 RPM

No. of Impellers	Maximum HP draw	Motor Selection using SF			Motor Selection 1.0 SF			Shutoff TDH (Feet)	Shutoff TDH (psi)	Shutoff TDH (Bar)	Casing/Sleeve Pressure Rating (standard assy.)	Pump Flange Rating
		Rated HP	NEMA Motor Frame		Rated HP	NEMA Motor Frame						
			ODP	TEFC		ODP	TEFC					
5/0C	82.32	75	364TSC	365TSC	Contact Factory			643	278	19.2	25 Bar (362 psi)	Class 250 / 300
5/5B	67.84	60	324TSC	326TSC	75	364TSC	365TSC	555	240	16.6		
4/3B	57.35	50	324TSC	326TSC	60	324TSC	326TSC	461	200	13.8		
3/3A	45.60	40	286TC	286TC	50	324TSC	326TSC	358	155	10.7		
2/0C	34.79	30	284TC	286TC	40	286TC	286TC	263	114	7.8		
1/0C	17.40	15	215TC	254TC	20	254TC	256TC	131	57	3.9		Class 125 / 150

TECHNICAL DATA - PUMP HYDRAULICS / MOTOR SIZING

1SV 1750 RPM

No. of Impellers	Maximum HP draw	Motor Selection using SF		Motor Selection 1.0 SF		Shutoff TDH (Feet)	Shutoff TDH (psi)	Shutoff TDH (Bar)	Casing/Sleeve Pressure Rating (standard assy.)	Pump Flange Rating		
		Rated HP	NEMA Motor Frame		Rated HP						NEMA Motor Frame	
			ODP	TEFC							ODP	TEFC
30	0.44	0.50	56C	56C	0.50	56C	56C	210	91	6.3	25 Bar (362 psi)	Class 250 / 300
29	0.43		56C	56C		56C	56C	203	88	6.1		
28	0.41		56C	56C		56C	56C	196	85	5.8		
27	0.40		56C	56C		56C	56C	189	82	5.6		
26	0.38		56C	56C		56C	56C	181	78	5.4		
25	0.37		56C	56C		56C	56C	175	76	5.2		
24	0.36		56C	56C		56C	56C	168	73	5.0		
23	0.34		56C	56C		56C	56C	162	70	4.8		
22	0.33		56C	56C		56C	56C	155	67	4.6		
21	0.31		56C	56C		56C	56C	148	64	4.4		
20	0.30		56C	56C		56C	56C	141	61	4.2		
19	0.28		56C	56C		56C	56C	134	58	4.0		
18	0.27		56C	56C		56C	56C	127	55	3.8		
17	0.25		56C	56C		56C	56C	120	52	3.6		
15	0.22		56C	56C		56C	56C	107	46	3.2		
14	0.21		56C	56C		56C	56C	100	43	3.0		
13	0.19		56C	56C		56C	56C	93	40	2.8		
12	0.18		56C	56C		56C	56C	86	37	2.6		
11	0.16		56C	56C		56C	56C	79	34	2.4		
10	0.15		56C	56C		56C	56C	72	31	2.1		
9	0.13		56C	56C		56C	56C	65	28	1.9		
8	0.12		56C	56C		56C	56C	58	25	1.7		
7	0.10		56C	56C		56C	56C	50	22	1.5		
6	0.09		56C	56C		56C	56C	43	19	1.3		
5	0.07		56C	56C		56C	56C	36	16	1.1		
4	0.06		56C	56C		56C	56C	29	13	0.9		
3	0.04		56C	56C		56C	56C	22	10	0.7		
2	0.03		56C	56C		56C	56C	15	6	0.4		

3SV 1750 RPM

No. of Impellers	Maximum HP draw	Motor Selection using SF		Motor Selection 1.0 SF		Shutoff TDH (Feet)	Shutoff TDH (psi)	Shutoff TDH (Bar)	Casing/Sleeve Pressure Rating (standard assy.)	Pump Flange Rating		
		Rated HP	NEMA Motor Frame		Rated HP						NEMA Motor Frame	
			ODP	TEFC							ODP	TEFC
30	0.73	0.75	56C	56C	0.75	56C	56C	267	116	8.0	25 Bar (362 psi)	Class 250 / 300
29	0.71		56C	56C		56C	56C	257	111	7.7		
28	0.68		56C	56C		56C	56C	249	108	7.4		
27	0.66		56C	56C		56C	56C	240	104	7.2		
26	0.63		56C	56C		56C	56C	231	100	6.9		
25	0.61		56C	56C		56C	56C	222	96	6.6		
24	0.59		56C	56C		56C	56C	213	92	6.4		
23	0.56		56C	56C		56C	56C	204	88	6.1		
22	0.54		56C	56C		56C	56C	194	84	5.8		
21	0.51		56C	56C		56C	56C	184	80	5.5		
20	0.49		56C	56C		56C	56C	167	72	5.0		
19	0.46		56C	56C		56C	56C	162	70	4.8		
18	0.44		56C	56C		56C	56C	156	68	4.7		
17	0.41		56C	56C		56C	56C	150	65	4.5		
16	0.39	56C	56C	56C	56C	141	61	4.2				
15	0.37	56C	56C	56C	56C	132	57	3.9				
14	0.34	56C	56C	56C	56C	124	54	3.7				
13	0.32	56C	56C	56C	56C	115	50	3.4				
12	0.29	56C	56C	56C	56C	105	45	3.1				
11	0.27	56C	56C	0.50	56C	56C	97	42	2.9			
10	0.24	56C	56C		56C	56C	89	39	2.7			
9	0.22	56C	56C		56C	56C	80	35	2.4			
8	0.20	56C	56C		56C	56C	71	31	2.1			
7	0.17	56C	56C		56C	56C	63	27	1.9			
6	0.15	56C	56C		56C	56C	54	23	1.6			
5	0.12	56C	56C		56C	56C	45	19	1.3			
4	0.10	56C	56C		56C	56C	36	16	1.1			
3	0.07	56C	56C		56C	56C	28	12	0.8			
2	0.05	56C	56C		56C	56C	19	8	0.6			

TECHNICAL DATA - PUMP HYDRAULICS / MOTOR SIZING

5SV 1750 RPM

No. of Impellers	Maximum HP draw	Motor Selection using SF				Motor Selection 1.0 SF				Shutoff TDH (Feet)	Shutoff TDH (psi)	Shutoff TDH (Bar)	Casing/Sleeve Pressure Rating (standard assy.)	Pump Flange Rating
		Rated HP	NEMA Motor Frame		Rated HP	NEMA Motor Frame								
			ODP	TEFC		ODP	TEFC							
27	1.02	1.00	56C	56C	1.50	56C	56C	239	104	7.1	25 Bar (362 psi)	Class 250 / 300		
26	0.98		56C	56C		56C	56C	230	100	6.9				
25	0.94		56C	56C		1.00	56C	56C	220	95			6.6	
24	0.90		56C	56C			56C	56C	212	92			6.3	
23	0.87	56C	56C	56C	56C		203	88	6.1					
22	0.83	56C	56C	56C	56C		195	84	5.8					
21	0.79	.75	56C	56C	0.75	56C	56C	186	81	5.6				
20	0.75		56C	56C		56C	56C	177	77	5.3				
19	0.72		56C	56C		56C	56C	167	72	5.0				
18	0.68		56C	56C		56C	56C	159	69	4.7				
17	0.64	0.50	56C	56C	0.50	56C	56C	150	65	4.5				
16	0.60		56C	56C		56C	56C	142	61	4.2				
15	0.57		56C	56C		56C	56C	133	58	4.0				
14	0.53		56C	56C		56C	56C	124	54	3.7				
13	0.49	0.50	56C	56C	0.50	56C	56C	114	49	3.4				
12	0.45		56C	56C		56C	56C	106	46	3.2				
11	0.41		56C	56C		56C	56C	97	42	2.9				
10	0.38		56C	56C		56C	56C	88	38	2.6				
9	0.34	0.50	56C	56C	0.50	56C	56C	79	34	2.4				
8	0.30		56C	56C		56C	56C	71	31	2.1				
7	0.26		56C	56C		56C	56C	62	27	1.9				
6	0.23		56C	56C		56C	56C	54	23	1.6				
5	0.19	0.50	56C	56C	0.50	56C	56C	45	19	1.3				
4	0.15		56C	56C		56C	56C	37	16	1.1				
3	0.11		56C	56C		56C	56C	28	12	0.8				
2	0.08		56C	56C		56C	56C	19	8	0.6				

10SV 1750 RPM

No. of Impellers	Maximum HP draw	Motor Selection using SF				Motor Selection 1.0 SF				Shutoff TDH (Feet)	Shutoff TDH (psi)	Shutoff TDH (Bar)	Casing/Sleeve Pressure Rating (standard assy.)	Pump Flange Rating
		Rated HP	NEMA Motor Frame		Rated HP	NEMA Motor Frame								
			ODP	TEFC		ODP	TEFC							
20	2.34	3.00	56C	56C	3.00	56C	56C	286	124	8.5	25 Bar (362 psi)	Class 250 / 300		
19	2.22	2.00	56C	56C		56C	56C	272	118	8.1				
18	2.11		56C	56C		2.00	56C	56C	257	111			7.7	
17	1.99		56C	56C	56C		56C	243	105	7.3				
16	1.87		56C	56C	56C		56C	229	99	6.8				
15	1.76	56C	56C	1.50	56C		56C	214	93	6.4				
14	1.64	56C	56C		56C	56C	200	87	6.0					
13	1.52	56C	56C		56C	56C	185	80	5.5					
12	1.40	56C	56C		1.50	56C	56C	170	74	5.1				
11	1.29	56C	56C	56C		56C	154	67	4.6					
10	1.17	1.00	56C	56C		56C	56C	141	61	4.2				
9	1.05		56C	56C		56C	56C	127	55	3.8				
8	0.94		0.75	56C	56C	1.00	56C	56C	113	49			3.4	
7	0.82			56C	56C		56C	56C	98	42			2.9	
6	0.70	56C		56C	0.75		56C	56C	85	37			2.5	
5	0.59	56C		56C			56C	56C	71	31			2.1	
4	0.47	0.50	56C	56C		0.50	56C	56C	57	25			1.7	
3	0.35		56C	56C			56C	56C	43	19			1.3	
2	0.23		56C	56C	56C		56C	29	13	0.9				
1	0.12		56C	56C	56C		56C	14	6	0.4				

TECHNICAL DATA - PUMP HYDRAULICS / MOTOR SIZING

15SV 1750 RPM

No. of Impellers	Maximum HP draw	Motor Selection using SF				Motor Selection 1.0 SF				Shutoff TDH (Feet)	Shutoff TDH (psi)	Shutoff TDH (Bar)	Casing/Sleeve Pressure Rating (standard assy.)	Pump Flange Rating			
		Rated HP	NEMA Motor Frame		Rated HP	NEMA Motor Frame											
			ODP	TEFC		ODP	TEFC										
15	3.56	5.00	184TC	184TC	5.00	184TC	184TC	263	114	7.8	25 Bar (362 psi)	Class 250 / 300					
14	3.32		3.00	56C		56C	3.00	184TC	184TC	245			106	7.3			
13	3.08			56C		56C		3.00	184TC	184TC			228	99	6.8		
12	2.84	56C		56C	3.00	56C			56C	210			91	6.3			
11	2.61	56C		56C		3.00			56C	56C			192	83	5.7		
10	2.37	56C		56C					3.00	56C			56C	175	76	5.2	
9	2.13	56C		56C						3.00			56C	56C	158	68	4.7
8	1.90	2.00	56C	56C			2.00						56C	56C	140	61	4.2
7	1.66		1.50	56C				56C					1.50	56C	56C	120	52
6	1.42			56C	56C			1.50						56C	56C	103	45
5	1.19	1.00		56C	56C	1.00	56C							56C	86	37	2.6
4	0.95		56C	56C	1.00		56C		56C				68	29	2.0		
3	0.71		56C	56C			0.75	56C	56C	51			22	1.5			
2	0.47	0.50	56C	56C		0.50		56C	56C	35			15	1.0			
1	0.24		56C	56C	0.50			56C	56C	8			3	0.2			

22SV 1750 RPM

No. of Impellers	Maximum HP draw	Motor Selection using SF				Motor Selection 1.0 SF				Shutoff TDH (Feet)	Shutoff TDH (psi)	Shutoff TDH (Bar)	Casing/Sleeve Pressure Rating (standard assy.)	Pump Flange Rating			
		Rated HP	NEMA Motor Frame		Rated HP	NEMA Motor Frame											
			ODP	TEFC		ODP	TEFC										
12	3.58	5.00	184TC	184TC	5.00	184TC	184TC	220	95	6.6	25 Bar (362 psi)	Class 250 / 300					
11	3.28		3.00	56C		56C	3.00	184TC	184TC	202			87	6.0			
10	2.98			56C		56C		3.00	56C	56C			183	79	5.5		
9	2.68	56C		56C	3.00	56C			56C	165			71	4.9			
8	2.38	56C		56C		3.00			56C	56C			147	64	4.4		
7	2.09	56C		56C					3.00	56C			56C	129	56	3.8	
6	1.79	2.00		56C						56C			2.00	56C	56C	110	48
5	1.49		1.50	56C			56C			1.50				56C	56C	91	39
4	1.19			56C			56C	1.50						56C	56C	74	32
3	0.89	0.75		56C	56C		1.00						56C	56C	55	24	1.6
2	0.60		0.50	56C	56C	0.75				56C			56C	36	16	1.1	
1	0.30			56C	56C			0.50	56C	56C			19	8	0.6		

TECHNICAL DATA - PUMP HYDRAULICS / MOTOR SIZING

33SV 1750 RPM

No. of Impellers	Maximum HP draw	Motor Selection using SF			Motor Selection 1.0 SF			Shutoff TDH (Feet)	Shutoff TDH (psi)	Shutoff TDH (Bar)	Casing/Sleeve Pressure Rating (standard assy.)	Pump Flange Rating	Stages Requiring Thrust Balancing Piston
		Rated HP	NEMA Motor Frame		Rated HP	NEMA Motor Frame							
			ODP	TEFC		ODP	TEFC						
10	7.0	7.5	184TC	7.5	184TC	278	120	8	25 Bar (362 psi)	Class 125 / 150			
10/1	6.8					271	117	8					
10/2	6.8					264	114	8					
9	6.3					250	108	7					
9/1	6.1					242	105	7					
9/2	6.1					235	102	7					
8	5.6					222	96	7					
8/1	5.4	214		93		6							
8/2	5.4	207		90		6							
7	4.9	5		184TC		5	184TC	195				84	6
7/1	4.7							189				82	6
7/2	4.7							181				78	5
6	4.2							168				73	5
6/1	4.0							160				69	5
6/2	3.9		153		66			5					
5	3.5		139		60			4					
5/1	3.3	131	57		4								
5/2	3.2	124	54		4								
4	2.8	3	184TC		3	184TC		111				48	3
4/1	2.6							103				45	3
4/2	2.5							97				42	3
3	2.1							83				36	2
3/1	2.0							76				33	2
3/2	1.8			70			30	2					
2	1.4			56			24	2					
2/1	1.2	48		21	1								
2/2	1.1	41		18	1								
1	0.7							28				12	1

TECHNICAL DATA - PUMP HYDRAULICS / MOTOR SIZING

46SV 1750 RPM

No. of Impellers	Maximum HP draw	Motor Selection using SF			Motor Selection 1.0 SF			Shutoff TDH (Feet)	Shutoff TDH (psi)	Shutoff TDH (Bar)	Casing/Sleeve Pressure Rating (standard assy.)	Pump Flange Rating	Stages Requiring Thrust Balancing Piston
		Rated HP	NEMA Motor Frame		Rated HP	NEMA Motor Frame							
			ODP	TEFC		ODP	TEFC						
10/2	10.0	10	215TC	215TC	10	213TC	215TC	298	129	9	25 Bar (362 psi)	Class 125 / 150	
9	9.3							280	121	8			
9/1	9.0							274	119	8			
9/2	8.8							268	116	8			
8	8.2	7.5	184TC	184TC	7.5	184TC	249	108	7				
8/1	8.0						242	105	7				
8/2	7.8						236	102	7				
7	7.2						217	94	6				
7/1	7.0						212	92	6				
7/2	6.8						206	89	6				
6	6.2	5	184TC	184TC	5	184TC	189	82	6				
6/1	6.0						182	79	5				
6/2	5.8						174	75	5				
5	5.2						156	68	5				
5/1	5.0						150	65	4				
5/2	4.7						144	62	4				
4	4.1	3	184TC	184TC	3	184TC	125	54	4				
4/1	3.8						118	51	4				
4/2	3.7						113	49	3				
3	3.1						93	40	3				
3/1	2.9						87	38	3				
3/2	2.6						79	34	2				
2	2.0	3	184TC	184TC	3	184TC	63	27	2				
2/1	1.8						55	24	2				
2/2	1.6						49	21	1				
1	1.0						31	13	1				

66SV 1750 RPM

No. of Impellers	Maximum HP draw	Motor Selection using SF			Motor Selection 1.0 SF			Shutoff TDH (Feet)	Shutoff TDH (psi)	Shutoff TDH (Bar)	Casing/Sleeve Pressure Rating (standard assy.)	Pump Flange Rating	Stages Requiring Thrust Balancing Piston
		Rated HP	NEMA Motor Frame		Rated HP	NEMA Motor Frame							
			ODP	TEFC		ODP	TEFC						
6	9.0	10	215TC	215TC	10	213TC	215TC	211	91	6	25 Bar (362 psi)	Class 125 / 150	
6/1	8.6							203	88	6			
6/2	8.3	7.5	184TC	184TC	7.5	184TC	197	85	6				
5	7.5						175	76	5				
5/1	7.1						168	73	5				
5/2	6.9						162	70	5				
4	6.0						140	61	4				
4/1	5.6						134	58	4				
4/2	5.4	127	55	4									
3	4.5	5	184TC	184TC	5	184TC	106	46	3				
3/1	4.1						98	42	3				
3/2	3.9						92	40	3				
2	3.0						70	30	2				
2/1	2.6	3	184TC	184TC	3	184TC	64	28	2				
2/2	2.4						57	25	2				
1	1.5						36	15	1				

TECHNICAL DATA - PUMP HYDRAULICS / MOTOR SIZING

92SV 1750 RPM

No. of Impellers	Maximum HP draw	Motor Selection using SF			Motor Selection 1.0 SF			Shutoff TDH (Feet)	Shutoff TDH (psi)	Shutoff TDH (Bar)	Casing/Sleeve Pressure Rating (standard assy.)	Pump Flange Rating	Stages Requiring Thrust Balancing Piston
		Rated HP	NEMA Motor Frame		Rated HP	NEMA Motor Frame							
			ODP	TEFC		ODP	TEFC						
6	11.5	10	215TC	215TC	15	215TC	254TC	227	98	7	25 Bar (362 psi)	Class 125 / 150	
6/1	11.1							221	96	7			
6/2	10.7							215	93	6			
5	9.8				10	213TC	215TC	190	82	6			
5/1	9.7							184	80	5			
5/2	9.2							178	77	5			
4	7.7	7.5	184TC	7.5	184TC	153	66	5					
4/1	7.6					146	63	4					
4/2	7.1					140	61	4					
3	5.8					114	49	3					
3/1	5.6					107	46	3					
3/2	5.1					102	44	3					
2	3.9	5	184TC	5	184TC	76	33	2					
2/1	3.6					69	30	2					
2/2	3.1	3	184TC	3	184TC	64	28	2					
1	1.9					37	16	1					
1/1	1.6					31	14	1					

125SV 1750 RPM

No. of Impellers	Maximum HP draw	Motor Selection using SF			Motor Selection 1.0 SF			Shutoff TDH (Feet)	Shutoff TDH (psi)	Shutoff TDH (Bar)	Casing/Sleeve Pressure Rating (standard assy.)	Pump Flange Rating
		Rated HP	NEMA Motor Frame		Rated HP	NEMA Motor Frame						
			ODP	TEFC		ODP	TEFC					
8/0C	16.47	15	215TC	254TC	20	254TC	256TC	257	111	7.7	25 Bar (362 psi)	Class 125 / 150
7/0C	14.22	15	215TC	254TC	15	215TC	254TC	225	97	6.7		
6/6A	11.4	10	213TC	215TC	15	215TC	254TC	179	78	5.3		
5/5A	9.5	10	213TC	215TC	10	213TC	215TC	150	65	4.5		
4/0C	8.23	7.5	184TC	184TC	10	213TC	215TC	128	55	3.8		
3/3A	5.70	5	182TC	184TC	7.5	184TC	184TC	89	39	2.7		
2/0C	4.36	5	182TC	184TC	5	182TC	184TC	66	29	2.0		

PACKAGED e-SV HYDROVAR SERIES VARIABLE SPEED WATER BOOSTER WITH e-SV VERTICAL MULTISTAGE PUMP AND FUSED DISCONNECT

PACKAGED HYDROVAR / e-SV COVERAGE CHART

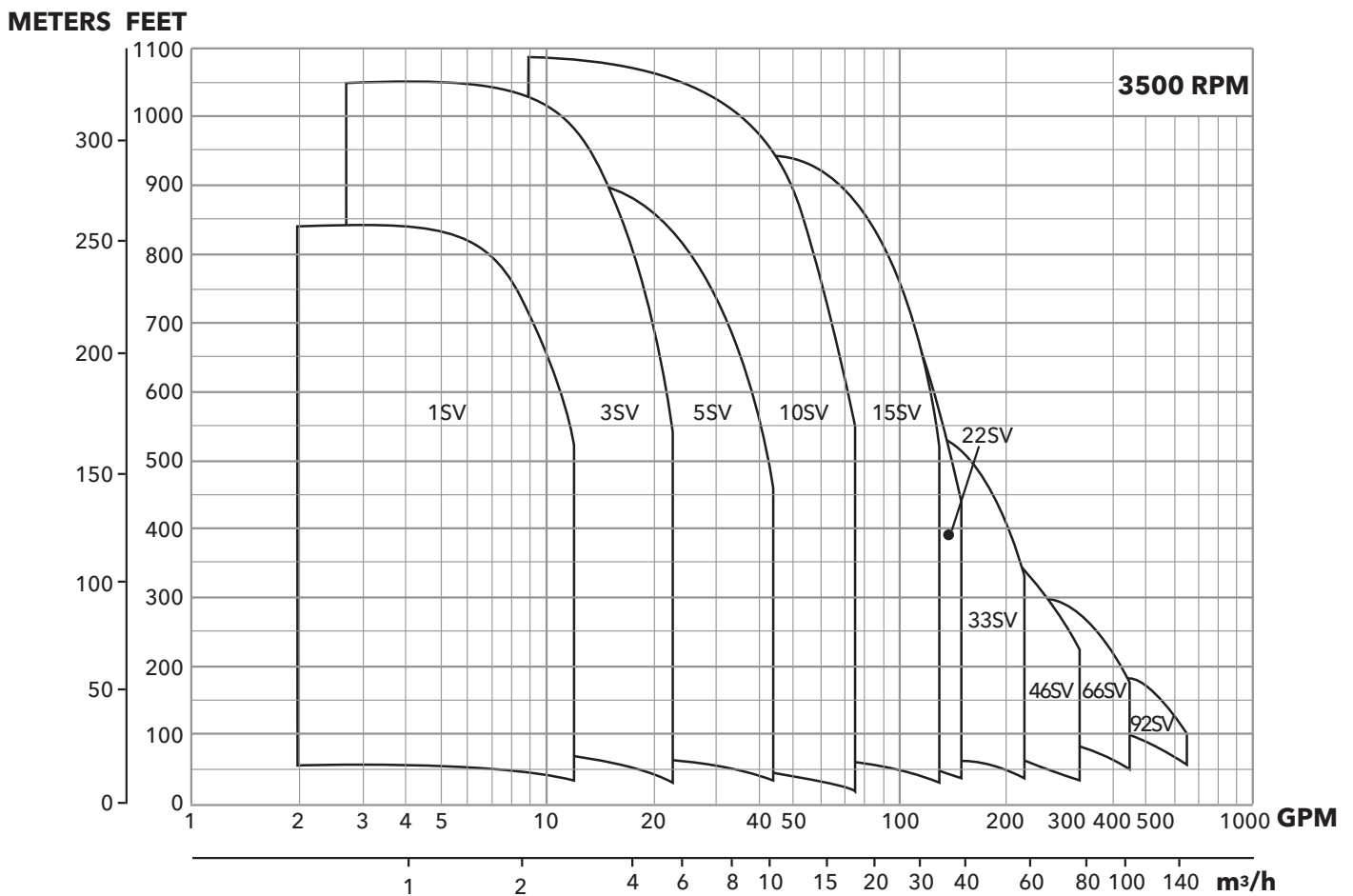

NOTE: Refer to e-SV Technical Brochure and/or the selection software for final e-SV pump selection.

Commercial Water

MAIN COMPONENTS

of constant pressure variable speed system

- One multistage vertical **pump**, Goulds Water Technology e-SV series.
 - **Hydrovar**® pump mounted variable speed drive, NEMA 1 enclosure
 - **Pressure transducer** for constant pressure control, connected to the Hydrovar drive.
 - **NEMA 4X** fused disconnect panel with corrosion resistant durable plastic; external on/off switch with lockout/tagout. Panel is bracket mounted directly to pump. Includes fast acting fuses.
 - UL Package listing
 - Factory tested and assembled. Pre-programmed, wired, and electrically tested.
- 1) Vertical multi-stage stainless pump
 - 2) TEFC NEMA 2-pole motor
 - 3) NEMA 4X fused disconnect panel
 - 4) Hydrovar® variable speed controller
 - 5) Pressure transducer (sensor) with cable



"Packaged Pumping System"



MARKETS AND APPLICATIONS

Booster Sets

MARKETS SERVED

MUNICIPAL, COMMERCIAL, INDUSTRIAL

APPLICATIONS

- Water network supply in condominiums, offices, hotels, shopping centers, factories, water treatment, process control.
- Water supply to agricultural water networks (e.g. irrigation).
- Variable flow / demand applications requiring constant pressure control.

SPECIFICATIONS

- **Flow rate** up to 725 GPM
- **Head** up to 1,080' TDH
- **Input Supply:**
 - 1Ø Input 208/230 volt 2 - 5 HP
 - 3Ø Input 208/230 volt 2 - 15 HP
 - 3Ø Input 460 volt 2 - 30 HP
- **Output voltage:**
 - 3Ø, 230V 2 - 15 HP
 - 3Ø, 460V 2 - 30 HP
 - (208 - 240V ± 10%, 15 - 70 Hz)
 - (380 - 460V ± 10%, 15 - 70 Hz)
- Input Frequency: 50 or 60 Hz
- External control voltage:
 - 0-5 VDC; 0-10 VDC; 0-20 mA
- Protection class
 - panel: NEMA 4X
 - drive: NEMA1 up to 30 HP
- Maximum HP: 30 HP
- Soft motor start
- **Vertical design pump:**
 - e-SV series (motor insulation class, F, TEFC enclosure)
- Maximum operating pressure: 500 PSI
- Maximum temperature of pumped liquid: 250° F



Commercial Water

MARKETS AND APPLICATIONS *(continued)*

WATER SUPPLY AND PRESSURE BOOSTING

- Pressure boosting in buildings, hotels, residential complexes
- Pressure booster stations, supply of water networks
- Booster packages

WATER TREATMENT

- Ultrafiltration systems
- Reverse osmosis systems
- Water softeners and de-mineralization
- Distillation systems
- Filtration

LIGHT INDUSTRY

- Washing and cleaning plants (washing and degreasing of mechanical parts, car and truck wash tunnels, washing of electronic industry circuits)
- Commercial washers
- Firefighting system pumps

IRRIGATION AND AGRICULTURE

- Greenhouses
- Humidifiers
- Sprinkler irrigation

HEATING, VENTILATION AND AIR CONDITIONING (HVAC)

- Cooling towers and systems
- Temperature control systems
- Refrigerators
- Induction heating
- Heat exchangers
- Boilers
- Water recirculation and heating

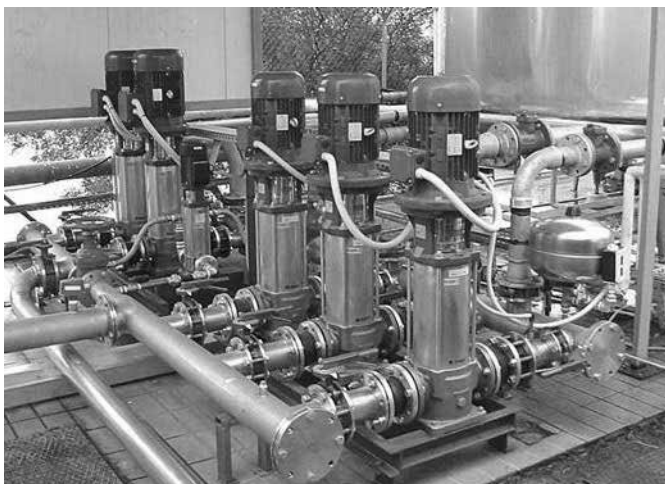
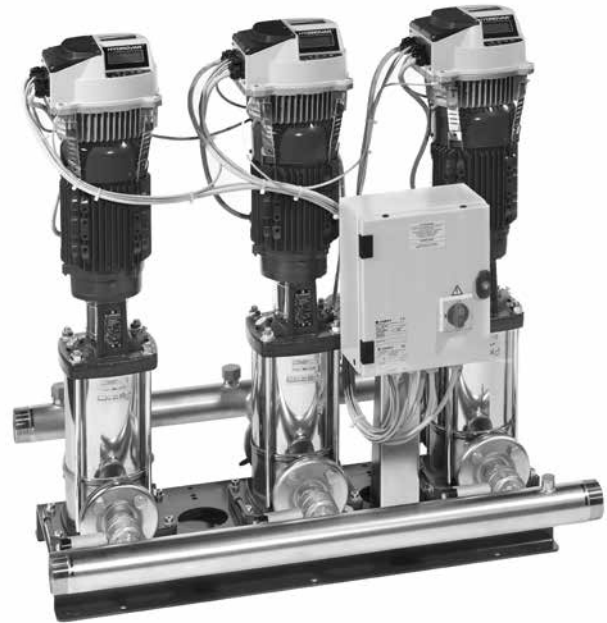

MARKETS AND APPLICATIONS *(continued)*

MUNICIPAL, AGRICULTURAL, LIGHT INDUSTRY, WATER TREATMENT, HEATING AND AIR CONDITIONING

APPLICATIONS

- Handling of water, free of suspended solids, in the municipal, industrial and agricultural markets
- Pressure boosting and water supply systems
- Fire fighting jockey pumps
- Irrigation systems
- Wash systems
- Water treatment plants: reverse osmosis
- Handling of moderately aggressive liquids, demineralized water, water and glycol, etc.
- Circulation of hot and cold water for heating, cooling and conditioning systems
- Boiler feed

SPECIFICATIONS

PUMP

The e-SV pump is a non-self priming vertical multistage pump coupled to a standard motor.

The liquid end, located between the upper cover and the pump casing, is held in place by tie rods.

The pump casing is available with different configurations and connection types.

- Delivery: up to 600 GPM
- Head: up to 1200 feet
- Temperature of pumped liquid: -20°F to 250°F (-30°C to 120°C) standard version
- Maximum operating pressure
 - with oval flanges: 230 PSI (15 bar)
 - with round flanges or Victaulic: 360 PSI (25 bar)
 - SV33, 46: 230, 360 or 575 PSI (16, 25 or 40 bar)*
 - SV 66, 92: 230 or 360 PSI (16 or 25 bar)*
- Direction of rotation: clockwise looking at the pump from the top down (marked with an arrow on the adapter and on the coupling).

APPLICATION EXAMPLE - MULTI-PUMP "CASCADE"

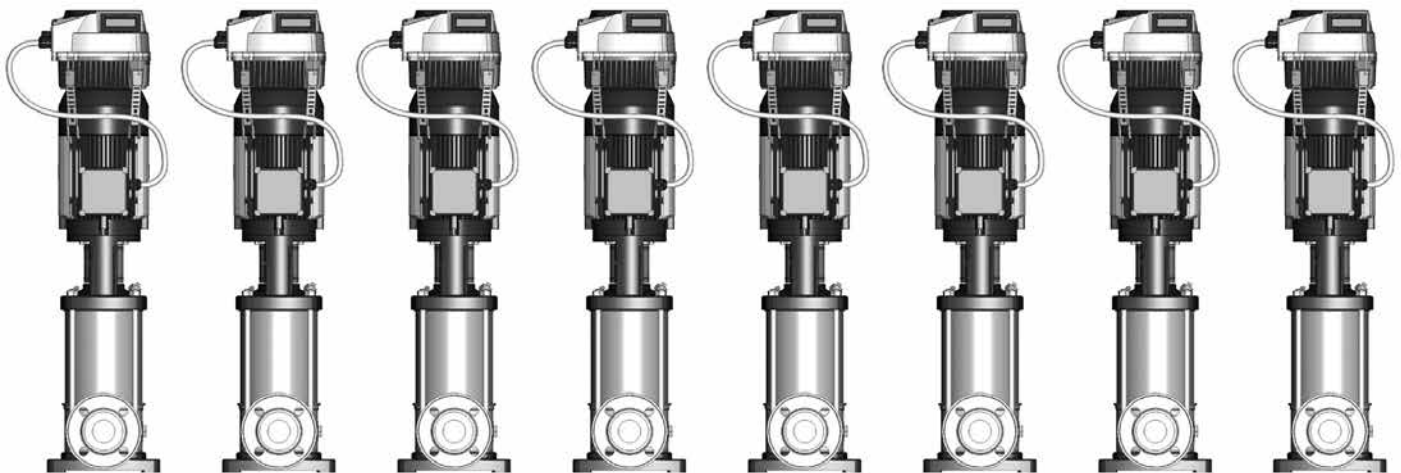

With the "master" version of the Hydrovar, it is possible to connect up to 8 Hydrovar controller pumps together in parallel. Complete lead/lag and auto alternation.

CHARACTERISTICS OF THE e-SV SERIES PUMP USED IN BOOSTER PACKAGE

1SV - 22SV e-SV VERTICAL MULTI-STAGE PUMPS

- High hydraulic efficiency for significant energy savings.
- Multistage centrifugal vertical electric pumps. All metal parts in contact with pumped liquid are made of 304/316 stainless steel.
- A version: round flanges, in-line discharge and suction ports, AISI 304
- B version: ANSI flanges, in-line discharge and suction ports, AISI 316
- Reduced axial thrusts enable the use of **standard motors** that are easily found on the market.
- Standard Baldor, NEMA motors
- Easy maintenance. No special tools required for assembly or disassembly.
- **ANSI/NSF 61 certified by CSA for potable drinking water.**

33SV - 125SV e-SV MULTI-STAGE PUMPS

- Vertical multistage centrifugal pump with impellers, diffusers and outer sleeve made entirely of stainless steel, and with pump casing and upper head made of cast iron in the standard version.
- High hydraulic efficiency for significant energy savings.
- Innovative axial load compensation system on pumps with higher head. This ensures reduced axial thrusts and enables the use of standard motors that are easily found on the market.
- Standard NEMA Baldor® motors.
- Mechanical seal can easily be replaced without disassembling the motor from the pump.
- Mechanical sturdiness and easy maintenance. No special tools required for assembly or disassembly.
- **ANSI/NSF 61 certified by CSA for potable drinking water.**

REFERENCE STANDARDS

- UL QCZJ Package listing
- VFD (Hydrovar) UL recognized
- Baldor motor UL recognized
- Pumps meet ANSI/NSF 61 certification by CSA for potable drinking water
- Control/disconnect meet UL508A standards

Commercial Water

MAIN CHARACTERISTICS OF FREQUENCY CONVERTERS USED IN THE PACKAGED BOOSTER SETS

The booster uses a **Hydrovar®** variable frequency drive, an automatic device that adjusts the speed of the electric pump in order to maintain **constant pressure** in the system.

Converters with power up to 30 HP are **mounted directly on to the motor**. The pressure is measured by a **pressure transmitter** which uses a standard **4..20 mA** current signal. The system pressure value can be read on the converter's display. A simple user interface allows you to set the desired pressure value for optimal adjustment, as well as to **view the operating data**, such as the hours of operation and any alarms triggered. Included diagnostic menu to view temperature, current and voltage values facilitates diagnostics and failure analysis. Indicator lights signal power status, pump running and malfunctions.



Modular Hydrovar, Bare Unit

A **password** is required to access sensitive settings that allow you to **program the Hydrovar** in order to adapt it to any control requirements, such as **flow resistance compensation, external control**, periodic testing and so on. When more than one pump is used, the converters exchange information with each other through an **RS485 serial line** which can connect up to 8 Hydrovar devices plus one external unit for remote control. The Pump-link and Pump-watcher dedicated systems, connected to the Hydrovar®, enable remote control through a traditional telephone line or mobile telephony. A serial port available as standard up to 15 HP allows you to control the Hydrovar® converters from a Modbus® field serial bus line.

The converter is equipped with two **potential-free relays** which can be used for **remote signalling** of pump running and malfunction status, plus a programmable voltage **analog output** for signalling the frequency or pressure. Standard version with two sensor inputs for implementing of two actual values signals within one system (min/max, difference) or for a second sensor for safety reasons. Specific digital **inputs** are used for protection against **water failure, motor overtemperature**, as well as for external enable signal and remote control. The converter also incorporates a dry running protection function via an adjustable **minimum pressure** threshold.

E.g. Industrial areas, technical areas of any building fed from a dedicated transformer are examples of environment locations.

FCC Class B filter standard for Hydrovar single-phase power supply.

Further information is available in the Hydrovar manual.



Packaged Hydrovar with e-SV Pump

HYDROVAR SPECIFICATIONS

Model	Hydrovar VFD					TEFC Motor		
	Input		HP	NEMA Class	Max Input Current (A)	Max Output Current (A)	Power Supply (Voltage/Phase)	HP
	Voltage (V)	Phase						
10073L1AAUST	208-240	1	2	1	11.6	7.5	230/3	2
10073L2AAUST			3		15.1	10		3
10073L4AAUST			5		27.6	16.7		5
10073L5AAUST	208-240	1	2		7	7.5		2
10073L6AAUST			3		9.1	10		3
10073L8AAUST			5		16.5	16.7		5
10073L9AAUST			7.5		23.5	24.2		7.5
10073LAAUST			10		29.6	31		10
10073LBAAUST			15		43.9	44		15
10073LCAUST	380-460	3	2		3.9	4.1	460/3	2
10073LDAAUST			3		5.3	5.7		3
10073LFAAUST			5		10.1	10		5
10073LGAAUST			7.5		12.8	13.5		7.5
10073LHAAUST			10		16.9	17		10
10073LLAAUST			15		24.2	24		15
10073LMAAUST			20		33.3	32		20
10073LNAAUST			25		38.1	38		25
10073LPAAUST			30		44.7	44		30

ELECTRICAL PANELS (Packaged Hydrovar® Series)

The Package comes with a **fused disconnect** on which are installed automatic **line protection fast acting fuses** for each drive. Class J or Class CC, 600 volt.

Single-pump Packages are supplied as standard with an electrical panel encased in NEMA 4X enclosure, with 2-pole or 3-pole (3 phase) up to 30 amps and featuring a **main switch**.

The fused disconnect is rated for UL508A.



Commercial Water

FUSED DISCONNECT BOX

Single Phase

CUSTOMER SUPPLIED VOLTAGE

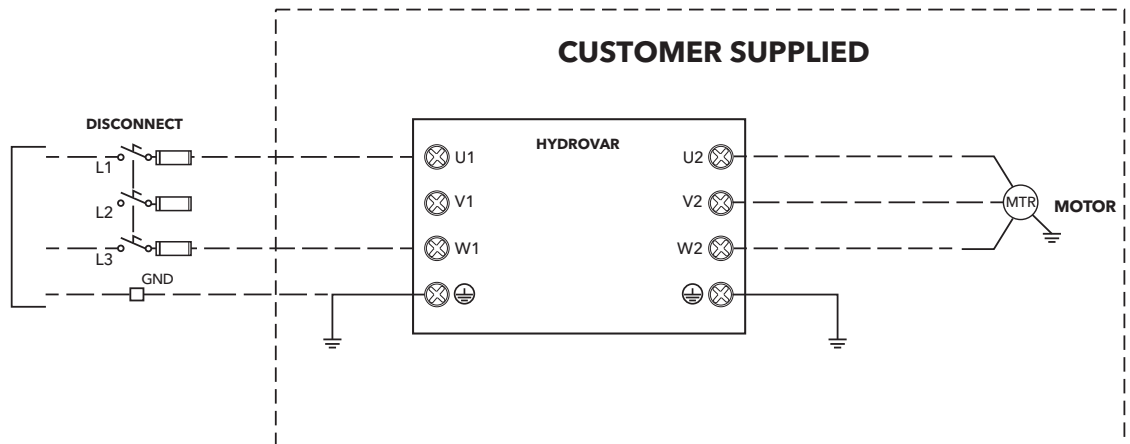

Three Phase

CUSTOMER SUPPLIED VOLTAGE

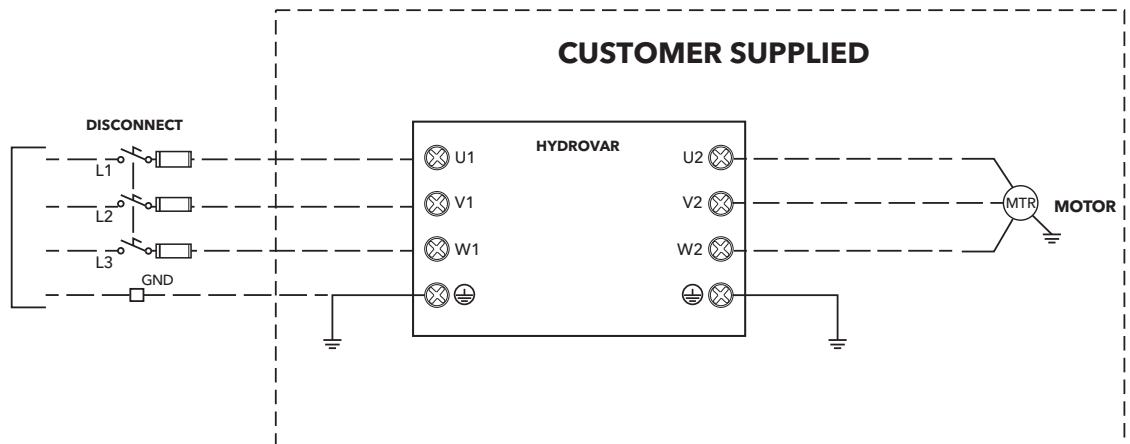

Disconnect Part Number	Input Voltage	NEMA Rating HP/ Amps	Wire AWG Disconnect to VFD	Tightening Torque	Fuse Brand	Amp Rating	Fuse Part Number	Max Voltage
HFD512C1-2	230V/1PH	2HP/12A	14	18 lbf-in	Bussmann	20	KTK-R-20	600V
HFD512E1-2	230V/1PH	3HP/17A	14	18 lbf-in	Bussmann	30	KTK-R-30	600V
HFD512F3-1	230V/1PH	5HP/28A	10	35.4 lbf-in	Bussmann	40	JJN-50	600V
HFD532C1-1	230V/3PH	2HP/6.8A	14	18 lbf-in	Bussmann	15	KTK-R-15	600V
HFD532E1-1	230V/3PH	3HP/9.6A	14	18 lbf-in	Bussmann	15	KTK-R-15	600V
HFD532C2-1	230V/3PH	5HP/15.2A	12	18 lbf-in	Bussmann	30	KTK-R-30	600V
HFD532E2-1	230V/3PH	7.5HP/22A	10	35.4 lbf-in	Bussmann	40	JJN-40	600V
HFD532F2-1	230V/3PH	10HP/28A	8	35.4 lbf-in	Bussmann	50	JJN-50	600V
HFD532G3-1	230V/3PH	15HP/42A	6	35.4 lbf-in	Bussmann	60	JJN-60	600V
HFD534A1-2	460V/3PH	2HP/ 3.4A	14	18 lbf-in	Bussmann	10	KTK-R-10	600V
		3HP/4.8A						
HFD534B1-2	460V/3PH	5HP/7.6A	14	18 lbf-in	Bussmann	15	KTK-R-15	600V
HFD534C1-2	460V/3PH	7.5HP/11A	14	18 lbf-in	Bussmann	20	KTK-R-20	600V
HFD534C2-2	460V/3PH	10HP/14A	12	18 lbf-in	Bussmann	20	KTK-R-20	600V
HFD534E2-2	460V/3PH	15HP/21A	10	18 lbf-in	Bussmann	30	KTK-R-30	600V
HFD534E3-1	460V/3PH	20HP/27A	8	35.4 lbf-in	Bussmann	50	JJS-50	600V
HFD534G3-1	460V/3PH	25HP/34A	6	35.4 lbf-in	Bussmann	60	JJS-60	600V
		30HP/40A						

Note: Recommended protection (not included with drive only). This fused disconnect is available as part of the Packaged Hydrovar, see price book.

OPERATION DESCRIPTION

PACKAGED HYDROVAR WITH PRESSURE TRANSDUCER CONTROL

The starting and stopping of the pumps are determined based on the pressure values set on the controller.

Each frequency converter is connected to a pressure transducer.

The controllers exchange information with each other and provide for cyclic changeover.

The figure shows the operating mode of a two-pump booster set (Typical Field Set).

- On demand, water is drawn from the tank.
- When the pressure drops below the PS setting the first pump starts and the speed is adjusted to maintain a constant pressure as demand increases.
- If the water consumption increases and the pump reaches maximum speed, the second pump starts and the speed is adjusted to maintain constant pressure.
- When demand decreases, the speed is reduced until minimum speed is reached and one of the pumps are switched off.
- If consumption keeps decreasing the pump slows down, fills the tank and stops at the pressure setting.

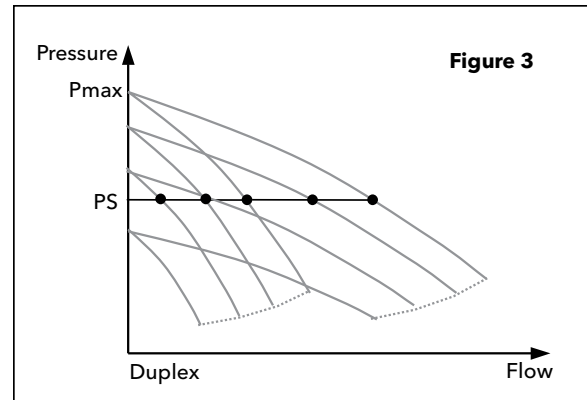

OPERATING CHARACTERISTICS AND LIMITS

Type of pumped liquids	Water containing no gas or corrosive and/or aggressive substances
Fluid temperature	Above 0° F to 180° F, pressure transducer limited
Ambient temperature	Above 0° F to 104° F, VFD/Display, keep away from direct sun
Maximum operating pressure	360 PSI (Pump without transducer)
Minimum inlet pressure	According to NPSH curve and losses, with a minimum margin of 0.5 m
Maximum inlet pressure	The inlet pressure added to the pressure of the pump at zero flow must be lower than the maximum operating pressure of the set (suction and discharge).
Installation	Indoors/outdoors, protected from the direct sun. Away from heat sources. Maximum elevation 3300 feet ASL. Maximum humidity 50% without condensation.
Hourly starts	Maximum 60 variable speed drive starts per hr up to 10 HP. Maximum 40 variable speed drive starts per hr above 10 HP.
Sound emission	See table

* **Note:** For higher temperature it is necessary to use special materials (only on request).

TYPICAL ACOUSTIC PERFORMANCE TEFC/SUPER-E MOTORS

NEMA Frame Size	PWL (dBA)	
	3600 RPM	1800 RPM
56		
180	70	67
210		
250	76	70
280	79	75

PERFORMANCE WITH VARYING SPEED FOR CENTRIFUGAL PUMPS

Fitting the electric pump with a variable speed drive makes it possible to vary the pump rotation speed, normally according to the system pressure parameter. **Variations in electric pump speed** result in **modified performances** according to the equivalence relations, called affinity laws.

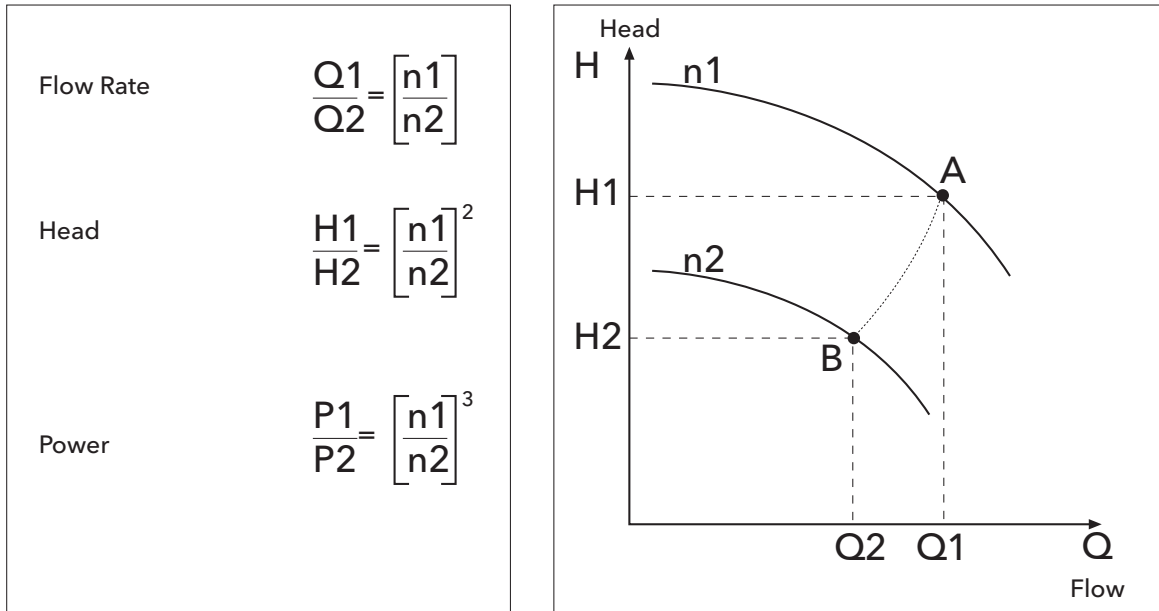

n1 = initial speed; n2= speed required.
 Q1 = initial flow rate; Q2= flow rate required.
 H1 = initial head; H2= head required.
 P1 = initial power; P2= power required

Frequency ratios can be used instead of speed in practical applications, keeping 30 Hz as the bottom limit.

Example : 2-pole 50 Hz electric pump n1 =2900 (point A)
 Flow rate (A) = 100 l/min; Head (A) = 50m
 By reducing the frequency to 30 Hz the speed is reduced to approx. n2 = 1740 rpm (point B)
 Flow rate (B) = 60 l/min; Head (B) = 18 m
 The power of the new work point B is cut to about 22% of the initial power.

SIZING THE DIAPHRAGM TANK IN SYSTEMS WITH SPEED VARIATION

Variable speed booster sets need **smaller tanks** compared to traditional systems. Generally speaking, a tank with a capacity of just 20% of the nominal capacity of a single pump, expressed in gallons per minute, is needed. The **gradual starting** of the pumps controlled by the drive reduces the need to limit the number of hourly starts; the main purpose of the tank is to compensate for small system losses, stabilize the pressure and make up for pressure variations caused by sudden demand (fast acting valves).

Make the following calculation:

Set made up of three electric pumps, each with a maximum flow rate of 100 GPM, for a total capacity of 300 GPM. The **volume** required for the tank is 20 gallons. This is total capacity, not drawdown. Mount downstream of the check valves in discharge manifold.

SELECTING A PACKAGE

The first thing to do when selecting a package is to determine the quantity of water required and the pressure it must supply.

Calculating the Flow Rate

The quantity of water called **water requirement** depends on the type of users, e.g. homes, offices, schools, as well as their number. The theoretic requirement is the total amount of water required by all the users. In actual fact, since it is very unlikely that there should be a simultaneous demand by all the users, the **real requirement** is lower than the theoretic one.

Calculating the Head

The pressure required depends on the type of user. A number of factors must be taken into account, including the **height of the building**, the suction conditions and the flow resistance in the pipes.

Selecting A Booster Set

According to the required flow rate and head values, it is possible to identify the most suitable size of e-SV pump. On two-pump sets the pumps normally act as **back-up for one another**. A single pump is normally sufficient to provide for average requirements, while in conditions of high demand the back up pump may be called in to assist. With the **cyclic changeover** function duty assignment is rotated to ensure both pumps remain active and with even running hours, so wear is uniform and the use factor is reduced for longer pump life. This system also ensures **continuity of operation** in case one of the pumps needs maintenance. The Hydrovar provides automatic lead/lag, alternation when programmed in multi-control and wired via RS485 communication terminals.

Tank

Frequent demand or **small system losses** determine pressure variations that may be compensated for by using a **tank**. Correct selection of a diaphragm tank **reduces the number of pump starts** and, if it is installed near the booster set, helps reduce the effect of water hammer, or fast acting flush valves.

The booster sets are **ready** for installation of diaphragm tanks directly on the delivery manifold, and additional tanks can be connected to the unused end of the manifold.

For peak performance, variable speed booster sets need **smaller tanks** compared to traditional systems.

Generally speaking, a tank with a capacity of just 20% of the nominal capacity of a single pump, expressed in gallons per minute, is required. Example: If my pump is sized for 100 GPM, then we would size a 20 gallon (total capacity) diaphragm tank.

Pre-charge the tank with air, 10-15 PSI below your system pressure. Charge dry tank without water pressure or before installing in system.

PART NUMBERING / IDENTIFICATION CODES

PACKAGED HYDROVAR VARIABLE SPEED e-SV PRODUCT LINE NUMBERING SYSTEM

The various versions are identified by a product code number on the pump label. The number is also the catalog number for the package. The meaning of each digit in the product code is shown below.

Packaged Hydrovar/e-SV Example Product Code

10 SV 7 F H 4 F 2 0 V32

Hydrovar Input Power (Phase)

V12 = Single Phase, 230V V32 = Three Phase, 230V

V34 = Three Phase, 460V

1SV - 125SV Selections Available

See e-SV Technical Manual and Price Sheets for pump / motor / options code selections.

Note: 300 PSI transducer is supplied as standard. All e-SV motors will be TEFC 3-phase construction. Optional 500 psi transducer is available.

CAUTION: Pump, flanges and other piping system components must also be rated for the maximum system pressure. See e-SV technical manual and other appropriate technical manuals to verify all equipment is rated to maximum system pressure.

Building the order number for the Packaged e-SV Hydrovar System

1) The e-SV pump order number is built and priced using the e-SV Technical manual, selection software, and/or the price book.

Note: The Order Number System is shown on page 5 in this book.

All Packaged e-SV Hydrovars systems use three phase TEFC motors.

2) The Pump and motor option requirements are added to the order number from the same e-SV literature.

3) Add option suffix V12, V32 or V34 to the pump order number to complet the packge.

Example: Add V12 for 230 volt 1 phase Hydrovar input power supply

Add V34 for 460 volt 3 phase Hydrovar input power supply

4) The Packaged Price list adders are listed on page 6 in the e-SV Price book.

Note: The Package Price adders are also listed in the Variable Speed Pumping System Controller's Price book.

5) The complete Package Hydrovar list price will be the addition of the e-SV pump, motor, options, and the Packaged list price adder.

Packages are shipped completely assembled and prewired.

Packaged e-SV Hydrovar Options

	Suffix	Package Description
Addition of Package Hydrovar	V12	HYDROVAR 1PH 208-240V - 2HP
		HYDROVAR 1PH 208-240V - 3HP
		HYDROVAR 1PH 208-240V - 5HP
	V32	HYDROVAR 3PH 208-240V - 2HP
		HYDROVAR 3PH 208-240V - 3HP
		HYDROVAR 3PH 208-240V - 5HP
		HYDROVAR 3PH 208-240V - 7.5HP
		HYDROVAR 3PH 208-240V - 10HP
	V34	HYDROVAR 3PH 208-240V - 15HP
		HYDROVAR 3PH 380-460V - 2HP
		HYDROVAR 3PH 380-460V - 3HP
		HYDROVAR 3PH 380-460V - 5HP
		HYDROVAR 3PH 380-460V - 7.5HP
		HYDROVAR 3PH 380-460V - 10HP
		HYDROVAR 3PH 380-460V - 15HP
HYDROVAR 3PH 380-460V - 20HP		
HYDROVAR 3PH 380-460V - 25HP		
HYDROVAR 3PH 380-460V - 30HP		

- Hydrovar input power supply volts and phase are listed above.
- All Packaged e-SV Hydrovar systems use three phase TEFC TC frame Baldor motors.
- Master Hydrovar VSD is used on all packages.
- Fuse box contains Class J, Class CC or equal fast acting fuses.
- 300 PSI transducer is supplied as standard with package.
- Tanks, piping and valves sold separately.

Commercial Water

Packaged Hydrovar Kits

Packaged Hydrovar Kits are able to retrofit the e-SV, and other constant speed pumps in the field. Selections can be made for pumps up to 30 HP. The kits include the Hydrovar Master Drive, fused disconnect with bracket, wiring, conduit and 300 psi transducer. The Drive will be preprogrammed for single pump use. All the components are UR listed. The Kit will be fully assembled, prewired and packaged.

Building the Packaged Hydrovar Kit Order Number

Select Package Hydrovar Kit based on input power supply and existing pump motor HP

Note: The Order Number System is shown on page 5 in this book

All Packaged Hydrovars Kits are only to used with three phase TEFC motors

Kit includes Hydrovar Master Drive, fused disconnect with bracket, wiring and conduit

1-22SV

Model	Rated Output (HP)	Input Voltage (V)	Input Phase	Max Input Current (A)	Max Output Current (A)	Description
10073L1AAUST1KIT	2	208-240	1	11.6	7.5	Hydrovar Kit 2HP 1/208-240V
10073L2AAUST1KIT	3			15.1	10	Hydrovar Kit 3HP 1/208-240V
10073L4AAUST1KIT	5			27.6	16.7	Hydrovar Kit 5HP 1/208-240V
10073L5AAUST1KIT	2	208-240		7	7.5	Hydrovar Kit 2HP 3/208-240V
10073L6AAUST1KIT	3			9.1	10	Hydrovar Kit 3HP 3/208-240V
10073L8AAUST1KIT	5			16.5	16.7	Hydrovar Kit 5HP 3/208-240V
10073L9AAUST1KIT	7.5			23.5	24.2	Hydrovar Kit 7.5HP 3/208-240V
10073LAAAUST1KIT	10			29.6	31	Hydrovar Kit 10HP 3/208-240V
10073LBAAUST1KIT	15			43.9	44	Hydrovar Kit 15HP 3/208-240V
10073LCAAUST1KIT	2	380-460	3	3.9	4.1	Hydrovar Kit 2HP 3/380-460V
10073LDAAUST1KIT	3			5.3	5.7	Hydrovar Kit 3HP 3/380-460V
10073LFAAUST1KIT	5			10.1	10	Hydrovar Kit 5HP 3/380-460V
10073LGAAUST1KIT	7.5			12.8	13.5	Hydrovar Kit 7.5HP 3/380-460V
10073LHAAUST1KIT	10			16.9	17	Hydrovar Kit 10HP 3/380-460V
10073LLAAUST1KIT	15			24.2	24	Hydrovar Kit 15HP 3/380-460V
10073LMAAUST1KIT	20			33.3	32	Hydrovar Kit 20HP 3/380-460V
10073LNAAUST1KIT	25			38.1	38	Hydrovar Kit 25HP 3/380-460V
10073LPAAUST1KIT	30			44.7	44	Hydrovar Kit 30HP 3/380-460V

33-125SV

Model	Rated Output (HP)	Input Voltage (V)	Input Phase	Max Input Current (A)	Max Output Current (A)	Description
10073L4AAUST2KIT	5	208-240	1	27.6	16.7	Hydrovar Kit 5HP 1/208-240V
10073L8AAUST2KIT	5	208-240		16.5	16.7	Hydrovar Kit 5HP 3/208-240V
10073L9AAUST2KIT	7.5			23.5	24.2	Hydrovar Kit 7.5HP 3/208-240V
10073LAAAUST2KIT	10			29.6	31	Hydrovar Kit 10HP 3/208-240V
10073LBAAUST2KIT	15			43.9	44	Hydrovar Kit 15HP 3/208-240V
10073LFAAUST2KIT	5	380-460	3	10.1	10	Hydrovar Kit 5HP 3/380-460V
10073LGAAUST2KIT	7.5			12.8	13.5	Hydrovar Kit 7.5HP 3/380-460V
10073LHAAUST2KIT	10			16.9	17	Hydrovar Kit 10HP 3/380-460V
10073LLAAUST2KIT	15			24.2	24	Hydrovar Kit 15HP 3/380-460V
10073LMAAUST2KIT	20			33.3	32	Hydrovar Kit 20HP 3/380-460V
10073LNAAUST2KIT	25			38.1	38	Hydrovar Kit 25HP 3/380-460V
10073LPAAUST2KIT	30			44.7	44	Hydrovar Kit 30HP 3/380-460V



- Hydrovar input power supply volts and phase are listed above
- All Packaged Hydrovar kits are be only used on three phase TEFC TC frame Baldor motors
- Master Hydrovar Drive is used on all kits
- Fuse box contains class J or equal fast acting fuses
- 300 psi transducer is supplied as standard with kit

TECHNICAL DATA - PUMP HYDRAULICS / MOTOR SIZING

1SV 3500 RPM

No. of impellers	Maximum HP draw	Motor Selection using Hydrovar (1.0 SF)		Shutoff TDH (Feet)	Shutoff TDH (psi)	Shutoff TDH (Bar)	Casing / Sleeve Pressure Rating (standard assy.)	Pump Flange Rating	
		Rated HP	NEMA Motor Frame TEFC						
30	3.45	5.00	184TC	860	372	25.7	40 Bar (580 psi)	Class 250 / 300	
29	3.34		184TC	835	362	24.9			
28	3.22		184TC	810	351	24.2			
27	3.11		184TC	780	338	23.3			
26	2.99	3.00	56C	750	325	22.4			
25	2.88		56C	720	312	21.5			
24	2.76		56C	695	301	20.7			
23	2.67		56C	665	288	19.8			
22	2.53		56C	635	275	18.9			
21	2.42		56C	610	264	18.2			
20	2.3		56C	580	251	17.3			
19	2.19		56C	550	238	16.4			
18	2.07	2.00	56C	520	225	15.5			25 Bar (362 psi)
17	1.96		56C	485	210	14.5			
16	1.84		56C	455	197	13.6			
15	1.73		56C	425	184	12.7			
14	1.61	56C	400	173	11.9				
13	1.50	1.50	56C	375	162	11.2			
12	1.38		56C	345	149	10.3			
11	1.27		56C	315	136	9.4			
10	1.15		56C	290	126	8.7			
9	1.04		56C	255	110	7.6			
8	0.92	1.00	56C	230	100	6.9			
7	0.81		56C	200	87	6			
6	0.69	0.75	56C	175	76	5.2			
5	0.58		56C	145	63	4.3			
4	0.46	0.50	56C	115	50	3.4			
3	0.35		56C	85	37	2.5			
2	0.23		56C	60	26	1.8			

TECHNICAL DATA - PUMP HYDRAULICS / MOTOR SIZING

3SV 3500 RPM

No. of impellers	Maximum HP draw	Motor Selection using Hydrovar (1.0 SF)		Shutoff TDH (Feet)	Shutoff TDH (psi)	Shutoff TDH (Bar)	Casing / Sleeve Pressure Rating (standard assy.)	Pump Flange Rating
		Rated HP	NEMA Motor Frame TEFC					
30	6.24	7.50	213TC	1085	470	32.4	40 Bar (580 psi)	Class 250 / 300
29	6.03		213TC	1050	455	31.3		
28	5.82		213TC	1015	440	30.3		
27	5.62		213TC	975	422	29.1		
26	5.41		213TC	940	407	28		
25	5.20		213TC	900	390	26.9		
24	4.99	5.00	184TC	865	375	25.8	25 Bar (362 psi)	
23	4.78		184TC	825	357	24.6		
22	4.58		184TC	795	344	23.7		
21	4.37		184TC	760	329	22.7		
20	4.16		184TC	720	312	21.5		
19	3.95		184TC	680	294	20.3		
18	3.74		184TC	645	279	19.2		
17	3.54		184TC	610	264	18.2		
16	3.33		184TC	575	249	17.2		
15	3.12		184TC	540	234	16.1		
14	2.91	3.00	56C	500	217	14.9		
13	2.70		56C	465	201	13.9		
12	2.50		56C	430	186	12.8		
11	2.29		56C	395	171	11.8		
10	2.08		56C	360	156	10.7		
9	1.87	2.00	56C	320	139	9.5		
8	1.66		56C	285	123	8.5		
7	1.46	1.50	56C	250	108	7.5		
6	1.25		56C	215	93	6.4		
5	1.04		56C	180	78	5.4		
4	0.83	1.00	56C	145	63	4.3		
3	0.62	0.75	56C	105	45	3.1		
2	0.42	0.50	56C	70	30	2.1		

TECHNICAL DATA - PUMP HYDRAULICS / MOTOR SIZING

5SV 3500 RPM

No. of impellers	Maximum HP draw	Motor Selection using Hydrovar (1.0 SF)		Shutoff TDH (Feet)	Shutoff TDH (psi)	Shutoff TDH (Bar)	Casing / Sleeve Pressure Rating (standard assy.)	Pump Flange Rating
		Rated HP	NEMA Motor Frame TEFC					
27	8.80	10.00	215TC	975	422	29.1	40 Bar (580 psi)	Class 250 / 300
26	8.48		215TC	940	407	28		
25	8.15		215TC	900	390	26.9		
24	7.82		215TC	865	375	25.8		
23	7.50	7.50	213TC	825	357	24.6	25 Bar (362 psi)	
22	7.17		213TC	785	340	23.4		
21	6.85		213TC	745	323	22.2		
20	6.52		213TC	715	310	21.3		
19	6.19		213TC	685	297	20.4		
18	5.87		213TC	650	282	19.4		
17	5.54		213TC	615	266	18.4		
16	5.22	213TC	575	249	17.2			
15	4.89	5.00	184TC	540	234	16.1		
14	4.56		184TC	505	219	15.1		
13	4.24		184TC	470	204	14		
12	3.91		184TC	430	186	12.8		
11	3.59		184TC	395	171	11.8		
10	3.26		184TC	360	156	10.7		
9	2.93	3.00	56C	320	139	9.5		
8	2.61		56C	285	123	8.5		
7	2.28		56C	250	108	7.5		
6	1.96	2.00	56C	220	95	6.6		
5	1.63		56C	180	78	5.4		
4	1.3	1.50	56C	145	63	4.3		
3	0.98	1.00	56C	110	48	3.3		
2	0.65	0.75	56C	70	30	2.1		

Commercial Water

TECHNICAL DATA - PUMP HYDRAULICS / MOTOR SIZING

10SV 3500 RPM

No. of impellers	Maximum HP draw	Motor Selection using Hydrovar (1.0 SF)		Shutoff TDH (Feet)	Shutoff TDH (psi)	Shutoff TDH (Bar)	Casing / Sleeve Pressure Rating (standard assy.)	Pump Flange Rating
		Rated HP	NEMA Motor Frame TEFC					
20	17.84	20.00	256TC	1150	498	34.3	40 Bar (580 psi)	Victaulic
19	16.95		256TC	1095	474	32.7		
18	16.06		256TC	1035	448	30.9		
17	15.16		256TC	975	422	29.1		
16	14.27	15.00	254TC	920	398	27.5	25 Bar (362 psi)	Class 250 / 300
15	13.38		254TC	860	372	25.7		
14	12.49		254TC	805	349	24		
13	11.6		254TC	745	323	22.2		
12	10.7	254TC	690	299	20.6			
11	9.81	10.00	215TC	630	273	18.8		
10	8.92		215TC	575	249	17.2		
9	8.03		215TC	520	225	15.5		
8	7.14	7.50	213TC	460	199	13.7		
7	6.24		213TC	400	173	11.9		
6	5.35		213TC	340	147	10.1		
5	4.46	5.00	184TC	285	123	8.5		
4	3.57		184TC	225	97	6.7		
3	2.68	3.00	56C	170	74	5.1		
2	1.78	2.00	56C	115	50	3.4		
1	0.89	1.00	56C	60	26	1.8		

15SV 3500 RPM

No. of impellers	Maximum HP draw	Motor Selection using Hydrovar (1.0 SF)		Shutoff TDH (Feet)	Shutoff TDH (psi)	Shutoff TDH (Bar)	Casing / Sleeve Pressure Rating (standard assy.)	Pump Flange Rating
		Rated HP	NEMA Motor Frame TEFC					
15	28.50	30.00	286TC	1060	459	31.6	40 Bar (580 psi)	Class 250 / 300
14	26.60		286TC	990	429	29.5		
13	24.70	25.00	284TC	915	396	27.3		
12	22.80		284TC	850	368	25.4		
11	20.90		284TC	780	338	23.3		
10	19.00	20.00	256TC	705	305	21	25 Bar (362 psi)	
9	17.10		256TC	635	275	18.9		
8	15.20		256TC	565	245	16.9		
7	13.30	15.00	254TC	485	210	14.5		
6	11.40		254TC	420	182	12.5		
5	9.50	10.00	215TC	345	149	10.3		
4	7.60		215TC	275	119	8.2		
3	5.70		7.50	213TC	210	91		
2	3.80	5.00	184TC	140	61	4.2		
1	1.90	2.00	56C	70	30	2.1		

TECHNICAL DATA - PUMP HYDRAULICS / MOTOR SIZING

22SV 3500 RPM

No. of impellers	Maximum HP draw	Motor Selection using Hydrovar (1.0 SF)		Shutoff TDH (Feet)	Shutoff TDH (psi)	Shutoff TDH (Bar)	Casing / Sleeve Pressure Rating (standard assy.)	Pump Flange Rating
		Rated HP	NEMA Motor Frame TEFC					
12	28.92	30.00	286TC	880	381	26.3	40 Bar (580 psi)	Class 250 / 300
11	26.51		286TC	810	351	24.2		
10	24.10	25.00	284TC	735	318	21.9	25 Bar (362 psi)	
9	21.69		284TC	660	286	19.7		
8	19.28	20.00	256TC	585	253	17.5		
7	16.87		256TC	515	223	15.4		
6	14.46	15.00	254TC	440	191	13.1		
5	12.05		254TC	365	158	10.9		
4	9.64	10.00	215TC	295	128	8.8		
3	7.23	7.50	213TC	220	95	6.6		
2	4.82	5.00	184TC	145	63	4.3		
1	2.41	3.00	56C	70	30	2.1		

33SV 3500 RPM

# of Impellers / # Reduced Diameter	Maximum HP Draw	Motor Selection using Hydrovar (1.0 SF)		Shutoff TDH (Feet)	Shutoff TDH (psi)	Shutoff TDH (Bar)	Casing / Sleeve Pressure rating (Standard Assy.)	Stages Requiring Thrust Balancing Piston	Pump Flange Rating
		Rated HP	NEMA Motor Frame TEFC						
6/2	29	30	286TC	617	267	18	25 Bar (362 PSI)	Thrust Piston Required	Class 250 / 300
5	27			562	244	17			
5/1	25			533	231	16			
5/2	24	25	284TC	504	219	15			
4	21			450	195	13			
4/1	20	20	256TC	421	183	13			
4/2	18			392	170	12			
3	16			337	146	10			
3/1	14	15	254TC	310	310	9			
3/2	13			281	135	8			
2	10			225	98	7			
2/1	9	10	215TC	196	85	6			
2/2	7			167	73	5			
1	5	7.5	213TC	113	49	3			
1/1	4			84	37	3			

Commercial Water

TECHNICAL DATA - PUMP HYDRAULICS / MOTOR SIZING

46SV 3500 RPM

# of Impellers / # Reduced Diameter	Maximum HP Draw	Motor Selection using Hydrovar (1.0 SF)		Shutoff TDH (Feet)	Shutoff TDH (psi)	Shutoff TDH (Bar)	Casing / Sleeve Pressure rating (Standard Assy.)	Stages Requiring Thrust Balancing Piston	Pump Flange Rating
		Rated HP	NEMA Motor Frame TEFC						
4/2	29	30	286TC	453	197	13.5	25 Bar (362 PSI)	Thrust Piston Required	Class 250 / 300
3	24.4	25	284TC	379	164	11.3		Class 125 / 150	
3/1	22.7			353	153	10.5			
3/2	20.9			327	142	9.8			
2	16.3	20	256TC	253	110	7.6			
2/1	14.5	15	254TC	226	98	6.7			
2/1	12.8			200	87	6			
1	8.5	10	215TC	127	55	3.8			
1/1	6.7	7.5	213TC	102	45	3			

66SV 3500 RPM

# of Impellers / # Reduced Diameter	Maximum HP Draw	Motor Selection using Hydrovar (1.0 SF)		Shutoff TDH (Feet)	Shutoff TDH (psi)	Shutoff TDH (Bar)	Casing / Sleeve Pressure rating (Standard Assy.)	Pump Flange Rating
		Rated HP	NEMA Motor Frame TEFC					
3/2	30.6	30	286TC	372	161	11.1	25 Bar (362 PSI)	Class 125 / 150
2	24.4	25	284TC	283	123	8.4		
2/1	21.4			257	112	7.7		
2/2	18.4	20	256TC	230	100	6.9		
1	12.2	15	254TC	142	62	4.2		
1/1	9.2	10	215TC	115	50	3.4		

92SV 3500 RPM

# of Impellers / # Reduced Diameter	Maximum HP Draw	Motor Selection using Hydrovar (1.0 SF)		Shutoff TDH (Feet)	Shutoff TDH (psi)	Shutoff TDH (Bar)	Casing / Sleeve Pressure rating (Standard Assy.)	Pump Flange Rating
		Rated HP	NEMA Motor Frame TEFC					
2/1	27.4	30	286TC	278	121	8.3	25 Bar (362 PSI)	Class 125 / 150
2/2	23.4	25	284TC	253	110	7.6		
1	15.5	20	256TC	151	66	4.5		
1/1	12	15	254TC	127	55	3.8		

125SV 3500 RPM

No. of impellers	Maximum HP draw	Motor Selection using Hydrovar (1.0 SF)		Shutoff TDH (Feet)	Shutoff TDH (psi)	Shutoff TDH (Bar)	Casing / Sleeve Pressure Rating (standard assy.)	Pump Flange Rating
		Rated HP	NEMA Motor Frame TEFC					
1/0C	17.40	20	256TC	131	57	3.9	25 Bar (362 PSI)	Class 125 / 150

MOTOR DATA

HP	Phase	Voltage	FLA	Enclosure	Order No.	Frame Size
2	3	208-230/460	6.2-5.8/2.9	TPE	V08A32E5BB2S	56C
		230/460	5/2.5		V08A32F5BB2S	
3		208-230/460	8.1-7.6/3.8		V09A32E5BB2S	
		230/460	7/3.5		V09A32F5BD2S	
5		208-230/460	13.2-12/6		V10A32E5BD2S	184TC
		230/460	11.2/5.6		V10A32F5BD2S	
7 1/2		208-230/460	18.5-17.4/8.7		V11A32E5BD2S	213TC
		230/460	17.8/8.9		V11742APE	
10		208-230/460	26.2-23.8/11.9		V12A32E5BE2S	215TC
		230/460	23.8/11.9		V12A32F5BE2S	
15		208-230/460	38-35/17.5		V13A32E5BK2S	254TC
		230/460	34/17		V13A32F5BK2S	
20		208-230/460	50-46/23		V14A32E5BK2S	256TC
		230/460	49/22.5		V14A32F5BK2S	
25		208-230/460	61-57/28.5		V15A32E5BL2S	284TC
		208-230/460	60-56/28		V15A32F5BL2S	
30	208-230/460	74-68/34	V16A32E5BL2S			
	230/460	68/34	V16A32F5BL2S			

NOTES:

Above data is for Baldor® TC and TSC frame motors. Specifications subject to change without notice.

Commercial Water

PACKAGED HYDROVAR SERIES – 1SV - 22SV DIMENSIONS

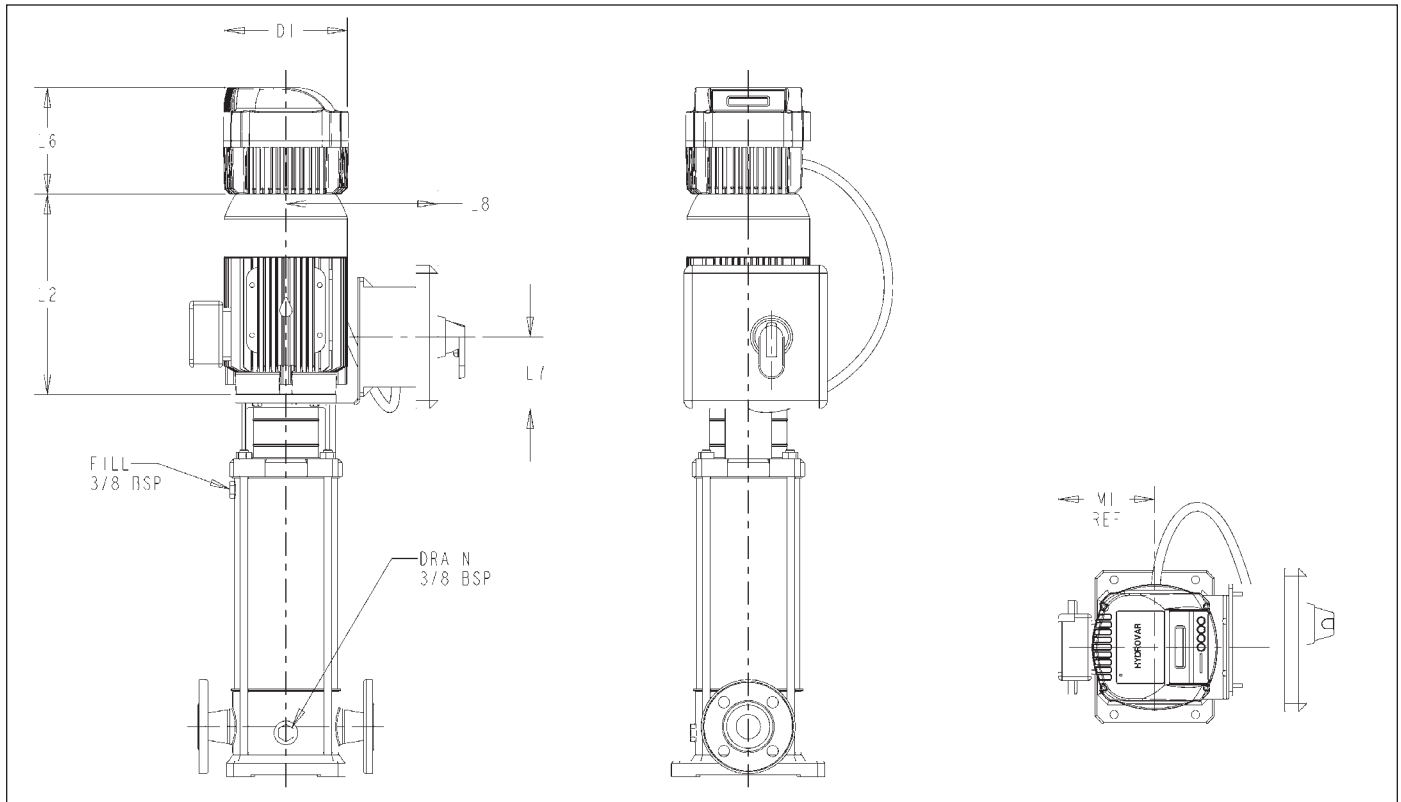

Motor Frame (3 PH TEFC)	HP	Hydrovar Model	Disconnect Box Model	Dimensions (in)						Weight (lbs.)	
				L2	L6	L7	L8 (Ref.)	MI (Ref.)	DI Max.	Hydrovar	Disconnect Box
56C	2	A	A	10.79	6.7	4.69	11.5	5.74	8.07	12.35	3.6
	3			11.16							
184TC	5	A (460V/3Ph)	A (460V/3Ph)	13.93	7.29	5.69	12.5	8.05	10.43	23.15	8.2
		B (230V/3Ph)	A (230V/3Ph)								
		B (230V/1Ph)	B (230V/1Ph)								
213TC	7.5	B	A (460V/3Ph)	15.43	7.29	4.69	11.5	8.77	10.43	23.15	3.6
			B (230V/3Ph)								
215TC	10	B (460V/3Ph)	A (460V/3Ph)	15.51	7.88	5.69	12.5	8.77	13.27	34.39	8.2
		C (230V/3Ph)	B (230V/3Ph)								
254TC	15	B (460V/3Ph)	A (460V/3Ph)	16.57	7.29	4.69	11.5	9.22	10.43	23.15	3.6
		C (230V/3Ph)	B (230V/3Ph)								
256TC	20	C	B	20.08	7.88	5.69	12.5	9.5	13.27	34.39	8.2
284TC	25	C	B	19.54							
286TC	30	C	B	23.18							

NOTE: See e-SV Technical Manual for Liquid-End Dimensions.

PACKAGED HYDROVAR SERIES – 33SV - 92SV DIMENSIONS

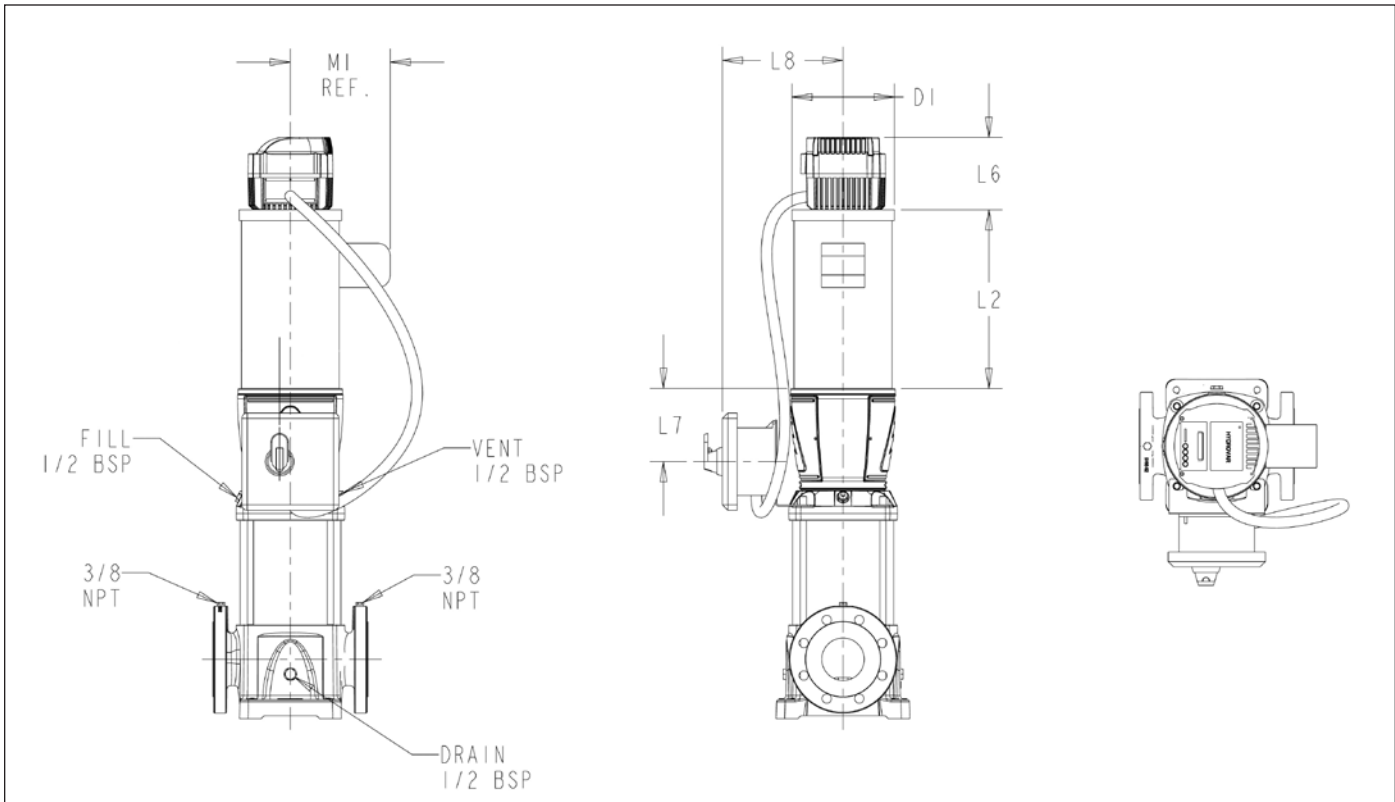

Motor Frame (3 PH TEFC)	HP	Hydrovar Model	Disconnect Box Model	Dimensions (in)						Weight (lbs.)	
				L2	L6	L7	L8 (Ref.)	MI (Ref.)	DI Max.	Hydrovar	Disconnect Box
184TC	5	A (460V/3Ph)	A (460V/3Ph)	13.93	6.7	4.69	11.5	8.05	8.07	12.35	3.6
		B (230V/3Ph)	A (230V/3Ph)								
		B (230V/1Ph)	B (230V/1Ph)								
213TC	7.5	B	A (460V/3Ph)	15.43	7.29	4.69	11.5	8.05	10.43	23.15	3.6
			B (230V/3Ph)								B (230V/3Ph)
215TC	10	B (460V/3Ph)	A (460V/3Ph)	15.51	7.88	5.69	12.5	8.77	13.27	34.39	3.6
		C (230V/3Ph)	B (230V/3Ph)								8.2
254TC	15	B (460V/3Ph)	A (460V/3Ph)	16.57	7.29	4.69	11.5	9.22	10.43	23.15	3.6
		C (230V/3Ph)	B (230V/3Ph)								8.2
256TC	20	C	B	20.08	7.88	5.69	12.5	9.5	13.27	34.39	8.2
284TC	25	C	B	19.54							
286TC	30	C	B	23.18							

NOTE: See e-SV Technical Manual for Liquid-End Dimensions.

e-SVE: VERSION WITH SMART MOTOR

Background and context

In every sector, from construction and industry to agriculture and building services the need for intelligent, compact and high-efficiency pumping systems is constantly growing.

That's why Goulds Water Technology has developed the e-SVE series: an integrated intelligent pumping system with electronically driven, ultra-premium IE5, permanent magnet motor.

The integrated control system, combined with the high performance, power and efficiency from the motor and hydraulics, guarantees impressively low operating costs. You also benefit from flexibility, precision and its ultra-compact size.

Savings

The electronics and permanent magnet motor are highly efficient and minimize power losses while transferring maximum energy to the hydraulic parts of the pump.

The refined control system with integrated microprocessor adjusts the motor speed, matching the required operating point of the pump or system requirements.

This reduces demand on electricity according to the required working conditions.

This creates economies, especially in systems where pump demand varies over time.

Flexibility

The compact size, low loss and increased control make the e-SVE series a good choice in applications and systems where fixed speed pumps are commonly used. The e-SVE series is easy to integrate in control and regulation loops thanks to the wide availability of compatible communication protocols, including analog and digital inputs.

The pump is supplied with a pressure sensor.

Ease of use and commissioning

e-SVE has an intuitive interface that guides the user through the installation, and a practical area to assist with connections.

The control system is integrated and no additional external electrical panel is required.

Application sectors

- Water supply systems in residential buildings
- Air conditioning/HVAC
- Water treatment plants
- Industrial installations
- Light commercial
- Agriculture
- OEM

e-SVE (Smart Motor with e-SV Pump)

- Delivery: Up to 75 gpm (17 m³/h)
- Head: Up to 710 feet (215 m)
- Liquid temperature: Up to 250°F (120°C)
- Maximum operating pressure
 - SV1-10 with oval flanges: 230 psi (16 bar)
 - SV1-10 with round flanges or Victaulic: 360 or 575 psi (25 or 40 bar)
- Power range: 0.5-3 HP (0.37 - 2.2 kW)

The e-SV pump is a non-self priming vertical multistage pump. The liquid end, located between the upper cover and the pump casing, is held in place by tie rods. The pump casing is available with different configurations and connection types.

Smart Motor

- Voltage: single phase 208-230V to 2 HP, three phase 208-230/460V to 2 HP, three phase 380-460V to 3 HP
- Power: up to 3 HP (2.2 kW)
- Multipump capability: up to 3 units
- Power supply: 50/60 Hz
- Comms: BACnet and Modbus standard for single pumps
- Motor: IES2 package with IE5 motors
- Enclosure rating: IP55 / NEMA 3R
- Ambient temperature: -4°F/ 122°F (20°C / +50°C) full power
- EMC: single phase C1



e-SVE NAMEPLATE

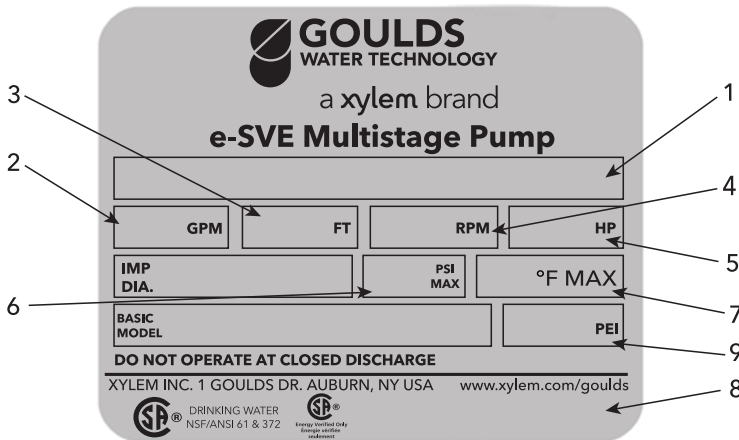

1	Catalog Number
2	Capacity Range
3	TDH Range
4	Rated Speed
5	Rated Horsepower
6	Maximum Operating Pressure
7	Maximum Fluid Temp (°F)
8	Pump Serial Number
9	PEI = Pump Efficiency Index

e-SVE SERIES: PUMP WITH DRIVE AND SMART MOTOR (PERMANENT MAGNET MOTOR)

Product Code for 1-10 SVE Pump & Motor Combination

Each e-SVE pump is identified by a product code on the pump label. Each digit in the code is described below. The product code is also the catalog number for the pump. **Note: Not all combinations are possible.**

Example Product Code

10 SVE 2 2 F A 3 B M 0 F H

Special Configurations (1 or 2 Characters)
 P = Passivation only
 S = Customized Configuration
 Z = High Press (250/300# pump body)

Seal Material
 0 = Carb-SilCar-Viton
 1 = Carb-SilCar-AFLAS (HighTemp)
 2 = SilCar-SilCar-Viton
 4 = SilCar-SilCar-EPR
 6 = Carb-SilCar-EPR

Motor Enclosure
 M = eSM

Voltage
 F = 208-230/460
 N = 380 - 460 (3 HP only)
 L = 208-230

Pole-Hz-Phase
 3 = 2-60-1
 4 = 2-60-3

HP Rating
 A = 0.50
 B = 0.75
 C = 1.00
 D = 1.50
 E = 2
 F = 3

Configuration OPTION
 C = Clamp-316
 F = Round-304 (SVB)
 G = CI-304
 N = Round-316 (SVD)
 P = Victaulic-316
 T = Oval-304 (SVA)
 R = (SVC) 12Suct-12Disch
 W = (SVC) 12Suct-03Disch
 X = (SVC) 12Suct-06Disch
 Y = (SVC) 12Suct-09Disch

Total Number of Impeller Stages (may be 1 or 2 characters)
 Please refer to pages 111 - 133 for more staging information.

Product Line:
 SVE - Stainless Vertical

Nominal Flow:
 1 = 5 GPM
 3 = 16 GPM
 5 = 26 GPM
 10 = 53 GPM

Bottom / Top
 Suction discharge location

Commercial Water

e-SVE

e-SVE series is equipped with an intelligent control that optimizes hydraulic performance while minimizing waste.

Integrated intelligence: The electronic control of the motor enables a 20% increase in performance compared to an equivalent fixed speed pump.

Extended working performances

(smart hydraulic curve vs. previous solution with TKS)

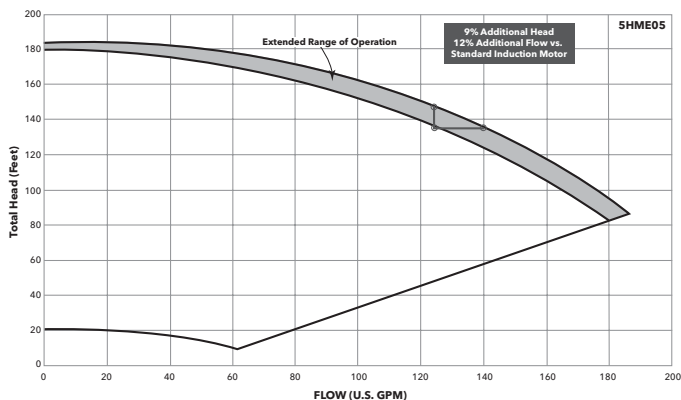

Controls, safety features and monitoring tools

Available control modes include:

- Control for constant pressure
- Control to match a system curve
- Control according to an external signal

In addition to these regulation functions, the Smart Motor also:

- Stops the pump at zero demand
- Stops the pump in case of water failure
- Allows protection against dry running
- Has failure and over-temperature sensors for both the inverter and motor, which protects the pump and motor from under or over-voltage

Intuitive and simple interface: You can control the unit from just three buttons, with an easy to read display for parameters and alarms, designed for complete control of system operation.

- ① Communication LED
- ② Power on LED
- ③ Unit of measure LED
- ④ Speed LED bar
- ⑤ Status LED
- ⑥ Numeric display
- ⑦ Decrease key
- ⑧ On/off and menu key
- ⑨ Increase key

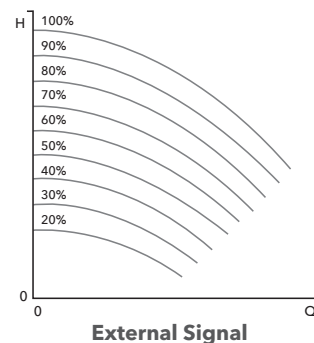
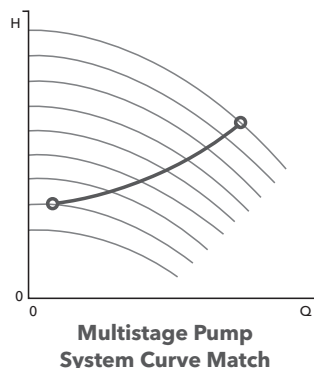
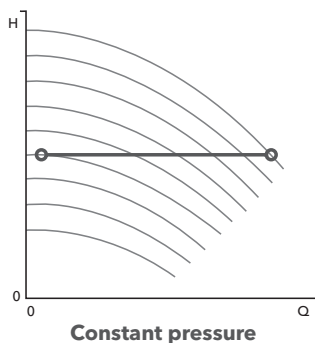
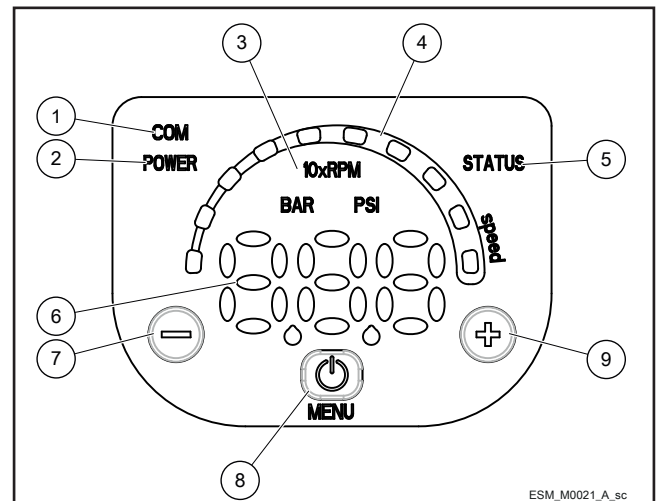

e-SVE Hydraulic Coverage Curve

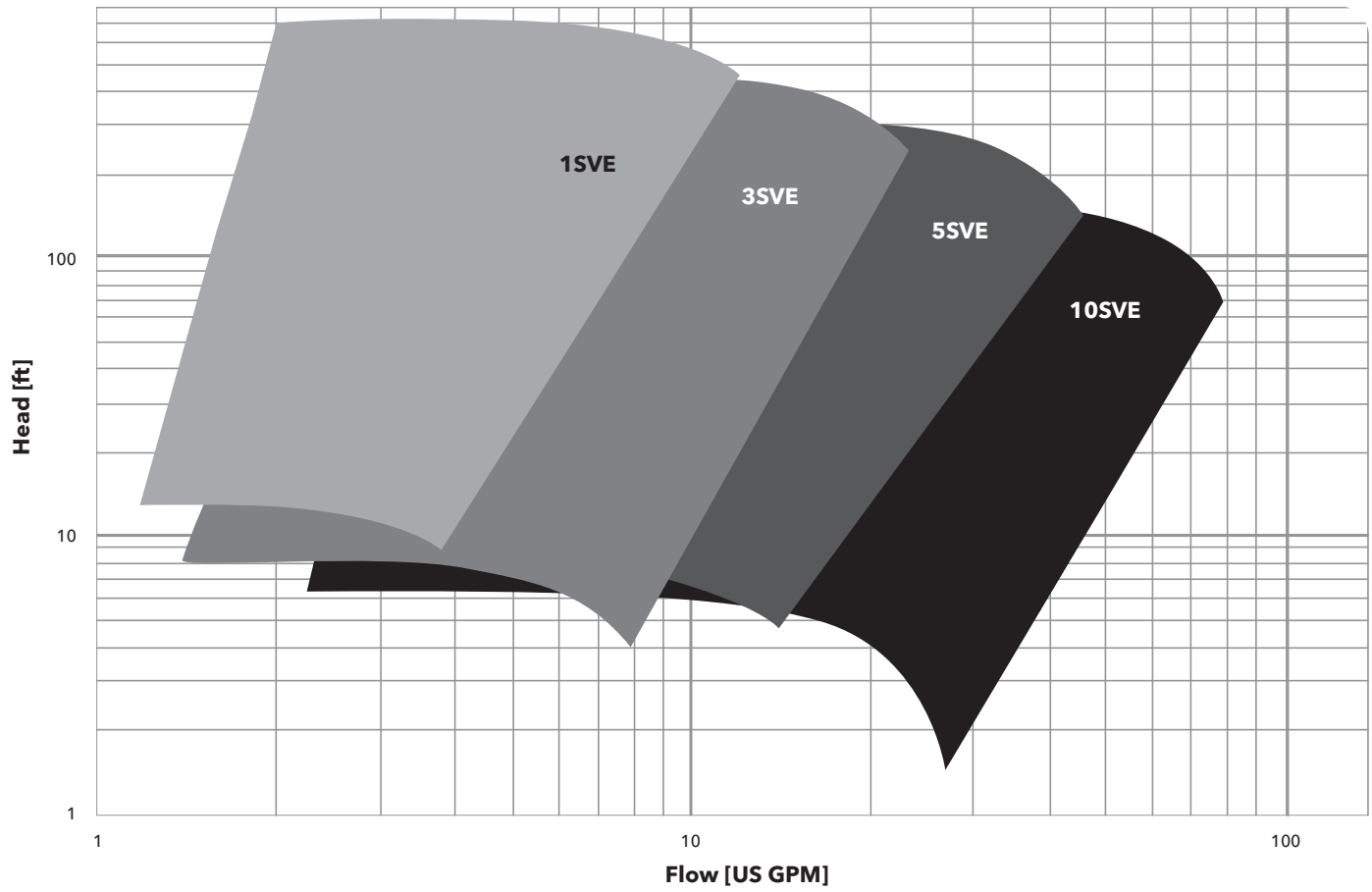

Commercial Water

e-SVE SERIES SINGLE PHASE TERMINAL BLOCK

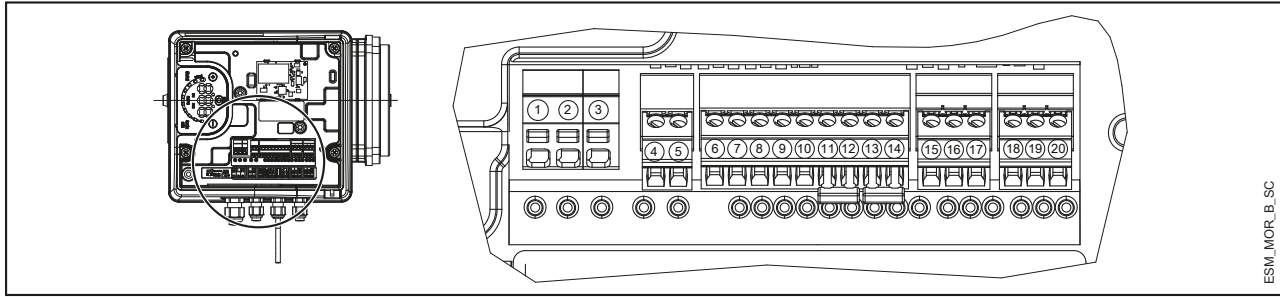

ESM_MOR_B_SC

REF.	ITEM	DESCRIPTION
4	Fault Signal	COM - error status relay
5		NO - error status relay
6	Auxiliary Voltage Supply	Auxiliary voltage supply +15 VDC
7	Analog input 0-10V	Actuator mode 0-10 V input
8		GND for 0-10 V input
9	External Pressure sensor [also Differential]	Power supply external sensor +15 VDC
10		External sensor 4-20 mA input
11	External Start/Stop	External ON/OFF input reference
12		External ON/OFF input
13	External Lack of Water	Low water input
14		Low water reference
15	Communication bus	RS485 port 1: RS485-1N B (-)
16		RS485 port 1: RS485-1P A (+)
17		Electronic GND
18	Communication bus	RS485 port 2: RS485 port 2: RS485-2N B (-) active only with optional module
19		RS485 port 2: RS485 port 2: RS485-2P A (+) active only with optional module
20		Electronic GND

MorsM-en_a_sc

THREE-PHASE TERMINAL BLOCK

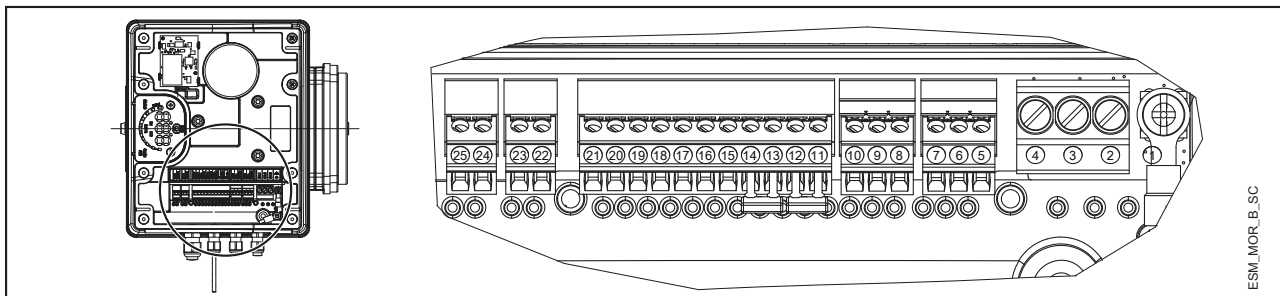

ESM_MOR_B_SC

REF.	ITEM	DESCRIPTION
5	Communication bus	Electronic GND
6		RS485 port 1: RS485-1P A (+)
7	Communication bus	RS485 port 1: RS485-1N B (-)
8		Electronic GND
9	Communication bus	RS485 port 2: RS485 port 2: RS485-2P A (+) active only with optional module
10		RS485 port 2: RS485 port 2: RS485-2N B (-) active only with optional module
11	External Lack of Water	Low water reference
12		Low water input
13	External Start/Stop	External ON/OFF input reference
14		External ON/OFF input
15	External Pressure sensor	External sensor 4-20 mA input
16		Power supply external sensor +15 VDC
17	External Pressure sensor [also Differential]	External sensor 4-20 mA input
18		Power supply external sensor +15 VDC
19	Analog input 0-10V	GND for 0-10 V input
20		Actuator mode 0-10 V input
21	Auxiliary Voltage Supply	Auxiliary voltage supply +15 VDC
22	Motor running signal	Normally open contact
23		Common contact
24	Fault Signal	NO - error status relay
25		COM - error status relay

MorsT-en_a_sc

e-SVE SERIES HOW TO READ SMART PUMP SERIES CURVES

To exploit to the maximum potential of Smart Pumps it's important to properly read working curves:

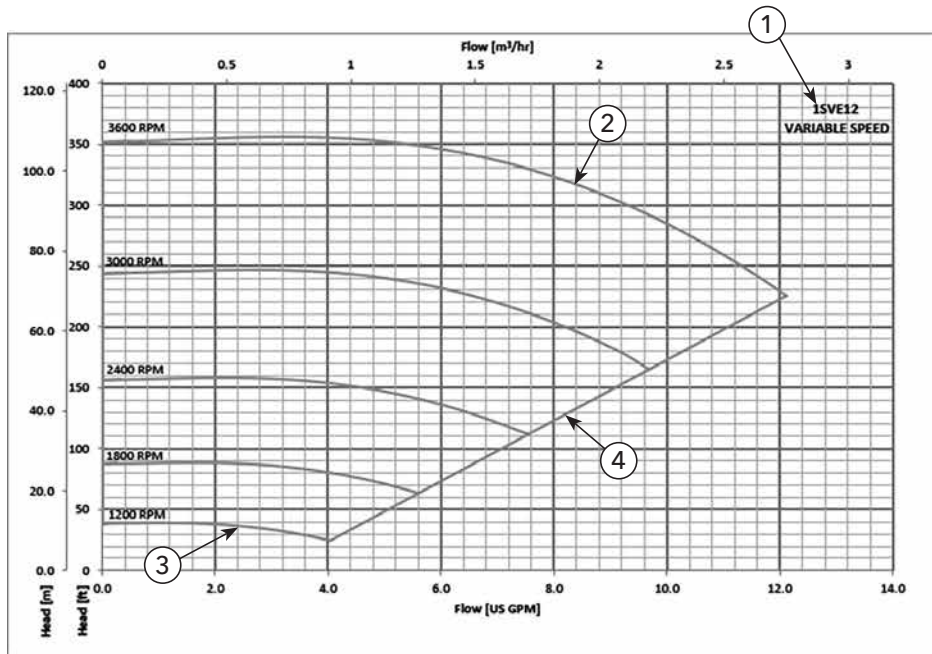

① **Pump model**

② **Maximum speed curve:** equal to 3600 rpm.

③ **Minimum speed curve:** the minimum rpm level of the motor.

④ Each **intermediate curve** between max and min speed shows the speed in rpm the pump+motor+drive system is working at; it's easy to read also from the LED speed bar on the HMI keypad: at 90% there will be 9 LED, at 80% there will be 8 and so on.

Example: at 50% (1800 rpm) there will be 5 LEDs lit.

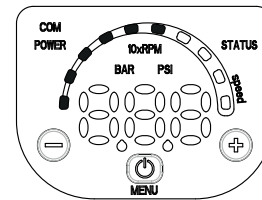
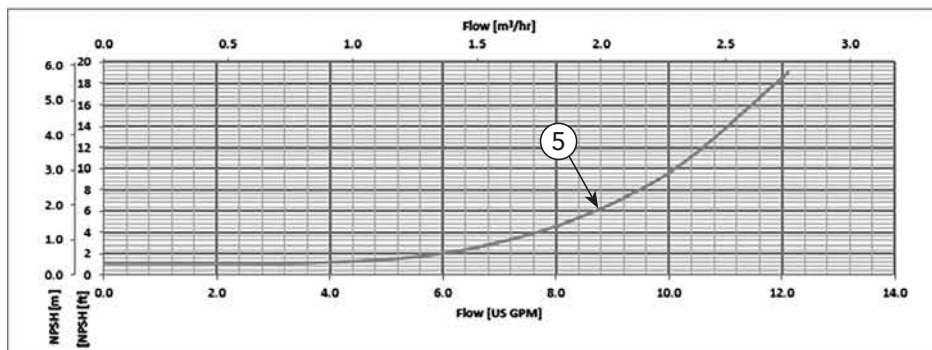

⑤ **NPSH:** is the net positive suction head of pump+motor+drive system working at maximum speed.

⑥ **Wire to Water Efficiency** is the efficiency of pump+motor+drive system working at maximum speed.

⑦ **Pump Efficiency** is the efficiency of the hydraulic part, working at maximum speed.

⑧ **Working point:** it's important to make sure the pump is working at the best working point, the one at highest efficiency.

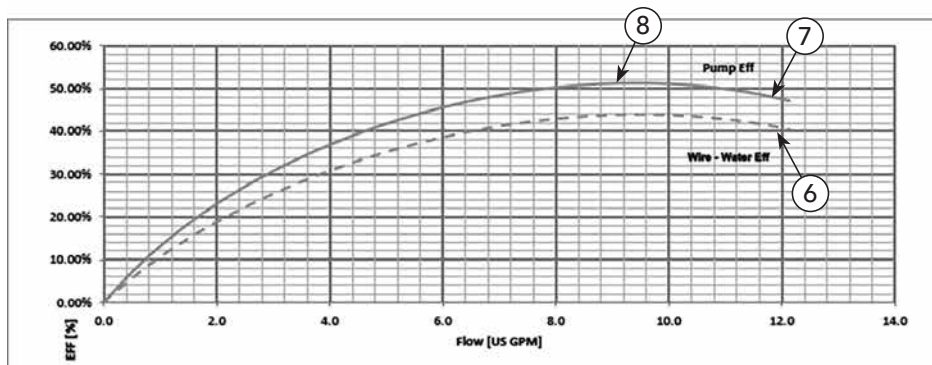

The performances are valid for liquid with density $\rho = 1 \text{ Kg/dm}^3$ and kinematic viscosity $\nu = 1 \text{ mm}^2/\text{sec}$.

It's easy to find it: it's the highest point of the hp pump efficiency curve; once you found it, you can read flow values from x-axis and head values from y-axis which allow the system to work at the best working point.

e-SVE SERIES - SINGLE-PHASE VERSION

PUMP TYPE SVE Single-Phase	MOTOR		PUMP UNIT	
	P _N (HP)	Type 1 x 208-240 V	* P1 (kW) 1 x 208-240 V	I (A) 1 x 208-240 V
1SVE4	0.5	ESM90R/103 SVE	0.49	2.3 - 2.0
1SVE6	0.75	ESM90R/105 SVE	0.69	3.3 - 2.9
1SVE8	1.0	ESM90R/107 SVE	0.91	4.4 - 3.8
1SVE12	1.5	ESM90R/111 SVE	1.33	6.2 - 5.3
1SVE17	2.0	ESM90R/115 SVE	1.77	8.4 - 7.3

PUMP TYPE SVE Single-Phase	MOTOR		PUMP UNIT	
	P _N (HP)	Type 1 x 208-240 V	* P1 (kW) 1 x 208-240 V	I (A) 1 x 208-240 V
3SVE2	0.5	ESM90R/103 SVE	0.49	2.1 - 1.8
3SVE3	0.75	ESM90R/105 SVE	0.69	3.3 - 2.9
3SVE4	1.0	ESM90R/107 SVE	0.91	4.4 - 3.8
3SVE6	1.5	ESM90R/111 SVE	1.33	7.5 - 6.4
3SVE9	2.0	ESM90R/115 SVE	1.77	8.4 - 7.3

PUMP TYPE SVE Single-Phase	MOTOR		PUMP UNIT	
	P _N (HP)	Type 1 x 208-240 V	* P1 (kW) 1 x 208-240 V	I (A) 1 x 208-240 V
5SVE2	0.75	ESM90R/105 SVE	0.49	3.3 - 2.9
5SVE3	1.0	ESM90R/107 SVE	0.69	4.4 - 3.8
5SVE4	1.5	ESM90R/111 SVE	0.91	7.8 - 6.7
5SVE6	2.0	ESM90R/115 SVE	1.33	8.4 - 7.3

PUMP TYPE SVE Single-Phase	MOTOR		PUMP UNIT	
	P _N (HP)	Type 1 x 208-240 V	* P1 (kW) 1 x 208-240 V	I (A) 1 x 208-240 V
10SVE1	1.0	ESM90R/107 SVE	0.86	4.2 - 3.6
10SVE2	2.0	ESM90R/115 SVE	1.33	7.9 - 6.8

* Maximum value in specified range; P_N = HP Rating; P1 = input power; I = input current.

e-SVE SERIES - THREE-PHASE VERSION

PUMP TYPE SVE Three-Phase	MOTOR		PUMP UNIT		
	P _N (HP)	Type 1 x 208-240 V	* P1 (kW)	I (A) 208-240 V	I (A) 380-460 V
1SVE4	0.5	ESM90R/303 SVE	0.47	2.1 - 1.8	1.4 - 1.3
1SVE6	0.75	ESM90R/305 SVE	0.68	2.9 - 2.5	1.9 - 1.7
1SVE8	1.0	ESM90R/307 SVE	0.9	3.7 - 3.3	2.4 - 2.2
1SVE12	1.5	ESM90R/311 SVE	1.34	5.2 - 4.7	3.5 - 3.1
1SVE17	2.0	ESM90R/315 SVE	1.78	6.7 - 6.1	4.5 - 4.0
1SVE24	3.0	ESM90R/322 SVE	2.55	-	5.9 - 5.2

PUMP TYPE SVE Three-Phase	MOTOR		PUMP UNIT		
	P _N (HP)	Type 1x230 V	* P1 (kW)	I (A) 208-240 V	I (A) 380-460 V
3SVE2	0.5	ESM90R/303 SVE	0.42	1.9 - 1.6	1.3 - 1.2
3SVE3	0.75	ESM90R/305 SVE	0.68	2.9 - 2.5	1.9 - 1.7
3SVE4	1.0	ESM90R/307 SVE	0.9	3.7 - 3.3	2.4 - 2.2
3SVE6	1.5	ESM90R/311 SVE	1.6	6.0 - 5.5	4.0 - 3.6
3SVE9	2.0	ESM90R/315 SVE	1.78	6.7 - 6.1	4.5 - 4.0
3SVE13	3.0	ESM90R/322 SVE	2.55	-	5.9 - 5.2

PUMP TYPE SVE Three-Phase	MOTOR		PUMP UNIT		
	P _N (HP)	Type 1x230 V	* P1 (kW)	I (A) 208-240 V	I (A) 380-460 V
5SVE2	0.75	ESM90R/305 SVE	0.68	2.9 - 2.5	1.9 - 1.7
5SVE3	1.0	ESM90R/307 SVE	0.9	3.7 - 3.3	2.4 - 2.2
5SVE4	1.5	ESM90R/311 SVE	1.71	6.3 - 5.7	4.2 - 3.7
5SVE6	2.0	ESM90R/315 SVE	1.78	6.7 - 6.1	4.5 - 4.0
5SVE9	3.0	ESM90R/322 SVE	2.55	-	5.9 - 5.2

PUMP TYPE SVE Three-Phase	MOTOR		PUMP UNIT		
	P _N (HP)	Type 1x230 V	* P1 (kW)	I (A) 208-240 V	I (A) 380-460 V
10SVE1	1.0	ESM90R/307 SVE	0.87	3.6 - 3.2	2.3 - 2.1
10SVE2	2.0	ESM90R/315 SVE	1.67	6.3 - 5.7	4.2 - 3.7
10SVE3	3.0	ESM90R/322 SVE	2.34	-	5.4 - 4.8

* Maximum value in specified range; P_N = HP Rating; P1 = input power; I = input current.

Commercial Water

e-SVE SERIES - ELECTRICAL DATA TABLE

The nominal motor power is guaranteed in the 3000-3600 rpm range. The motor is automatically limited to 3600 rpm maximum; the motor works partially loaded below 3000 rpm.

SINGLE-PHASE VERSION

PN HP	MOTOR TYPE	IEC SIZE	Construction Design	SPEED (RPM)* min-1	INPUT CURRENT I (A) 208-240 V	DATA RELATED TO 230V					
						In A	Power Factor / cos φ	Tn lb.ft	Efficiency η %		
									100	75	50
0.50	ESM90R/103 SVE	90R	SPECIAL	3000	2.28-1.99	2.08	0.95	0.87	81.3	79.1	74.3
				3600	2.30-2.02	2.10		0.72	80.6	77.5	72.0
0.75	ESM90R/105 SVE			3000	3.27-2.85	2.96	0.97	1.29	83.3	82.2	78.8
				3600	3.27-2.85	2.96		1.08	83.3	81.5	77.5
1.0	ESM90R/107 SVE			3000	4.43-3.84	4.00	0.98	1.76	83.3	83.3	81.5
				3600	4.38-3.79	3.94		1.47	84.5	83.5	80.6
1.5	ESM90R/111 SVE			3000	6.26-5.35	5.64	0.99	2.58	85.7	85.1	82.7
				3600	6.20-5.32	5.63		2.15	85.9	84.6	81.4
2.0	ESM90R/115 SVE			3000	8.57-7.32	7.69	0.99	3.52	85.6	85.7	84.7
				3600	8.42-7.25	7.62		2.94	86.3	85.9	84.0

* The indicated rotational speeds represent the upper and lower limits of the speed range for rated power.

THREE-PHASE VERSION

PN HP	MOTOR TYPE	IEC SIZE	Construction Design	SPEED (RPM)* min-1	INPUT CURRENT I (A) 208-240/380- 460 V	DATA RELATED TO 460V					
						In A	Power Factor / cos φ	Tn lb.ft	Efficiency η %		
									100	75	50
0.50	ESM90R/303 SVE	90R	SPECIAL	3000	2.01-1.85/1.41-1.28	1.28	0.45	1.18	81.0	78.6	74.0
				3600	2.13-1.83/1.43-1.33	1.33		0.98	76.3	72.5	65.8
0.75	ESM90R/305 SVE			3000	2.81-2.57/1.89-1.69	1.69	0.50	1.75	82.8	81.5	78.6
				3600	2.90-2.52/1.90-1.73	1.73		1.46	80.1	77.5	72.4
1.0	ESM90R/307 SVE			3000	3.70-3.37/2.44-2.17	2.17	0.52	2.39	83.1	82.8	81.0
				3600	3.74-3.28/2.43-2.20	2.20		1.99	81.9	80.2	76.5
1.5	ESM90R/311 SVE			3000	5.12-4.73/3.41-3.01	3.01	0.55	3.50	83.9	82.9	80.2
				3600	5.15-4.69/3.45-3.06	3.06		2.92	82.2	80.1	75.7
2.0	ESM90R/315 SVE			3000	6.73-6.17/4.49-3.95	4.39	0.59	3.52	83.9	84.0	82.4
				3600	6.69-6.08/4.48-3.97	4.32		2.94	83.4	82.3	79.3
3.0	ESM90R/322 SVE			3000	- /6.03-5.32	5.32	0.60	7.00	86.9	86.7	85.1
				3600	- /5.93-5.24	5.24		5.84	88.2	87.4	85.3

* The indicated rotational speeds represent the upper and lower limits of the speed range for rated power.

1, 3, 5SVE SERIES - SINGLE PHASE VERSION DIMENSIONS AND WEIGHTS

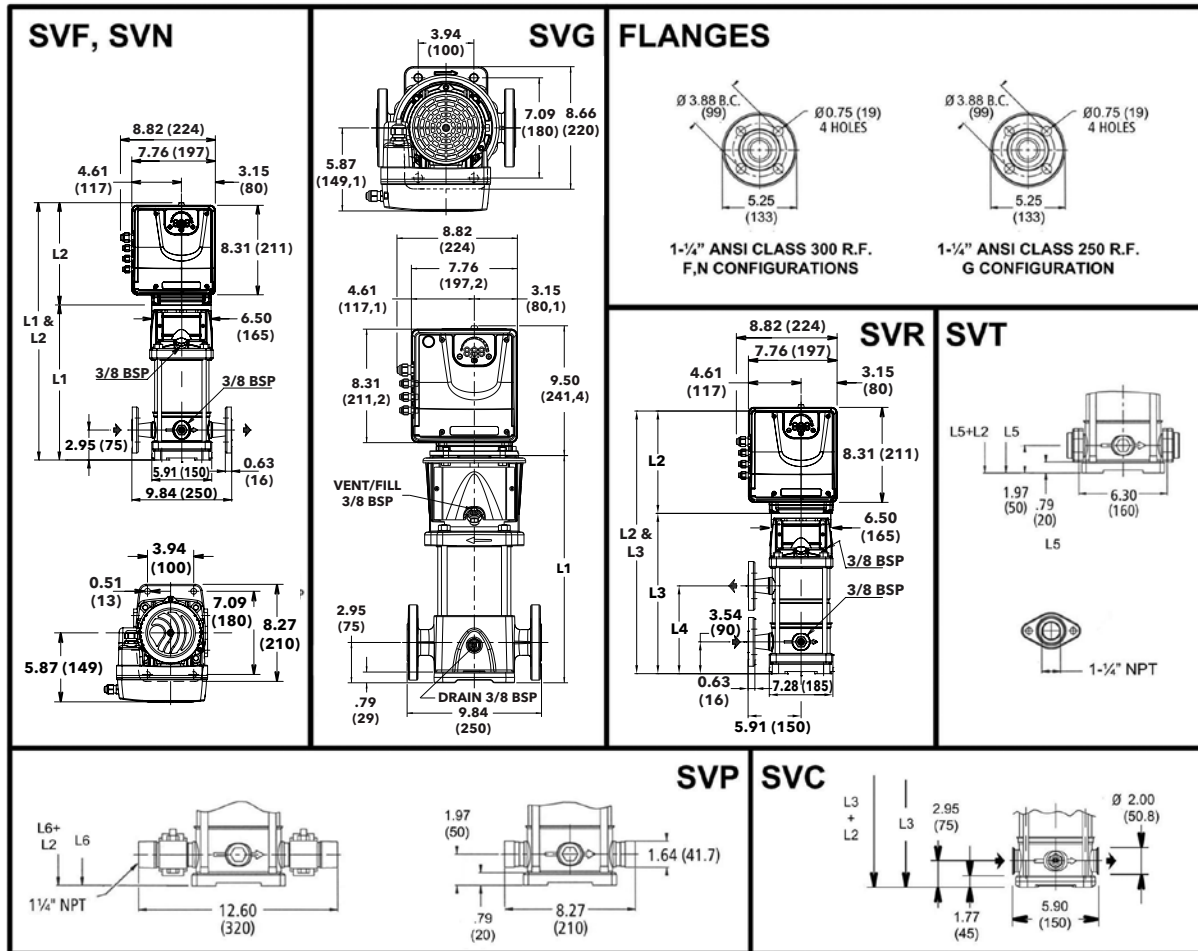

All dimensions are in inches (mm).

1SVE SERIES - 60 HZ, 3600 RPM TEFC ENCLOSURES

Pump Type Stages	Motor		Dimensions (in)								Weight (lbs)		
	P _N (HP)	Type 1 x 208-240 V	L1	L1 SVG	L2	L3	L4	L5	L6	D1 (max)	Pump Only	Motor	Pump/Motor
1SVE04	0.5	ESM90R/103 56C	14.08	14.28	9.53	-	-	13.10	13.10	5.20	27	16	43
1SVE06	0.75	ESM90R/105 56C	15.65	15.86	9.53	-	-	14.67	14.67	5.20	28	16	44
1SVE08	1	ESM90R/107 56C	17.23	17.43	9.53	17.24	8.94	16.25	16.25	5.20	30	16	46
1SVE12	1.5	ESM90R/111 56C	20.38	20.58	9.53	20.39	12.09	19.40	19.40	5.20	34	19	53
1SVE17	2	ESM90R/115 56C	24.32	24.52	9.53	24.32	16.02	23.34	23.34	5.20	38	19	57

3SVE SERIES - 60 HZ, 3600 RPM TEFC ENCLOSURES

Pump Type Stages	Motor		Dimensions (in)								Weight (lbs)		
	P _N (HP)	Type 1 x 208-240 V	L1	L1 SVG	L2	L3	L4	L5	L6	D1 (max)	Pump Only	Motor	Pump/Motor
3SVE02	0.5	ESM90R/103 56C	13.27	12.71	9.53	-	-	12.29	12.29	5.20	24	16	40
3SVE03	0.75	ESM90R/105 56C	13.29	13.49	9.53	-	-	12.31	12.31	5.20	25	16	41
3SVE04	1	ESM90R/107 56C	14.08	14.28	9.53	-	-	13.10	13.10	5.20	26	16	42
3SVE06	1.5	ESM90R/111 56C	15.65	15.86	9.53	-	-	14.67	14.67	5.20	27	19	46
3SVE09	2	ESM90R/115 56C	18.02	18.22	9.53	18.02	9.72	17.04	17.04	5.20	32	19	51

5SVE SERIES - 60 HZ, 3600 RPM TEFC ENCLOSURES

Pump Type Stages	Motor		Dimensions (in)								Weight (lbs)		
	P _N (HP)	Type 1 x 208-240 V	L1	L1 SVG	L2	L3	L4	L5	L6	D1 (max)	Pump Only	Motor	Pump/Motor
5SVE02	0.75	ESM90R/105 56C	13.86	13.10	9.53	-	-	12.88	12.88	5.20	25	16	41
5SVE03	1	ESM90R/107 56C	13.89	14.08	9.53	-	-	12.88	12.88	5.20	26	16	42
5SVE04	1.5	ESM90R/111 56C	14.87	15.07	9.53	-	-	13.86	13.86	5.20	28	19	47
5SVE06	2	ESM90R/115 56C	16.84	17.04	9.53	-	-	15.83	15.83	5.20	30	19	49

* Maximum value in specified range; PN = HP Rating; P1 = input power; I = input current.

1, 3, 5SVE SERIES - THREE PHASE VERSION DIMENSIONS AND WEIGHTS

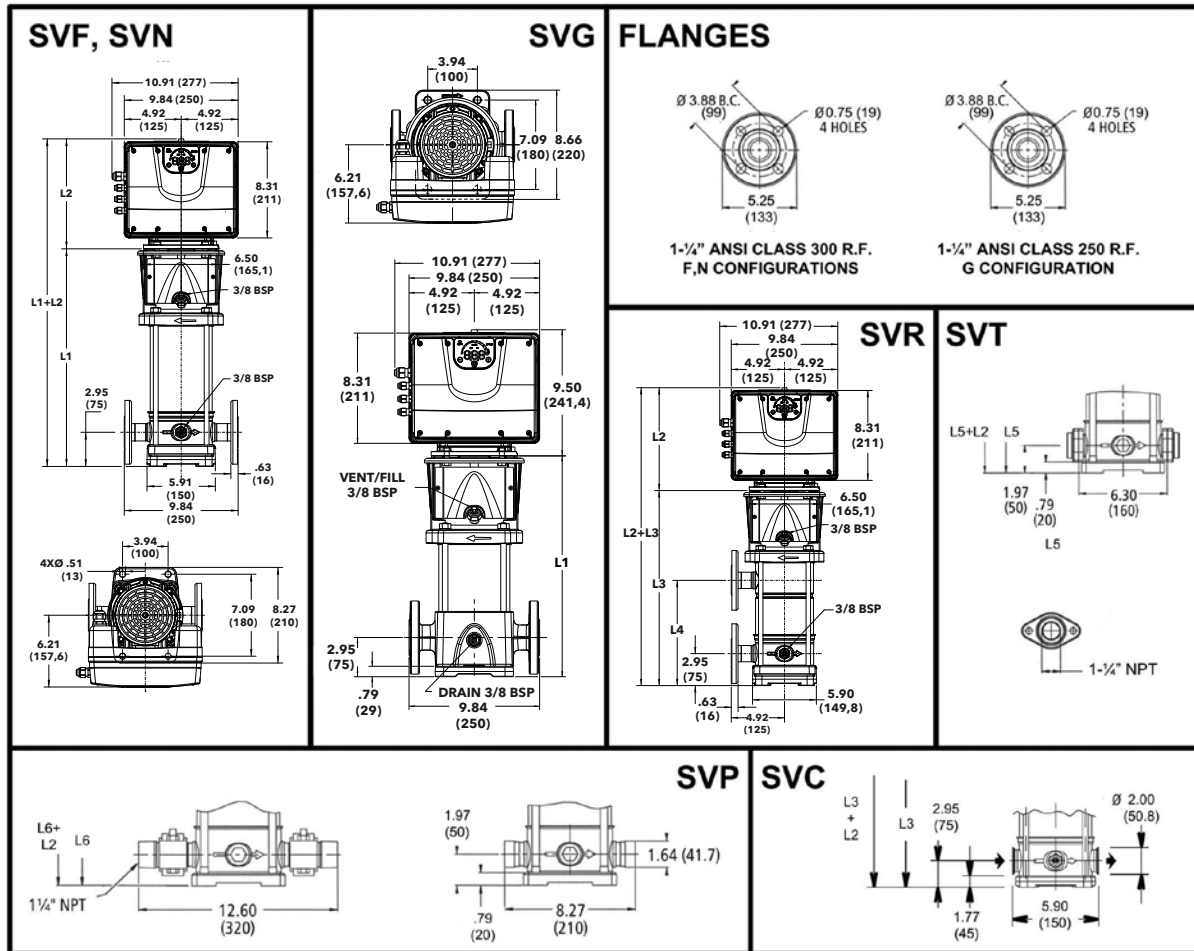

All dimensions are in inches (mm).

1SVE SERIES - 60 HZ, 3600 RPM TEFC ENCLOSURES

Pump Type Stages	Motor		Dimensions (in)								Weight (lbs)		
	P _N (HP)	Type 3 x 208-240V / 3 x 380 - 460V	L1	L1 SVG	L2	L3	L4	L5	L6	D1 (max)	Pump Only	Motor	Pump/Motor
1SVE04	0.5	ESM90R/303 56C	14.08	14.28	9.53	-	-	13.10	13.10	5.20	27	28	55
1SVE06	0.75	ESM90R/305 56C	15.65	15.86	9.53	-	-	14.67	14.67	5.20	28	28	56
1SVE08	1	ESM90R/307 56C	17.23	17.43	9.53	17.24	8.94	16.25	16.25	5.20	30	28	58
1SVE12	1.5	ESM90R/311 56C	20.38	20.58	9.53	20.39	12.09	19.40	19.40	5.20	34	32	66
1SVE17	2	ESM90R/315 56C	24.32	24.52	9.53	24.32	16.02	23.34	23.34	5.20	38	32	70
1SVE24	3	ESM90R/322 56C	29.83	30.03	9.53	29.84	21.54	-	28.85	5.20	46	35	81

3SVE SERIES - 60 HZ, 3600 RPM TEFC ENCLOSURES

Pump Type Stages	Motor		Dimensions (in)								Weight (lbs)		
	P _N (HP)	Type 3 x 208-240V / 3 x 380 - 460V	L1	L1 SVG	L2	L3	L4	L5	L6	D1 (max)	Pump Only	Motor	Pump/Motor
3SVE02	0.5	ESM90R/303 56C	13.27	12.71	9.53	-	-	12.29	12.29	5.20	24	28	52
3SVE03	0.75	ESM90R/305 56C	13.29	13.49	9.53	-	-	12.31	12.31	5.20	25	28	53
3SVE04	1	ESM90R/307 56C	14.08	14.28	9.53	-	-	13.10	13.10	5.20	26	28	54
3SVE06	1.5	ESM90R/311 56C	15.65	15.86	9.53	-	-	14.67	14.67	5.20	27	32	59
3SVE09	2	ESM90R/315 56C	18.02	18.22	9.53	18.02	9.72	17.04	17.04	5.20	32	32	64
3SVE13	3	ESM90R/322 56C	21.17	21.37	9.53	21.17	12.87	20.19	20.19	5.20	36	35	71

5SVE SERIES - 60 HZ, 3600 RPM TEFC ENCLOSURES

Pump Type Stages	Motor		Dimensions (in)								Weight (lbs)		
	P _N (HP)	Type 3 x 208-240V / 3 x 380 - 460V	L1	L1 SVG	L2	L3	L4	L5	L6	D1 (max)	Pump Only	Motor	Pump/Motor
5SVE02	0.75	ESM90R/305 56C	13.86	13.10	9.53	-	-	12.88	12.88	5.20	25	28	53
5SVE03	1	ESM90R/307 56C	13.89	14.08	9.53	-	-	12.88	12.88	5.20	26	28	54
5SVE04	1.5	ESM90R/311 56C	14.87	15.07	9.53	-	-	13.86	13.86	5.20	28	32	60
5SVE06	2	ESM90R/315 56C	16.84	17.04	9.53	-	-	15.83	15.83	5.20	30	32	62
5SVE09	3	ESM90R/322 56C	19.79	19.99	9.53	19.77	11.50	18.78	18.78	5.20	33	35	68

* Maximum value in specified range; PN = HP Rating; P1 = input power; I = input current.

1SVE SERIES OPERATING CHARACTERISTICS

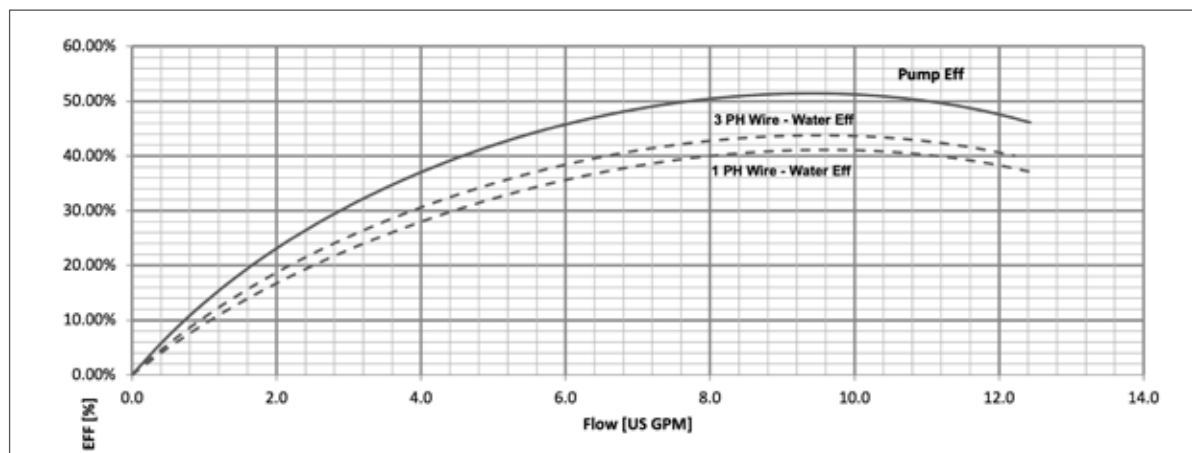
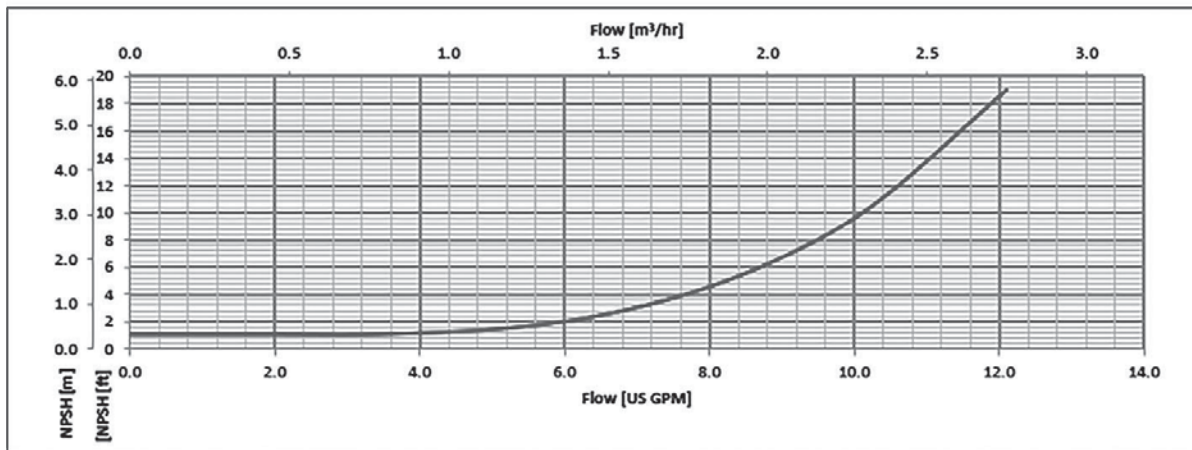
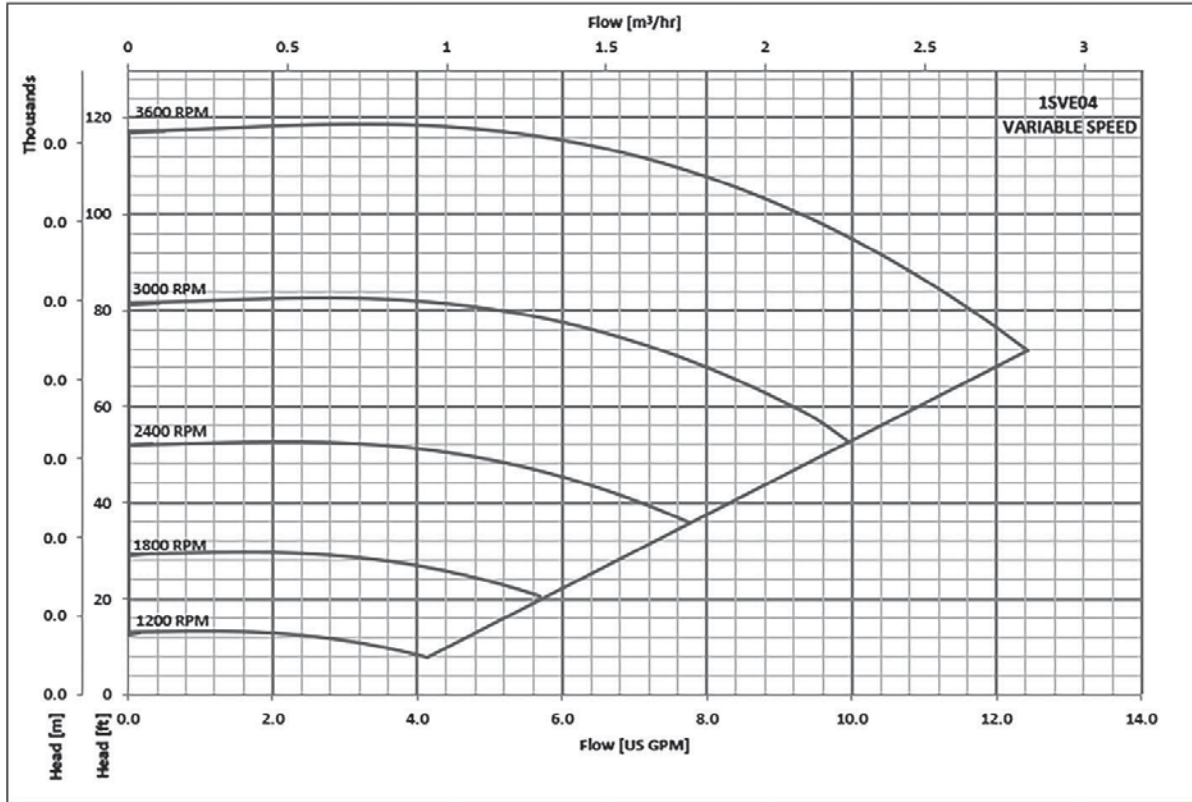

The performances are valid for liquid with density $\rho = 1.0 \text{ Kg/dm}^3$ and kinematic viscosity $\nu = 1 \text{ mm}^2/\text{sec}$.

1SVE SERIES OPERATING CHARACTERISTICS

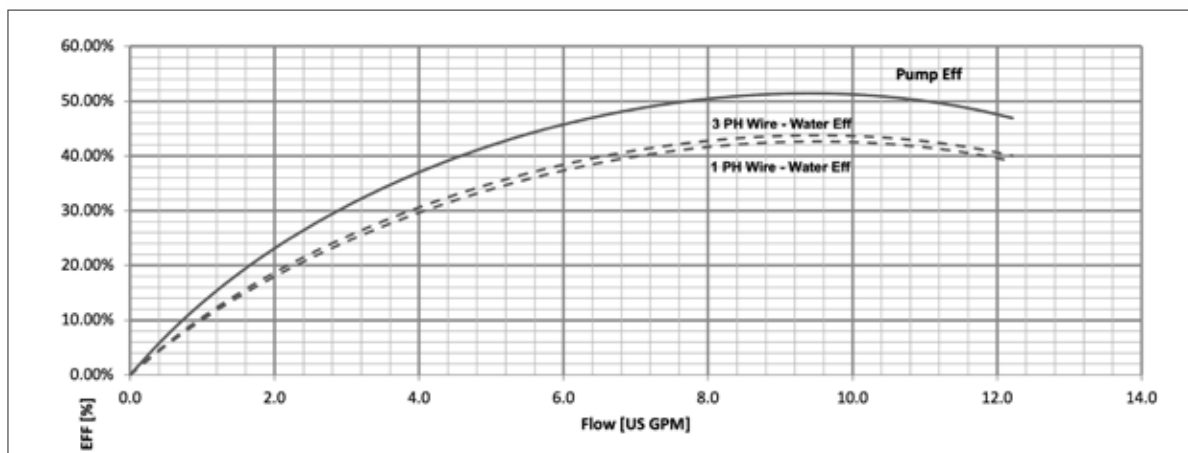
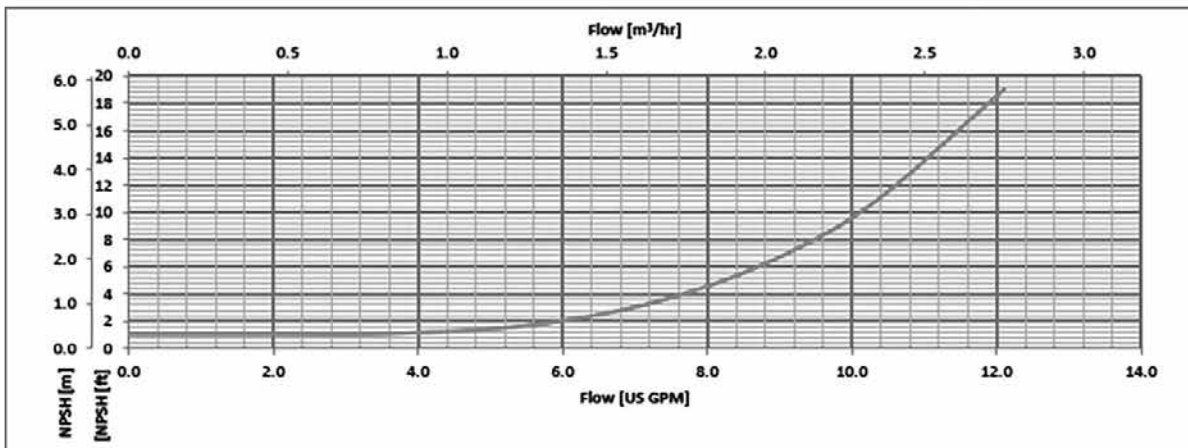
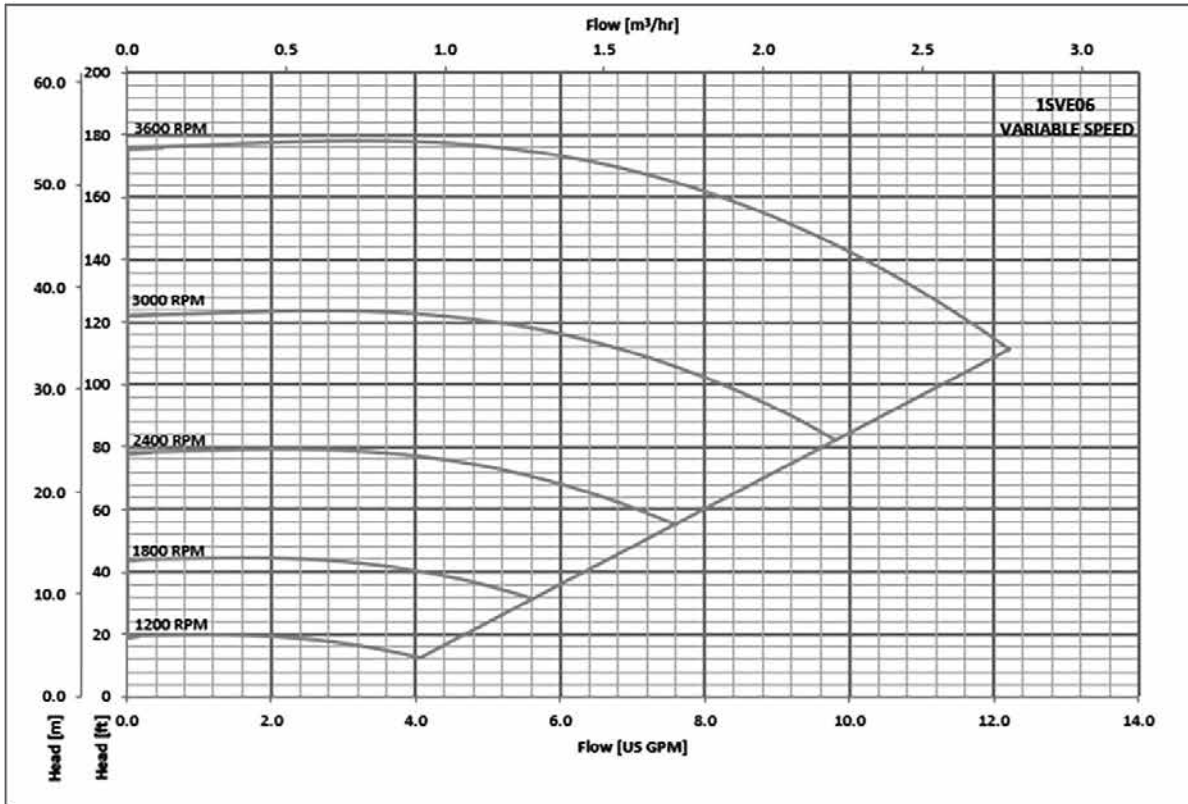

The performances are valid for liquid with density $\rho = 1.0 \text{ Kg/dm}^3$ and kinematic viscosity $\nu = 1 \text{ mm}^2/\text{sec}$.

1SVE SERIES OPERATING CHARACTERISTICS

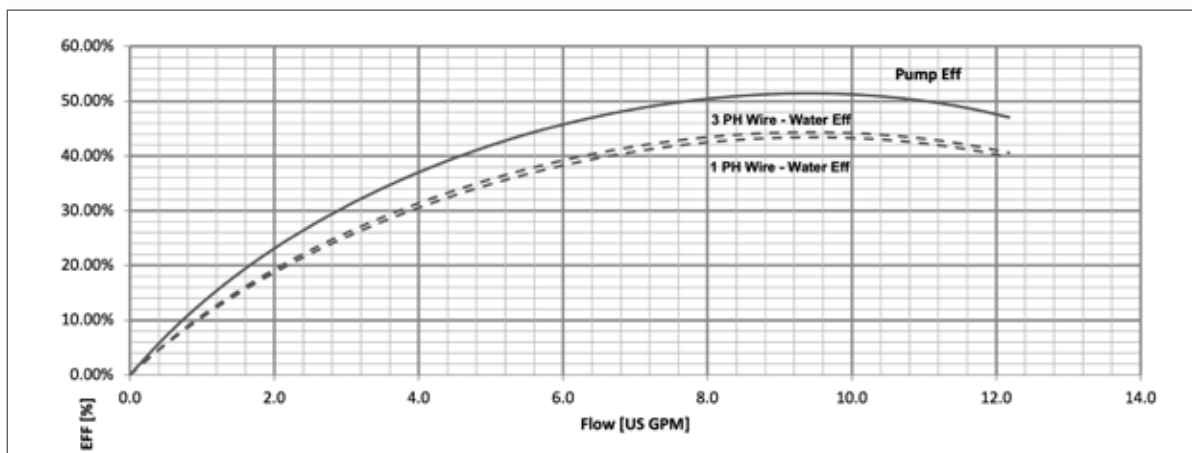
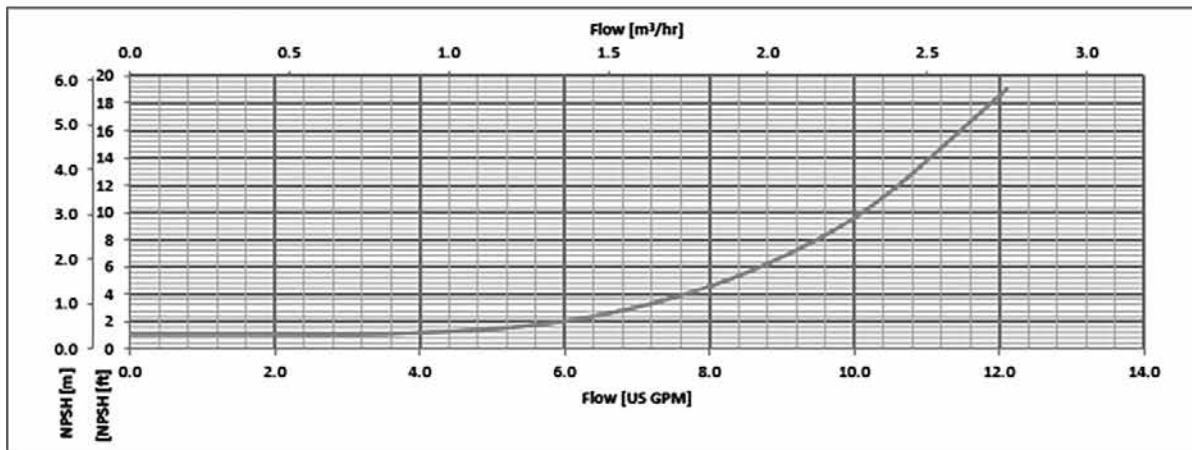
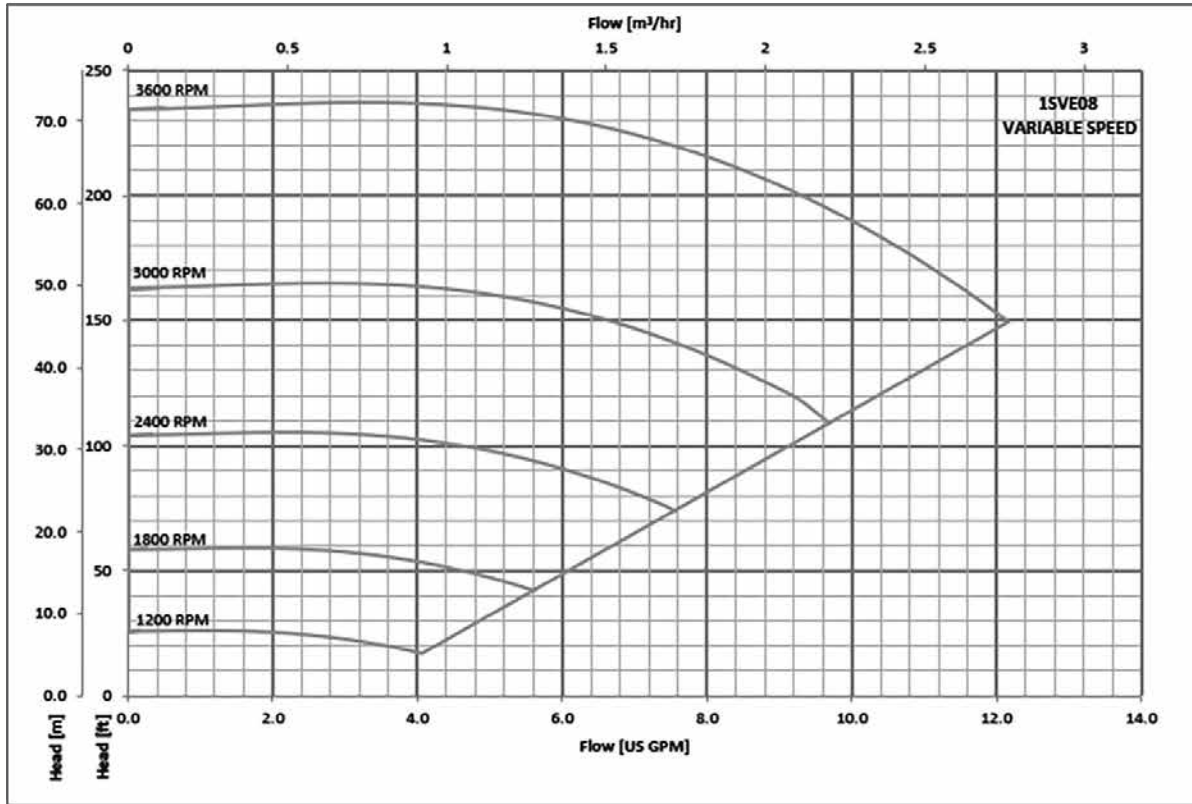

The performances are valid for liquid with density $\rho = 1.0 \text{ Kg/dm}^3$ and kinematic viscosity $\nu = 1 \text{ mm}^2/\text{sec}$.

1SVE SERIES OPERATING CHARACTERISTICS

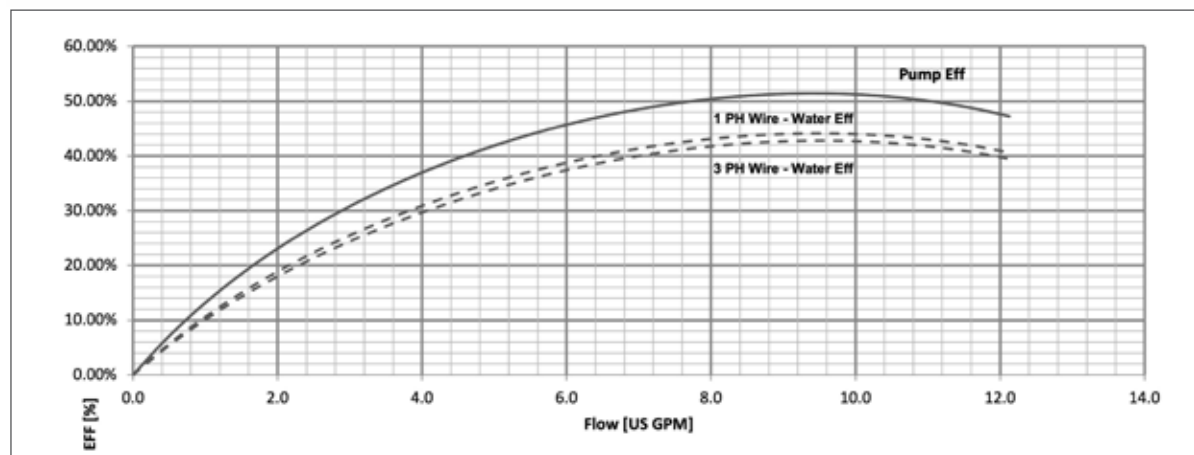
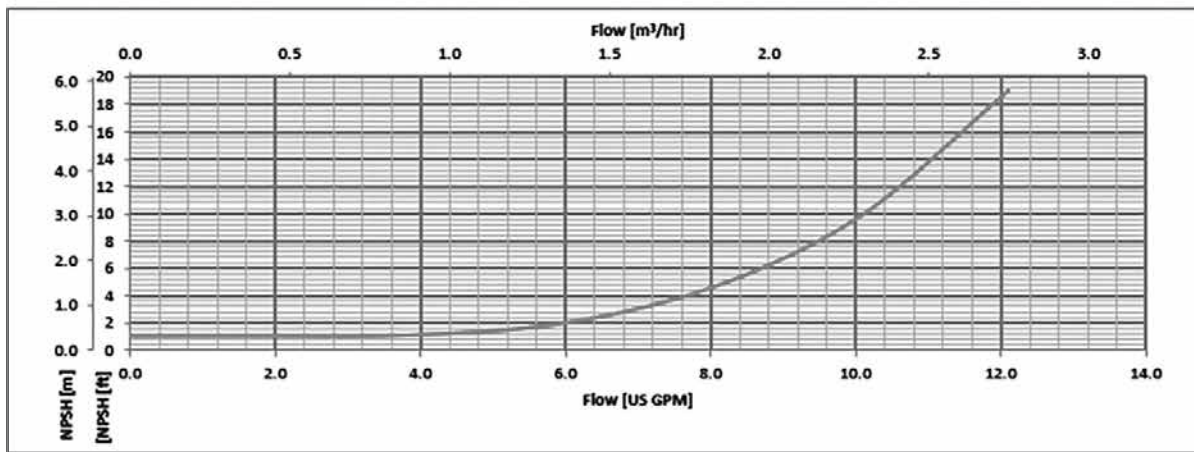
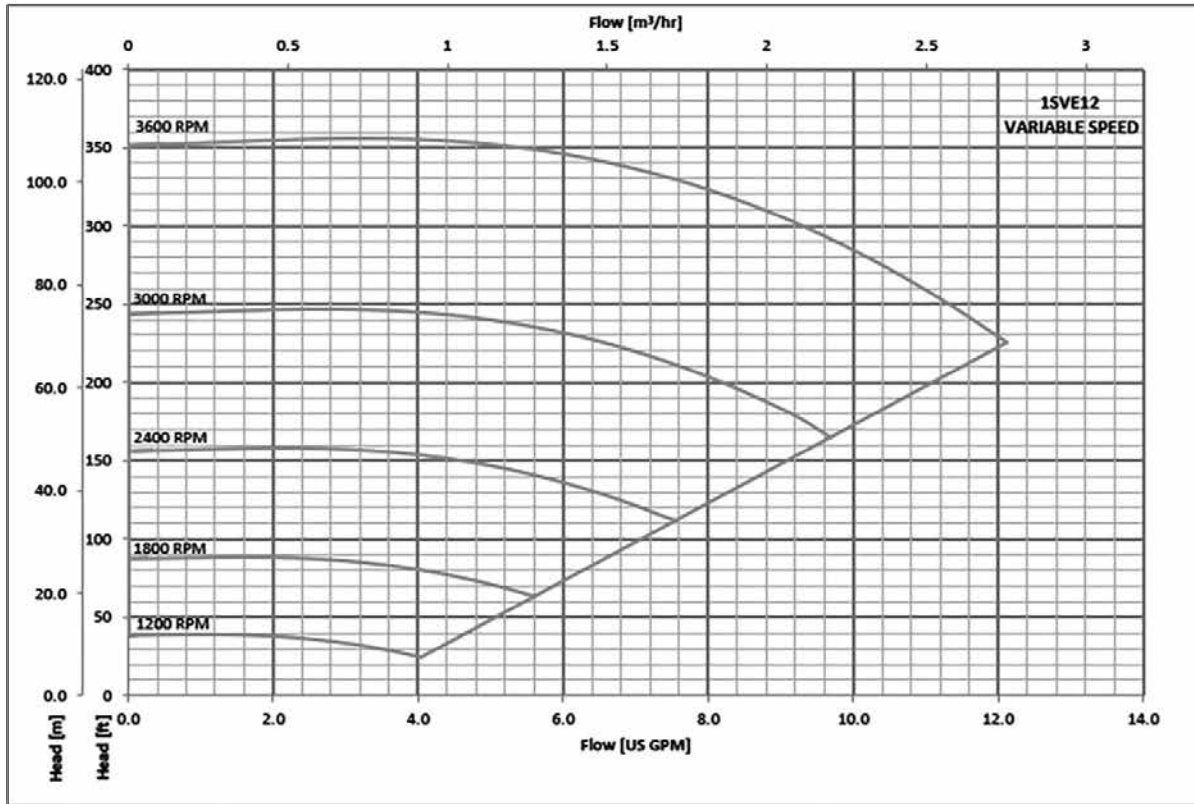

The performances are valid for liquid with density $\rho = 1.0 \text{ Kg/dm}^3$ and kinematic viscosity $\nu = 1 \text{ mm}^2/\text{sec}$.

1SVE SERIES OPERATING CHARACTERISTICS

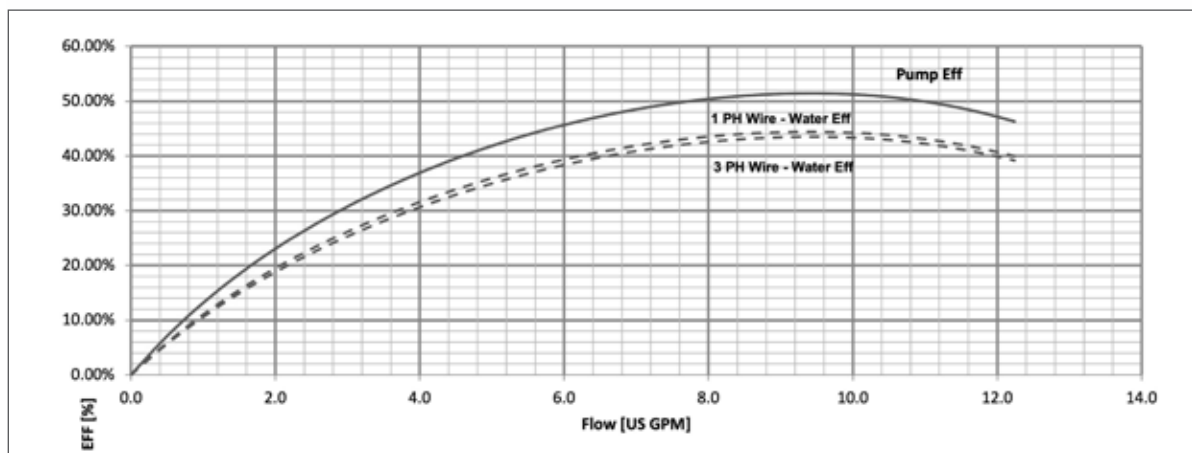
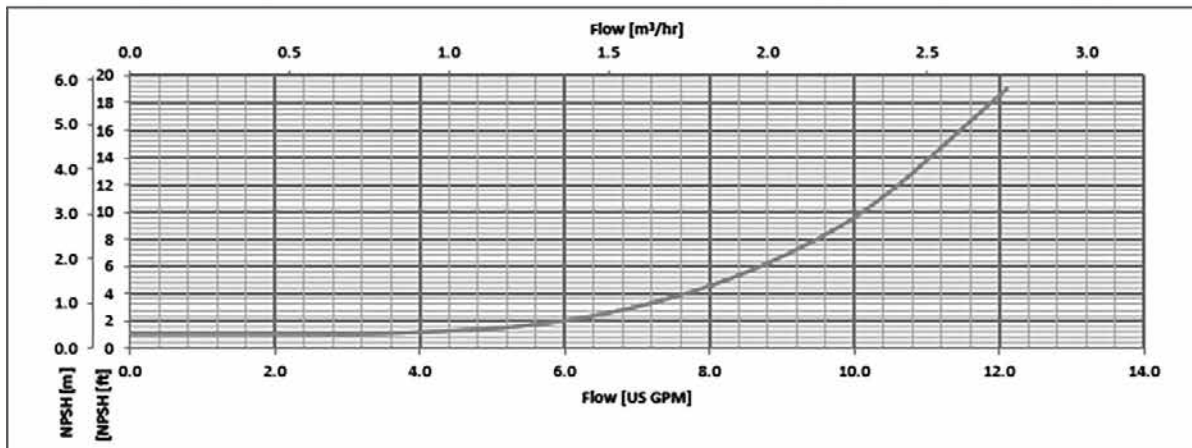
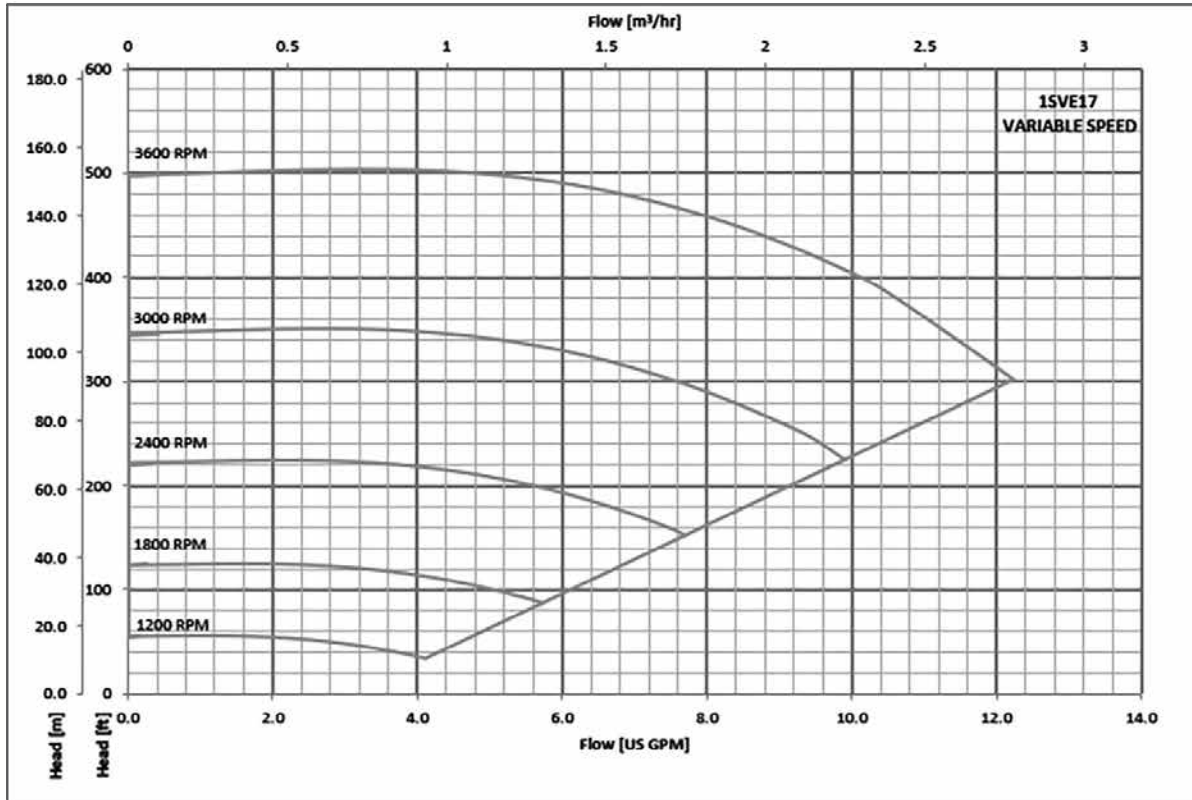

The performances are valid for liquid with density $\rho = 1.0 \text{ Kg/dm}^3$ and kinematic viscosity $\nu = 1 \text{ mm}^2/\text{sec}$.

3SVE SERIES OPERATING CHARACTERISTICS

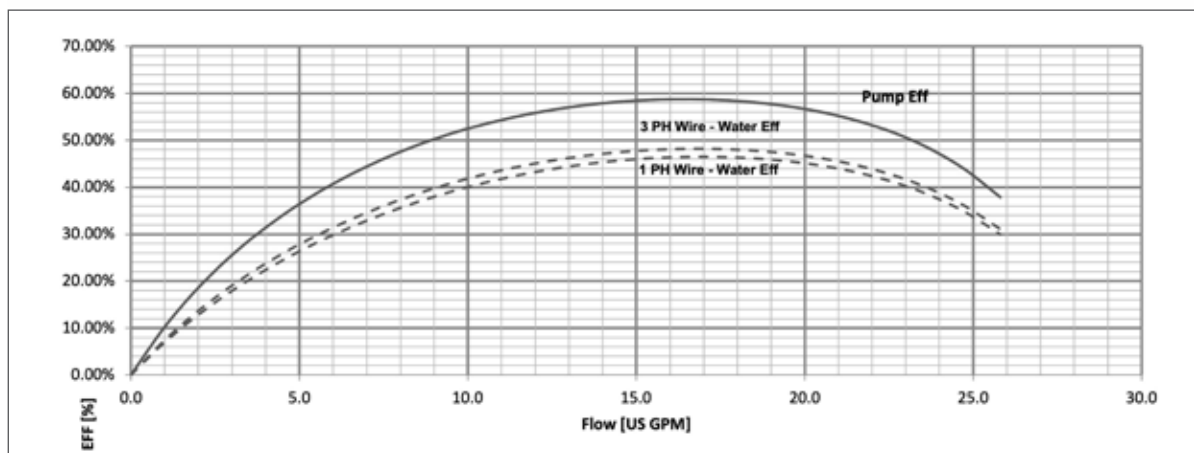
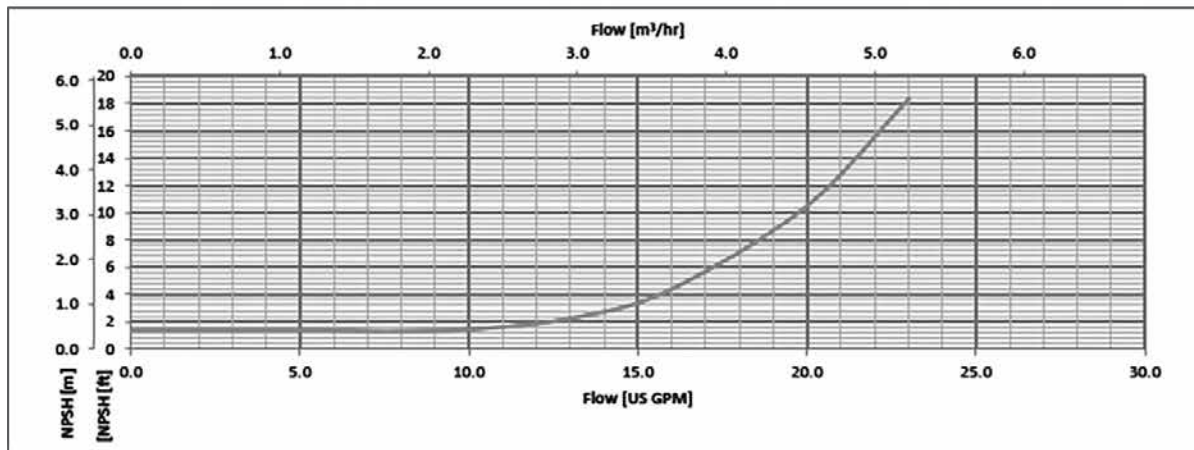
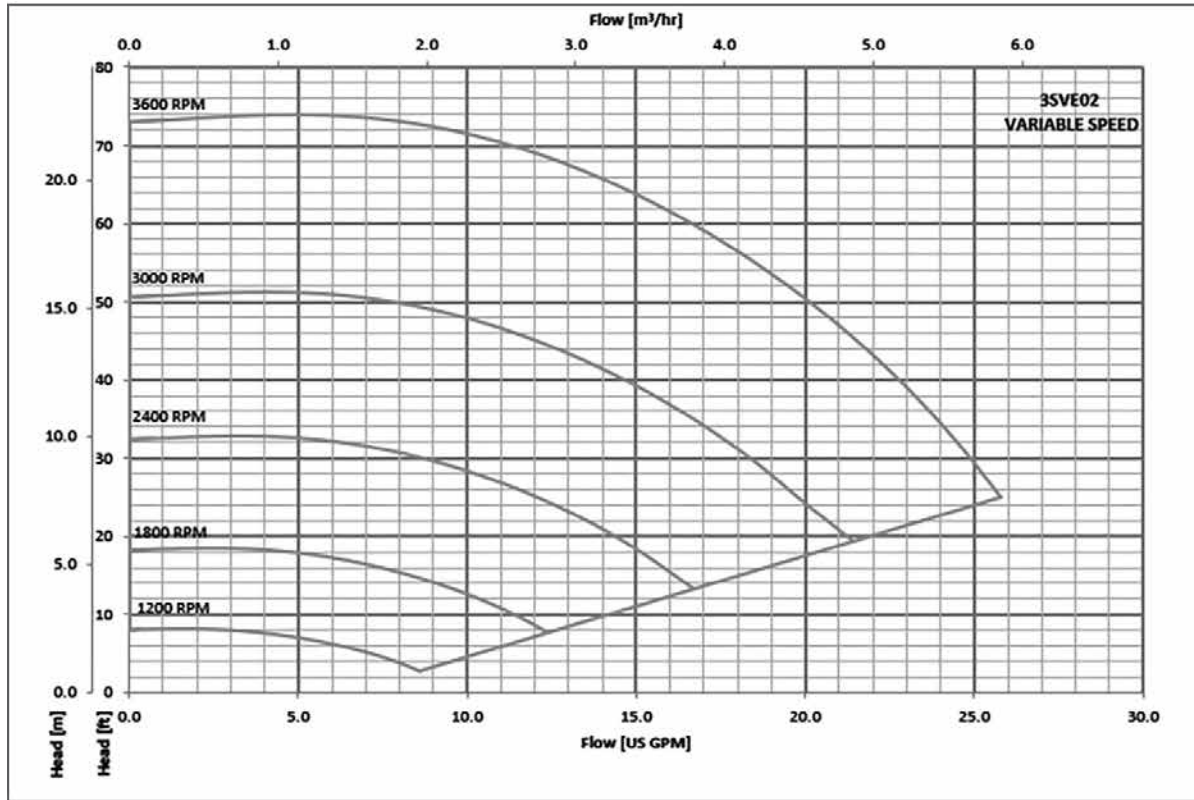

The performances are valid for liquid with density $\rho = 1.0 \text{ Kg/dm}^3$ and kinematic viscosity $\nu = 1 \text{ mm}^2/\text{sec}$.

3SVE SERIES OPERATING CHARACTERISTICS

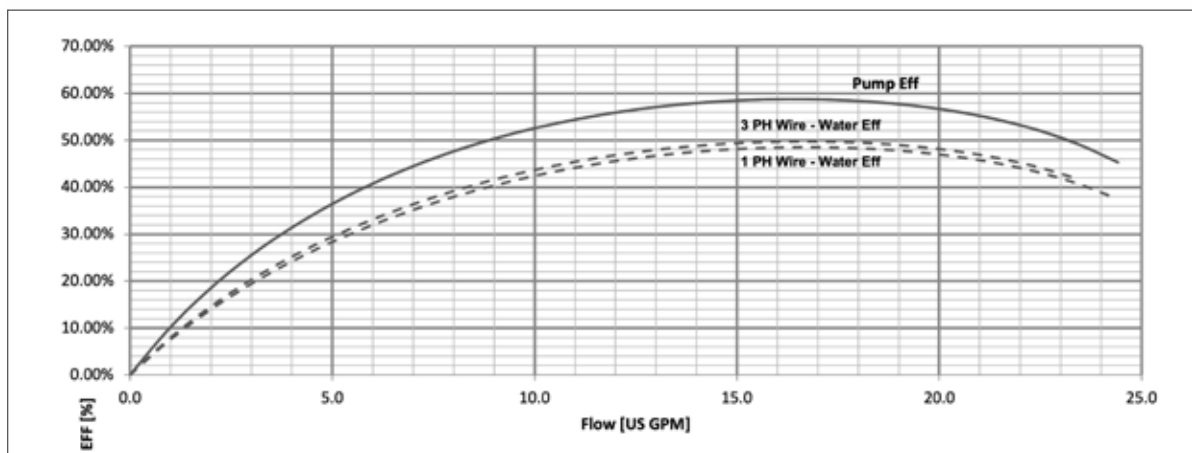
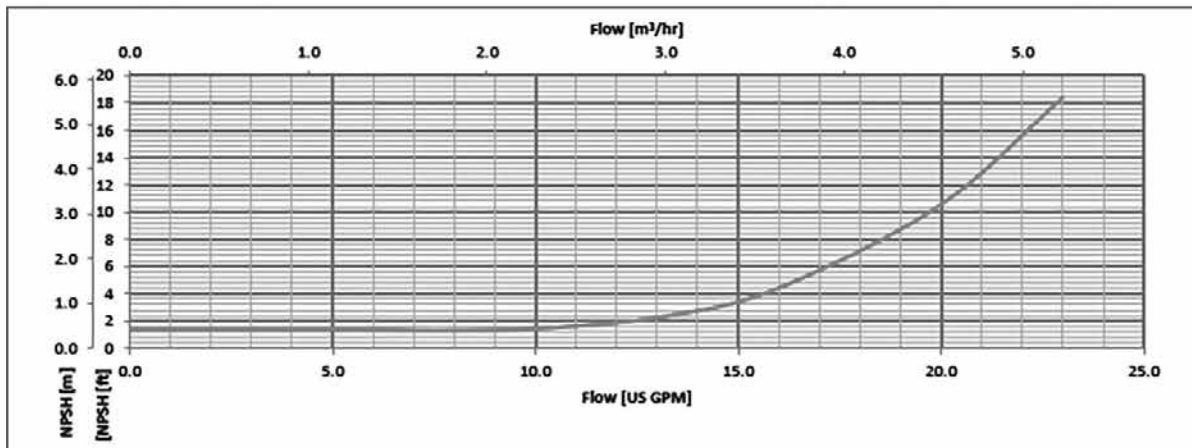
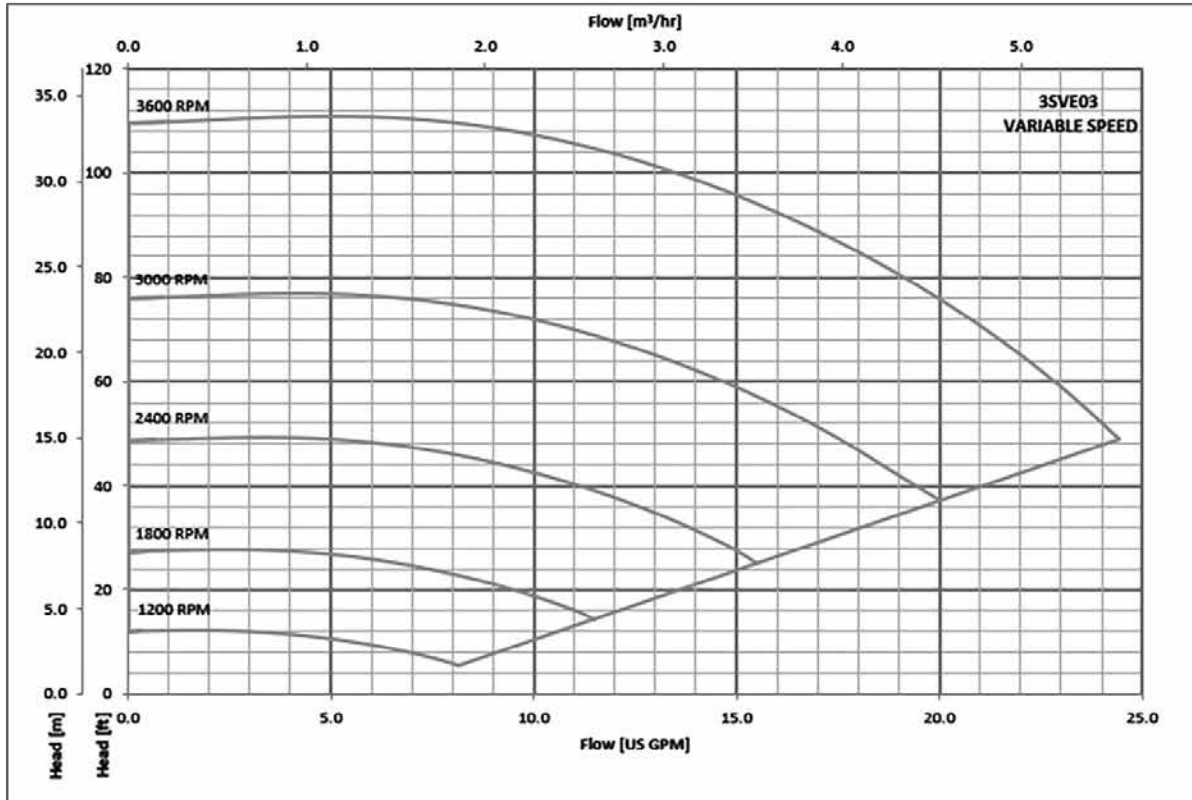

The performances are valid for liquid with density $\rho = 1.0 \text{ Kg/dm}^3$ and kinematic viscosity $\nu = 1 \text{ mm}^2/\text{sec}$.

3SVE SERIES OPERATING CHARACTERISTICS

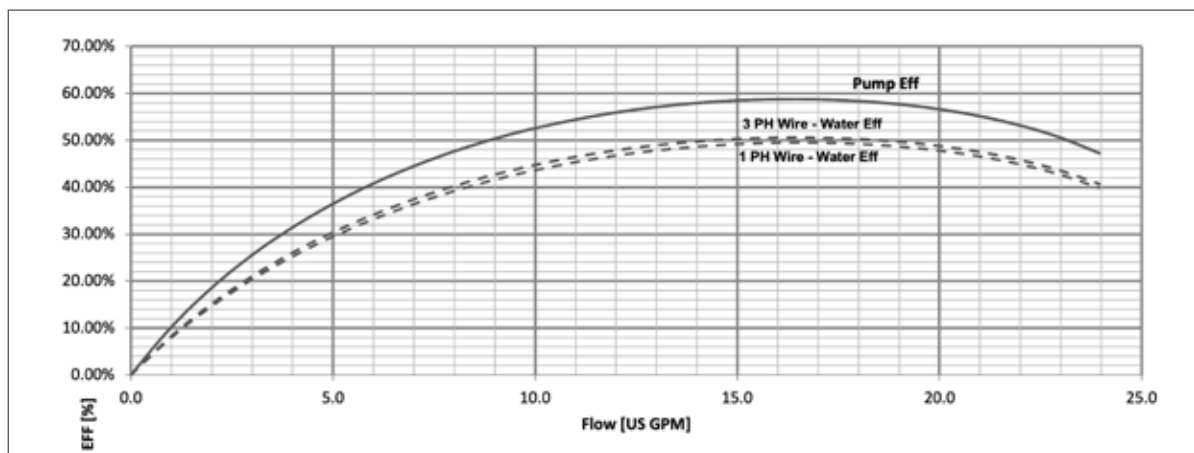
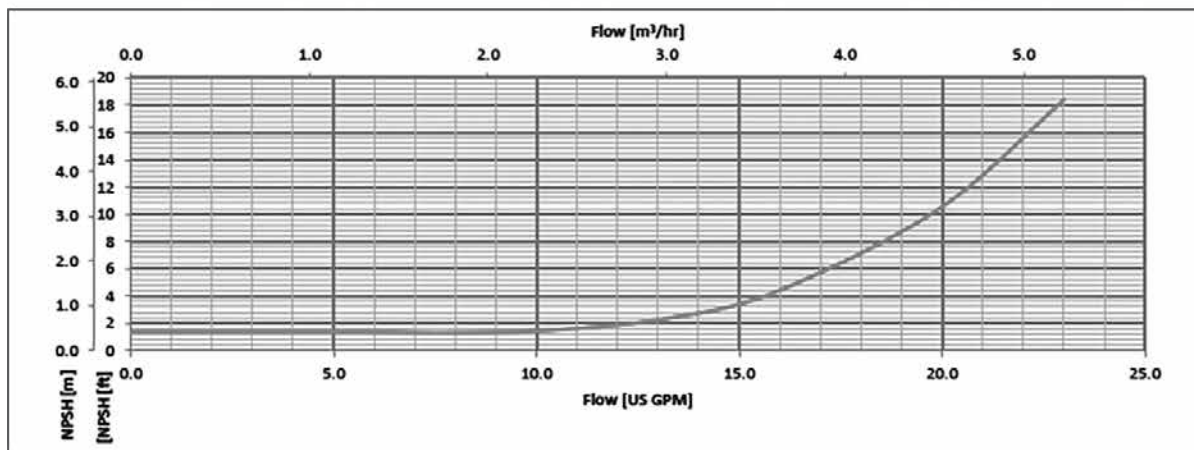
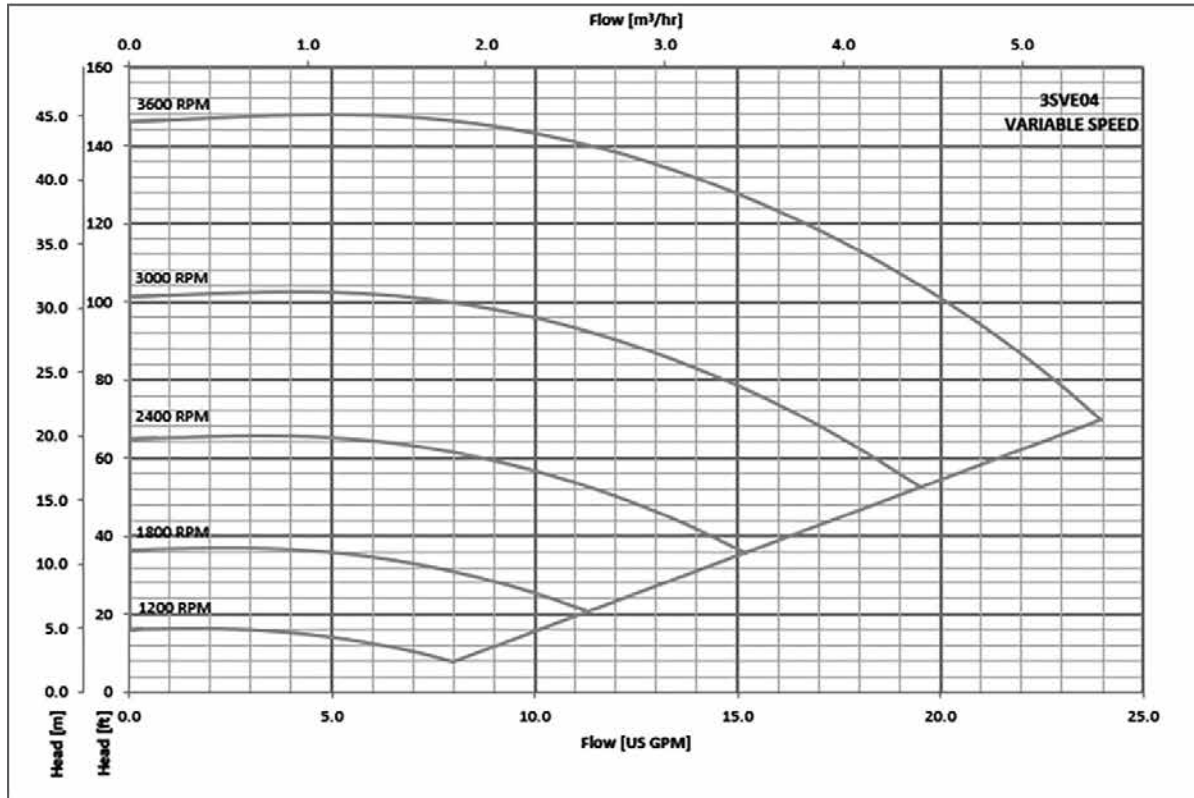

The performances are valid for liquid with density $\rho = 1.0 \text{ Kg/dm}^3$ and kinematic viscosity $\nu = 1 \text{ mm}^2/\text{sec}$.

3SVE SERIES OPERATING CHARACTERISTICS

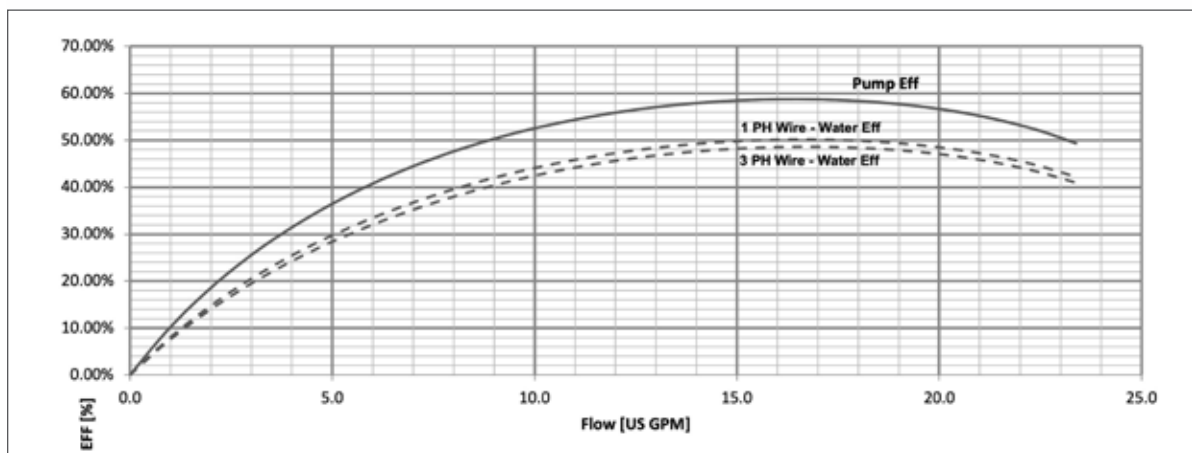
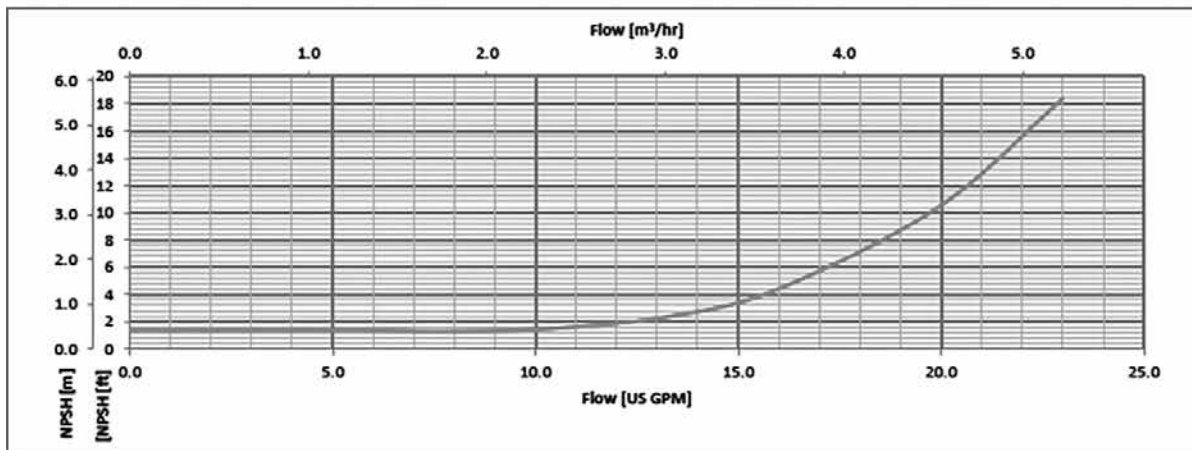
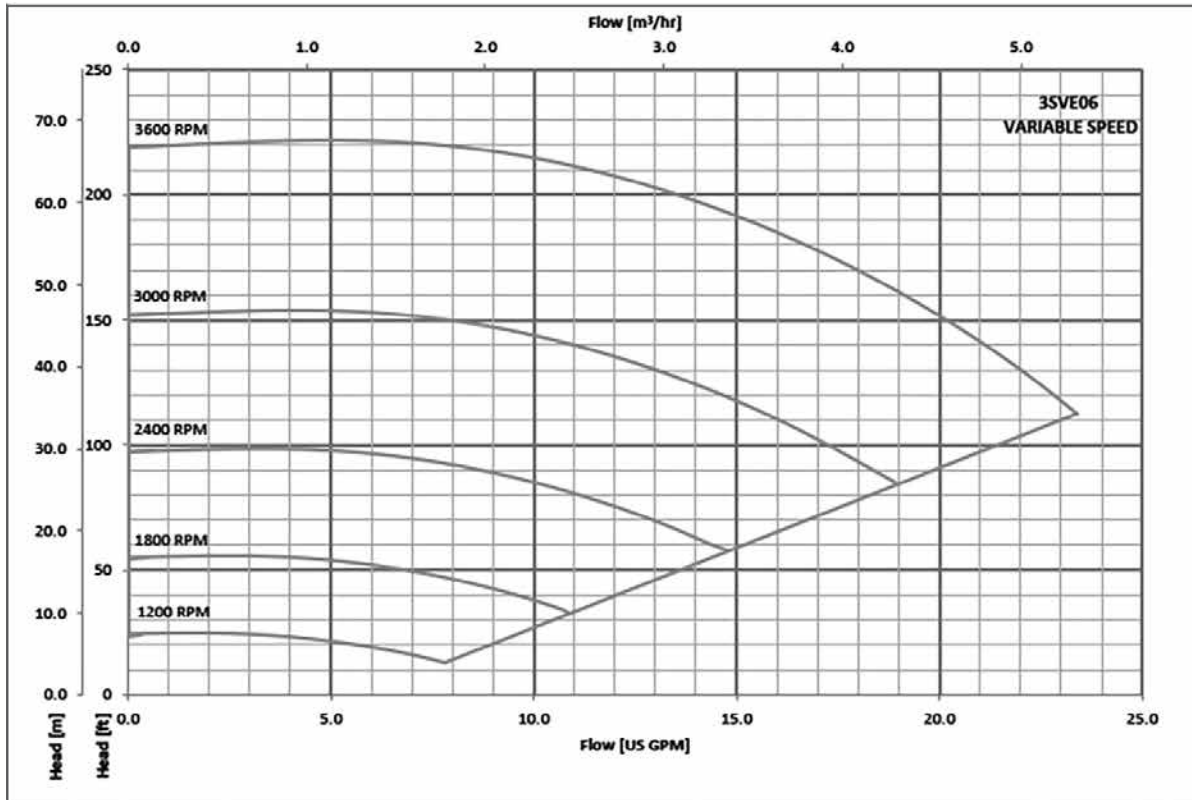

The performances are valid for liquid with density $\rho = 1.0 \text{ Kg/dm}^3$ and kinematic viscosity $\nu = 1 \text{ mm}^2/\text{sec}$.

3SVE SERIES OPERATING CHARACTERISTICS

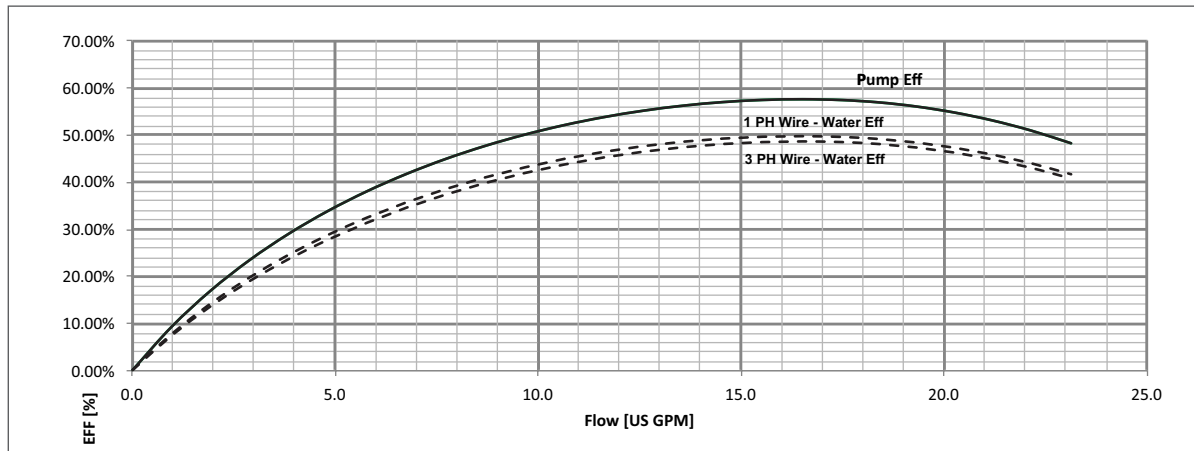
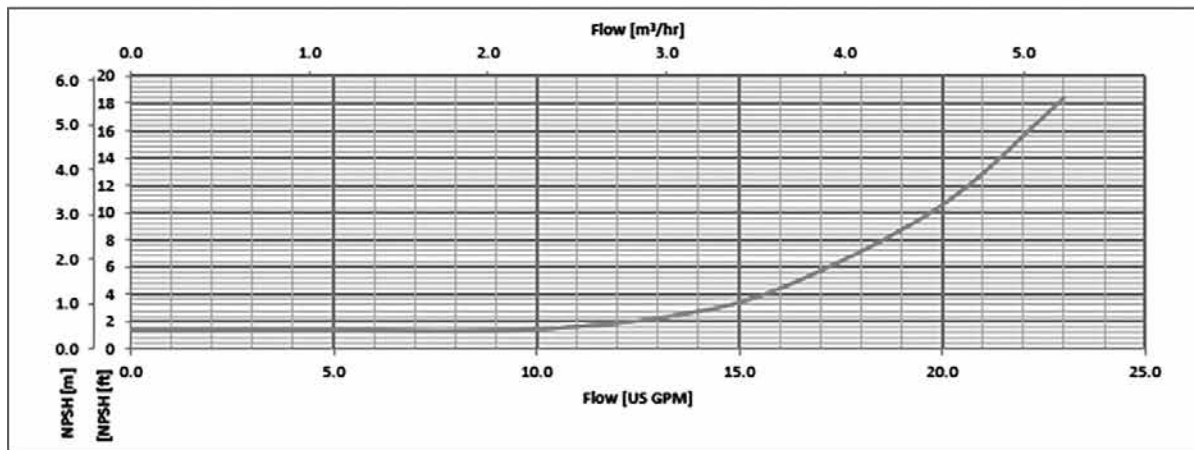
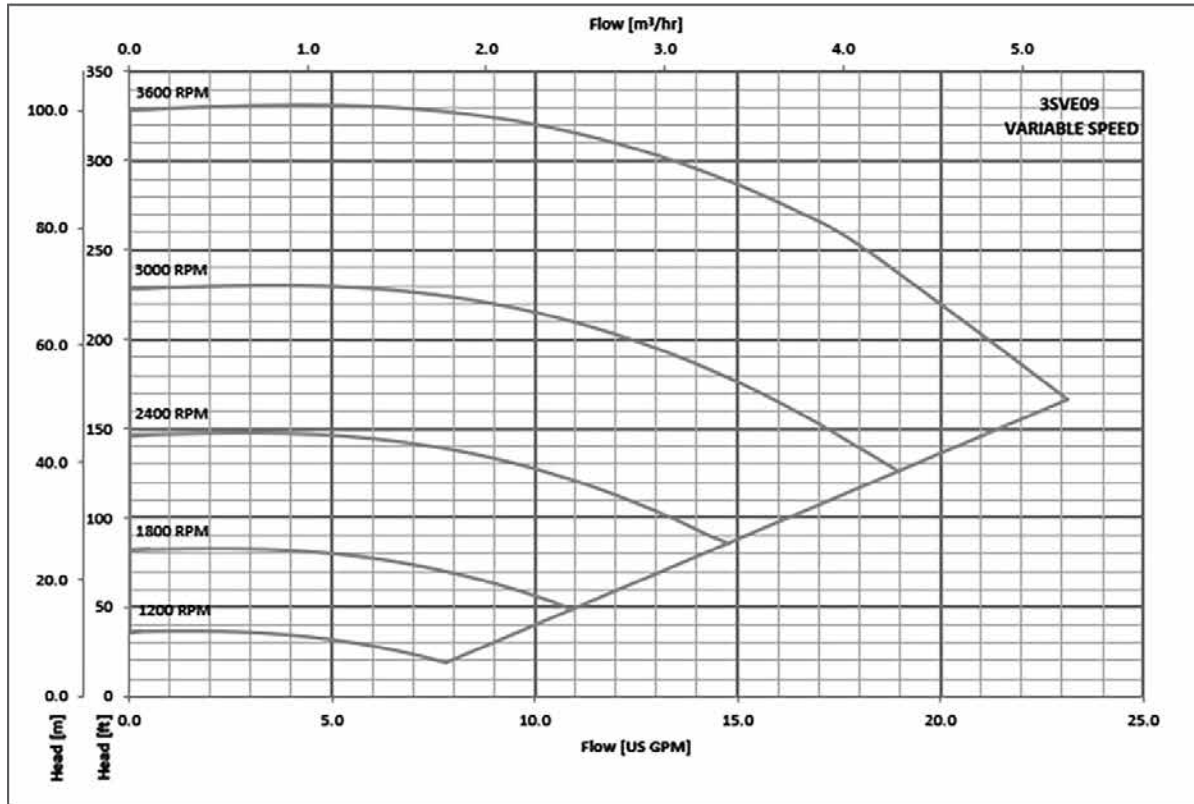

The performances are valid for liquid with density $\rho = 1.0 \text{ Kg/dm}^3$ and kinematic viscosity $\nu = 1 \text{ mm}^2/\text{sec}$.

3SVE SERIES OPERATING CHARACTERISTICS

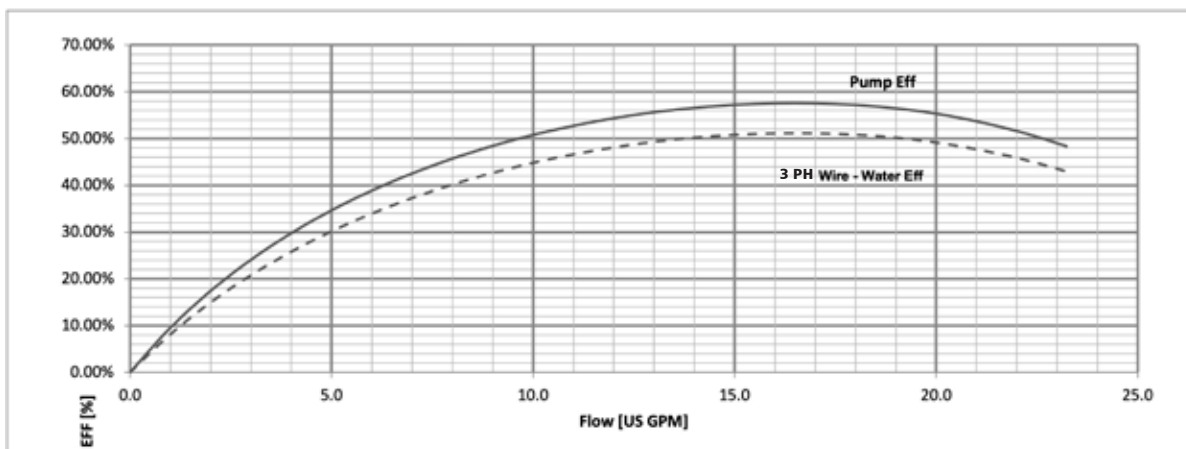
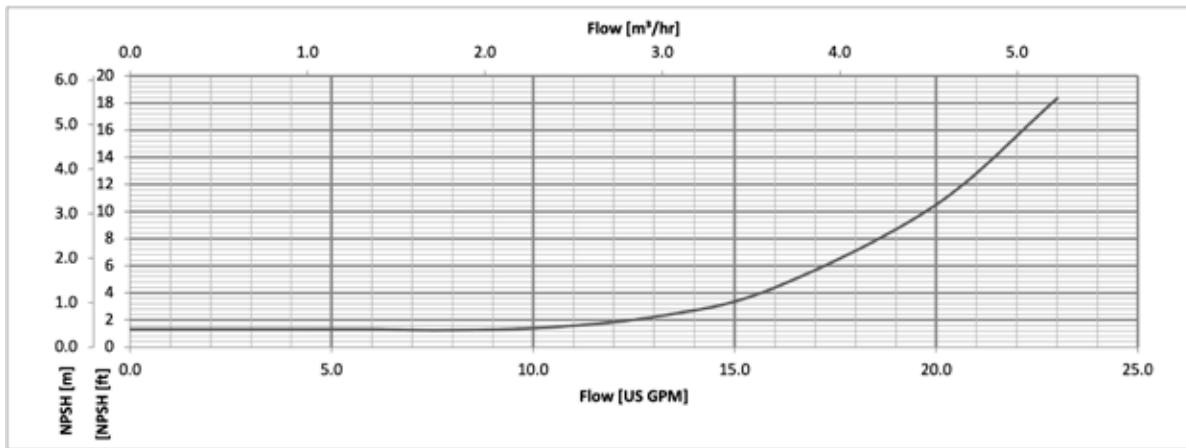
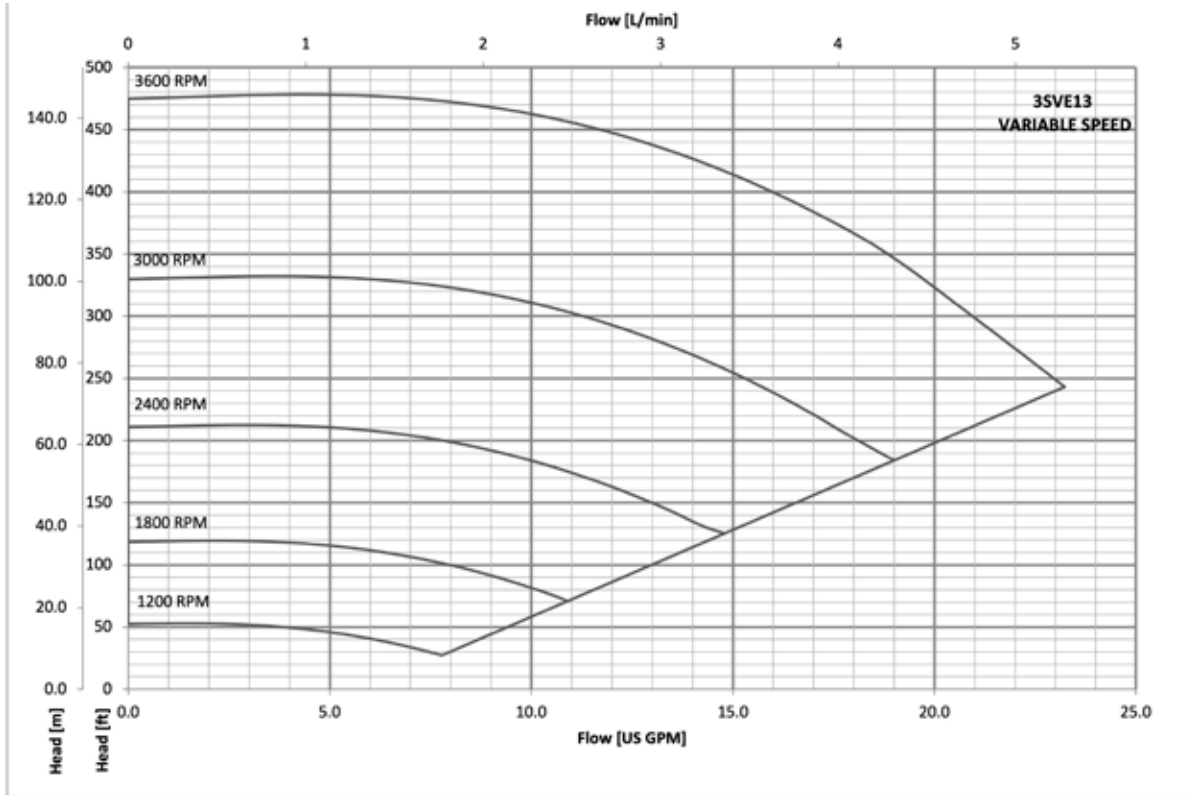

5SVE SERIES OPERATING CHARACTERISTICS

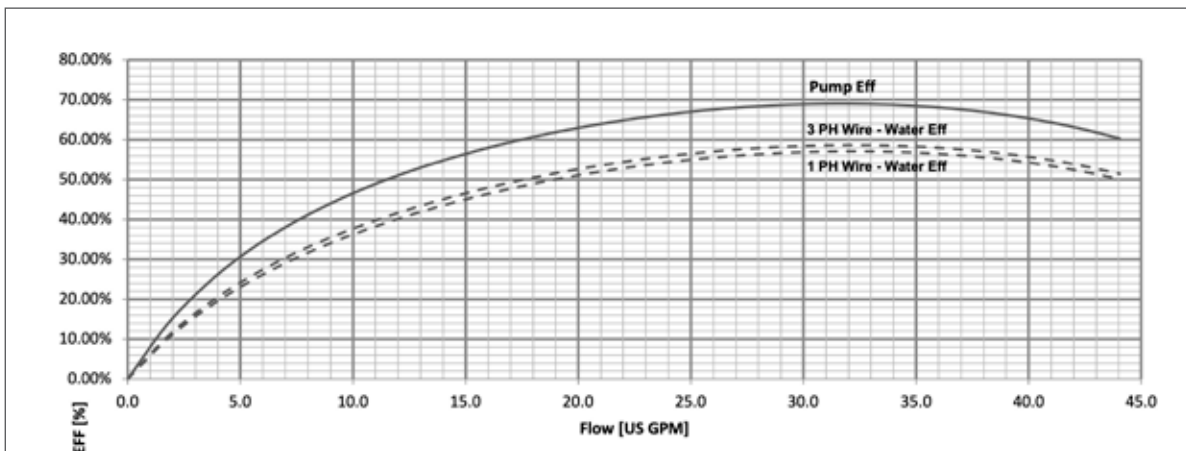
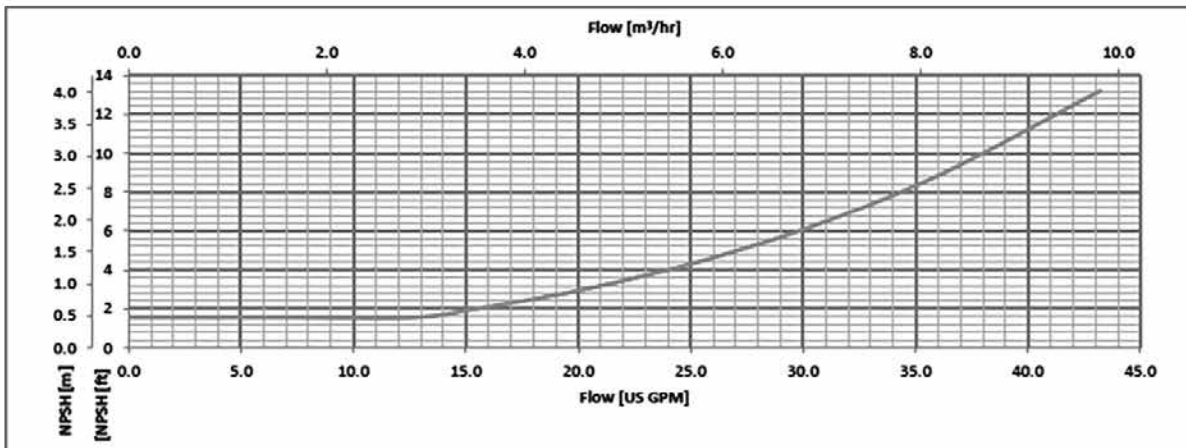
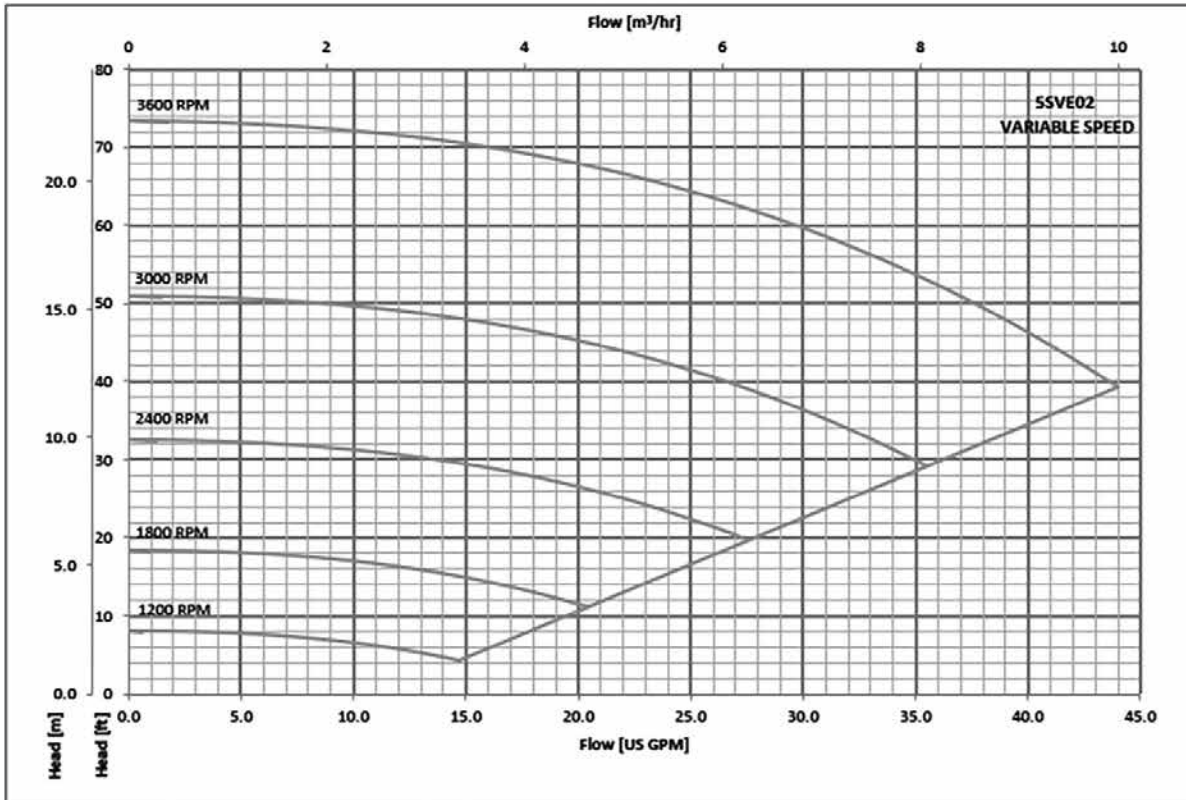

The performances are valid for liquid with density $\rho = 1.0 \text{ Kg/dm}^3$ and kinematic viscosity $\nu = 1 \text{ mm}^2/\text{sec}$.

5SVE SERIES OPERATING CHARACTERISTICS

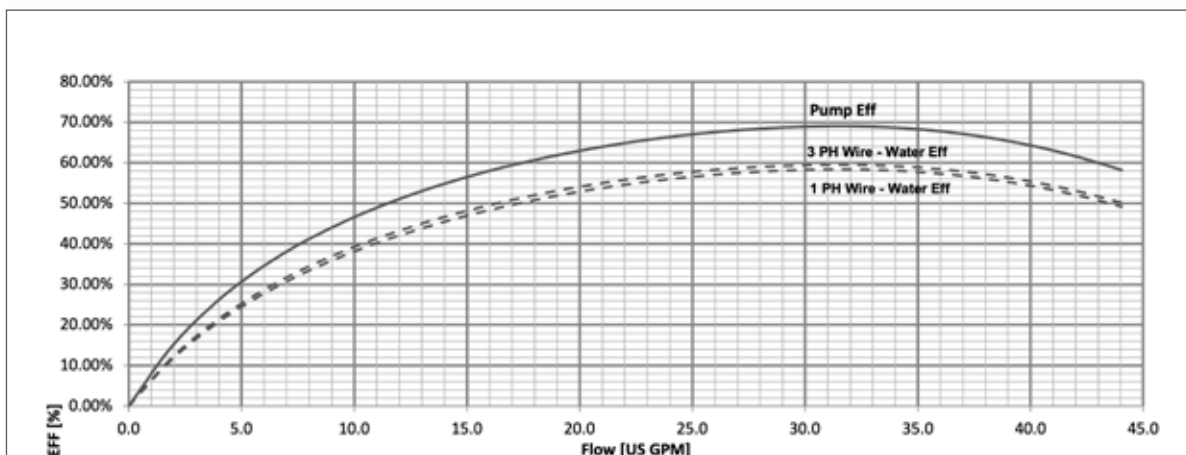
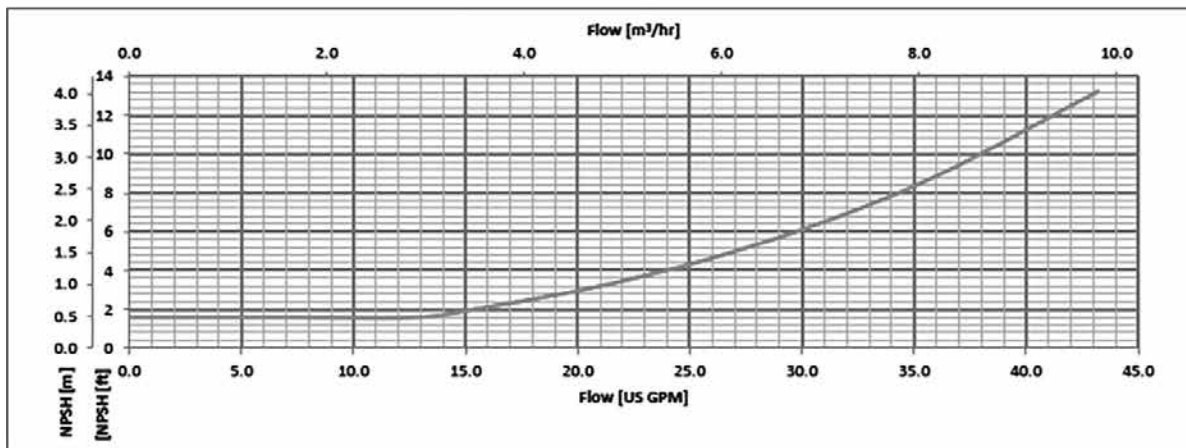
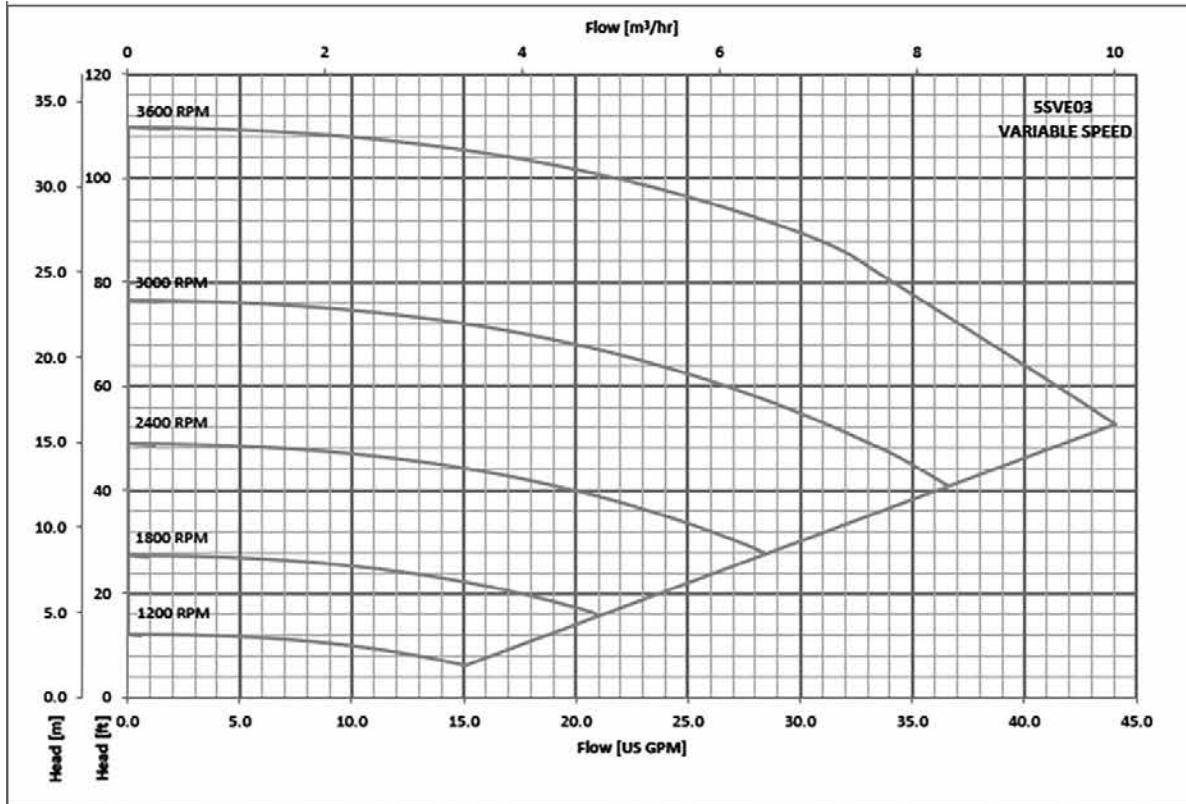

The performances are valid for liquid with density $\rho = 1.0 \text{ Kg/dm}^3$ and kinematic viscosity $\nu = 1 \text{ mm}^2/\text{sec}$.

5SVE SERIES OPERATING CHARACTERISTICS

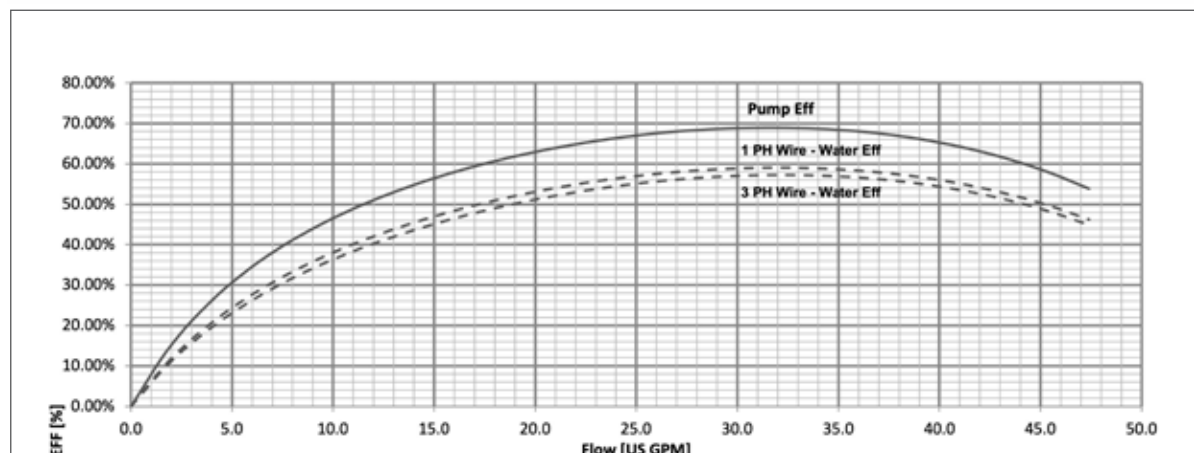
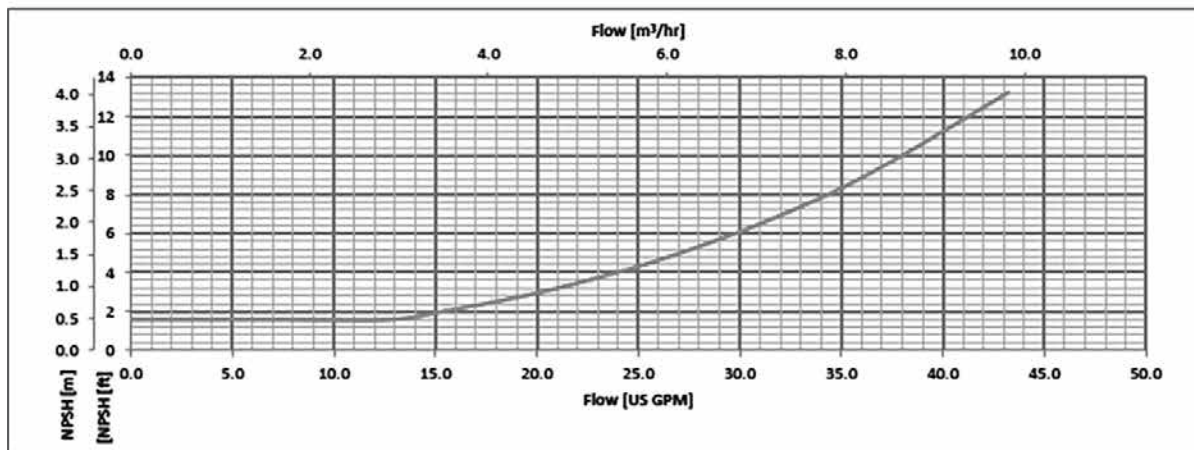
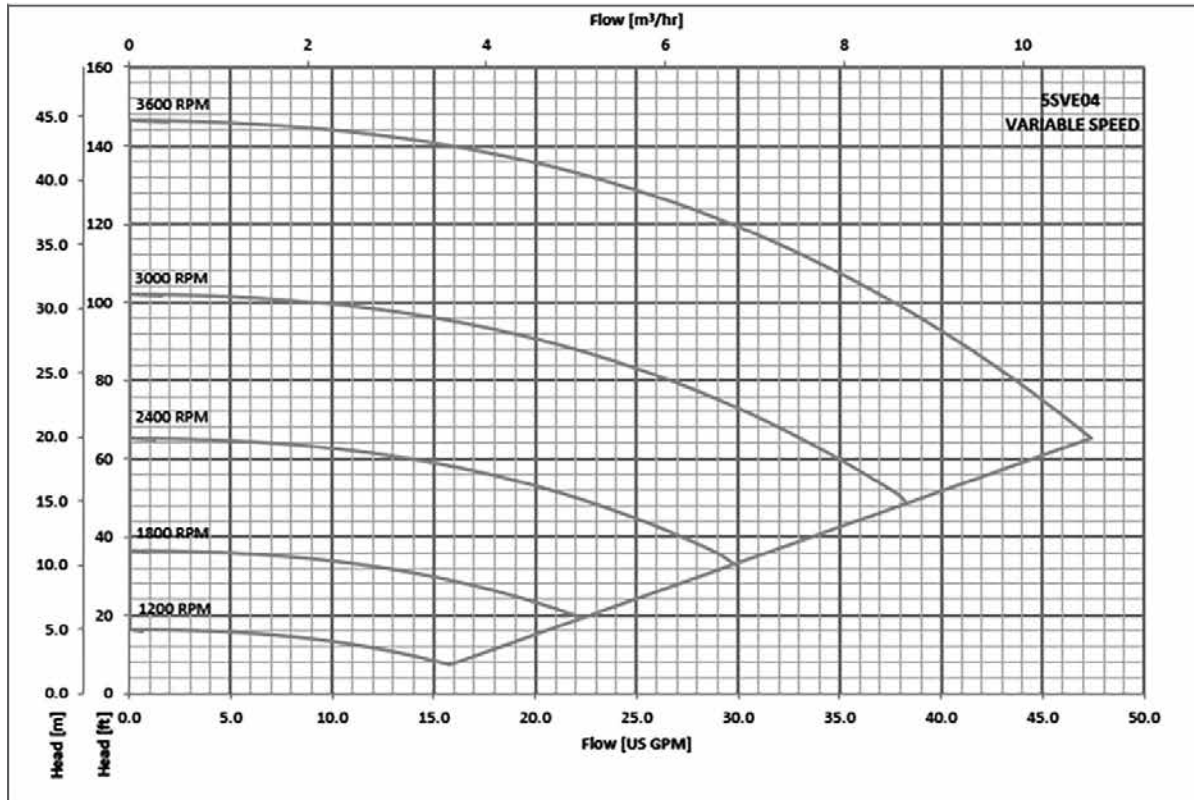

The performances are valid for liquid with density $\rho = 1.0 \text{ Kg/dm}^3$ and kinematic viscosity $\nu = 1 \text{ mm}^2/\text{sec}$.

5SVE SERIES OPERATING CHARACTERISTICS

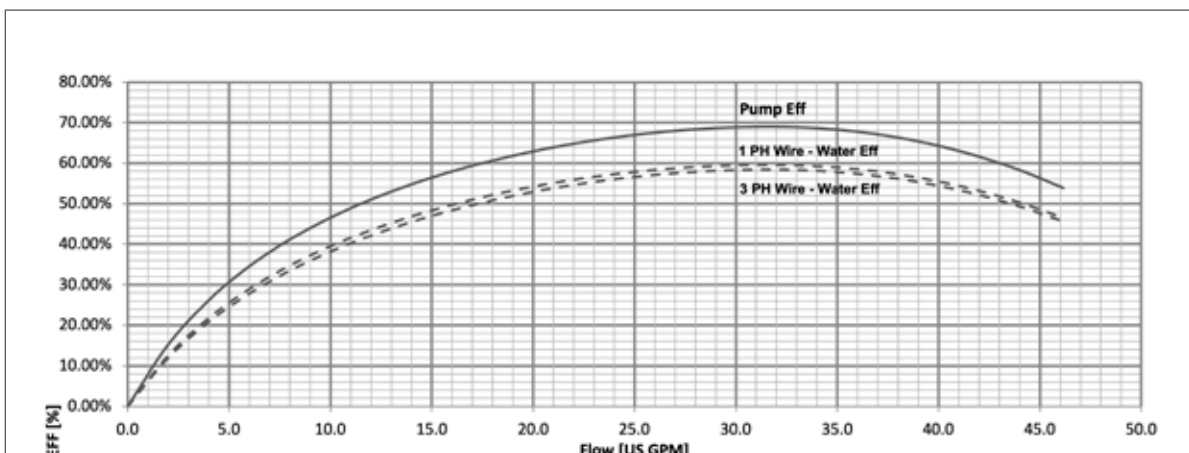
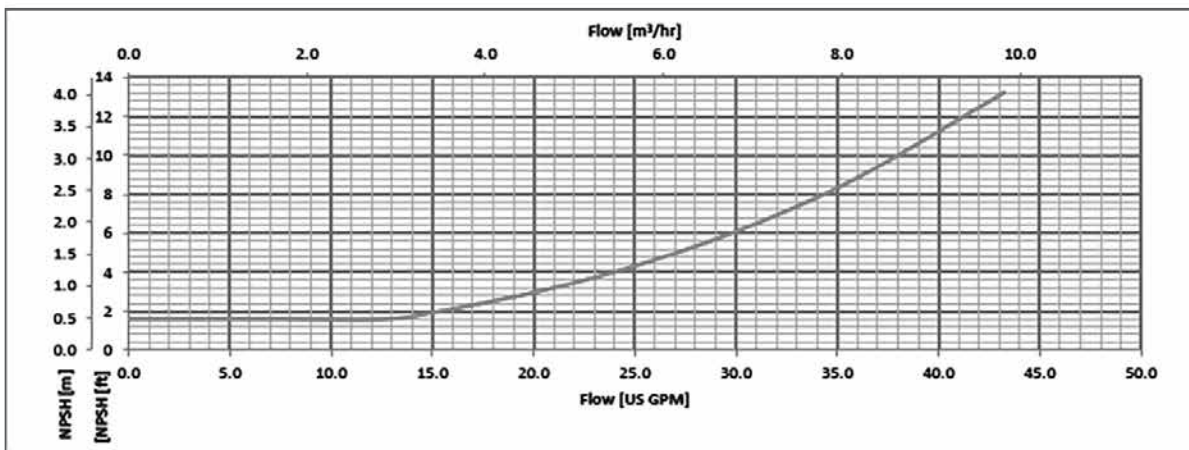
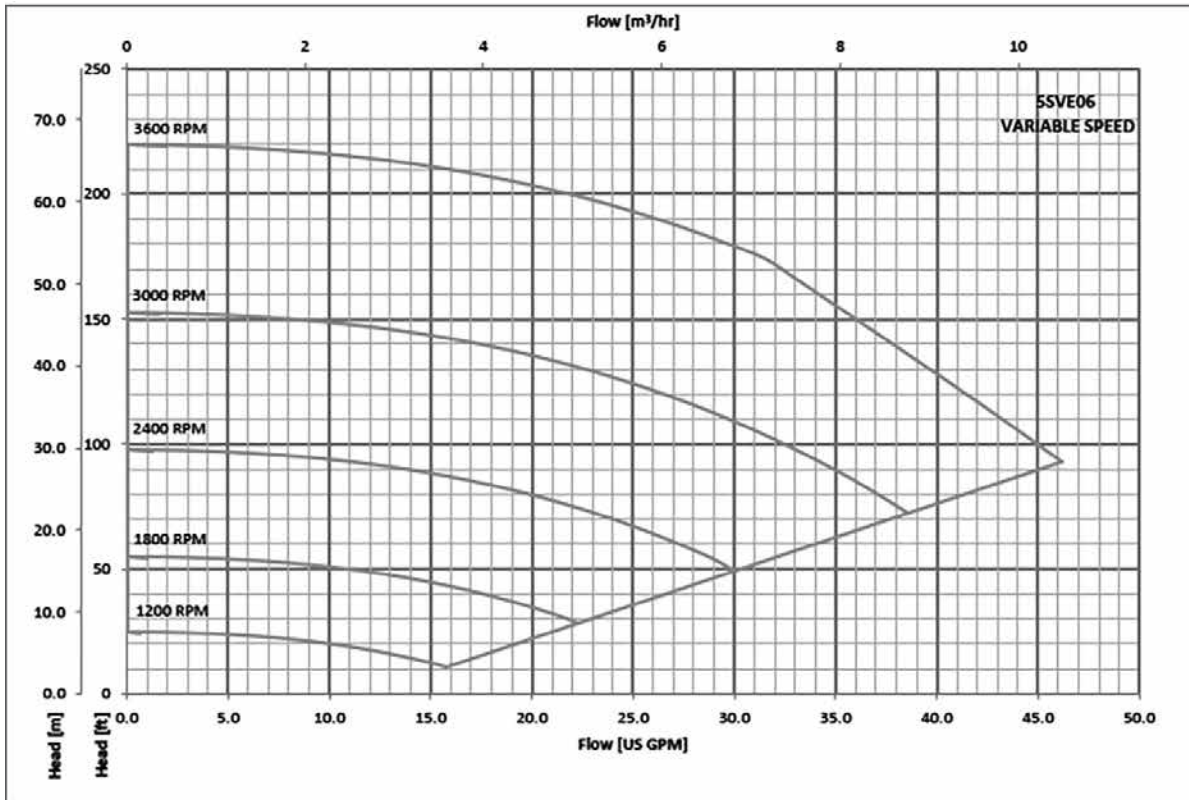

The performances are valid for liquid with density $\rho = 1.0 \text{ Kg/dm}^3$ and kinematic viscosity $\nu = 1 \text{ mm}^2/\text{sec}$.

5SVE SERIES OPERATING CHARACTERISTICS

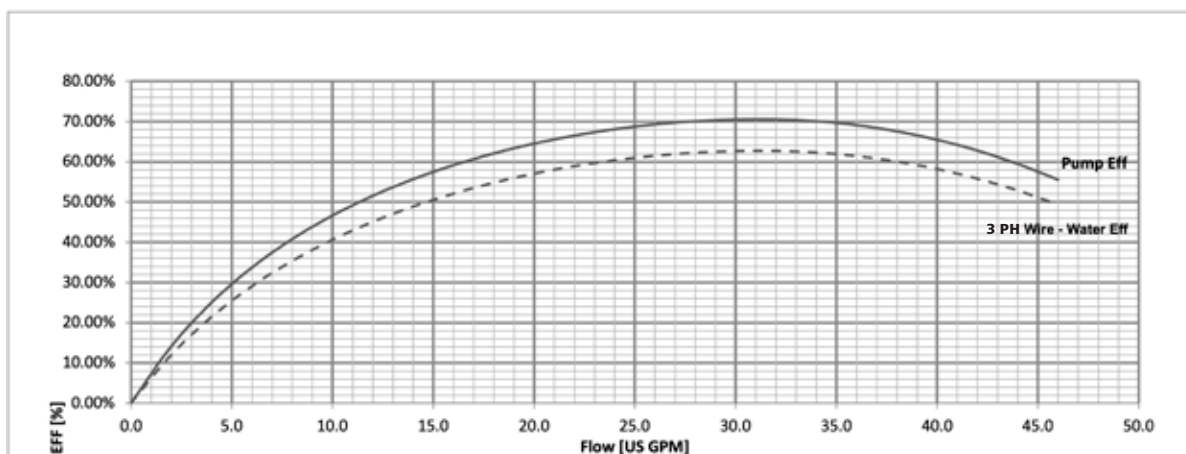
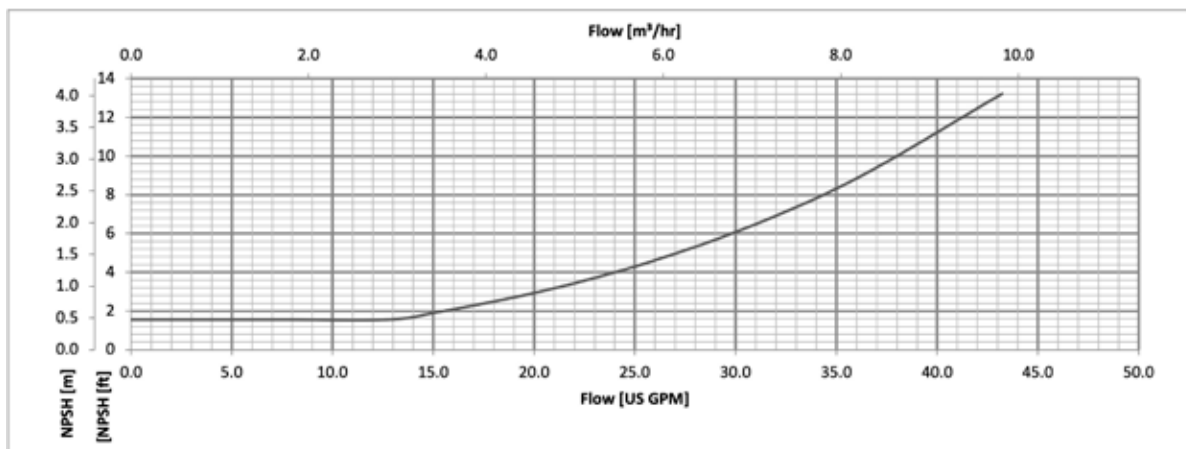
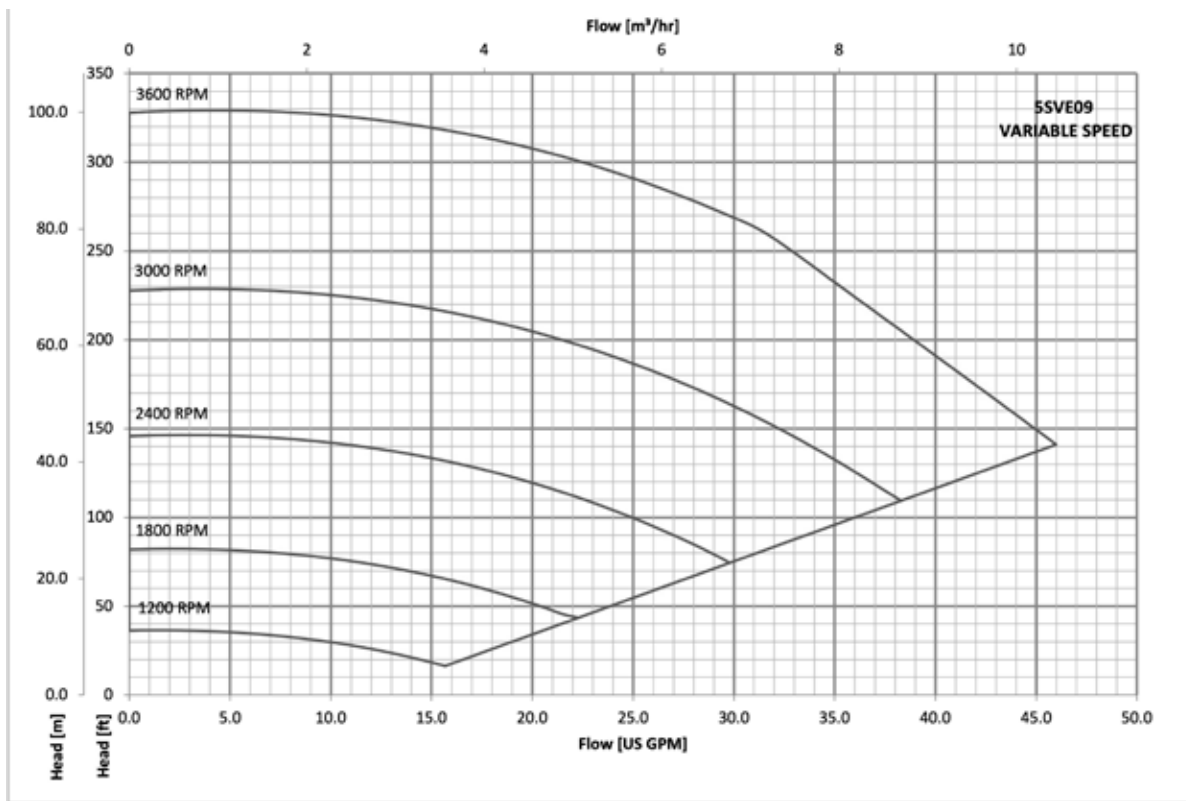

The performances are valid for liquid with density $\rho = 1.0 \text{ Kg/dm}^3$ and kinematic viscosity $\nu = 1 \text{ mm}^2/\text{sec}$.

10 SVE SERIES - SINGLE PHASE VERSION DIMENSIONS AND WEIGHTS

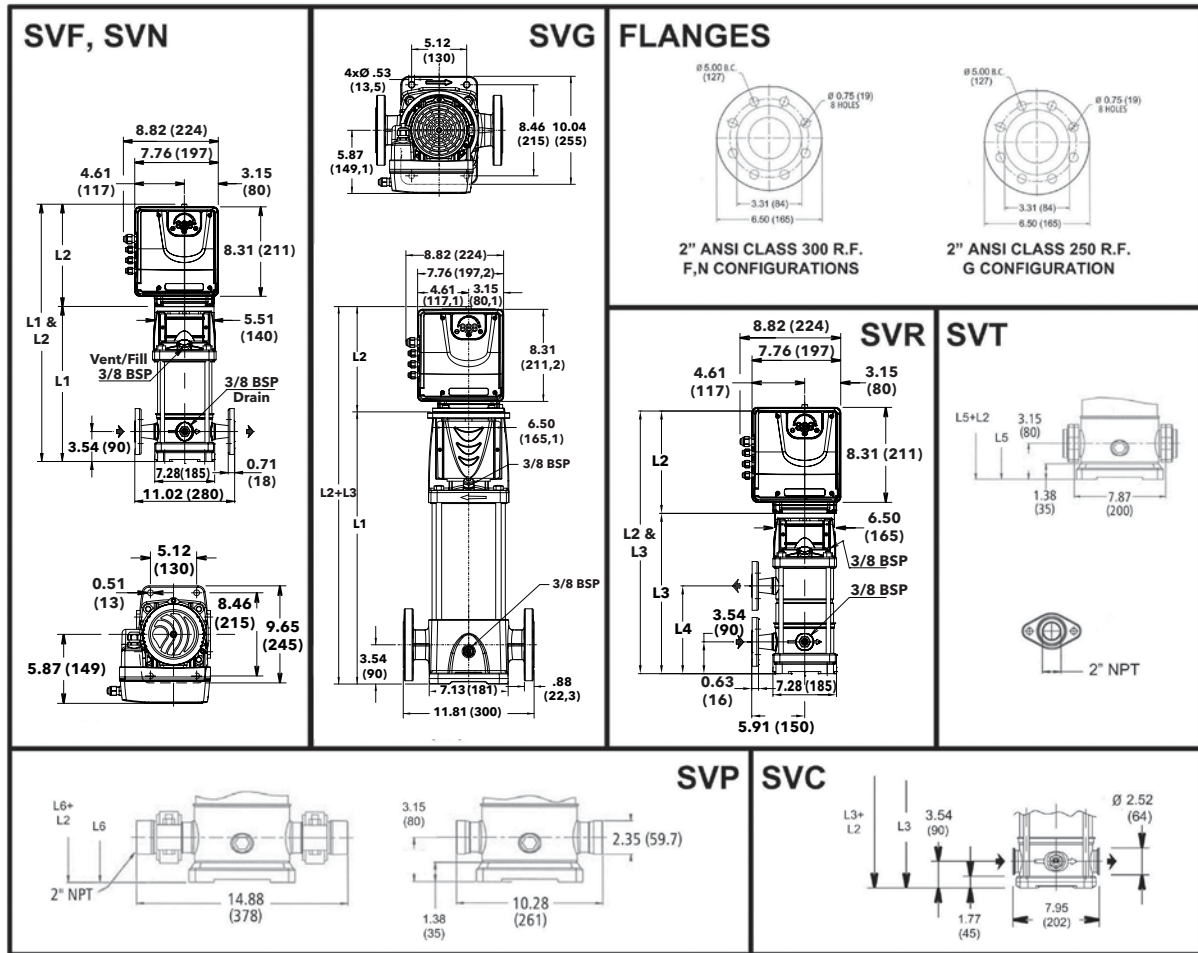

10SVE SERIES – 60 HZ, 3600 RPM TEFC ENCLOSURES

Pump Type Stages	Motor		Dimensions (in)								Weight (lbs)		
	P _N (HP)	Type 1 x 208-240 V	L1	L1 SVG	L2	L3	L4	L5	L6	D1 (max)	Pump Only	Motor	Pump/Motor
10SVE01	1	ESM90R/107 56C	16.95	17.01	9.53	-	-	16.17	16.17	5.20	36	16	52
10SVE02	2	ESM90R/115 56C	16.95	17.01	9.53	-	-	16.67	16.67	5.20	38	19	57

* Maximum value in specified range; PN = HP Rating; P1 = input power; I = input current.

10 SVE SERIES - THREE PHASE VERSION DIMENSIONS AND WEIGHTS

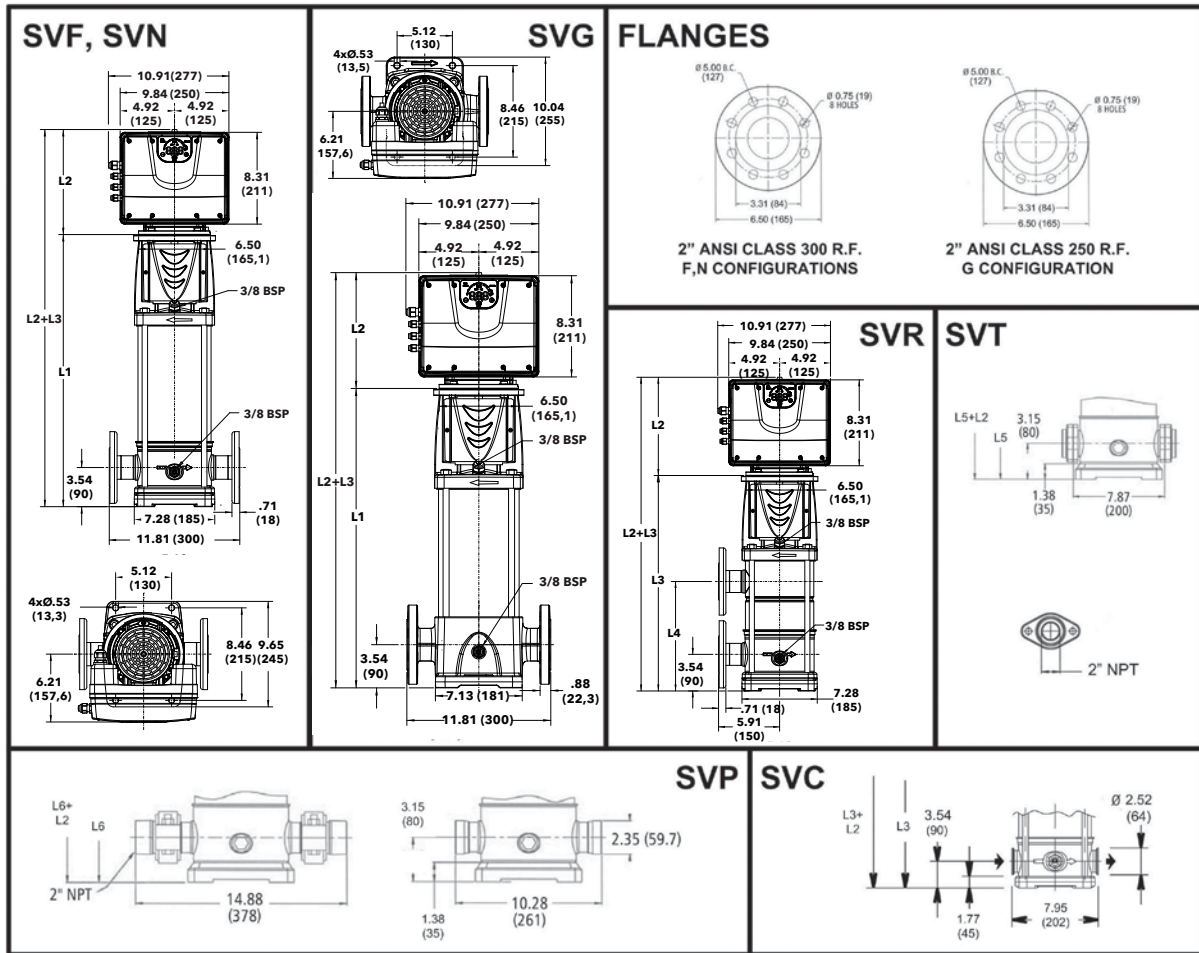

10SVE SERIES – 60 HZ, 3600 RPM TEFC ENCLOSURES

Pump Type Stages	Motor		Dimensions (in)								Weight (lbs)		
	HP	Type 3 x 208-240V 3 x 380-460V	L1	L1 SVG	L2	L3	L4	L5	L6	D1 (max)	Pump Only	Motor	Pump/Motor
10SVE01	1	ESM90R/307 56C	16.95	17.01	9.53	-	-	16.17	16.17	5.20	36	28	64
10SVE02	2	ESM90R/315 56C	16.95	17.01	9.53	-	-	16.67	16.67	5.20	38	32	70
10SVE03	3	ESM90R/322 56C	18.21	18.27	9.53	-	-	17.93	17.93	5.20	40	35	75

* Maximum value in specified range; PN = HP Rating; P1 = input power; I = input current.

10SVE SERIES OPERATING CHARACTERISTICS

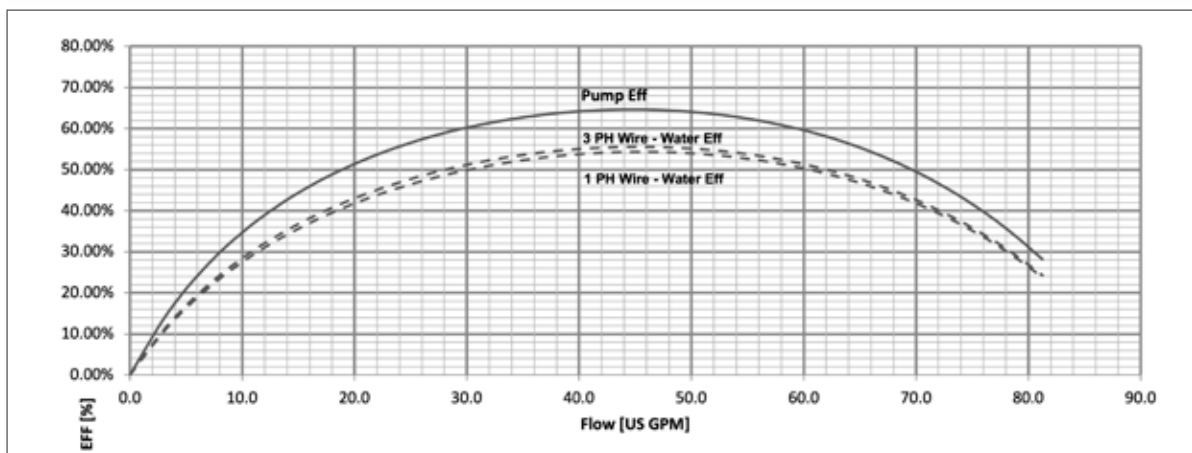
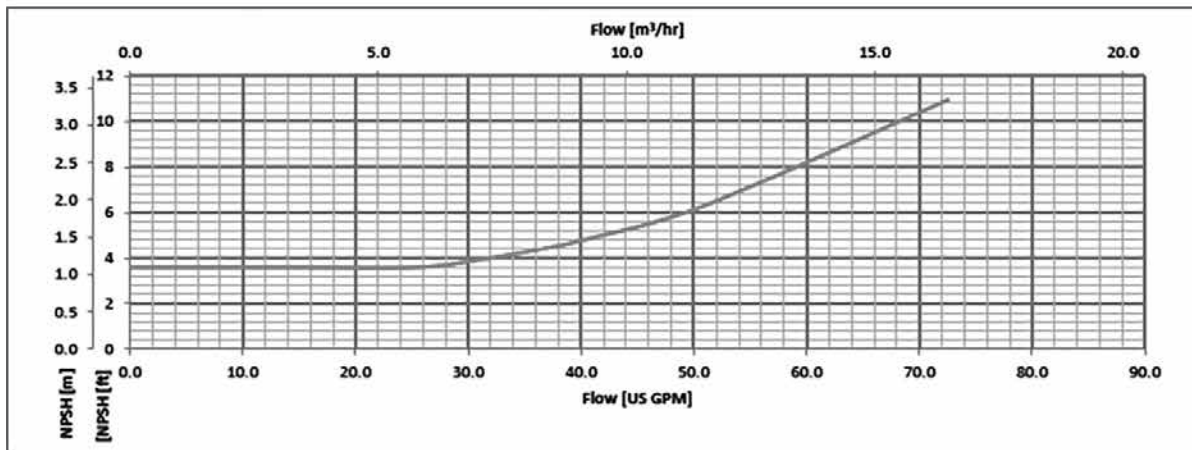
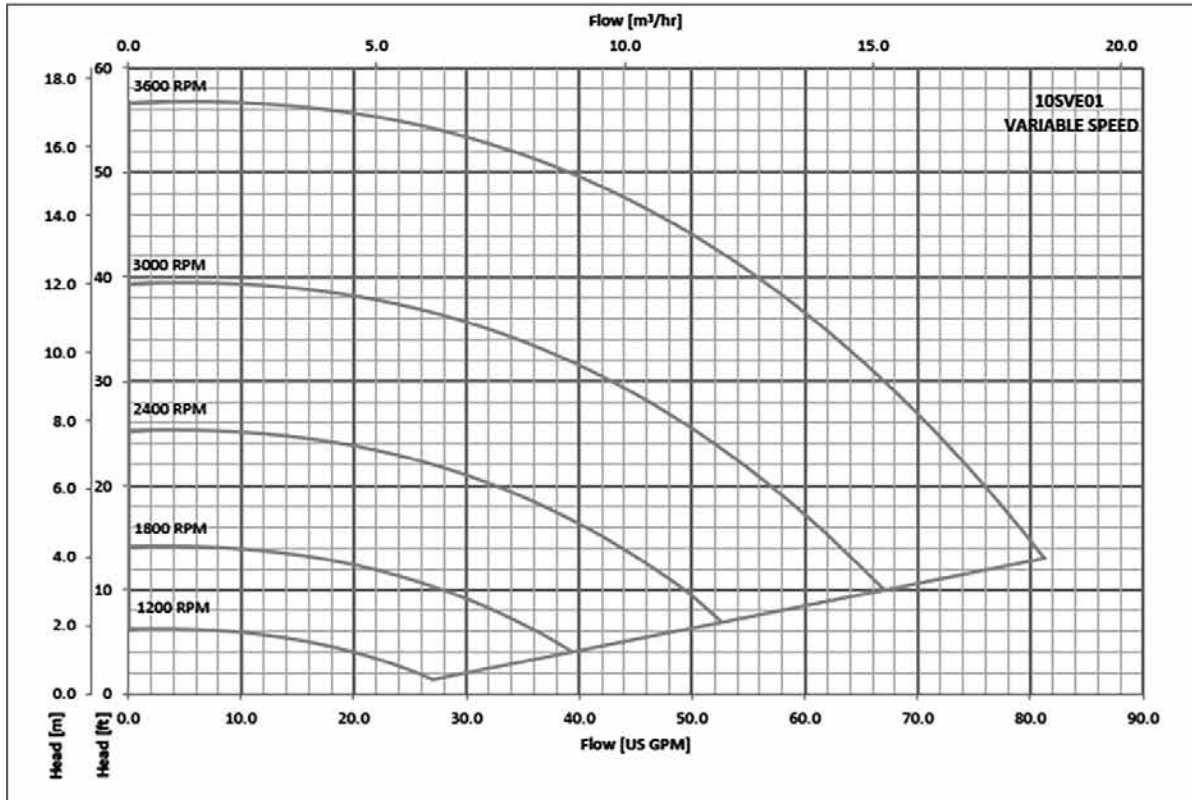

The performances are valid for liquid with density $\rho = 1.0 \text{ Kg/dm}^3$ and kinematic viscosity $\nu = 1 \text{ mm}^2/\text{sec}$.

10SVE SERIES OPERATING CHARACTERISTICS

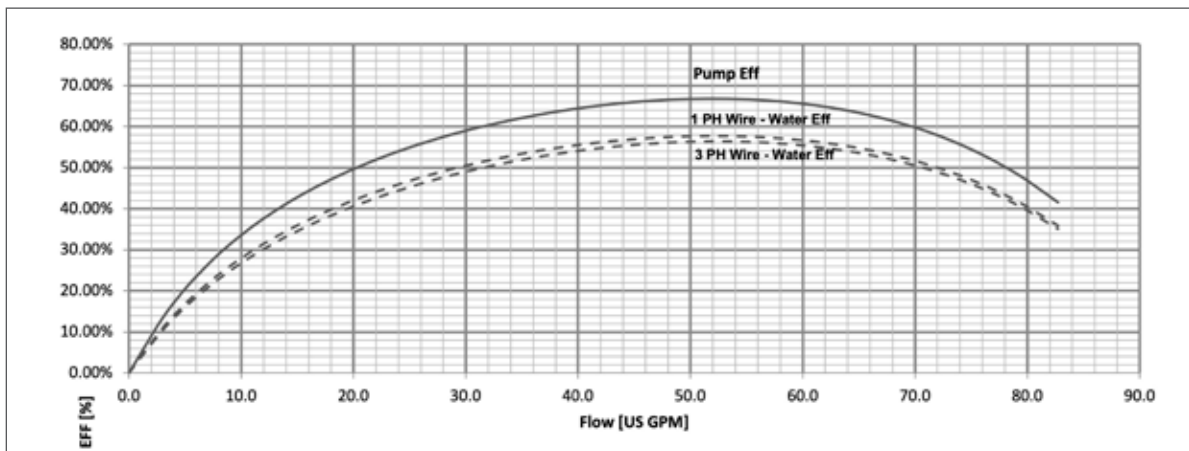
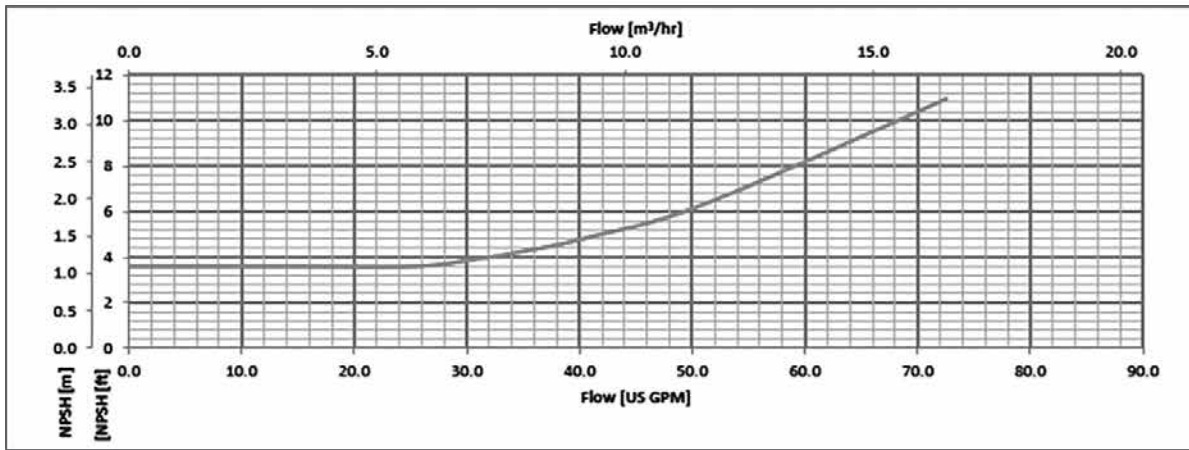
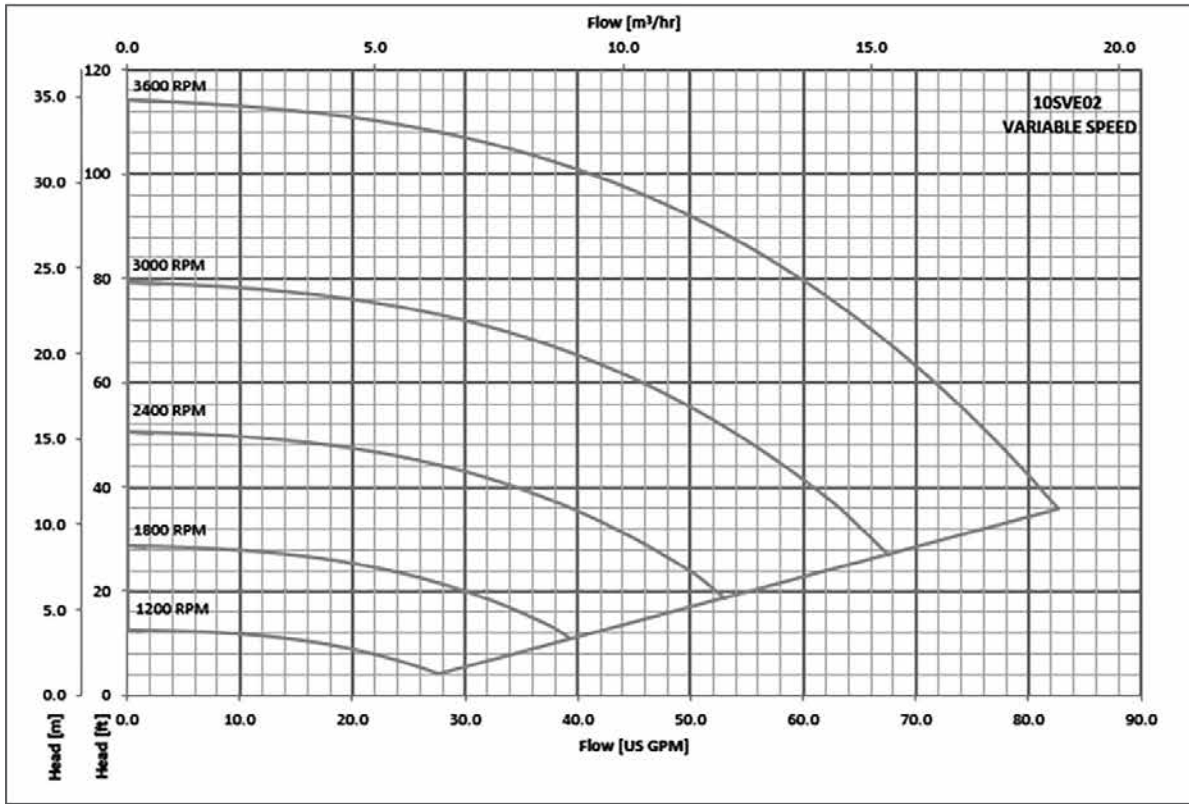

The performances are valid for liquid with density $\rho = 1.0 \text{ Kg/dm}^3$ and kinematic viscosity $\nu = 1 \text{ mm}^2/\text{sec}$.

10SVE SERIES OPERATING CHARACTERISTICS

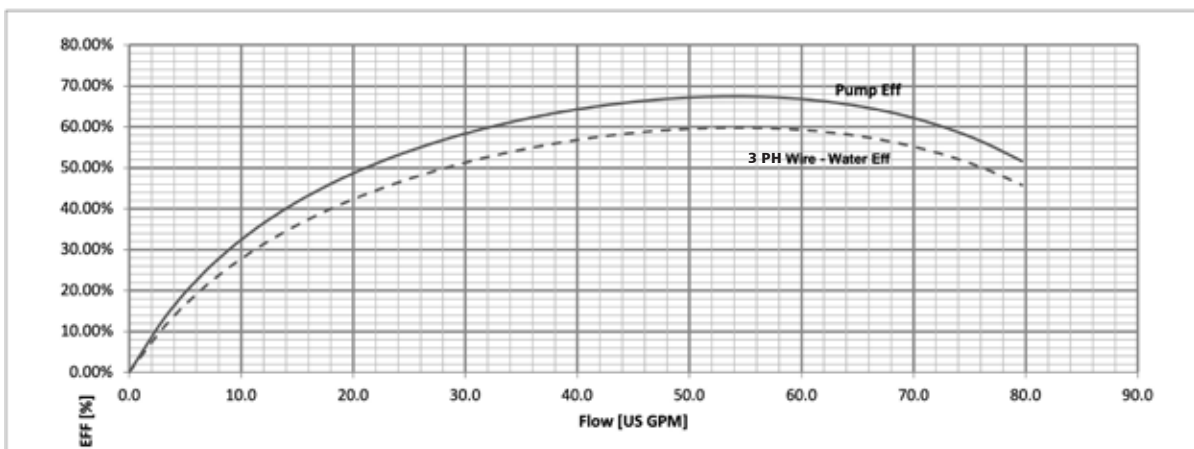
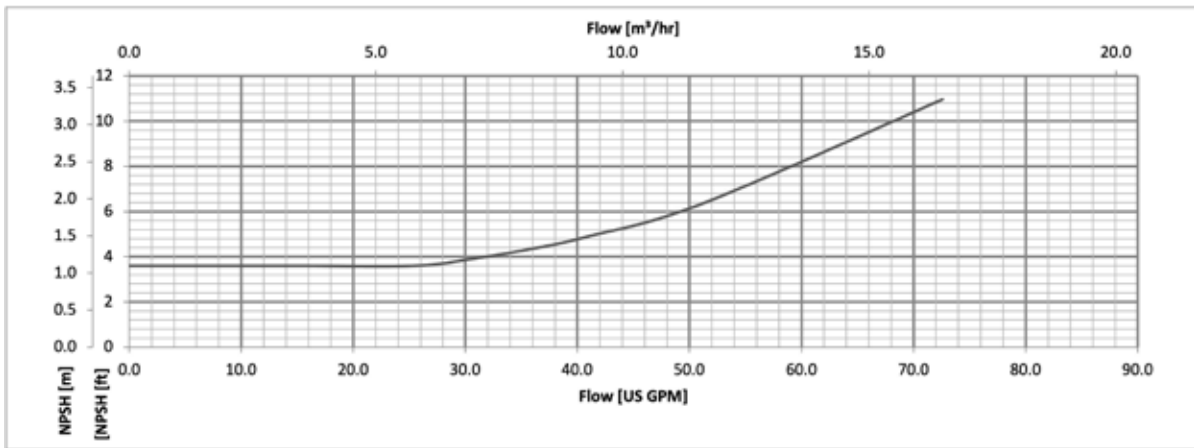
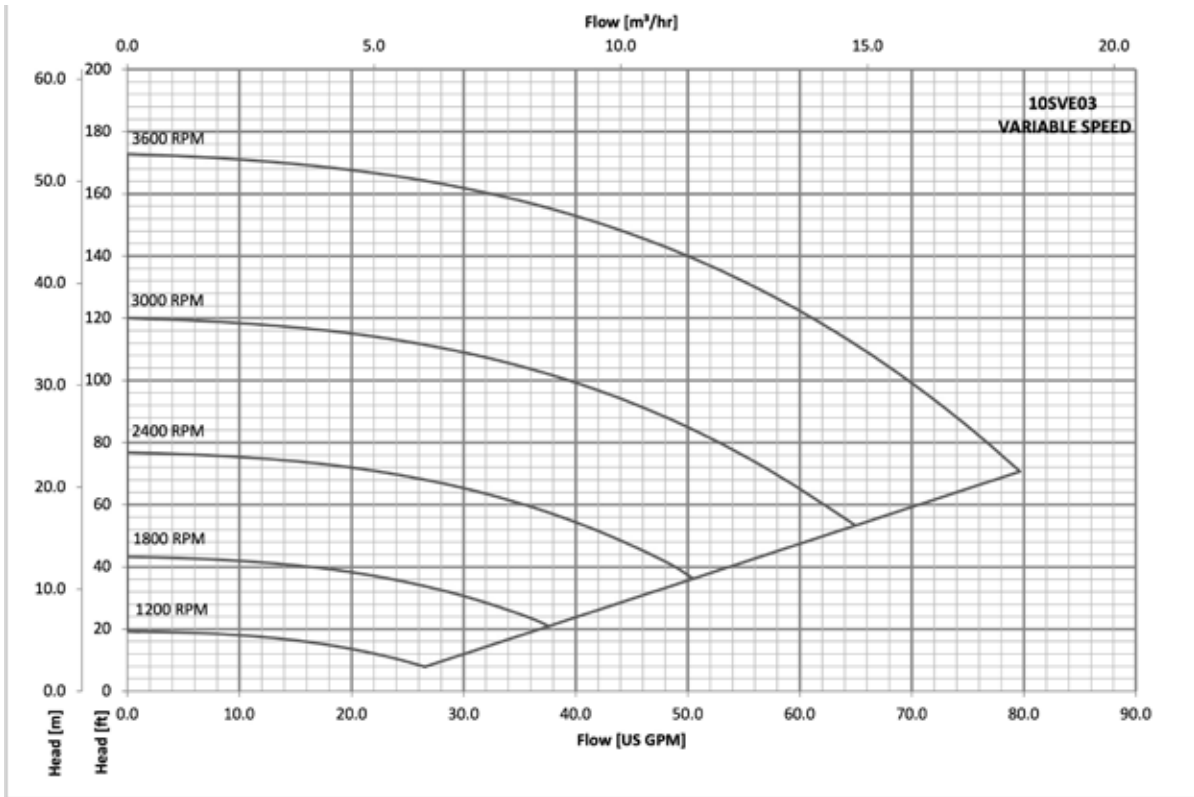

The performances are valid for liquid with density $\rho = 1.0 \text{ Kg/dm}^3$ and kinematic viscosity $\nu = 1 \text{ mm}^2/\text{sec}$.

Commercial Water

NPSH

The minimum operating values that can be reached at the pump suction end are limited by the onset of cavitation.

Cavitation is the formation of vapor-filled cavities within liquids where the pressure is locally reduced to a critical value, or where the local pressure is equal to, or just below the vapor pressure of the liquid.

The vapor-filled cavities flow with the current and when they reach a higher pressure the vapor contained in the cavities condenses. The cavities collide, generating pressure waves that are transmitted to the walls. These, being subjected to stress cycles, gradually become deformed and yield due to fatigue. This phenomenon, characterized by a metallic noise produced by the hammering on the pipe walls, is called incipient cavitation.

The damage caused by cavitation may be magnified by electrochemical corrosion and a local rise in temperature due to the plastic deformation of the walls. The materials that offer the highest resistance to heat and corrosion are alloy steels, especially austenitic steel. The conditions that trigger cavitation may be assessed by calculating the total net suction head, referred to in technical literature with the acronym NPSH (Net Positive Suction Head).

The NPSH represents the total energy (expressed in feet) of the liquid measured at suction under conditions of incipient cavitation, excluding the vapor pressure (expressed in feet) that the liquid has at the pump inlet.

A margin above the NPSH_r is necessary in order to achieve the pump's published performance and an adequate service life.

To find the static height (h_z) at which to install the machine under safe conditions, the following formula must be verified:

$$h_p + h_z \geq (\text{NPSH}_r + 2 \text{ feet}) + h_f + h_{pv}$$

where:

h_p is the absolute pressure applied to the free liquid surface in the suction tank, expressed in feet of liquid; h_p is the quotient between the barometric pressure and the specific weight of the liquid.

h_z is the suction lift between the pump axis and the free liquid surface in the suction tank, expressed in feet; h_z is negative when the liquid level is lower than the pump axis.

h_f is the flow resistance in the suction line and its accessories, such as: fittings, foot valve, gate valve, elbows, etc.

h_{pv} is the vapor pressure of the liquid at the operating temperature, expressed in feet of the liquid. h_{pv} is the quotient between the P_v vapor pressure and the liquid's specific weight.

0.5 is the safety factor.

The maximum possible suction head for installation depends on the value of the atmospheric pressure (i.e. the elevation above sea level at which the pump is installed) and the temperature of the liquid.

To help the user, with reference to water temperature (40°F) and to the elevation above sea level, the following tables show the drop in hydraulic pressure head in relation to the elevation above sea level, and the suction loss in relation to temperature.

Water Temperature (°C)	68	104	140	176	194	230	248
Suction Loss (ft)	-7	2.3	6.6	16.4	24.3	50.5	70.5

Elevation Above Sea Level (ft)	1600	3300	4900	6500	8200	9800
Suction Loss (ft)	1.8	3.6	5.4	7.2	9.0	10.8

To reduce it to a minimum, especially in cases of high suction head (over 13 - 16 feet) or within the operating limits with high flow rates, we recommend using a suction line having a larger diameter than that of the pump's suction port. It is always a good idea to position the pump as close as possible to the liquid to be pumped.

TECHNICAL DATA - WATER PROPERTY CHART

Temp °F	Temp °C	Specific Volume	Specific Gravity			Weight (lb/cubic ft)	Vapor Pressure (psi Abs)
		(Cubic ft/lb)	@ 39.2°F	@ 60°F	@ 68°F		
32	0.0	0.01602	1.000	1.001	1.002	62.42	0.088
35	1.7	0.01602	1.000	1.001	1.002	62.42	0.100
40	4.4	0.01602	1.000	1.001	1.002	62.42	0.122
50	10.0	0.01603	0.999	1.001	1.002	62.38	0.178
60	15.6	0.01604	0.999	1.000	1.001	62.34	0.256
70	21.1	0.01606	0.998	0.999	1.000	62.27	0.363
80	26.7	0.01608	0.996	0.998	0.999	62.19	0.507
90	32.2	0.0161	0.995	0.996	0.997	62.11	0.698
100	37.8	0.01613	0.993	0.994	0.995	62.00	0.949
120	48.9	0.0162	0.989	0.990	0.991	61.73	1.692
140	60.0	0.01629	0.983	0.985	0.986	61.39	2.889
160	71.1	0.01639	0.977	0.979	0.979	61.01	4.741
180	82.2	0.01651	0.970	0.972	0.973	60.57	7.510
200	93.3	0.01663	0.963	0.964	0.966	60.13	11.526
212	100.0	0.01672	0.958	0.959	0.960	59.81	14.696
220	104.4	0.01677	0.955	0.956	0.957	59.63	17.186
240	115.6	0.01692	0.947	0.948	0.949	59.10	24.97
260	126.7	0.01709	0.938	0.939	0.940	58.51	35.43
280	137.8	0.01726	0.928	0.929	0.930	58.00	49.20
300	148.9	0.01745	0.918	0.919	0.920	57.31	67.01
320	160.0	0.01756	0.908	0.909	0.910	56.66	89.66
340	171.1	0.01787	0.896	0.898	0.899	55.96	118.01
360	182.2	0.01811	0.885	0.886	0.887	55.22	153.04
380	193.3	0.01836	0.873	0.874	0.875	54.47	195.77
400	204.4	0.01864	0.859	0.860	0.862	53.65	247.31
420	215.6	0.01894	0.846	0.847	0.848	52.80	308.83
440	226.7	0.01926	0.832	0.833	0.834	51.92	381.59
460	237.8	0.0196	0.817	0.818	0.819	51.02	466.9
480	248.9	0.02	0.801	0.802	0.803	50.00	566.1
500	260.0	0.0204	0.785	0.786	0.787	49.02	680.8
520	271.1	0.0209	0.765	0.766	0.767	47.85	812.4
540	282.2	0.0215	0.746	0.747	0.748	46.51	962.5
560	293.3	0.0221	0.726	0.727	0.728	45.30	1133.1
580	304.4	0.0228	0.703	0.704	0.704	43.90	1325.8
600	315.6	0.0236	0.678	0.679	0.680	42.30	1542.9
620	326.7	0.0247	0.649	0.650	0.650	40.50	1786.6
640	337.8	0.026	0.617	0.618	0.618	38.50	2059.7
660	348.9	0.0278	0.577	0.577	0.578	36.00	2365.4
680	360.0	0.0305	0.525	0.526	0.527	32.80	2708.1
700	371.1	0.0369	0.434	0.435	0.435	27.10	3093.7

Commercial Water

VOLUMETRIC CAPACITY

Litres per minute l/min	Cubic metres per hour m ³ /h	Cubic feet per hour ft ³ /h	Cubic feet per minute ft ³ /min	Imp. gal. per minute Imp. gal./min	US gal. per minute US gal./min
1,0000	0,0600	2,1189	0,0353	0,2200	0,2640
16,6670	1,0000	35,3147	0,5886	3,6660	4,4030
0,4720	0,0283	1,0000	0,0167	0,1040	0,1250
28,3170	1,6990	60,0000	1,0000	6,2290	7,4800
4,5460	0,2728	9,6326	0,1605	1,0000	1,2010
3,7850	0,2271	8,0209	0,1337	0,8330	1,0000
0,1100	0,0066	0,2339	0,0039	0,0240	0,0290

PRESSURE AND HEAD

Newtons per square metre N/m ²	Kilopascal kPa	Bar bar	Pound Force per square inch psi	Metre of Water m H ₂ O	Millimetre of Mercury mm Hg
1,0000	0,0010	1 x 10 ⁵	1,45 x 10 ⁻⁴	1,02 x 10 ⁻⁴	0,0075
1000,0000	1,0000	0,0100	0,1450	0,1020	7,5000
100000,0000	100,0000	1,0000	14,5000	10,2000	750,1000
98067,0000	98,0700	0,9810	14,2200	10,0000	735,6000
6895,0000	6,8950	0,0690	1,0000	0,7030	51,7200
2984,0000	2,9840	0,0300	0,4330	0,3050	22,4200
9789,0000	9,7890	0,0980	1,4200	1,0000	73,4200
133,3000	0,1330	0,0013	0,0190	0,0140	1,0000
3386,0000	3,3860	0,0338	0,4910	0,3450	25,4000

LENGTH

Millimetre mm	Centimetre cm	Metre m	Inch in	Foot ft	Yard yd
1,0000	0,1000	0,0010	0,0394	0,0033	0,0011
10,0000	1,0000	0,0100	0,3937	0,0328	0,0109
1000,0000	100,0000	1,0000	39,3701	3,2808	1,0936
25,4000	2,5400	0,0254	1,0000	0,0833	0,0278
304,8000	30,4800	0,3048	12,0000	1,0000	0,3333
914,4000	91,4400	0,9144	36,0000	3,0000	1,0000

VOLUME

Cubic Metre m ³	Litre litre	Millilitre ml	Imp. Gallon imp. gal.	US Gallon US gal.	Cubic Foot ft ³
1,0000	1000,0000	1 x 10 ⁶	220,0000	264,2000	35,3147
0,0010	1,0000	1000,0000	0,2200	0,2642	0,0353
1 x 10 ⁻⁶	0,0010	1,0000	2,2 x 10 ⁻⁴	2,642 x 10 ⁻⁴	3,53 x 10 ⁻⁵
0,0045	4,5460	4546,0000	1,0000	1,2010	0,1605
0,0038	3,7850	3785,0000	0,8327	1,0000	0,1337
0,0283	28,3170	28317,0000	6,2288	7,4805	1,0000

TECHNICAL DATA - COMPATABILITY CHART FOR MATERIALS IN CONTACT WITH MOST COMMONLY USED LIQUIDS

Liquid	Concentration (%)	Temperature Min/Max °F	Specific Weight (lb/in ³)	SV 1, 3, 5, 10, 15, 22		SV 33, 46, 66, 92		Recommended Seal	Elastomers
				304	316	CI/316	316		
Water	100	23/248		•	•	•	•	Q;BEGG	E
Deionized, demineralized or distilled water	100	-13/230		•	•	•	•	Q;BEGG	E
Water and oil emulsion	any	23/194		•	•	•	•	Q;BVGG	V
Acetic acid (•)	80	14/158	.038	•	•	•	•	Q;BEGG	E
Citric acid	5	14/158	.056	•	•	•	•	Q;BEGG	E
Hydrochloric acid	2	23/77	.043		•		•	Q;Q;VGG	V
Phosphoric acid	10	23/86	.048		•		•	Q;BEGG	E
Nitric acid (•)	50	23/86	.053	•	•	•	•	Q;Q;VGG	V
Sulphuric acid (•)	2	14/77	.066		•		•	Q;BVGG	V
Tannic acid	20	32/122			•		•	Q;BEGG	E
Tartaric acid	50	14/77	.063	•	•	•	•	Q;Q;VGG	V
Uric acid	80	14/176	.068	•	•	•	•	Q;BEGG	E
Benzoic acid	70	32/158	.047	•	•	•	•	Q;BVGG	V
Boric acid	Saturated	14/194	.052	•	•	•	•	Q;Q;VGG	V
Formic acid (•)	5	5/77	.044	•	•	•	•	Q;BEGG	E
Ethyl alcohol (•)	100	23/104	.029	•	•	•	•	Q;BEGG	E
Methyl alcohol (•)	100	23/104	.029	•	•	•	•	Q;BEGG	E
Propyl alcohol (•)	100	23/176	.029	•	•	•	•	Q;BEGG	E
Butyl alcohol	100	23/176	.030	•	•	•	•	Q;BVGG	V
Denatured alcohol (•)	100	23/158	.030	•	•	•	•	Q;BEGG	E
Ammonia in water (•)	25	-4/122	.038	•	•	•	•	Q;BEGG	E
Chloroform		14/86	.053	•	•	•	•	Q;BVGG	V
Caustic soda	25	32/158	.077	•	•	•	•	Q;Q;EGG	E
Water, detergents, mineral oils mixture		23/176		•	•	•	•	Q;Q;VGG	V
Cleaning products		23/212		•	•	•	•	Q;Q;VGG	V
Glycerine	100	68/194	.046	•	•	•	•	Q;BEGG	E
Sodium Hypochlorite	1	14/77			•		•	Q;Q;VGG	V
Phosphates/polyphosphates		23/194			•		•	Q;Q;VGG	V
Sodium nitrate	Saturated	14/176	.081	•	•	•	•	Q;BEGG	E
Cutting fluid	100	23/230	.033	•	•	•	•	Q;BVGG	V
Peanut oil (•)	100	23/230	.034	•	•	•	•	Q;BEGG	E
Colza oil (•)	100	23/230	.034	•	•	•	•	Q;BEGG	E
Linseed oil (•)	100	23/230	.034	•	•	•	•	Q;BEGG	E
Coconut oil (•)	100	-4/194	.033	•	•	•	•	Q;BEGG	E
Soybean oil (•)	100	32/194		•	•	•	•	Q;BEGG	E
Diathermic oil	100	23/230	.033	•	•	•	•	Q;BVGG	V
Hydraulic oil	100	23/230		•	•	•	•	Q;BVGG	V
Mineral oil	100	23/230	.034	•	•	•	•	Q;BVGG	V
Sodium sulfate	15	14/104	.094	•	•	•	•	Q;Q;EGG	E
Aluminum sulfate	30	23/122	.097		•		•	Q;Q;EGG	E
Ammonium sulfate	10	14/140	.064		•		•	Q;Q;EGG	E
Iron sulfate	10	23/86	.076		•		•	Q;BEGG	E
Copper sulfate	20	32/86	.082		•		•	Q;Q;VGG	V
Trichloroethylene		14/104	.053	•	•	•	•	Q;BVGG	V
Perchloroethylene		14/86	.057	•	•	•	•	Q;BVGG	V

Legend

Q₁ = Silicon carbide B = Impregnated carbon E = EPDM V = Viton G = AISI 316 (spring, metal components)

(•) A special version may be necessary for this fluid. For additional information, please contact our sales network.

NOTES

Xylem |'zīləm|

- 1) The tissue in plants that brings water upward from the roots;
- 2) a leading global water technology company.

We're a global team unified in a common purpose: creating advanced technology solutions to the world's water challenges. Developing new technologies that will improve the way water is used, conserved, and re-used in the future is central to our work. Our products and services move, treat, analyze, monitor and return water to the environment, in public utility, industrial, residential and commercial building services settings. Xylem also provides a leading portfolio of smart metering, network technologies and advanced analytics solutions for water, electric and gas utilities. In more than 150 countries, we have strong, long-standing relationships with customers who know us for our powerful combination of leading product brands and applications expertise with a strong focus on developing comprehensive, sustainable solutions.

For more information on how Xylem can help you, go to www.xylem.com



Xylem Inc.
Phone: (866) 673-0428
Fax: (888) 322-5877
www.xylem.com/goulds