



ST51

SUBMERSIBLE SUMP/EFFLUENT PUMP



FEATURES

- Corrosion resistant construction
- Cast iron body
- Thermoplastic impeller and cover
- Upper sleeve and lower heavy duty ball bearing construction.
- Motor is permanently lubricated for extended service life.
- Powered for continuous operation.
- All ratings are within the working limits of the motor.
- Power cord, 10' standard length, heavy duty 16/3 SJTW with 115 volt grounding plug and vertical switch.
- Complete unit is heavy duty, portable and compact.
- Mechanical seal is carbon, ceramic, BUNA and stainless steel.
- Stainless steel fasteners

APPLICATIONS

Specially designed for the following uses:

- Basement Draining
- Dewatering
- Water Transfer
- Effluent Transfer

SPECIFICATIONS

Pump - General:

- Discharge: 1½" NPT
- Temperature: 104°F (40°C) maximum, continuous when fully submerged.
- Solids handling: ½" maximum sphere.
- Automatic models include a float switch.
- Pumping range: see performance chart or curve.

ST51 Pump:

- Maximum capacity: 61 GPM
- Maximum head: 29' TDH

AGENCY LISTINGS



Tested to UL 778 and CSA 22.2 108 Standards
By Canadian Standards Association
File #LR38549

PERFORMANCE RATINGS

ST51

Total Head (feet of water)	GPM
10	60
15	47
20	33
25	16

MOTOR

General:

- Single phase
- 60 Hertz
- 115 volts
- Built-in thermal overload protection with automatic reset.
- Class B insulation
- Oil-filled design
- High strength carbon steel shaft

ST51 Motor:

- .50 HP, 3400 RPM
- 115 volts
- PSC design

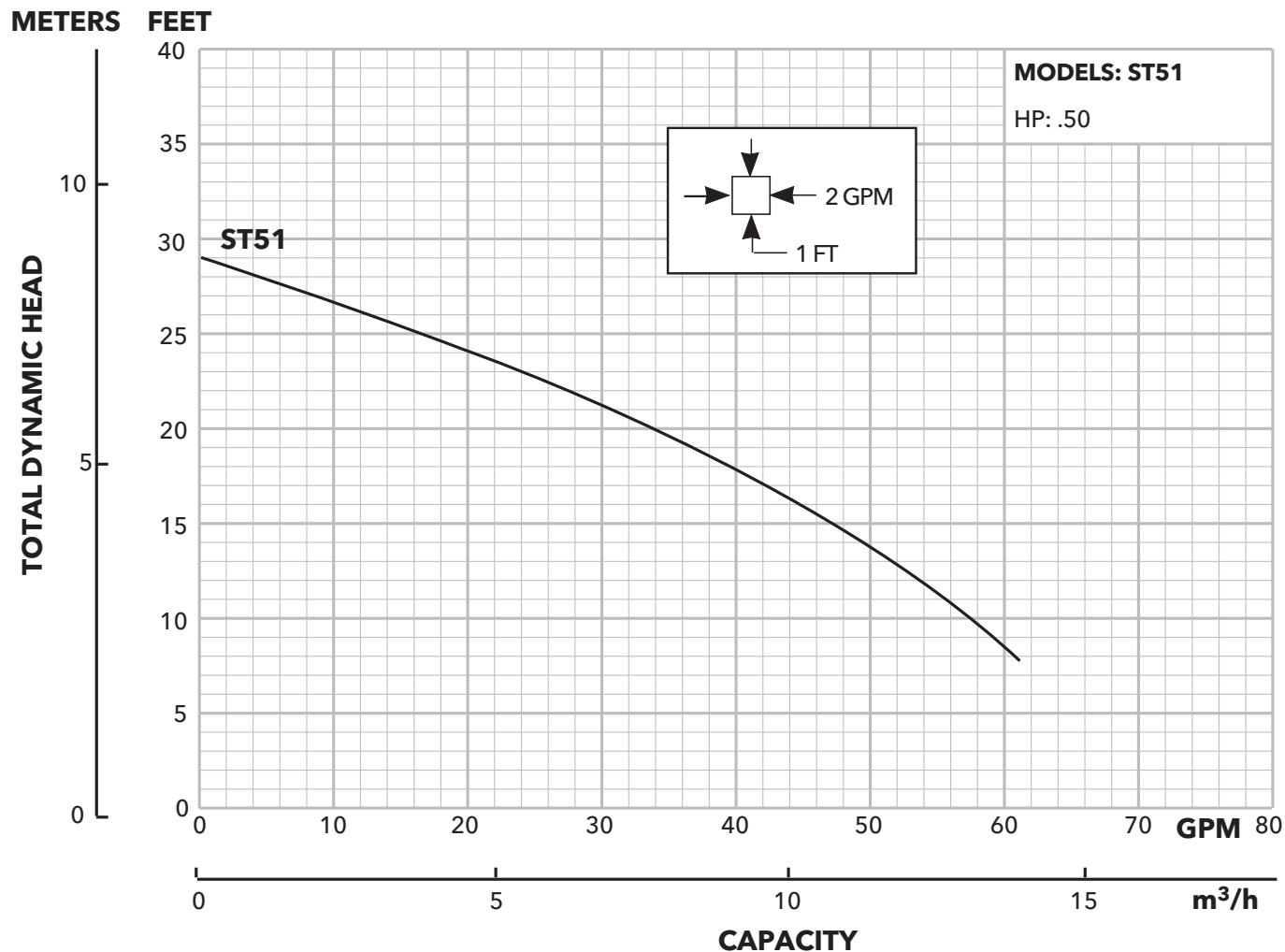

PUMP INFORMATION

Order No.	HP	Phase	Volt	Amp Draw	RPM	Float Switch Style	Cord Length	Discharge Connection	Minimum Basin Diameter	Maximum Solids Size	Shipping Weight lbs/kg
ST51AV	½	1	115	7.5	3450	Built-In Vertical	10'	1.5"	18"	.5"	31
ST51PV						Piggy-Back Vertical					
ST51P1						Piggy-Back Wide Angle					

DIMENSIONS

(All dimensions are in inches. Do not use for construction purposes.)

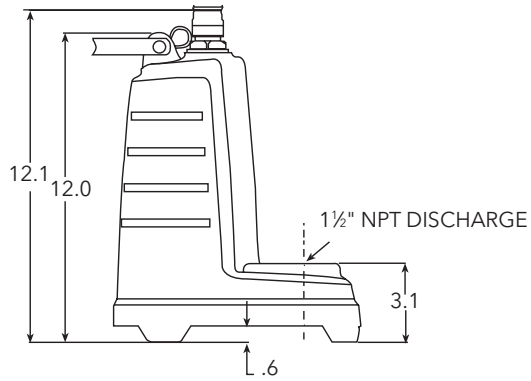
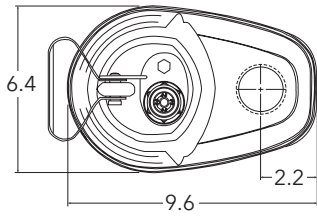

VERTICAL FLOAT SWITCH

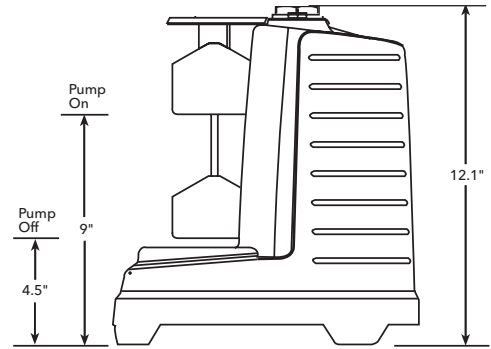
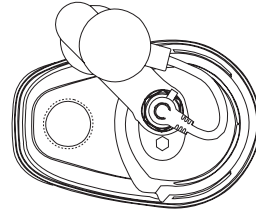

xylem
Let's Solve Water

Xylem Inc.
2881 East Bayard Street Ext., Suite A
Seneca Falls, NY 13148
Phone: (866) 325-4210
Fax: (888) 322-5877
www.xylem.com/goulds

Goulds is a registered trademark of Goulds Pumps, Inc. and is used under license.
© 2020 Xylem Inc. BST51 R1 March 2020