



RGZ2012 50 Hz
SUBMERSIBLE GRINDER PUMP



FEATURES

Design: Capable of grinding domestic sewage in individual residential applications.

Cutter System: Anti-roping design. Two blade rotary cutter is threaded to shaft. Stationary cutter ring is reversible for extended service.

Impeller: Silicon bronze, semi-open, non-overloading two-vane design with pump-out vanes for mechanical seal protection. Balanced for smooth operation.

Casing: Cast iron, volute type for high efficiency. Adaptable for slide rail system.

Motor Shaft: 300 series stainless steel, short over-hang for minimum shaft deflection.

Mechanical Seal: Hardfaced Silicon carbide for longer life, stainless steel metal parts, BUNA-N elastomers.

Paint: Electro-coat paint process protects all casting surfaces.

May be used with optional A10-12 stainless steel slide rail (1¼" NPT). Ordered separately.

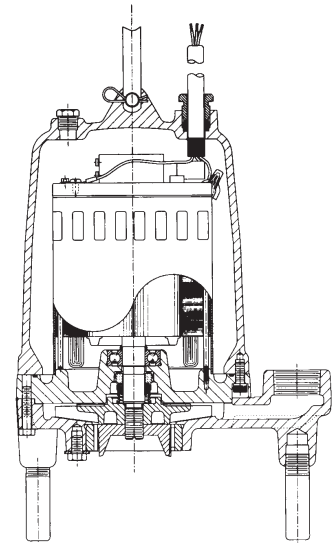

APPLICATIONS

Designed for high head sewage applications where a gravity system is not practical. Ideal for pressure sewage systems.

SPECIFICATIONS

Pump:

- Capacities: to 41 GPM
- Total heads: to 95' TDH
- Discharge: 1¼" NPT (STD)
- 1¼" BSPP (optional)
- Temperature:
104°F (40°C) maximum continuous
140°F (60°C) maximum intermittent.
- Single mechanical seal: silicon carbide rotary/silicon carbide stationary, 300 series stainless steel metal parts, BUNA-N elastomers.
- Fasteners: 300 series stainless steel.
- Rotating cutter and cutter ring: 440 C stainless steel, hardened to 55-60 Rockwell C.

Motor:

- Single phase: 2 HP, 50 Hz, 2900 RPM, 220 V, capacitor start with on winding thermal protector. No external capacitor kits required.
- Class F insulation

- Shaft: 300 series stainless steel threaded design
- Bearings: ball bearings upper and lower
- Power cord: 20 feet standard 14/3 STOW with bare leads. Optional lengths available.

MOTORS

- Fully submerged in oil-filled chamber. High grade turbine oil surrounds motor for more efficient heat dissipation, permanent lubrication of bearings and mechanical seal, and protection against outside environment.
- Designed for Continuous Operation: Pump ratings are within the motor manufacturer's recommended working limits, can be operated continuously without damage.
- Bearings: Upper and lower ball bearings for precision positioning of parts and to carry all radial loads and thrust loads.
- Power Cable: Severe duty rated, oil and water resistant. Epoxy seal on motor end provides secondary moisture barrier in case of outer jacket damage and to prevent oil wicking.
- O-ring: Assures positive sealing against contaminants and oil leakage.

AGENCY LISTINGS



Tested to UL 778 and CSA 22.2 108 Standards
By Canadian Standards Association File #LR38549

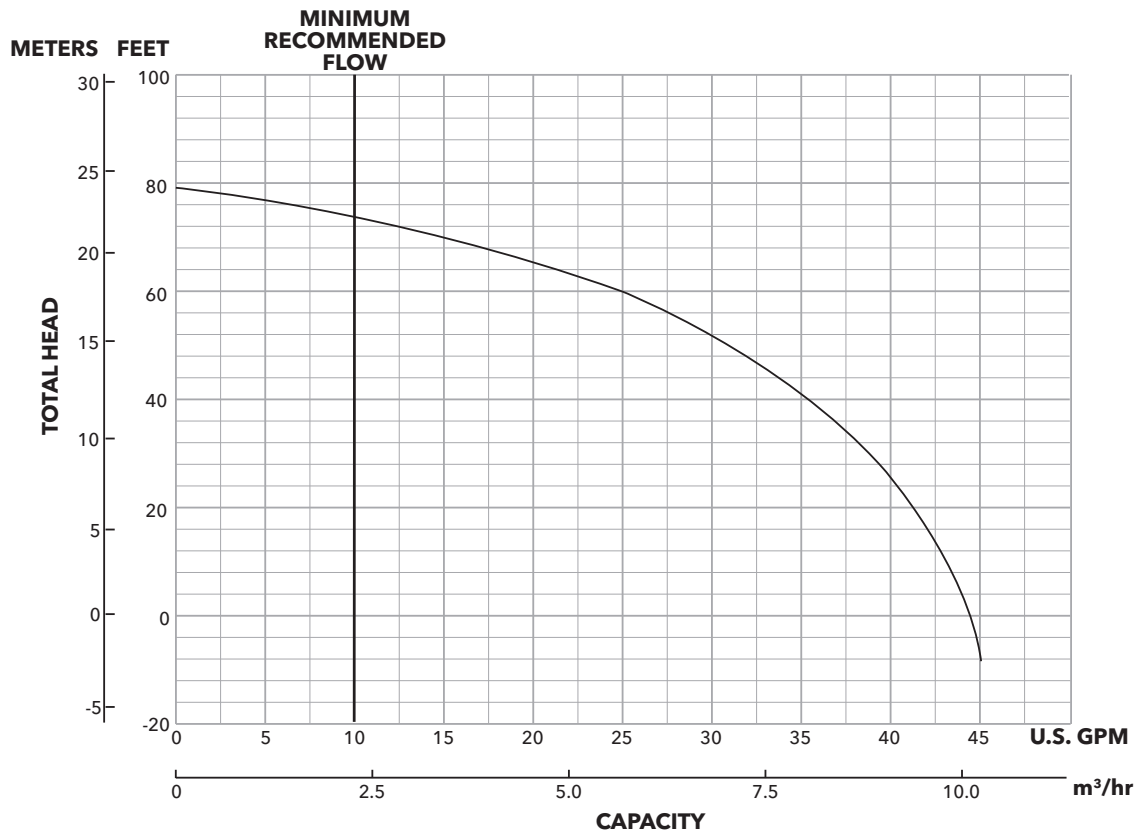

OPERATION OUTSIDE RECOMMENDED RANGE COULD AFFECT PUMP LIFE.

MOTOR DATA

HP	RPM	Voltage	Phase	Amps	KVA Code	Power Cable AWG	Fuse/Circuit Breaker Amps
2	2900	220	1	15.3	F	14/3	20

SERIES

Series	HP	RPM	Phase	Volts	Maximum Amps	Weight (lbs.)
RGZ2012	2	2900	1	220	15.3	75

**Optional Cord Lengths:

RGZ2012S	30' Power cord
RGZ2012U	50' Power cord
RGZ2012J	100' Power cord

** Price adds same as 3885Z, 3886Z and 3887Z. See Price Book.

CUTTER ASSEMBLY

2-Blade Rotating Cutter



Reversible Cutter Ring



APPLICATION DATA

Minimum Casing Thickness	5/16"
Casing Corrosion Allowance	1/8"
Maximum Working Pressure	50 PSI
Maximum Submergence	50 feet
Minimum Submergence	6" below top of motor dome
Maximum Environmental Temperature	40°C (104°F) continuous operation 60°C (140°F) intermittent operation
Minimum Basin Size	Simplex - 24" x 36" Fiberglass Duplex - 36" x 36" Fiberglass
Minimum Discharge Pipe Diameter	1 1/4"***
Maximum Discharge Pipe Diameter	2" *

* minimum 2 ft./sec. pipe velocity **must** be maintained (21 gpm minimum flow).

** minimum 2 ft./sec. pipe velocity **must** be maintained (10 gpm minimum flow).

CONSTRUCTION DETAILS

Power Cable - type	14/3, type STOW: single phase
Motor Cover	Gray cast iron - ASTM A48
Bearing Housing	Gray cast iron - ASTM A48
Seal Housing	Gray cast iron - ASTM A48
Casing	Gray cast iron - ASTM A48
Impeller	Cast silicon bronze - ASTM C87500
Motor Shaft	AISI 300 series stainless steel
Motor Design	NEMA 48 frame, oil filled with class F insulation
Motor Overload Protection	On winding thermal protector
External Hardware	300 series stainless steel
Impeller Type	Semi-opened with pump out vanes on back shroud
Cutter	Two blades; type 440C stainless steel
Oil Capacity - motor chamber	3.0 quarts

STANDARD PARTS

Ball Bearing - upper	Single row ball - SKF 6203-2Z
Ball Bearing - lower	Single row ball - SKF 6204-2Z
Mechanical Seal	Silicon carbide/silicon carbide; John Crane Type 21
O-Ring - motor cover	BUNA-N, AS 568A-166

DIMENSIONS

(All dimensions are in inches. Do not use for construction purposes.)

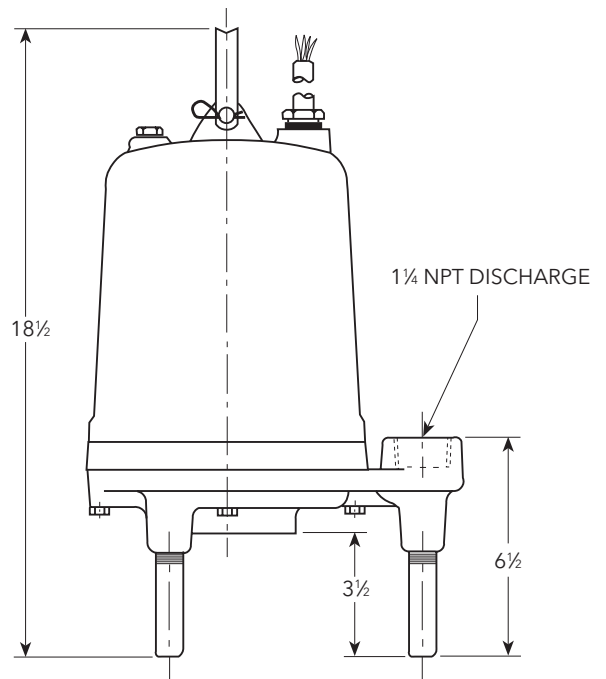
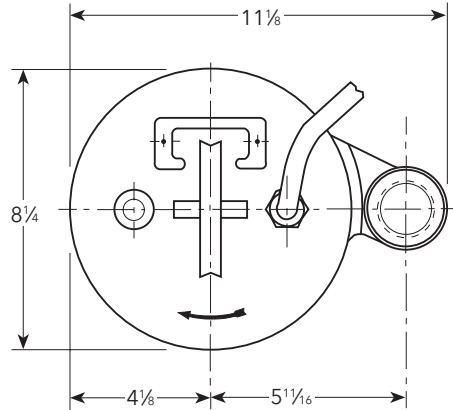

xylem
Let's Solve Water

Xylem Inc.
2881 East Bayard Street Ext., Suite A
Seneca Falls, NY 13148
Phone: (866) 325-4210
Fax: (888) 322-5877
www.gouldswatertechnology.com

Goulds is a registered trademark of Goulds Pumps, Inc. and is used under license.
© 2016 Xylem Inc. BRGZ2012 R1 February 2016