

NOW NSF LISTED!!



DRINKING WATER
NSF/ANSI 61 & 372

JRD JRD5, JRD7 AND JRD10

CONVERTIBLE JET PUMPS 1/2, 3/4 AND 1 HP - 60 HZ

FEATURES

Convertible: May be used on shallow or deep well applications using appropriate Goulds Water Technology fittings.

Serviceable:

- Back pullout design allows disassembly of pump for service without disturbing piping.
- Corrosion resistant, engineered plastic tubing and fittings are easily removed for cleaning. Premium O-ring design, fittings need only be hand tight to seal.

Impeller: F.D.A. compliant, glass filled engineered composite. Corrosion and abrasion resistant.

Diffuser (Guidevane): F.D.A. compliant, injection molded, food grade, glass filled engineered composite for durability and abrasion resistance.

Powered for Continuous Operation: Pump ratings are within the motor manufacturer's recommended working limits. Can be operated continuously without damage.

Corrosion Resistant: Electro-coat paint is baked on.

Excellent Air Handling Ability: After initial priming the pump has the ability to re-prime itself even when air enters the system. Pumping resumes once the water level rises above the foot valve.

Basic Pump Unit: Includes pump and motor, pressure switch with tubing and fittings.

Water system tank required on all systems.

NSF Listed: The first NSF listed jet pumps in the industry. All jet pumps and shallow well components only, deep well components are not listed.

APPLICATIONS

Specifically designed for:

- Homes • Farms • Cottages • Booster service

SPECIFICATIONS

Pump:

- Pipe connections: 1" NPT discharge, 1¼" NPT suction, 1" NPT pressure
- Pressure switch: AS4 preset at 30-50 PSI

Motor:

- Standard NEMA service factors
- 60 Hz, 3500 RPM, single phase
- ½ - 1 HP 115/230 V capacitor start
- Built-in overload with automatic reset
- Stainless steel shaft
- Rotation: clockwise when viewed from motor end

Maximum temperature: 140°F

ADDITIONAL COMPONENTS REQUIRED

- **Deep Well Package:** Choose either a twin pipe or packer style.

- Twin pipe includes jet body, nozzle, venturi and foot valve.

- Packer includes packer body, nozzle, venturi and built-in check valve.

NOTE: Packer systems also require an AWJ2 packer adapter on the wellhead.

- Deep well systems require a pressure control valve.

NOTE: You must have JDW or AV22KIT to make the pressure switch connection.

AGENCY LISTINGS



Canadian Standards Association
File #LR38549



DRINKING WATER
NSF/ANSI 61 & 372

PERFORMANCE RATINGS - SHALLOW WELL

Require pump and shallow well package shown below.

HP/Order No.	½ HP - JRD5					¾ HP - JRD7				1 HP - JRD10				
Shallow Well Package (includes the components below)	FH5JRD					FH7				FH10				
Adapter	4K62					4K62				4K62				
Nozzle	AN018					AN018				AN018				
Venturi	AD3731					AD3536				AD3538				
Total Suction Lift (feet)	Discharge Pressure - PSI					Discharge Pressure - PSI				Discharge Pressure - PSI				
	20	30	40	50	Max. Shut-off (PSI)	30	40	50	Max. Shut-off (PSI)	30	40	50	60	Max. Shut-off (PSI)
	Gallons per minute					Gallons per minute				Gallons per minute				
5	12.3	12.0	9.0	4.0	63	19.0	16.5	10.5	69	22.0	21.0	15.0	8.0	72
10	11.0	10.8	7.6	3.0	62	16.0	14.5	9.0	67	18.5	18.0	12.5	6.5	70
15	9.2	9.0	6.5	2.5	60	13.5	13.0	7.0	65	16.0	15.5	11.0	5.0	68
20	7.6	7.5	5.5	1.5	57	12.0	11.5	5.5	63	13.3	13.0	9.0	3.0	65
25	5.7	5.5	4.0	0.6	55	9.0	8.7	4.0	60	9.6	9.0	7.0	1.5	63

Residential Water Systems

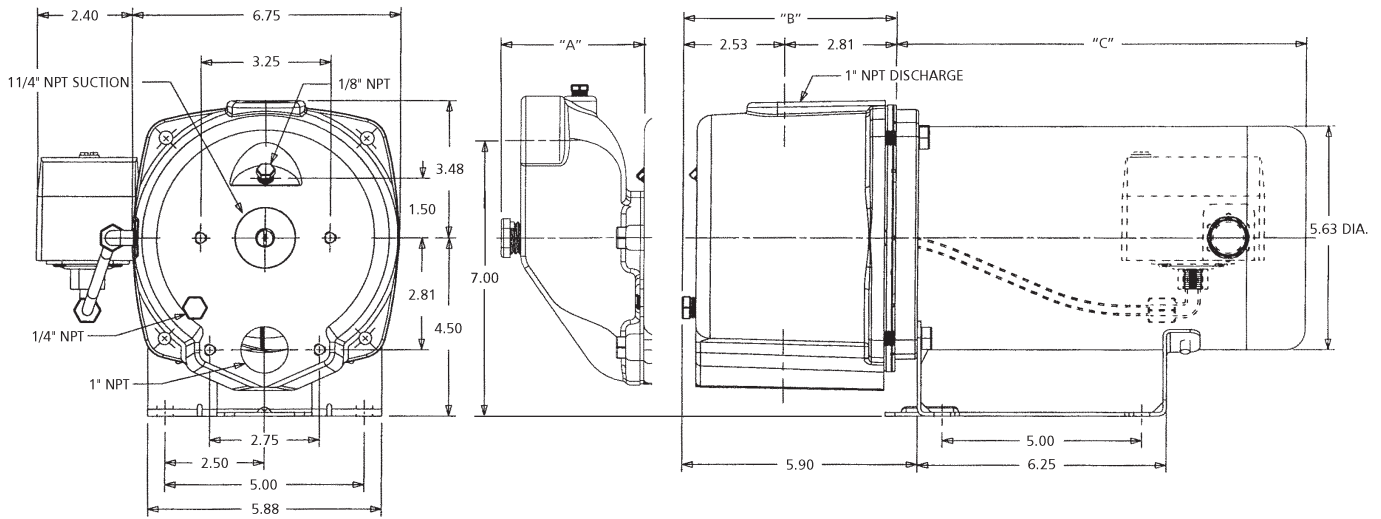

DIMENSIONS AND WEIGHTS - PUMP, MOTOR AND SHALLOW WELL ADAPTER

Order No.	HP	(Inches)				Height (Inches)		Wt. (lbs.)
		Opt. SW Adapter "A"	"B"	"C" Max.	Width	Shallow Well	Deep Well	
JRD5	1/2	3.31	5.34	10.81	9.15	8.41	8.0	37
JRD7	3/4			11.56				42
JRD10	1			11.81				47

Do not use for construction purposes.

TWIN PIPE PERFORMANCE RATINGS

HP/Order No.	1/2 HP - JRD5				3/4 HP - JRD7				1 HP - JRD10						
Well Casing Min. I.D. (in.)	3	4	4 1/2	4	4 1/2	4	4 1/2	4	4 1/2	4	4 1/2	4	4 1/2		
Pressure Suction Pipe Size (in.)	3/4	1	1 1/4	1	1 1/4	1	1 1/4	1	1 1/4	1	1 1/4	1	1 1/4		
	1	1 1/4	1 1/2	1 1/4	1 1/2	1 1/4	1 1/2	1 1/4	1 1/2	1 1/4	1 1/2	1 1/4	1 1/2		
Jet Assembly Package	FT3B-09	FT4B-13	FT4B-31	FT4B-08	FT5B-14	FT4B-14	FT4B-34	FT4B-18	FT5B-47	FT5B-48	FT4B-44	FT4B-43	FT4B-18	FT5B-49	FT5B-11
Jet Body (Only)	AT3B	AT4B		AT5B	AT4B		AT5B	AT5B		AT4B		AT5B			
Nozzle	AN015	AN017	AN016	AN015	AN018	AN017	AN016		AN018	AN017		AN016	AN019	AN018	
Venturi	AD722	AD726	AD723	AD720	AD724	AD729	AD725	AD722	AD730	AD725	AD730	AD727	AD722	AD732	AD727
Control Valve Setting (PSI)	30									31	33	35	30	32	
Feet	Gallons Per Minute (GPM) 30-50 PSI Pressure Switch Setting														
Depth to Jet Assembly (Based on Submergence of 5 Feet)	30	6.4	11.7	10.0			13.3			14.3		14.5		16.3	
	40	5.7	10.7	8.0			13.2			14.2		14.3		16.3	
	50	4.3	9.3	6.8			11.3			13.0		12.3		15.3	
	60			6.2	4.7		8.8	8.0		11.5		9.8	9.5	13.0	
	70			5.0	4.2	5.0	7.0			9.8	8.3	8.0		10.8	
	80				3.3	4.3	5.7			7.3		6.3	5.3	8.7	8.8
	90				2.8	3.7	4.2	4.5		6.3			5.2	7.5	
	100							3.7		5.3			4.7	6.2	
	110							3.0		4.3			3.8	4.8	
	120													3.8	

② Jet Assembly Package includes: Jet Body, Venturi, Nozzle, Foot Valve.
 Important: An offset of 50 feet will result in a decrease of about 25% from ratings as shown.

PACKER SYSTEM PERFORMANCE RATINGS

HP/Order No.	½ HP - JRD5			¾ HP - JRD7		1 HP - JRD10		
Well Casing	2							
Suction Pipe Size (in.)	1¼							
① Jet Assembly Package	FP2-13	FP2-31	FP2-08	FP2-40	FP2-47	FP2-48	FP2-43	
Jet Body (Only)	AP2			AP2		AP2		
Nozzle	AN017	AN016	AN015	AN015		AN016		
Venturi	AD726	AD723	AD720	AD727	AD723	AD729	AD725	
Control Valve Setting (PSI)	30			30	32	35	36	
	Feet	Gallons Per Minute (GPM) 30-50 PSI Pressure Switch Setting						
Depth to Jet Assembly (Based on Submergence of 5 Feet)	30	10.7	8.5		11.8		14.2	
	40	9.5	7.3		11.5		12.5	
	50	8.3	6.7		9.8		11.5	
	60		5.8	4.3	7.7	6.7	9.3	7.8
	70			3.8		6.0		7.7
	80			3.2		4.3		6.3
	90					3.7		4.8
	100							3.7
	110							
	120							

① Jet Assembly Package includes: Jet Body, Venturi, Nozzle, Built-in Check Valve, Leather Crimps, Spacer and Fitting.
 Important: An offset of 50 feet will result in a decrease of about 25% from ratings as shown.

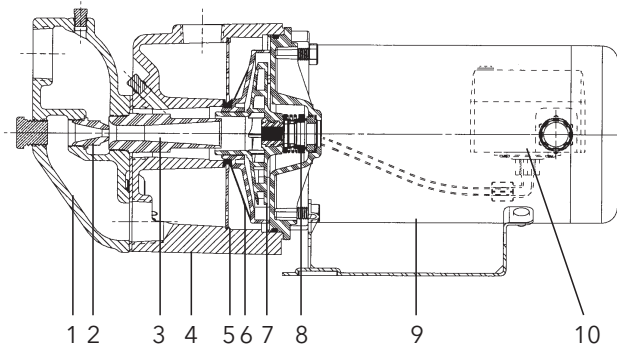
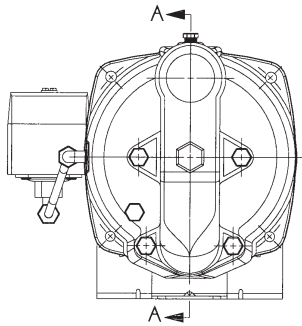

COMPONENTS

Item No.	Description
1	Shallow well adapter
2	Nozzle
3	Venturi
4	Cast iron casing
5	Separator plate
6	Diffuser (Guidevane)
7	Impeller
8	Mechanical seal
9	Motor
10	Pressure switch



Xylem Inc.
 2881 East Bayard Street Ext., Suite A
 Seneca Falls, NY 13148
 Phone: (866) 325-4210
 Fax: (888) 322-5877
www.xylem.com/goulds

Xylem is a registered trademark of Xylem, Inc., or one of its subsidiaries. Goulds is a registered trademark of Goulds Pumps, Inc. and is used under license.
 © 2022 Xylem Inc. BJRD R3 May 2022