



JRS5X, JRS5K, JRS5L, JRD5X, JRD5K, JRD5L

PUMP AND TANK PACKAGES

TANK FEATURES

Deep Drawn Steel Shells: Provide maximum material strength.

Inner Shell: Prevents diaphragm from over-expanding.

Heavy Duty Diaphragm: Made of finest quality butyl rubber. Separates air and water, maintains air charge.

Interior Tank Lining: Fusion bonded polymeric lining (durable polypropylene liner used on V15P). Both meet FDA requirements.

Maximum Working Pressure: 100 PSI for V45PST and V60PST, 125 PSI for V15P.

Tank Temperature Rating: Maximum 120° F.

Appliance Appearance Exterior Finish: High durability exterior finish of tough, powder coat over a zinc phosphate surface treatment.

Heavy Duty Base: Eliminates corrosion due to condensation and exposure to the elements. Made of high density polypropylene.

Tanks are designed for installation indoors or where they are protected from rain, irrigation overspray, salt air and other corrosive environments. Always protect tanks from freezing.

ORDER INFORMATION

Model No.	HP	Replacement Pump Model No.	Tank Model	Drawdown at	
				20/40 PSI	30/50 PSI
JRD5X	½	JRD5	V15P	1.7	1.4
JRD5K	½	JRD5LT	V45PST	5.1	4.3
JRD5L	½	JRD5LT	V60PST	7.3	6.1
JRS5X	½	JRS5	V15P	1.7	1.4
JRS5K	½	JRS5LT	V45PST	5.1	4.3
JRS5L	½	JRS5LT	V60PST	7.3	6.1

AGENCY LISTINGS



DRINKING WATER
NSF/ANSI 61 & 372

APPLICATIONS

Home, farm and cottage water systems and booster service.

PUMP SPECIFICATIONS

Pump:

- Pipe connections: 1" NPT pressure, 1¼" NPT suction, 1" NPT discharge
- Pressure switch: AS4 preset 30-50 PSI

Motor:

- NEMA service factor
- 60 Hz, 3500 RPM
- ½ HP, 115/230 V capacitor start
- Built-in overload with automatic reset
- Stainless steel shaft

PUMP FEATURES

JRS models have an integral shallow well jet built into the casing, which eliminates the need for a separate shallow well adapter.

JRD models require a deepwell jet assembly package that must be ordered SEPARATELY.

See twin pipe performance rating chart for jet assembly package order number.

Serviceable:

- Back pullout design allows disassembly of pump for service without disturbing piping.
- Two compartment motor for easy access to motor wiring and replaceable components.
- Corrosion resistant, engineered plastic tubing and fittings are easily removed for cleaning. Premium o-ring design fittings need only be hand tight to seal.

Powered for Continuous Operation: Pump ratings are within the motor manufacturer's recommended working limits. Can be operated continuously without damage.

Corrosion Resistant: Electro-coat paint is applied inside and out, then baked on.

Excellent Air Handling Ability: After initial priming the pump has the ability to re-prime itself even when air gets into the system.

Drain Plug: For ease of winterizing and maintenance.

Seal Housing: Engineered composite. Corrosion and abrasion resistant.

Impeller: F.D.A. compliant, glass filled engineered composite.

Diffuser (Guidevane): F.D.A. compliant, injection molded, food grade, glass filled engineered composite.

NSF Listed: The first NSF listed jet pumps in the industry. All jet pumps and shallow well components only, deep well components are not listed.

PERFORMANCE RATINGS

Shallow Well Systems

HP/Order No.	½ HP-JRS5				
Nozzle	AN018				
Venturi	AD3330				
Total Suction Lift (Feet)	Discharge Pressure - PSI				
	20	30	40	50	Maximum Shut-off (PSI)
	Gallons Per Minute				
5	14.1	13.3	10.5	5.8	64
10	12.4	12.0	9.2	4.2	59
15	10.5	10.0	8.0	2.4	56
20	8.6	8.5	6.6	1.0	53
25	6.7	6.5	5.0	0.6	51

Twin Pipe Systems

HP/Model	½ HP - JRD5					
Jet Assembly Package (1)	FT3-09	FT4-13	FT4-31	FT4-08	FT5-14	
Well Casing Min. I.D. (in.)	3	4			4½	
Pressure	¾		1		1¼	
Suction PIPE SIZE (IN.)	1		1¼		1½	
Jet Body (only)	AT3		AT4		AT5	
Nozzle	AN015	AN017	AN016	AN015	AN018	
Venturi	AD722	AD726	AD723	AD720	AD724	
Control Valve Setting (PSI)	30					
Depth to Jet Assembly (Based on Submergence of 5')	Feet	Gallons Per Minute (GPM) 30-50 PSI Pressure Switch Setting				
	30	6.4	11.7	10.0		
	40	5.7	10.7	8.0		
	50	4.3	9.3	6.8		
	60			6.2	4.7	
	70			5.0	4.2	5.0
	80				3.3	4.3
	90				2.8	3.7

(1) Jet Assembly Package includes: Jet Body, Venturi, Nozzle, Foot Valve

Important Note: An offset of 50 feet will result in a decrease of about 25% from ratings as shown.

JRS5 PERFORMANCE CURVE (At 0' Suction Lift)

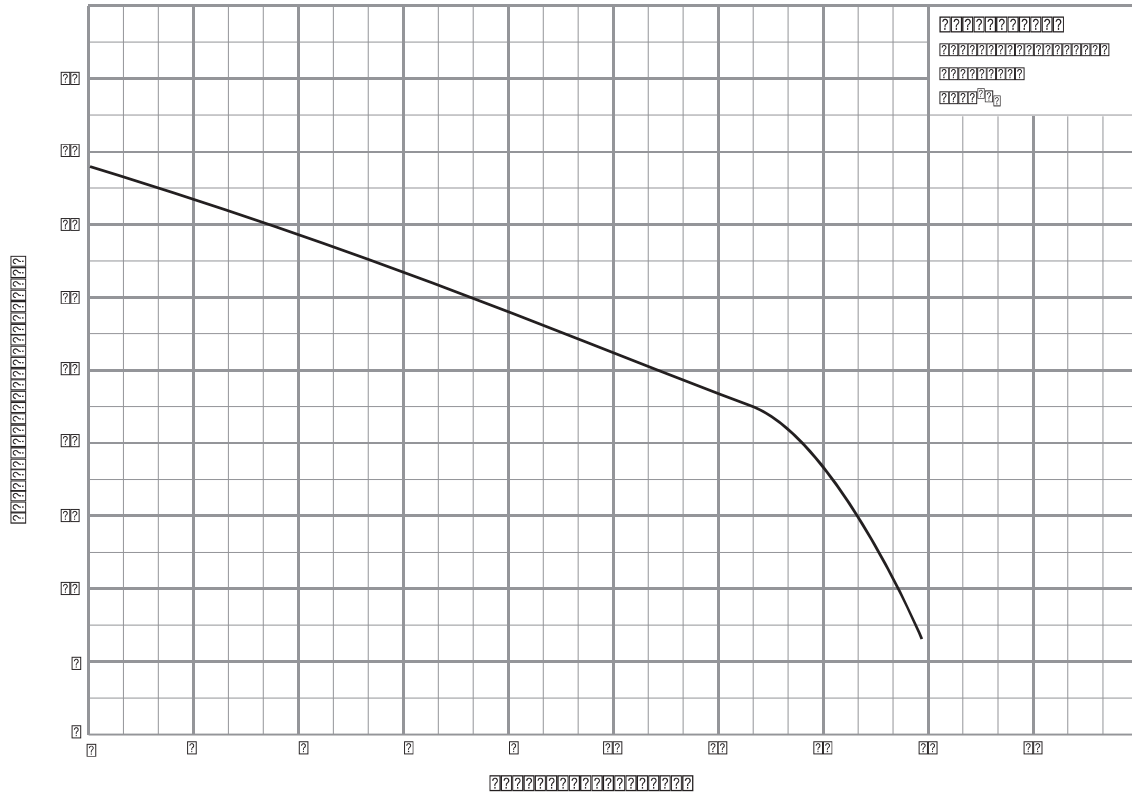

SYSTEM DIMENSIONS

Model	Tank	Tank Wt. (lb.)	Total Wt. (lb.)	①	②	③
JRD5X	V15P	12	43	17.5	2.5	15.6
JRS5X	V15P	12	43	18.5	3.5	16.7

Model	A (in.)	B (in.)	Tank	Tank Wt. (lb.)	Total Wt. (lb.)
JRD5K	32.5	25.5	V45PST	28	58
JRD5L	40.0	33.0	V60PST	40	70
JRS5K	33.0	24.5	V45PST	28	58
JRS5L	40.5	32.0	V60PST	40	70

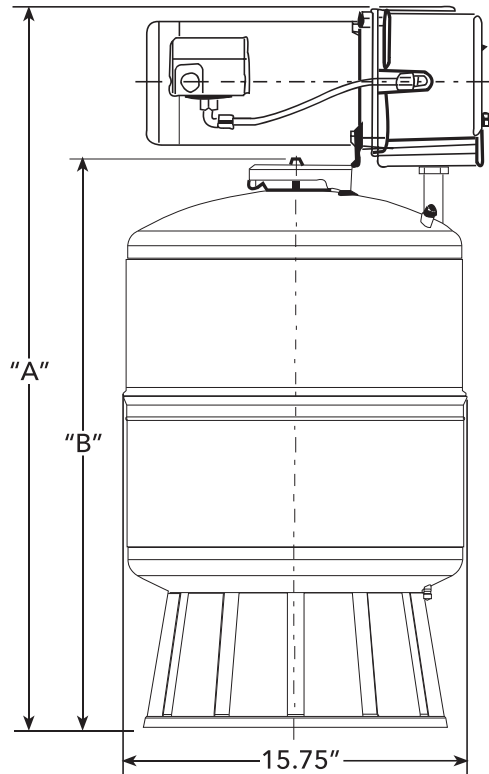
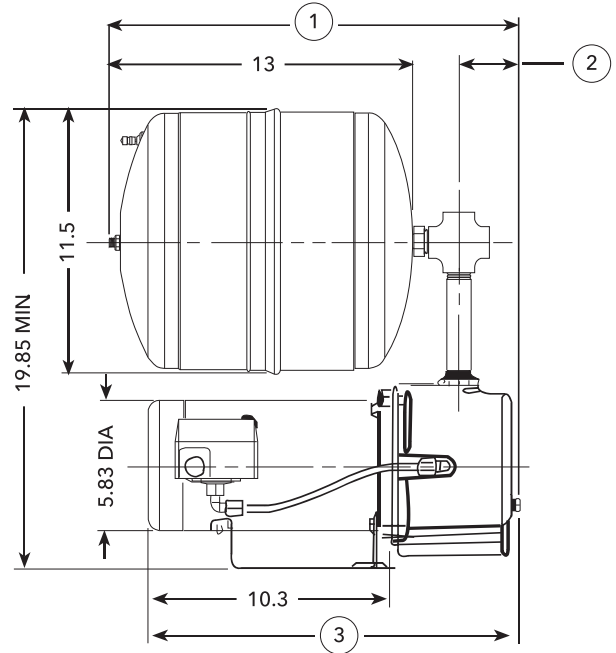

xylem
Let's Solve Water

Xylem Inc.
2881 East Bayard Street Ext., Suite A
Seneca Falls, NY 13148
Phone: (866) 325-4210
Fax: (888) 322-5877
www.xylem.com/goulds

Goulds is a registered trademark of Goulds Pumps, Inc. and is used under license.
© 2021 Xylem Inc. BJRPKG R2 March 2021