



Elevator Sump Pump Kits

OIL SMART - Staying dry and protecting the environment



The Oil Smart kits consist of panel, oil smart switch, liquid smart alarm sensor and pump. The setup allows water to be pumped from elevator sumps and transformer vaults without danger of pumping oil into sewers and waterways.

FEATURES

- Protects environment from hazardous waste
- The solid state device senses between oil and water
- Panel and switch kitted with sump/effluent 115V single phase pumps.
- Only operates pump if water is sensed by probes. Does not operate if oil is sensed by probes.

FEATURES FOR PUMP

- 1/3, 1/2, 115V, single phase pump
- Hard faced seal

ELEVATOR PUMP KITS

Brands	Model Number	Panel	Oil Smart Switch	Liquid Smart Sensor	Pump
GWT	ELKTGSP0311M	A1SEE1 Included	Included	Included	GSP0311M
	ELKTGSP0311M-25				GSP0311M-25
	ELKTGSP0511M				GSP0511M

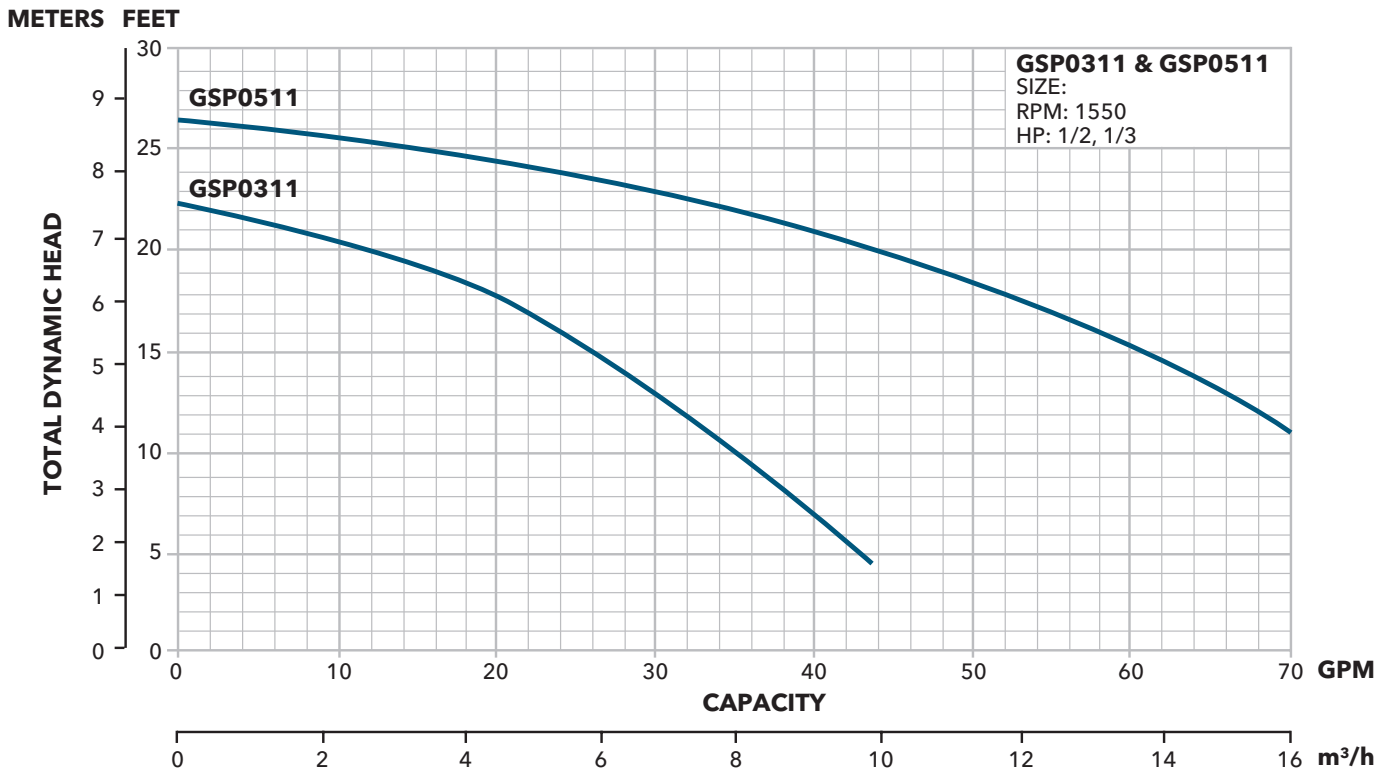

PANEL LAYOUTS

SIMPLEX SINGLE PHASE PANEL – A1SEE1

Enclosure Dimensions (in inches)

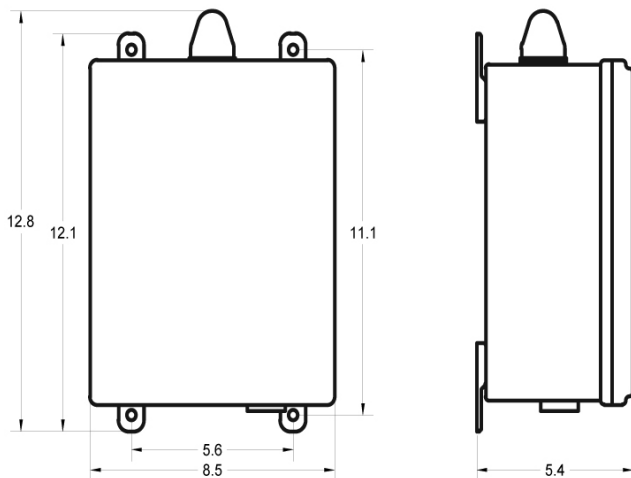

Wiring Diagram

INSIDE VIEW

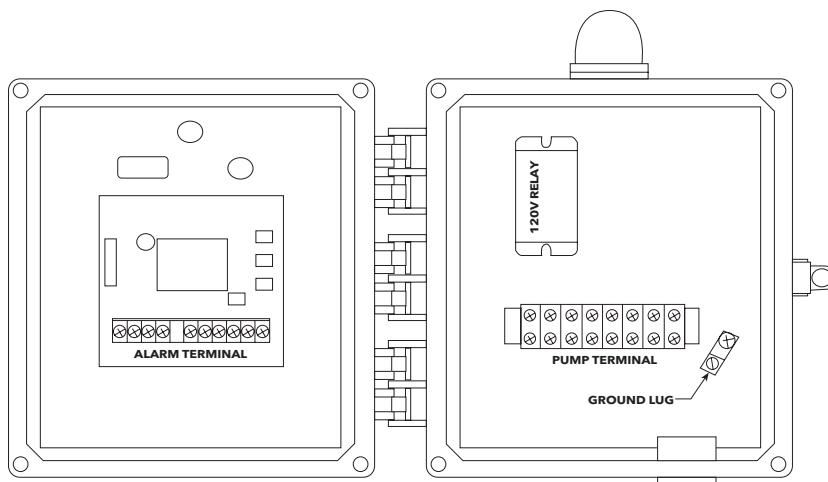

ALARM TERMINAL

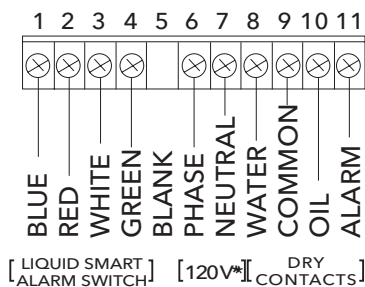

* Hook up separate 120V supply here or jump from pump terminal 1 and 3 to alarm terminal 6 and 7 for power.

PUMP TERMINAL

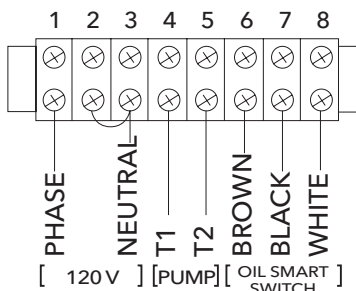

* For 240V, remove jumper and supply power to terminals 1 and 2, with neutral on 3.



Xylem |'zīləm|

- 1) The tissue in plants that brings water upward from the roots;
- 2) a leading global water technology company.

We're a global team unified in a common purpose: creating advanced technology solutions to the world's water challenges. Developing new technologies that will improve the way water is used, conserved, and re-used in the future is central to our work. Our products and services move, treat, analyze, monitor and return water to the environment, in public utility, industrial, residential and commercial building services settings. Xylem also provides a leading portfolio of smart metering, network technologies and advanced analytics solutions for water, electric and gas utilities. In more than 150 countries, we have strong, long-standing relationships with customers who know us for our powerful combination of leading product brands and applications expertise with a strong focus on developing comprehensive, sustainable solutions.

For more information on how Xylem can help you, go to www.xylem.com

Learn more about
Sump Pumps

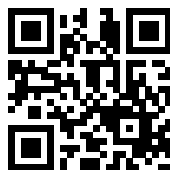

Xylem Inc.
2881 East Bayard Street Ext., Suite A
Seneca Falls, NY 13148
Phone: (866) 325-4210
Fax: (888) 322-5877
www.xylem.com/goulds

Xylem is a registered trademark of Xylem Inc. or one of its subsidiaries. Goulds is a registered trademark of ITT Manufacturing Enterprises LLC and is used under license. All other trademarks or registered trademarks are property of their respective owners.
© 2023 Xylem Inc. GSP01LSSALES R2 April 2023