

# AQUAFORCE e-HV™

VARIABLE SPEED BOOSTERS WITH  
VERTICAL MULTISTAGE e-SV PUMPS 60 HZ



# Table of Content

General Introduction .....	3
Major System Components .....	4
Operating Conditions .....	4
Typical Arrangements .....	4
Hydraulic Performance Range .....	5
Typical Construction .....	6-7
Operation Description .....	8-11
Booster Selection .....	12
Pump Selection .....	13-15
3SV Curves/Dimensions .....	16-23
5SV Curves/Dimensions .....	24-31
10SV Curves/Dimensions .....	32-39
15SV Curves/Dimensions .....	40-47
33SV Curves/Dimensions .....	48-55
Product Key .....	56

# General Introduction - Product Description

The e-HV pump systems are pre-engineered and fabricated packaged booster systems designed to transfer and increase the pressure of clean water. The e-HV provides pressure boosting for a variety of applications:

- Commercial Office Buildings
- Industrial/Plant
- Hospitals
- Schools
- Hotels, Inns & Resorts
- Condominiums & Apartments
- Sports Facilities
- Data Centers
- HVAC
- Irrigation
- Main Water Systems
- Rural Boosting Stations

The e-HV booster sets are assembled with two to four vertical multistage e-SV pumps fixed onto a single base and connected in parallel via suction and discharge manifolds and fittings. The station is provided with a main system disconnect as well as individual electrical pump isolation to ensure that each pump can be serviced without the need to shut down the entire station.

## Hydrovar® Multi-Master Drive/Controllers

As a standard every e-HV booster is offered in the Multi-Master configuration. This means that each pump is paired with our Hydrovar master type VFD mounted directly to a standard TEFC Premium Efficient NEMA Frame motor. Variable speed operation is handled via the designated “lead” master VFD in the given e-HV configuration. In the event of a failure in the lead master VFD, any of the sub sequential masters will become the lead and take control of the station. This gives the end user complete redundancy and increases the reliability of the system.

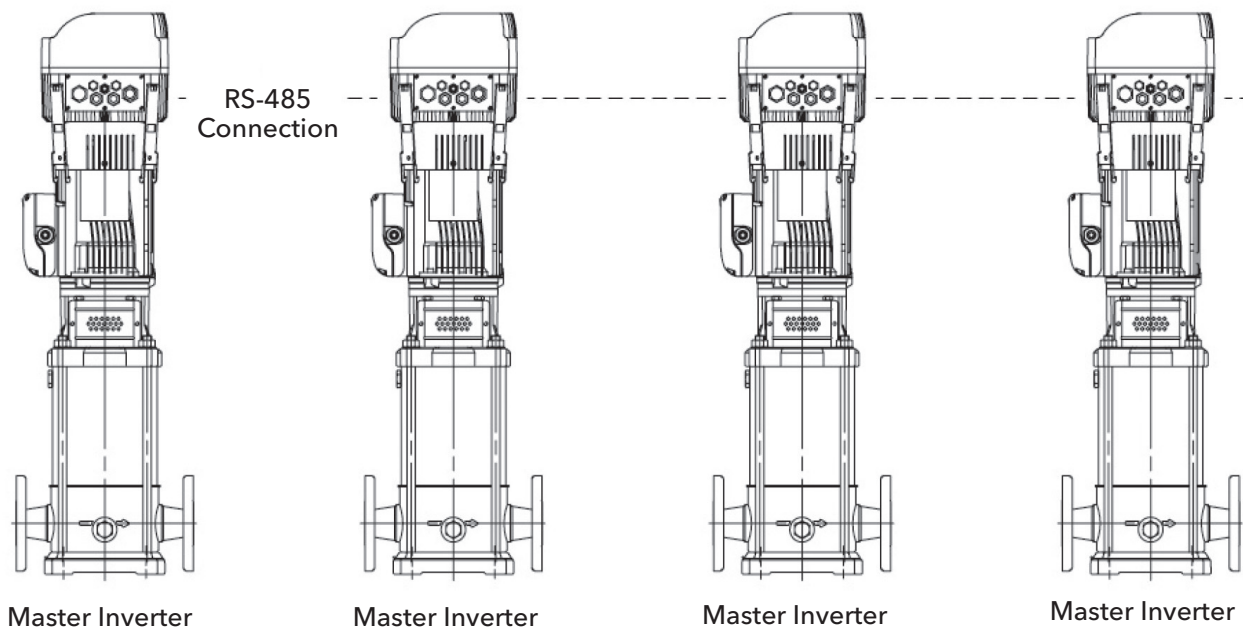

# Major System Components

- Number of Pumps:** 2 to 4
- Motor Power (HP):** 1.5 - 15
- Base:** 304SS reinforced, formed
- Frame:** 304SS
- Manifolds:** 304SS Sch. 10 with Grooved connections
- Isolation:** Less than 2 inch - Ball  
Greater than 2 inch - Butterfly
- Check:** Less than 2 inch - Silent  
Greater than 2 inch - Wafer
- Pump:** e-SV vertical multistage
- Motor:** TEFC Premium Efficient NEMA C-Face
- VFD:** Hydrovar® Master Pump Control/Drive UL Type 1 / IP 55
- Panel:** NEMA 12 with integrated system and pump disconnects
- Communication:** RS-485

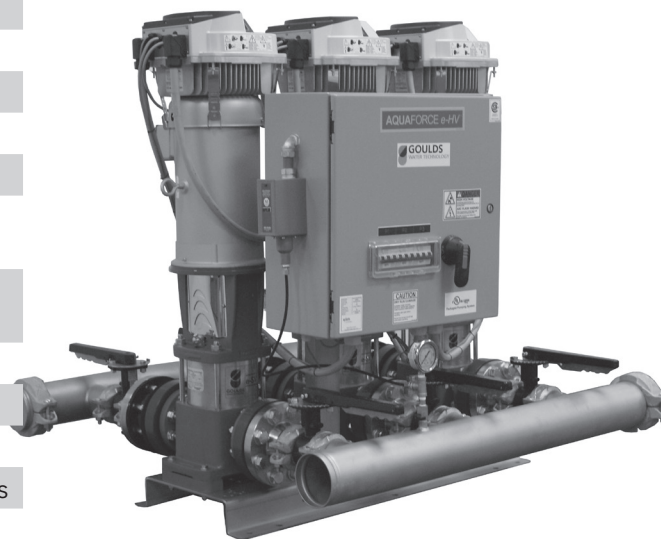

# Operating Conditions

- Fluids:** Water containing now gas or corrosive and/or aggressive substances, no undissolved solids
- Flow Rate:** Up to 780GPM
- Operating Pressure:** Up to 270 PSIG
- Liquid Temperature:** 32°F to 180°F
- Ambient Temperature:** 32°F to 104°F, avoid direct sunlight
- Relative Humidity:** 90% non-condensing
- Elevation:** 3300 ft above sea level without derate

\*On special request B&G can offer higher flow, pressure and Typic temperature rated packages.

# Typical Arrangements

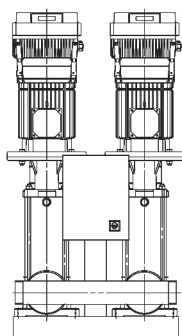

**Duplex**

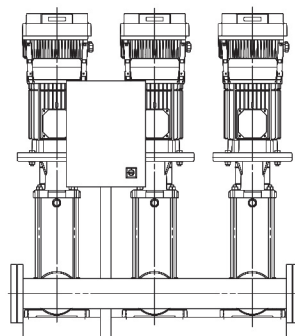

**Tripex**

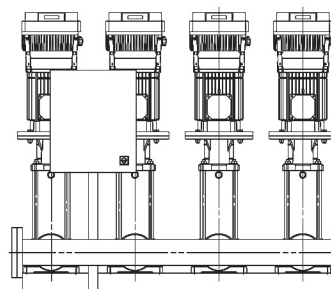

**Quadplex**

# Hydraulic Performance Range

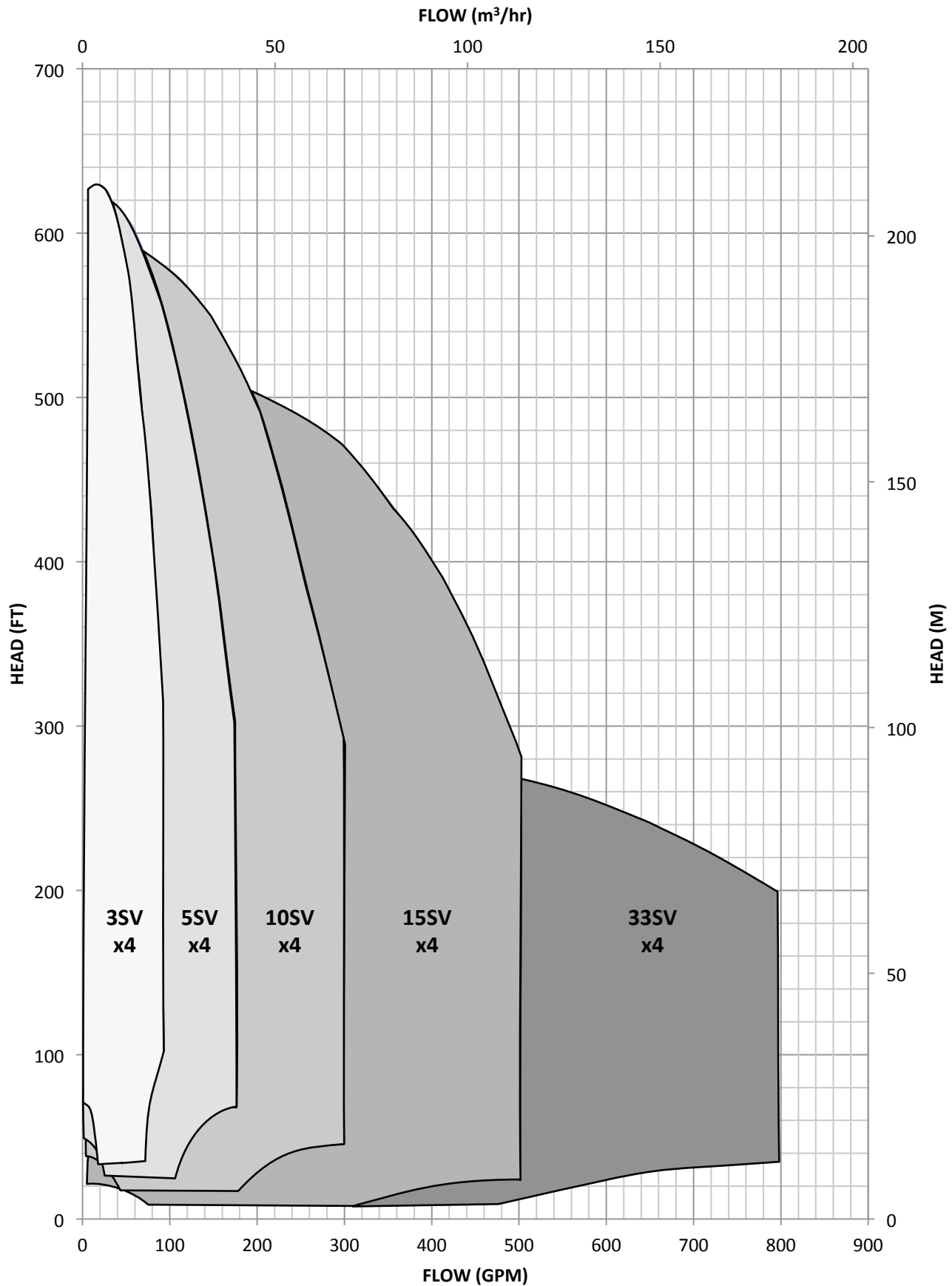

# Typical Construction

## PUMP

The e-SV pump is a non-self-priming vertical multistage pump coupled to a standard motor. The liquid end, located between the upper cover and the pump casing, is held in place by tie rods. This design allows for the removal of the mechanical seal without the need to remove the motor from the pump. The pump casing is available with different configurations and connection types.

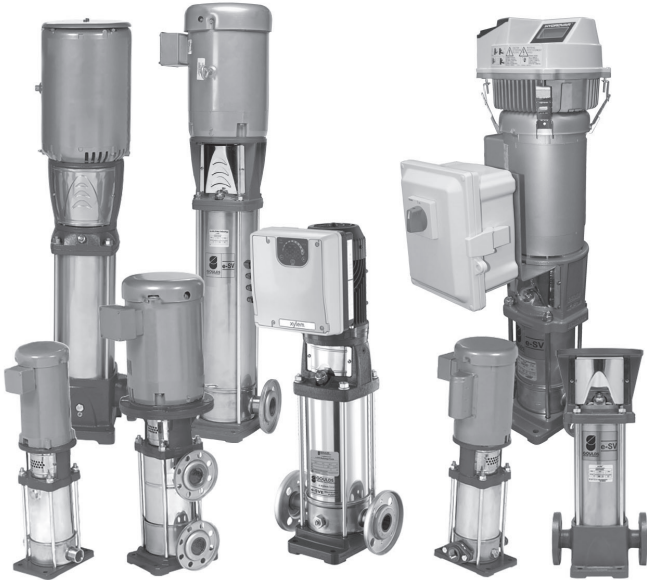

## TECHNICAL INFORMATION

**Available Models:** 3SV, 5SV, 10SV, 15SV, 33SV

**Flow Rates:** up to 200 GPM.

**Heads: (TDH):** up to 620 feet

**Power:** 1.5 to 15HP

**Max Operating Pressure:**

SV1-22 with round flanges: 360 or 575 PSI (25 or 40 bar)

SV33, 360 or 580 PSI (25 or 40 bar)

**Temperature of Pumped Liquid:**

22°F to 250°F standard design

22°F to 300°F Hot water design

Clockwise direction of rotation looking at the pump from above (indicated with an arrow on the bracket and joint).

For more information please refer to e-SV Technical Manual BeSV60

## MOTOR

The e-SV pump utilizes standard NEMA C-face motors. The e-HV comes standard with TEFC Premium Efficient 2-pole motors. For more information please refer to station submittal documentation.

## STATION DISCONNECT ENCLOSURE

A NEMA 12 rated enclosure is fitted with all the necessary components required to provide power to the station via a single field provided electrical connection. Each station will be provided with a main station disconnect and individual pump circuit breakers accessible without the need to disengage the main station disconnect.

# Pump Control

The e-HV utilizes master Hydrovar variable frequency drives (VFD) that adjusts the speed of the pump in order to maintain constant pressure in the system. The Hydrovar comes standard with a UL type 1 / IP55 rating and is mounted directly on to the TEPE motor via mechanical brackets.

Pressure is measured via a 4-20mA pressure transmitter which can be read on the Hydrovar's display. A simple user interface allows you to set the desired pressure value for optimal adjustment, as well as view the operating data, such as the hours of operation and any alarms triggered.

Included diagnostic menu to view temperature, current and voltage values of Hydrovar facilitates diagnostics and failure analysis. Indicator lights signal power status, pump running and malfunctions. A password is required to access sensitive settings such as flow resistance compensation, external control and so on that allow you to configure the pump logic control in order to adapt it to any control requirements.

When more than one pump is used, the vfd's exchange information with each other through an RS485 serial line which can connect up to 8 Hydrovar devices plus one external unit for remote control. RS485 serial interface available as standard which allows to control the Hydrovar converters from a Modbus® field serial bus line.

Each VFD is equipped with two potential-free relays which can be used for remote signaling of pump running and malfunction status, plus a programmable voltage analog output for signaling the frequency or pressure. Standard version with two sensors inputs for implementing of two actual values signals within one system (min/max, difference) or for a second sensor for safety reasons. Specific digital inputs are used for protection against water failure, motor over temperature, as well as for external enable signal and remote control. The vfd also incorporates a dry running protection function via an adjustable minimum pressure threshold.

As added protection designed to protect the pump, motor and pumping system, the Hydrovar operating system shall also detect the following fault conditions: under voltage, motor overload, short circuit, ground fault, motor over-heat (with thermistor), low suction pressure, and pump run-out.

A Class A filter is standard for Hydrovar three-phase power supply.

The following programmable flow 'Run/Standby' splits are available for pump control:

- 100 + Stdby
- 50/50
- 50/50 + Stdby
- 33/33/33
- 33/33/33 + Stdby
- 25/25/25/25

Further information is available into Hydrovar manual IM289 and Cod. 001085102 rev. A.



# Sequence of Operation

The e-HV multi-pump booster control system operates up to 4 equal pumps. Each pump is outfitted with a Hydrovar combination variable speed Master drive via a RS-485 interface. Each drive/controller is fitted with a dedicated 4-20mA pressure transducer located on the discharge manifold. As flow demand increases, the pump speed shall be increased to maintain the system set-point pressure.

The e-HV booster maintains a constant system setpoint pressure as shown in the following example:

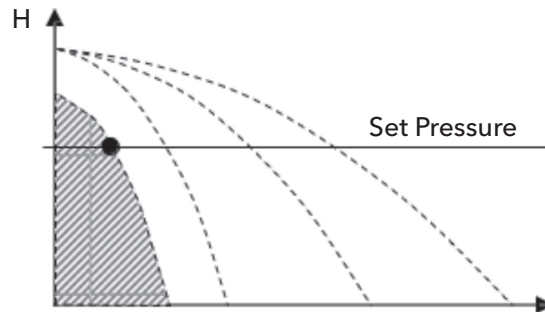

When the lead pump drive/controller reaches 48 Hz, and a pressure drop of 2 PSI below the set-point is detected for a minimum of 5 seconds, additional pump(s) will start as needed and will increase speed until the system set point is achieved (note: control value parameters are adjustable).

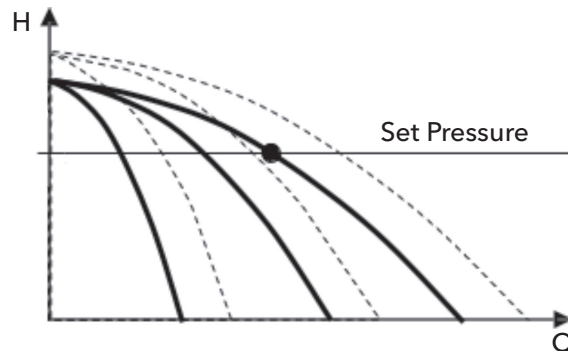

When the demand decreases, pump speed is reduced until the minimum speed is reached, and pumps switch off in Cascade Serial mode. for a condition of 'no-flow', the booster control system will shut down until a programed minimum pressure set point is detected, signaling the control system to restart the lead pump. Cascade Serial control mode shall alternate the pumps automatically every 24 hrs for balanced usage, wear and tear.



# Operation Description

## SETPOINT

It is possible to select up to two set points of different values, thus use the booster set to serve systems that require different user pressure values. For example, different set points can be used for different times of the day when the load conditions may vary greatly in an office build or school. The set point changes can set when the Booster is installed and are adjustable via the RS-485 communication through the BMS. It is also possible to change the measuring units to bar, psi, m<sup>3</sup>/h, °C, °F, l/sec, l/min, %. In this case it is possible to use different transducers depending of the selected measuring unit, such as flow and temperature transducers.

## PUMP ALTERNATION

Alteration of the pumps can be set at the start at every system restart or at a given time set for each pump by means of an internal clock in the drive menu. This will help ensure equal amounts of run time for the available pumps on the station.

## PROTECTION AGAINST DRY RUN

The protection function against dry running intervenes if the water reserve to which the booster set is connected falls below the minimum level guaranteed for suction. For the e-HV the level may be controlled by a float, level probes or minimum pressure switch. It is also possible to manage the function directly by imputing a minimum pressure value in the Hydrovar control board menu, which will receive a signal from the pressure transducer

## VARIABLE SPEED PERFORMANCE

By outfitting the pump with a variable frequency drive it becomes possible to vary the pump rotation speed according to a system pressure. These variations in speed with result in modified performance characteristics according to the relationships established by the Affinity Laws.

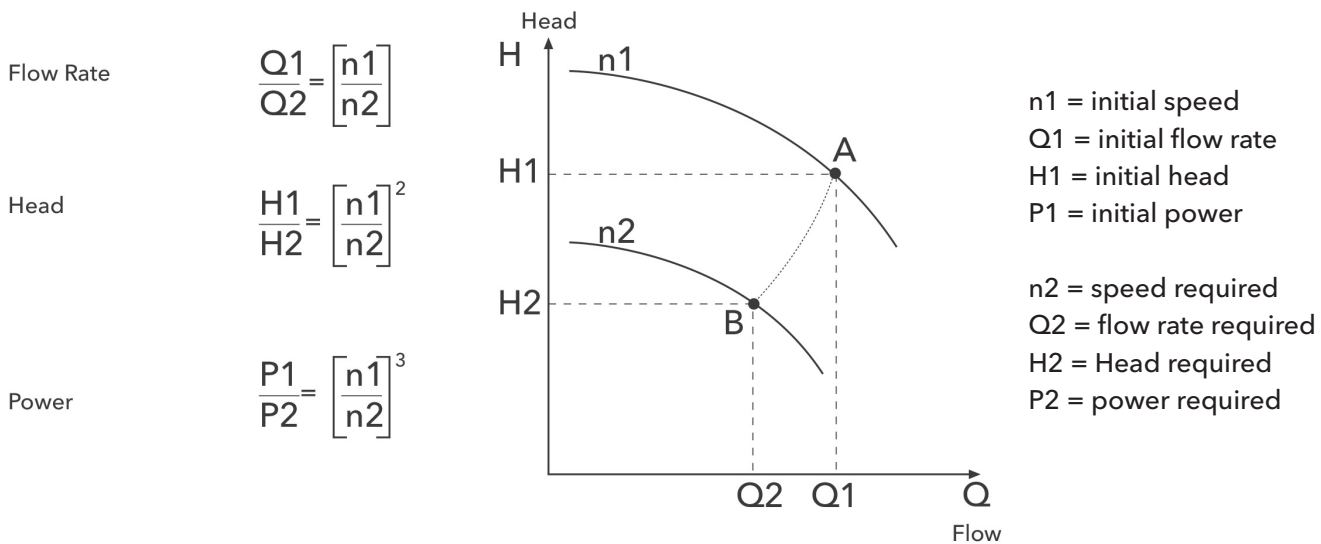

### Example:

2-pole, 60Hz, electric pump; n1 = 3500 RPM (point A); P1= 20HP

Flow Rate (A) = 150 GPM; Head (A) = 300 ft

By reducing the frequency to 50Hz the is reduced to approx. n2 = 2500 RPM (point B)

Flow Rate (B) = 107 GPM; Head (B) = 153 ft

The required power of the new work point B is now 7.29 HP

# Booster Selection

The following conditions should be considered when choosing a booster set:

- Design Point
- Part Load Conditions
- Efficiency
- NPSH (Suction Conditions)
- Standby pumps
- Diaphragm tanks

## CALCULATING THE FLOW RATE

The quantity of water called the **water requirement** depends on the type of application, e.g. office, school, hospital. The **value of peak consumption or design point** is the total amount of water required by all of the users at a given time period. In actual fact it is very unlikely that there will ever be a simultaneous demand by all the users so the **part load conditions** will be lower than the value of peak consumption and should be taken into account when selecting your package. Understanding these part load conditions could impact the size and number of pumps you select to optimize the efficiency of the system

## CALCULATING THE HEAD

The pressure required for a given system will depend greatly on the application. A number of factors must be taken into account, including the **height of the building, resistance in the pipes and suction conditions.**

For help calculating pipe resistance download the B&G System Syzer: <http://bellgossett.com/selection-sizing-cad-tools/system-syzer>

## NPSHr

The **Net Positive Suction Head Required** is the net suction head as required by the pump in order to prevent cavitation for safe and reliable operation of the pump. These values are displayed on the pump curves.

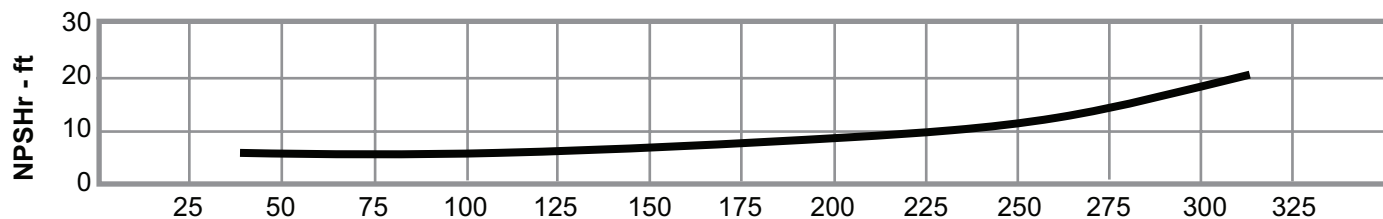

## NPSHa

The **Net Positive Suction Head Available** is the absolute total suction head available at the pump suction. The application will dictate this value and a few other conditions must be taken into consideration:

ha = Absolute Pressure on the surface of the liquid supply level in feet. (Barometric for open tank)

h<sub>vpa</sub> = The head in feet corresponding to the vapor pressure of the liquid at pumping temperature

h<sub>st</sub> = static height in feet of the liquid supply level above or below the pump centerline

h<sub>fs</sub> = All suction line losses in feet.

# Booster Selection

## SUCTION CONDITIONS

Understanding the suction conditions for a given application is very important when selecting a Booster. Without the proper **NPSHa (Net Positive Suction Head Available)** the Booster may not be able to deliver proper conditions to the system and the pumps will likely cavitate if not higher than the **NPSHr (Net Positive Suction Head Required)**. If more suction pressure is available than the system was designed for the system may be prone to short-cycling or simply not operate at all.

### NPSHa > NPSHr

In general there are **three types** of suction conditions to consider when selecting your booster station:

#### 1. Pressurized

Installation where the supply is coming from a pressurized source. Typically this is a municipal water line with backflow preventer

#### NPSHa = Suction Pressure

Available Boost =  
 Station discharge pressure  
 - Station suction pressure  
 + Station friction losses

\* Note: Suction pressure should be calculated at full flow to get accurate DP across the backflow preventer.

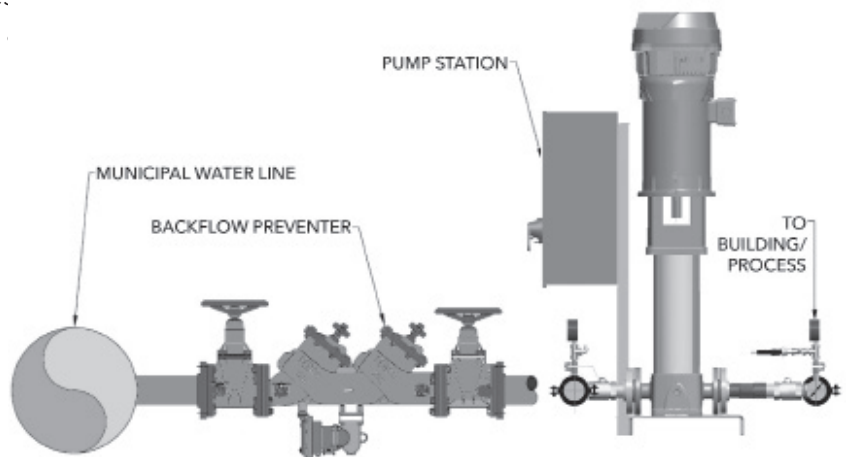

#### 2. Flooded

Installation where the supply is from an above ground tank or water source where the water level is higher than the pump centerline.

#### NPSHa = $h_a - h_{vpa} - h_{st} - h_{fs}$

Available Boost =  
 Station discharge pressure  
 - Station suction pressure  
 + Station friction losses

\* Note: Elevation can affect atmospheric pressure and temperature, vapor pressure. Please refer to the tables in Appendix.

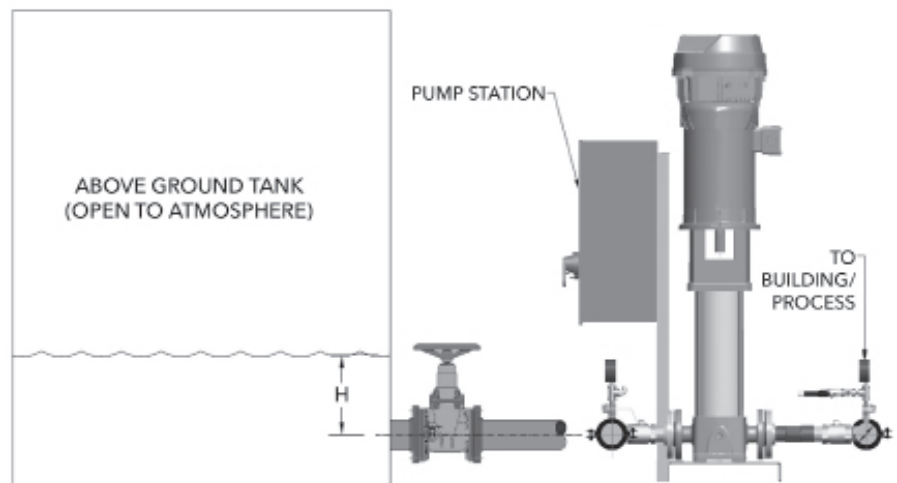

# Booster Selection

## 3. Lift

Installation where the supply is from a pond, lake or below ground tank where the water level is below the pump centerline.

$$NPSHa = ha - hvpa - hst + hfs$$

Available Boost =  
Station discharge pressure  
- Station suction pressure  
+ Station friction losses

\* Note: Lift applications typically require special design considerations. Foot valves and/or dedicated suction valves may be required. Please Consult Factory for Lift applications.

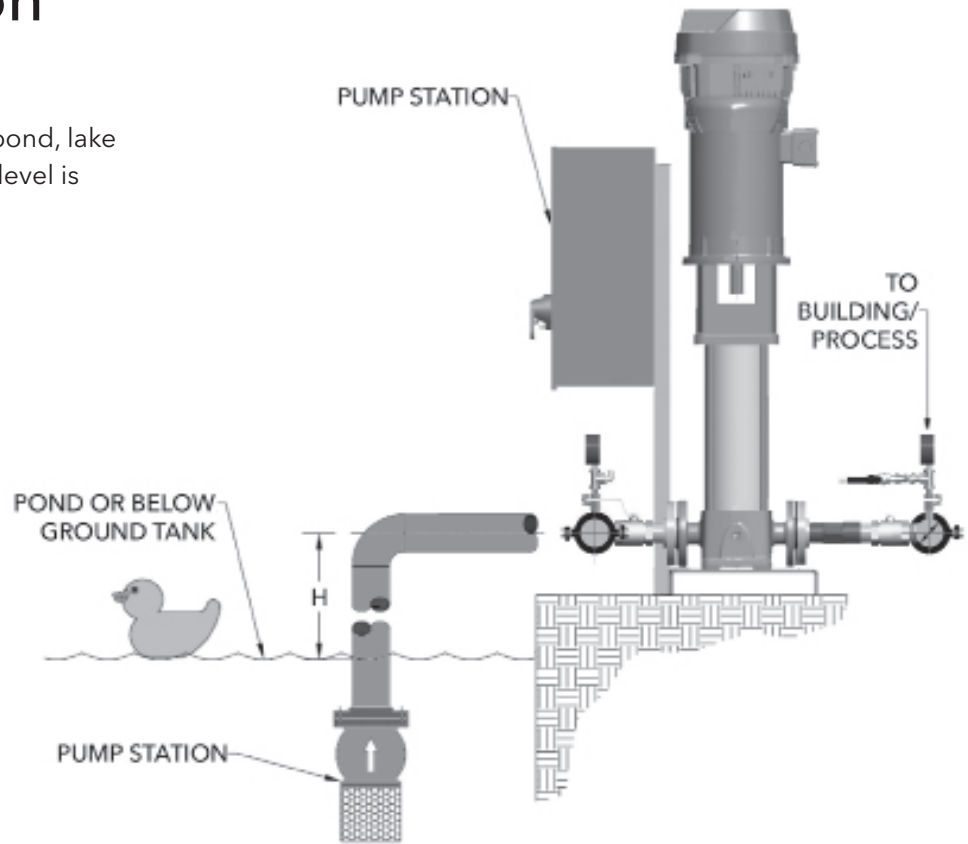

# Pump Selection

Now that we understand the factors that typically impact our Booster selection, sizing the proper pump is key. Ensuring the station can meet the design point but is also efficient at the part load conditions will provide the end user with the best possible solution. Utilizing the IntellitronicX selection software you can automatically understand the available e-SV pumps that can meet your system needs as well as complete Booster stations.

Visit: [gouldsintellitronic.com](http://gouldsintellitronic.com) to login or register.

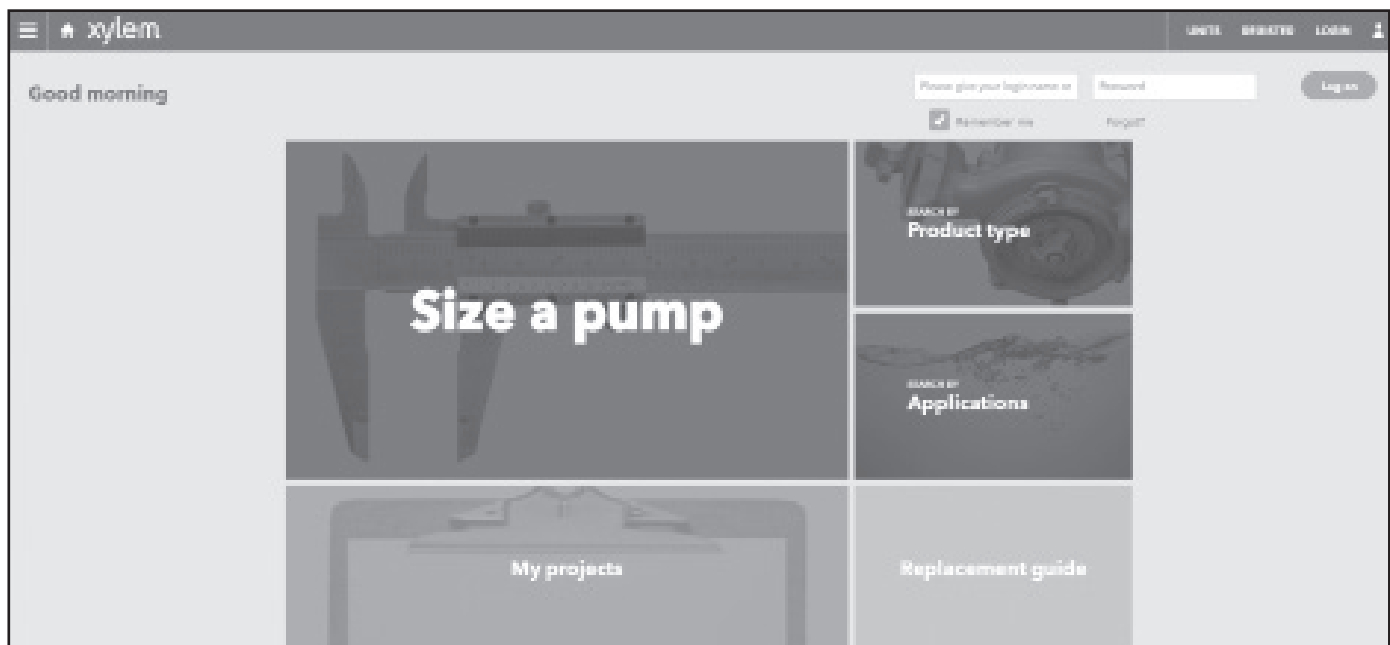

# Pump Selection

Using the online tool we are able to sort pump selections based on all of the above factors discussed in previous sections:

After entering our conditions we are given the available pumps sorted by efficiency.

4 results		FLOW: 195 US g.p.m.	HEAD: 145 ft	DISPLAY CURVE: OFF						
		STATIC HEAD: 0 ft	PIPE SYSTEM: No							
	SCREENS	PRODUCT	DESIGN	N (gpm)	D2 (in)	Q (US g.p.m.)	H (ft)	P2 * NO... (hp)	η (%)	RELAT... (%)
		AquaForce e-HV HVL2D3-155V9GHP40-2GD	Booster Package	3500	0	196.8	147.7	10.7	69.9	109
		AquaForce e-HV HVL2D3-335V23GHF40-2GD	Booster Package	3500	0	196.7	147.6	10.5	69.5	71.4
		AquaForce e-HV HVL2D3-335V21GHF60-2GD	Booster Package	3000	0	212.2	172.4	13.2	69.1	68.7
		AquaForce e-HV HVL2D3-155V4GHP40-2GD	Booster Package	3000	0	216.0	177.9	14.8	67.9	120

# Pump Selection

Pulling up the pump curve we can now evaluate pump selection for our application:

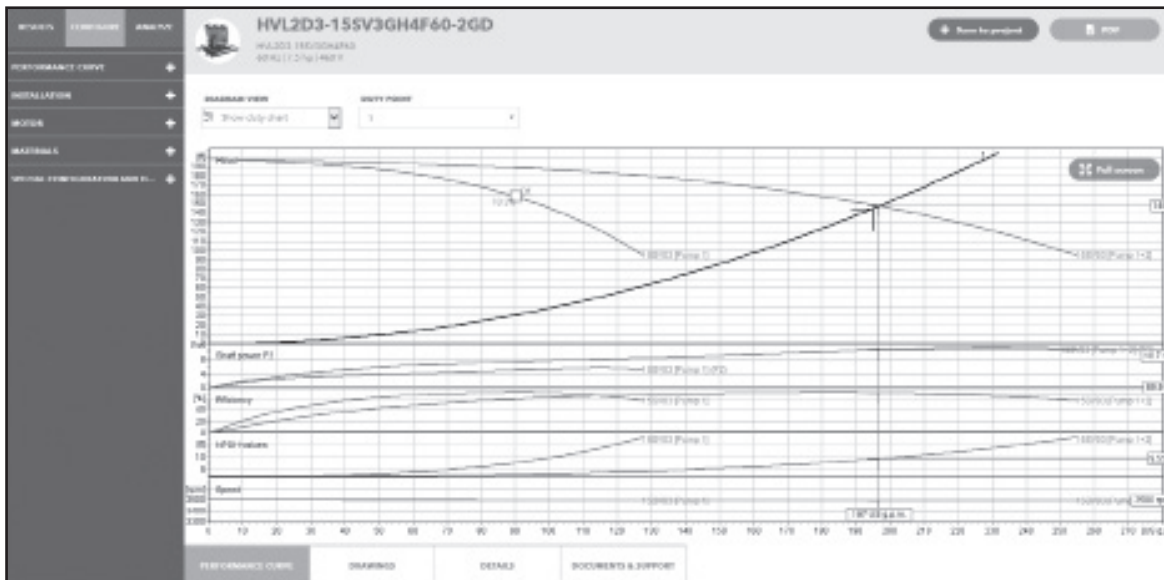
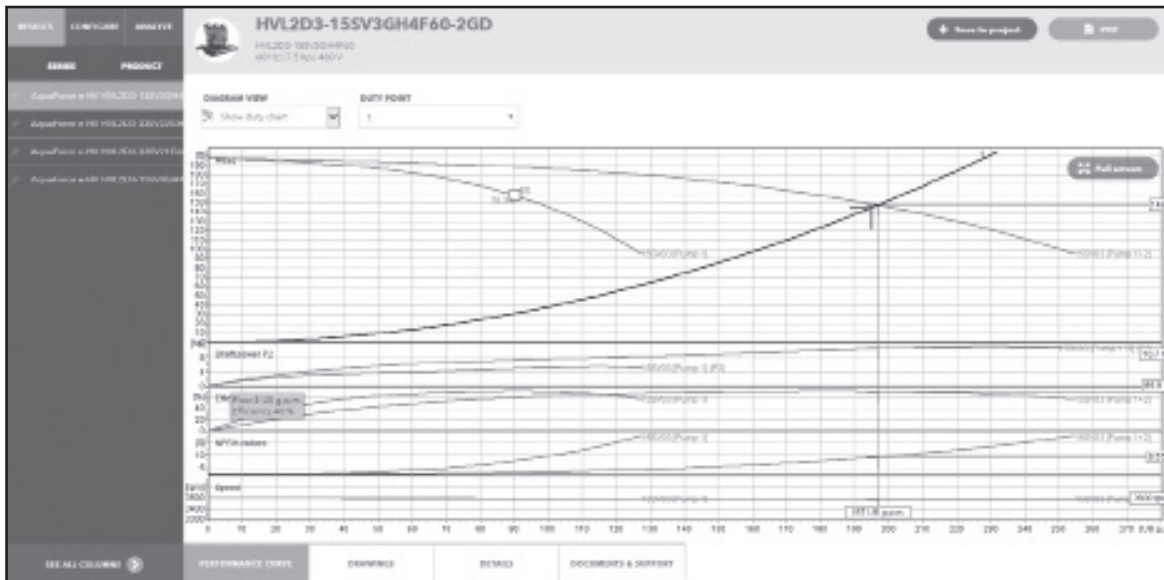

# Pump Selection

We can even see what multiple pumps in parallel will look like:

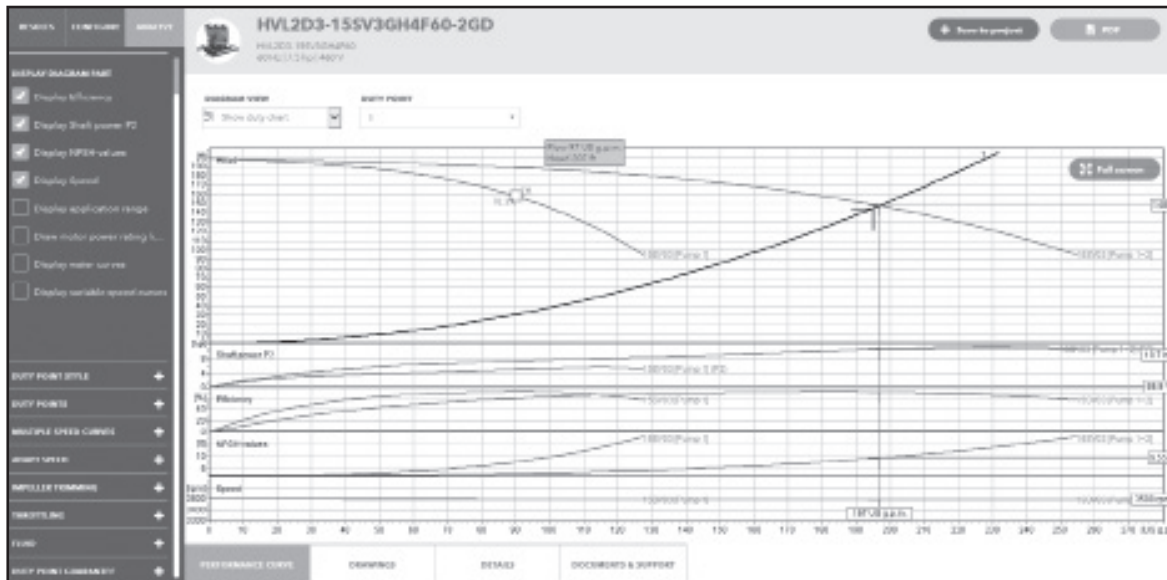

For the e-HV we have optimized the pump selection based on flow and head available for 1 to 4 pumps running in parallel. For standard offering and availability please see the Pump Curves section of this brochure or selection software available in the online tool.

## DIAPHRAGM TANKS

Frequent demand or small system losses determine pressure variations that may be compensated for by using a tank. Correct selection of a diaphragm tank reduces the number of pump starts and if it is installed near the booster set, helps reduce the effect of water hammer or fast acting flush valves.

The e-HV booster sets are ready for installation of the diaphragm tanks directly on the delivery manifold or on the unused end of the manifold.

For peak performance, variable speed booster sets need smaller tanks compared to traditional systems. Generally speaking a tank with a capacity of just 20% the nominal capacity of a single pump, expressed in gallon per minute, is required. Example: If a pump is sized for 100GPM, then a tank sized at 20 Gallons would be typical.

Pre-charge the tank with air, 10-15 psi below your system pressure. Charge a dry tank without water pressure or before installing in the system.

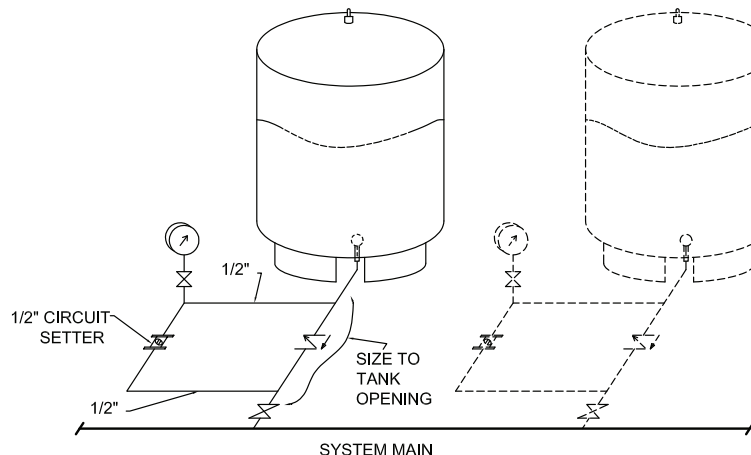

- 1) IF MULTIPLE TANKS ARE INSTALLED, ALL MUST BE PIPED AND PRE-CHARGED THE SAME.
- 2) PIPING ARRANGEMENT SHOWN RECOMMENDED WITH "NO-FLOW SHUT DOWN" SYSTEMS.
- 3) ADJUST CIRCUIT SETTER TO LIMIT TANK CHARGING RATE TO LESS THAN LEAD PUMP'S DESIGN FLOW RATE.
- 4) FAILURE TO RESTRICT FLOW MAY CAUSE SECOND PUMP TO STAGE UNNECESSARILY DURING CHARGING CYCLE.

# AquaForce e-HV Curves 3SV

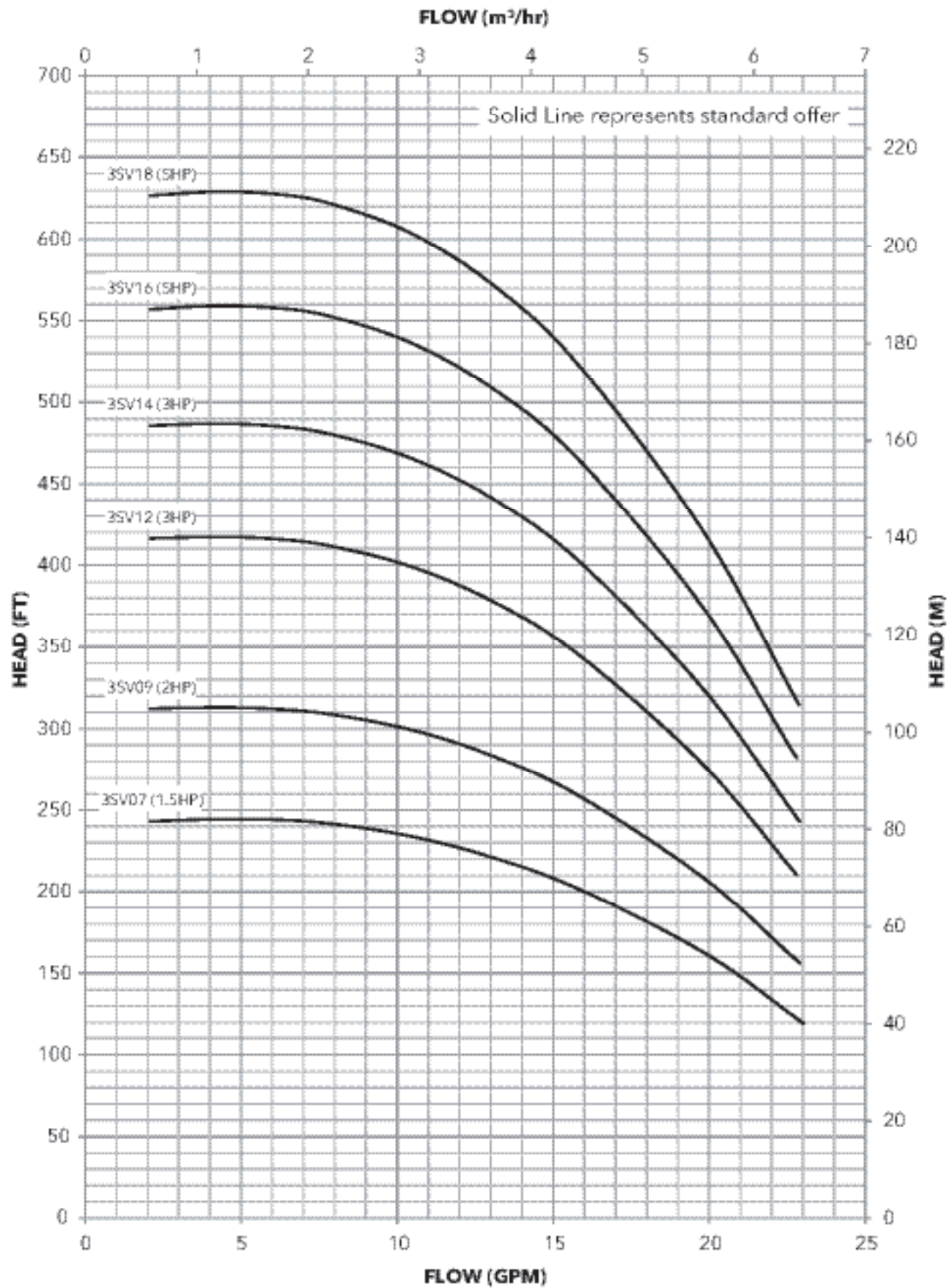



# AquaForce e-HV Curves 3SV

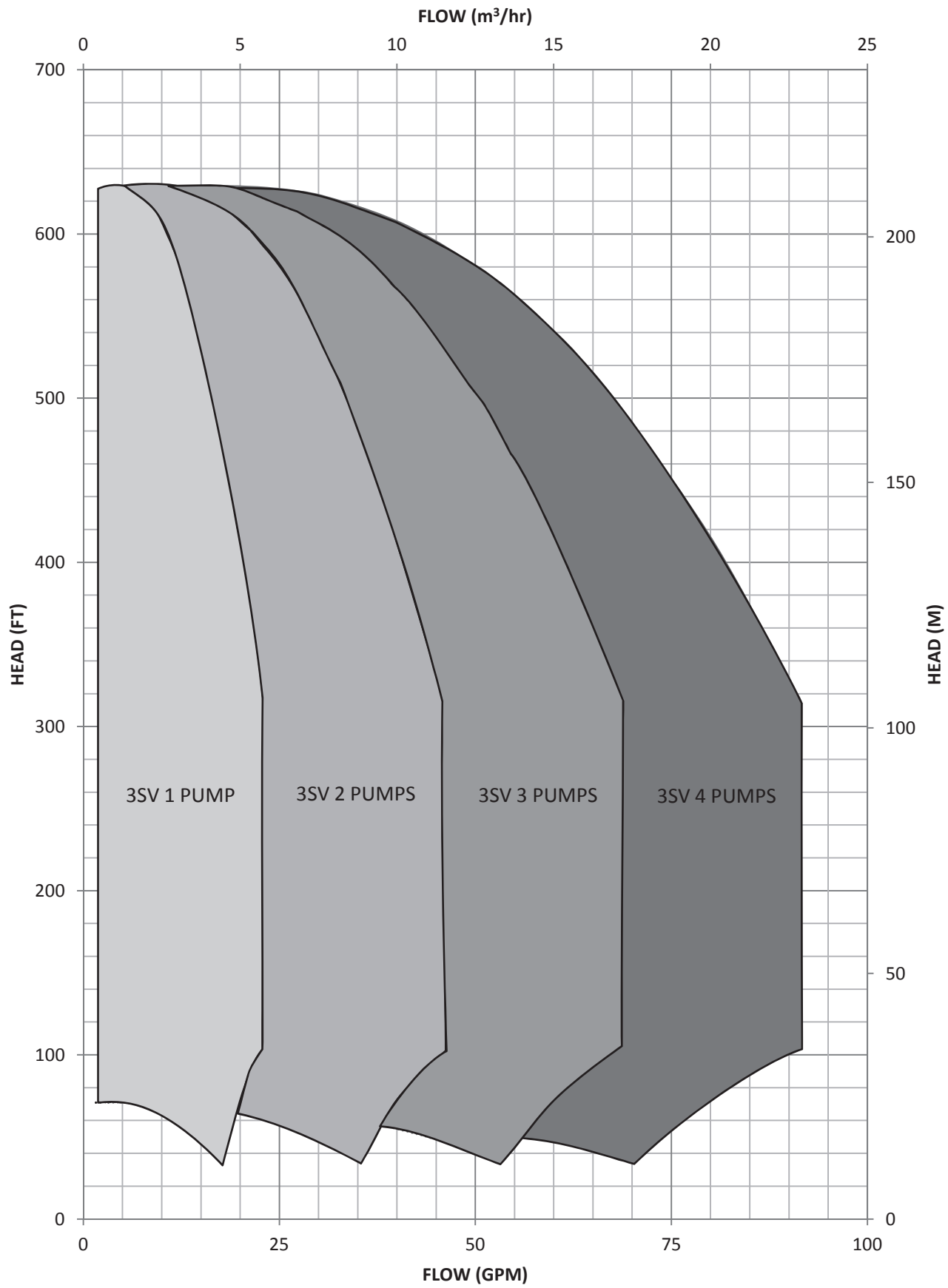

208-230V  
AquaForce e-HV Dimensions 3SV - 2 Pump

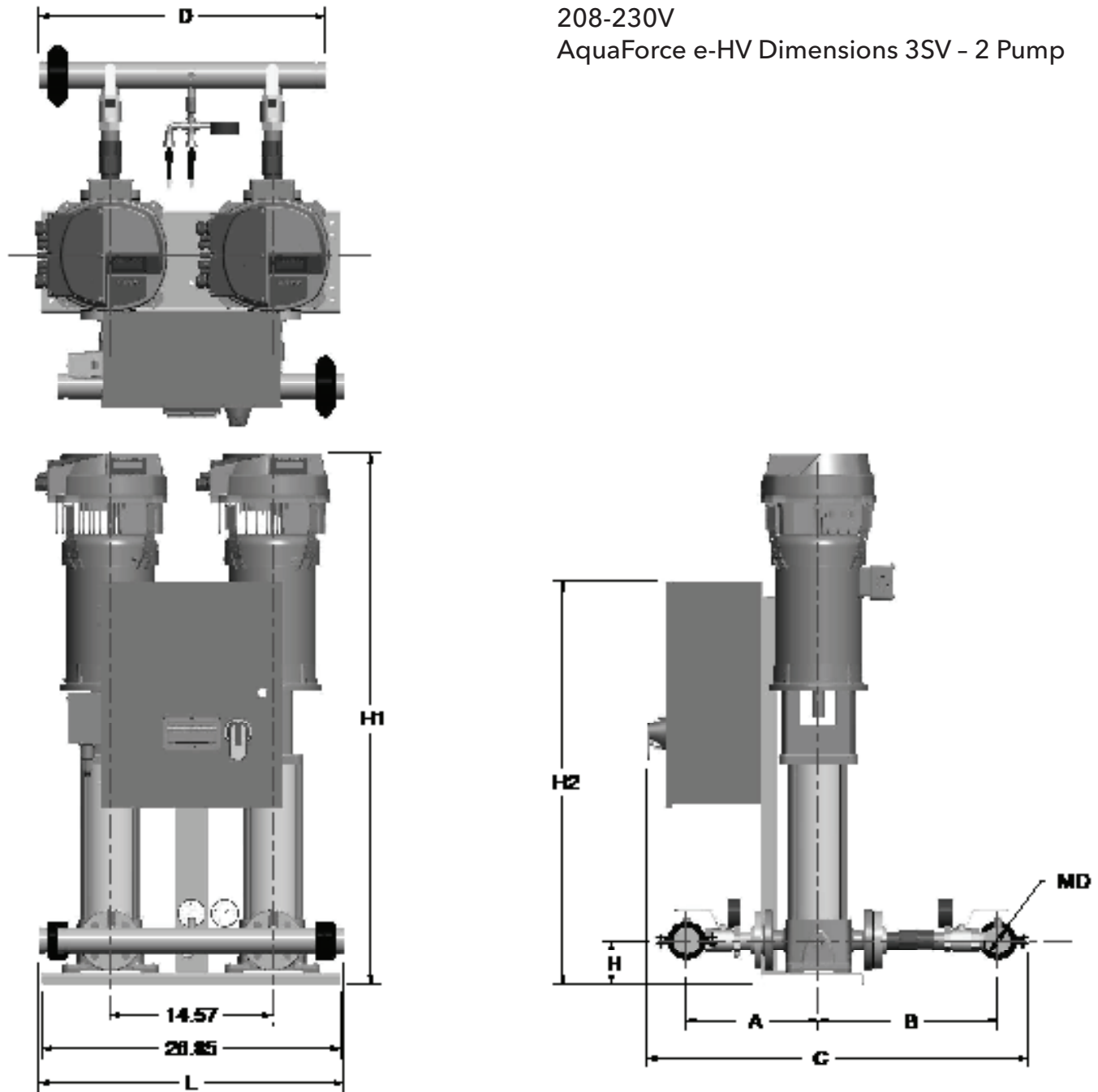

HVL2L2	MD	A	B	C	D	H	H1	H2	L	Wt. (lb)
36V7GD4F80	2	11.83	18.00	34.23	25.87	4.04	25.28	21.27	27.23	221.0
36V0GE4F80	2	11.83	18.00	34.23	25.87	4.04	28.84	21.27	27.23	240.2
36V12GF4F80	2	11.83	18.00	34.23	25.87	4.04	41.81	21.27	27.23	285.4
36V14GF4F80	2	11.83	18.00	34.23	25.87	4.04	42.28	21.27	27.23	400.0
36V16GG4C80	2	11.83	18.00	34.23	25.87	4.04	47.06	28.27	27.23	502.5
36V18GG4F80	2	11.83	18.00	34.23	25.87	4.04	49.22	28.27	27.23	512.7

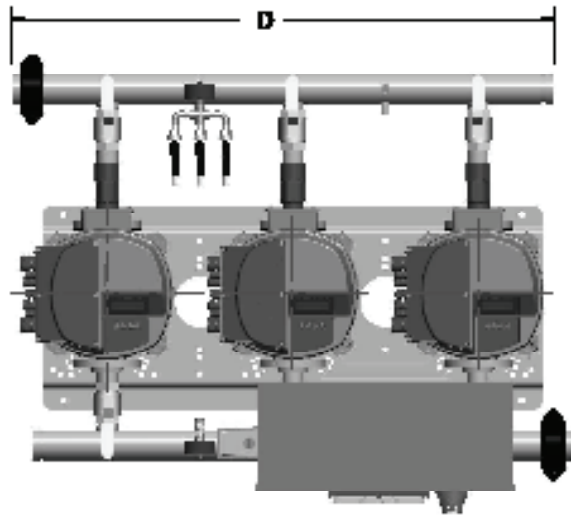

208-230V  
AquaForce e-HV Dimensions 3SV - 3 Pump

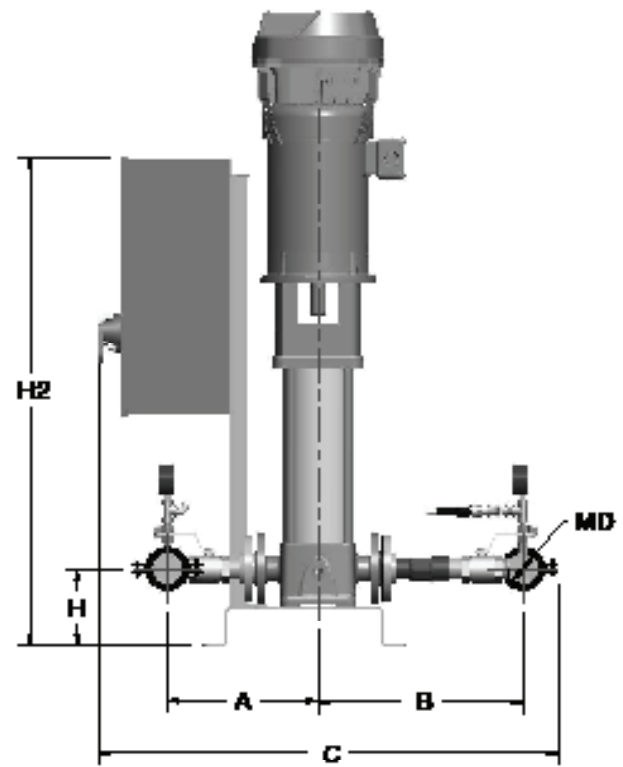
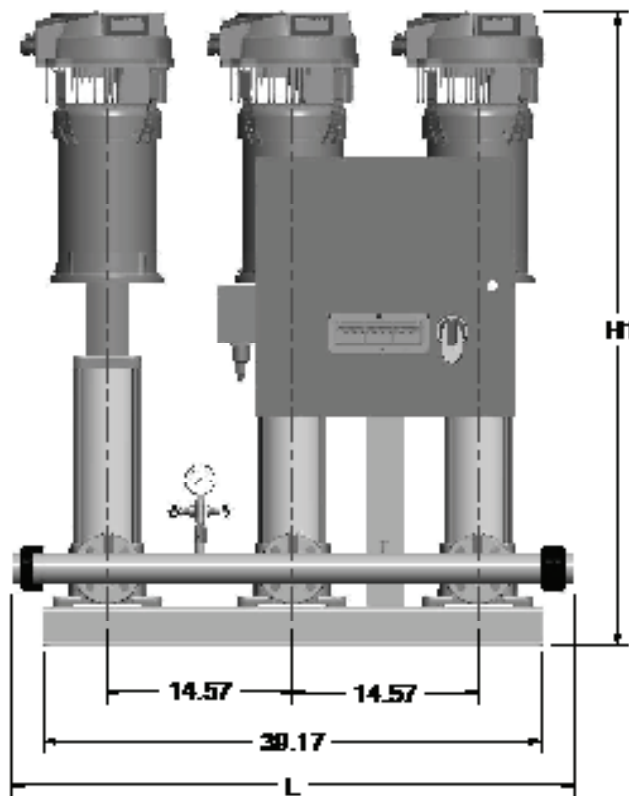

HVL3L2	MD	A	B	C	D	H	H1	H2	L	Wt.(lb)
3SV7GD4F80	2	11.82	18.09	38.12	42.57	11.12	37.42	23.24	44.20	508.2
3SV9GE4F80	2	11.82	18.09	38.12	42.57	11.12	38.01	23.24	44.20	522.1
3SV12GF4F80	2	11.82	18.09	38.12	42.57	11.12	43.85	23.24	44.20	604.9
3SV14GF4F80	2	11.82	18.09	38.12	42.57	11.12	45.45	23.24	44.20	611.8
3SV16GG4F80	2	11.82	18.09	38.12	42.57	11.12	48.12	23.24	44.20	768.1
3SV18GG4F80	2	11.82	18.09	38.12	42.57	11.12	51.29	23.24	44.20	779.9

208-230V  
AquaForce e-HV Dimensions 3SV - 4 Pump

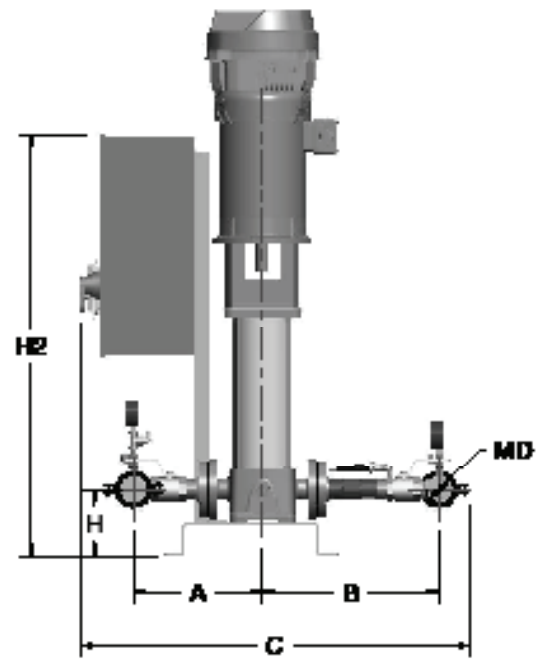
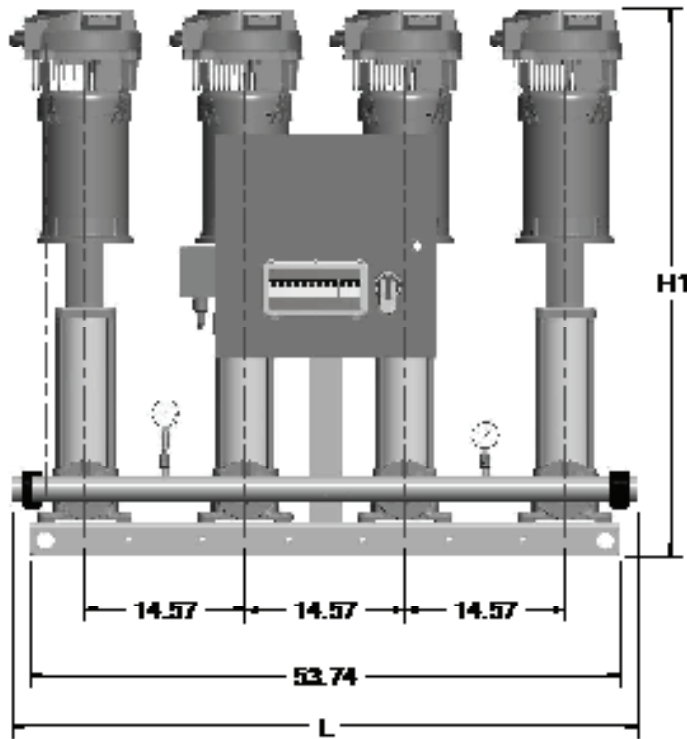
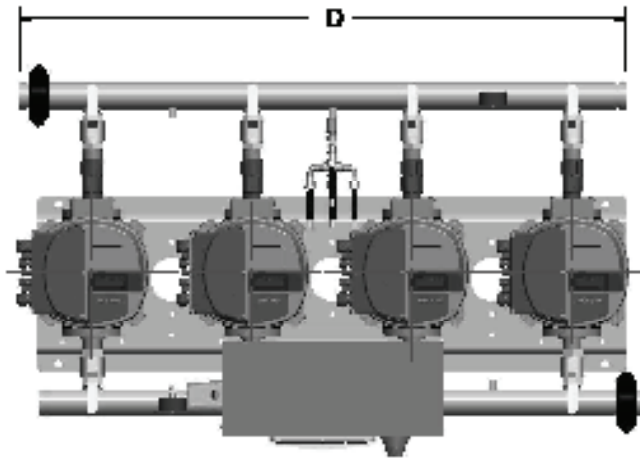

HVL4L2	MD	A	B	G	D	H	H1	H2	L	Wt.(Lb)
36V7GD4F80	2	11.77	18.00	25.53	55.20	8.10	27.43	23.24	58.85	858.11
36V9GE4F80	2	11.77	18.00	25.53	55.20	8.10	29.01	23.24	58.85	877.2
36V12GF4F80	2	11.77	18.00	25.53	55.20	8.10	43.88	23.24	58.85	787.7
36V14GF4F80	2	11.77	18.00	25.53	55.20	8.10	45.45	23.24	58.85	798.11
36V18GG4F80	2	11.77	18.00	25.53	55.20	8.10	49.12	23.24	58.85	1002.1
36V18GG4F80	2	11.77	18.00	25.53	55.20	8.10	51.29	23.24	58.85	1029.5

460V  
AquaForce e-HV Dimensions 3SV - 2 Pump

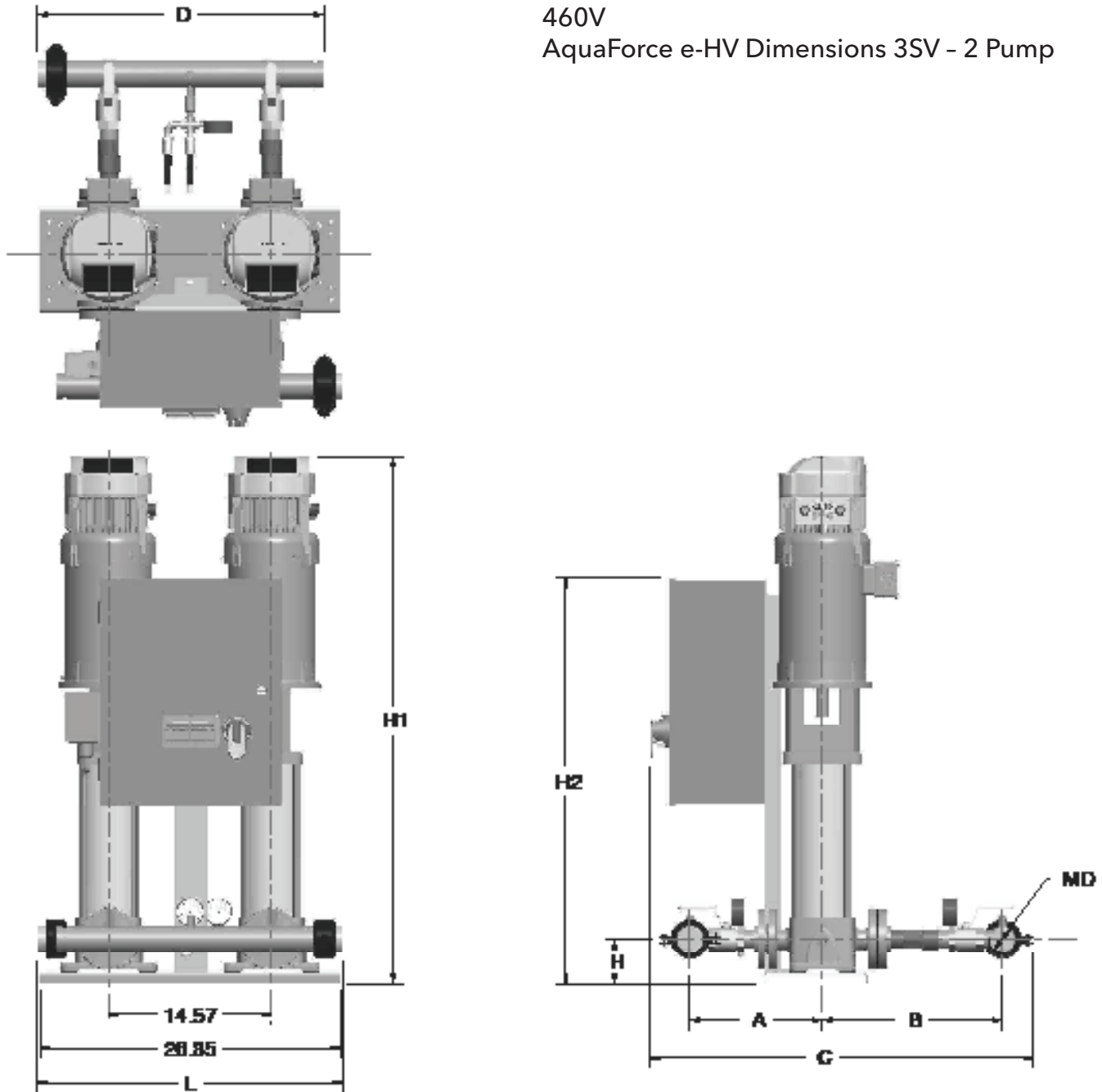

HVL202	MD	A	B	C	D	H	H1	H2	L	Wt. (lb)
35V7GD4F80	2	11.83	18.09	34.23	25.84	4.04	34.55	21.29	27.27	292.3
35V8GE4F80	2	11.83	18.09	34.23	25.84	4.04	27.13	21.29	27.27	408.4
35V12GF4F80	2	11.83	18.09	34.23	25.84	4.04	40.75	21.29	27.27	441.8
35V14GF4F80	2	11.83	18.09	34.23	25.84	4.04	42.25	21.29	27.27	448.2
35V16GG4C80	2	11.83	18.09	34.23	25.84	4.04	45.20	28.29	27.27	508.3
35V18GG4C80	2	11.83	18.09	34.23	25.84	4.04	47.50	28.29	27.27	517.5

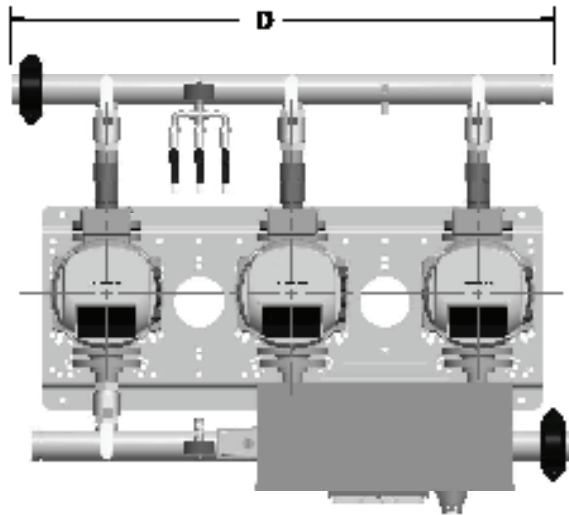

460V  
AquaForce e-HV Dimensions 3SV - 3 Pump

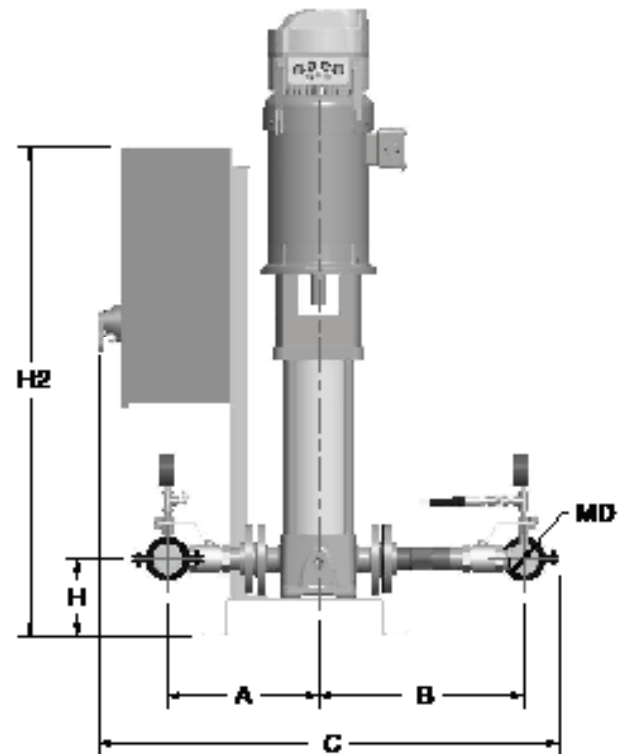
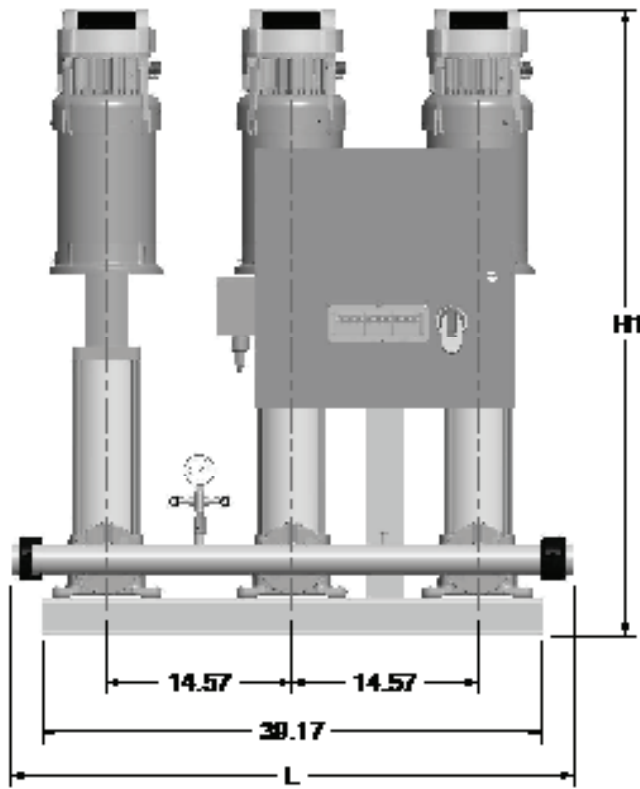

HVL3D2	MD	A	B	C	D	H	H1	H2	L	Wt.(lb)
35V7GD4F80	2	11.82	18.09	39.12	42.57	11.12	28.82	22.45	44.20	525.5
35V9GE4F80	2	11.82	18.09	39.12	42.57	11.12	29.20	22.45	44.20	559.7
35V12GF4F80	2	11.82	18.09	39.12	42.57	11.12	42.75	22.45	44.20	808.0
35V14GF4F80	2	11.82	18.09	39.12	42.57	11.12	44.28	22.45	44.20	814.9
35V16GG4C80	2	11.82	18.09	39.12	42.57	11.12	47.28	22.45	44.20	708.0
35V18GG4C80	2	11.82	18.09	39.12	42.57	11.12	48.82	22.45	44.20	721.8

460V  
AquaForce e-HV Dimensions 3SV - 4 Pump

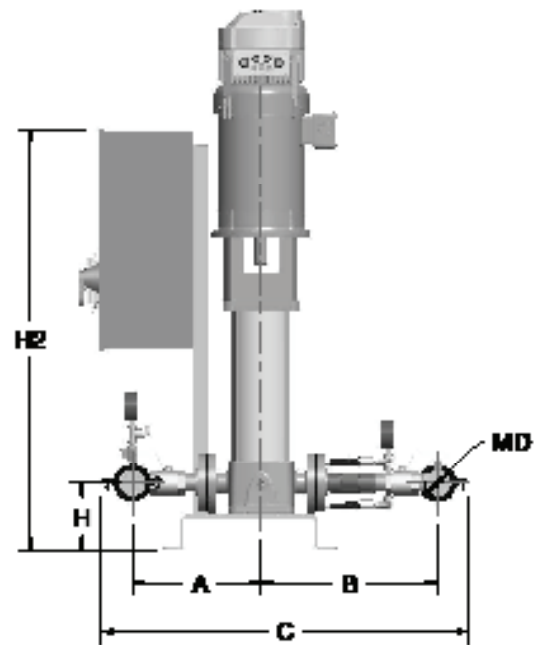
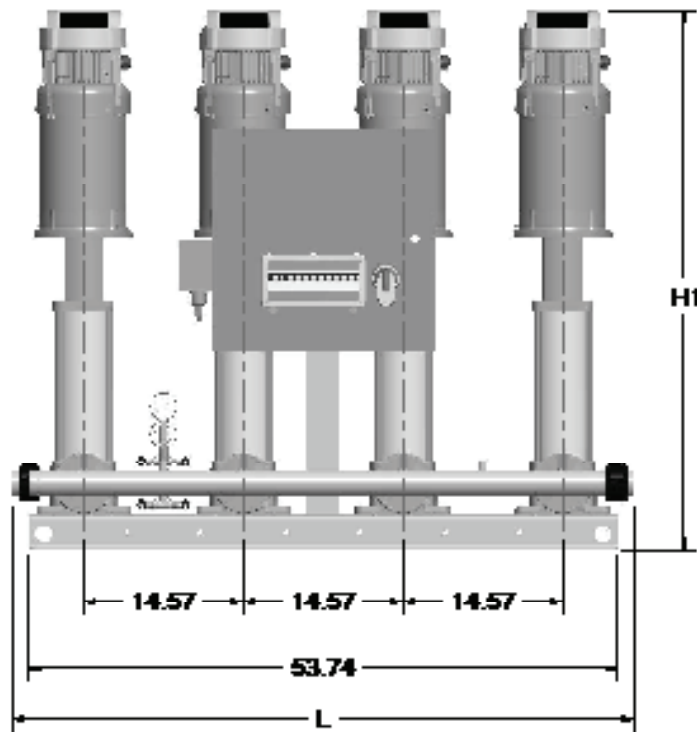
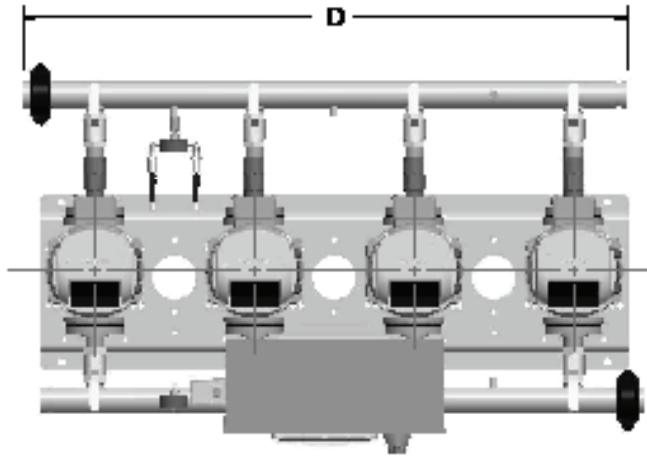

HVL402	MD	A	B	G	D	H	H1	H2	L	Wt.(lb)
36V7SD4F80	2	11.77	16.09	23.48	55.17	6.10	28.62	23.24	58.78	702.7
36V8GE4F80	2	11.77	16.09	23.48	55.17	6.10	29.20	23.24	58.78	732.8
36V12GF4F80	2	11.77	16.09	23.48	55.17	6.10	42.75	23.24	58.78	797.3
36V14GF4F80	2	11.77	16.09	23.48	55.17	6.10	44.28	23.24	58.78	808.5
36V16GG4C80	2	11.77	16.09	23.48	55.17	6.10	47.28	28.24	58.78	832.7
36V18GG4C80	2	11.77	16.09	23.48	55.17	6.10	49.63	28.24	58.78	848.1

# AquaForce e-HV Curves 5SV

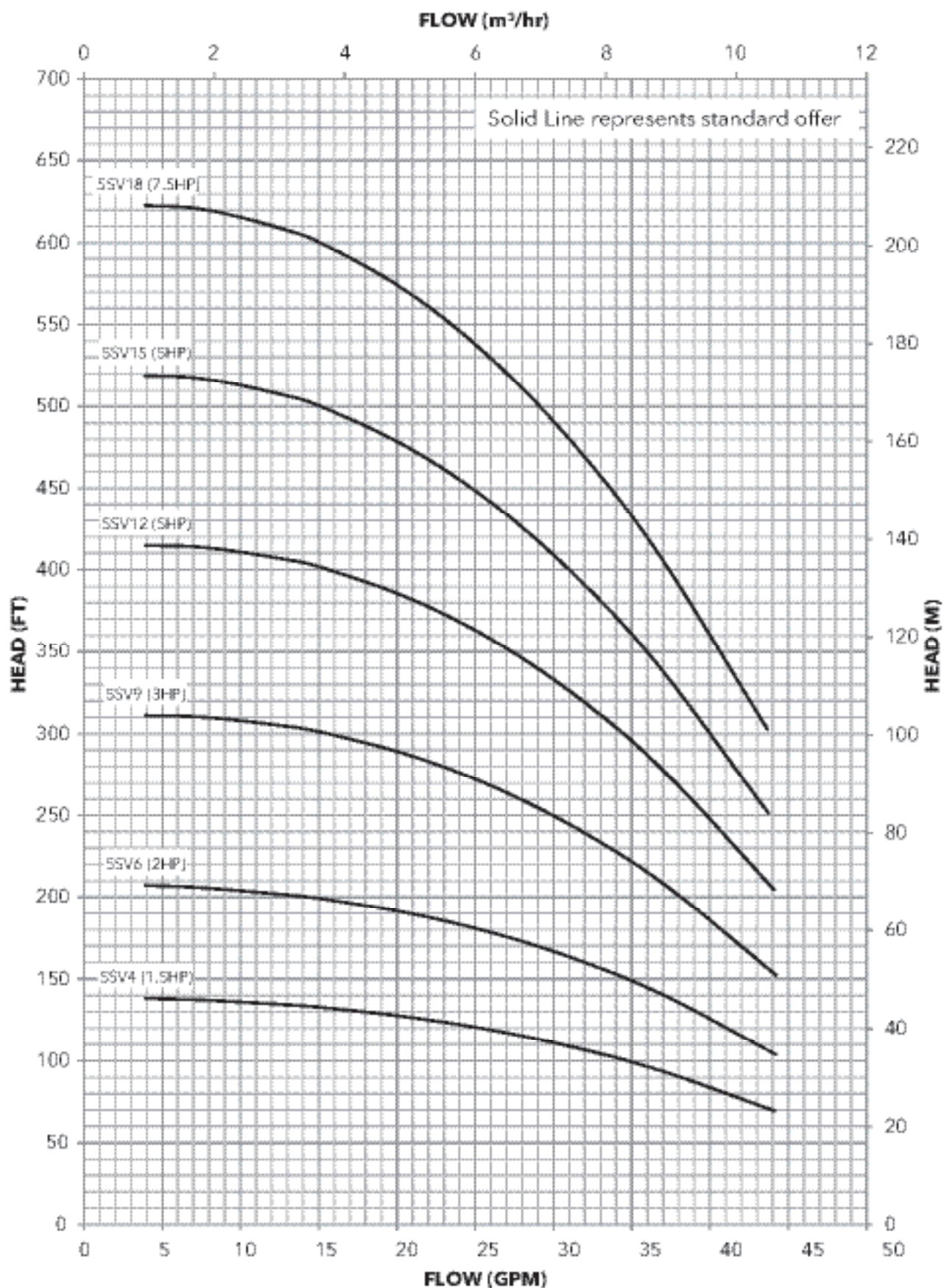



# AquaForce e-HV Curves 5SV

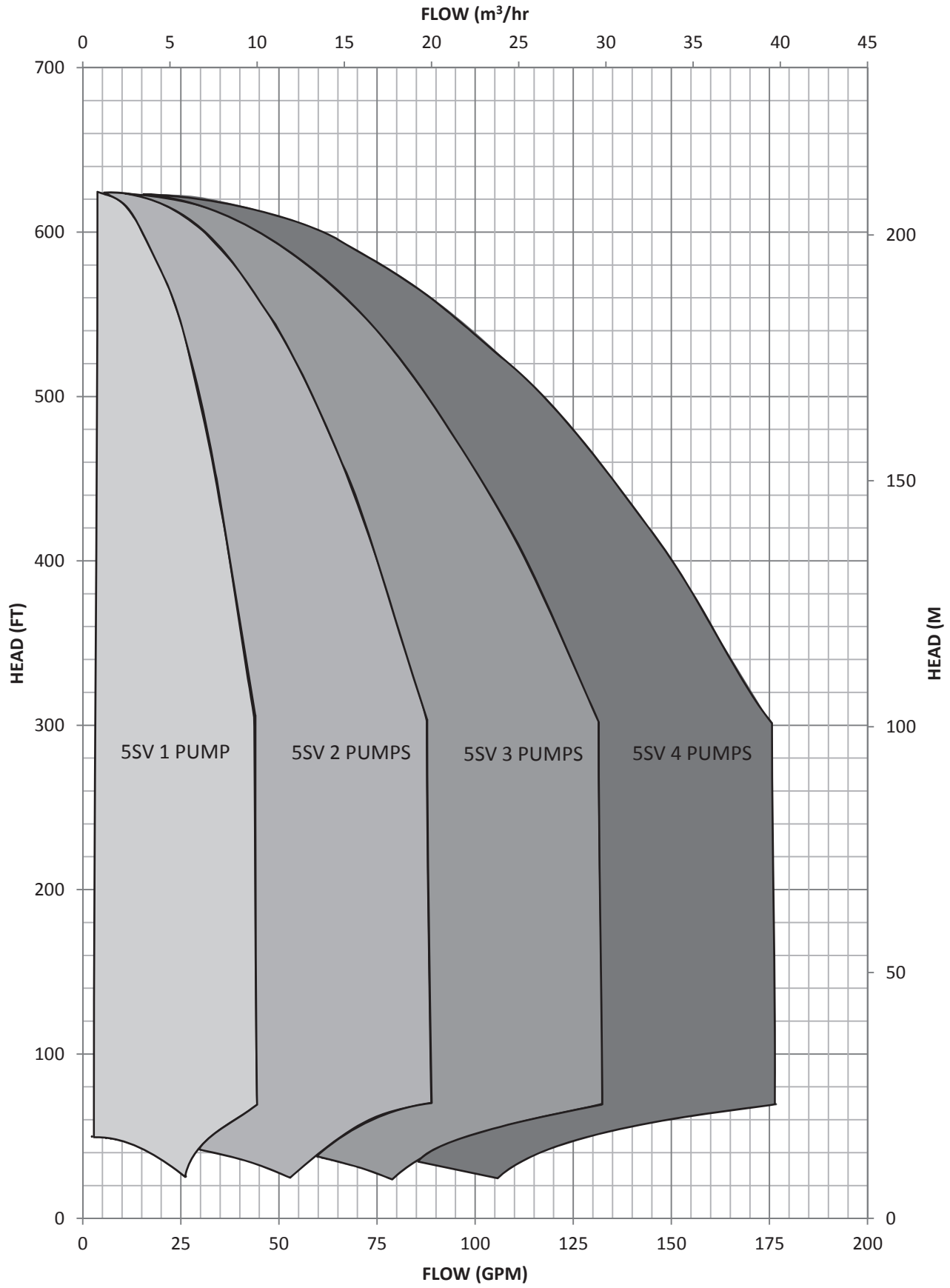

208-230V  
AquaForce e-HV Dimensions 5SV - 2 Pump

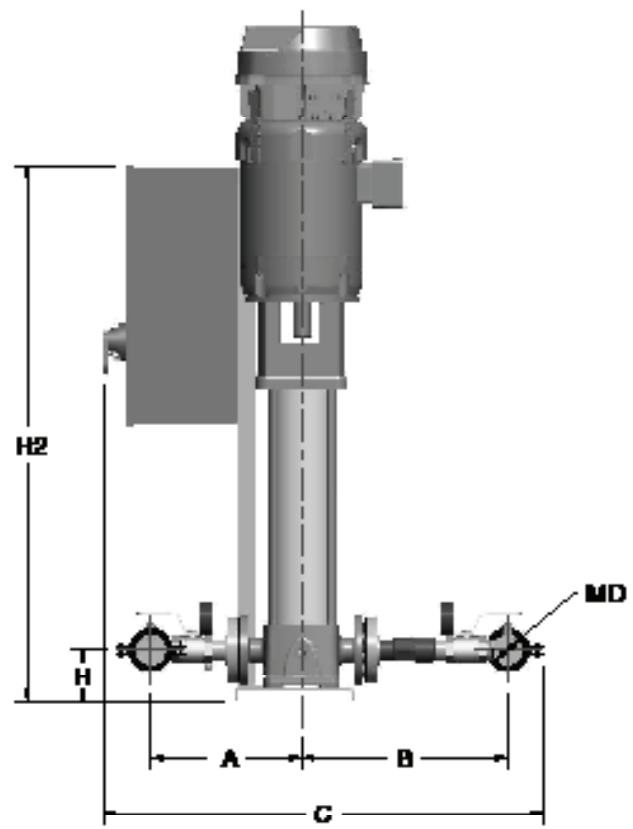
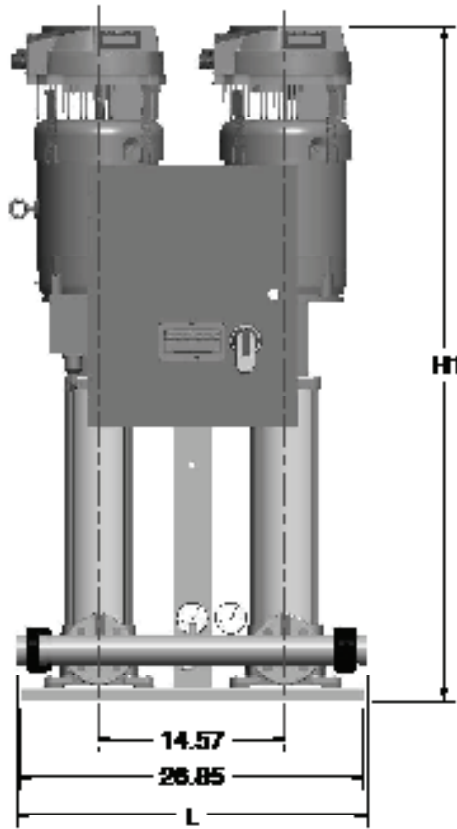
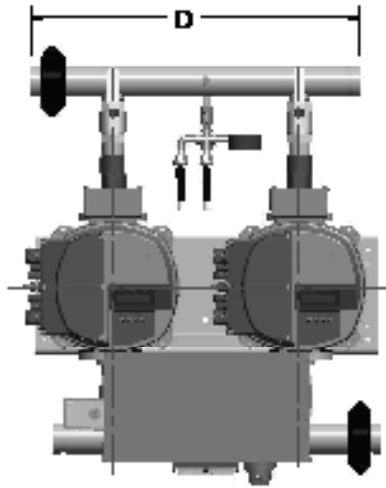

HVL2L2	MD	A	B	C	D	H	H1	H2	L	Wt.(lb)
5SV4GD4F80	2	11.80	18.07	34.21	25.87	4.08	23.79	21.27	27.22	228.5
5SV8GE4F80	2	11.80	18.07	34.21	25.87	4.08	25.75	21.27	27.22	251.7
5SV8GF4F80	2	11.80	18.07	34.21	25.87	4.08	41.22	21.27	27.22	280.9
5SV12GG4G80	2	11.80	18.07	34.21	25.87	4.08	48.88	28.27	27.22	501.2
5SV15GG4G80	2	11.80	18.07	34.21	25.87	4.08	48.81	28.27	27.22	508.1
5SV18GH4F80	2	11.80	18.07	34.21	25.87	4.08	52.85	41.77	27.22	807.0

208-230V  
AquaForce e-HV Dimensions 5SV - 3 Pump

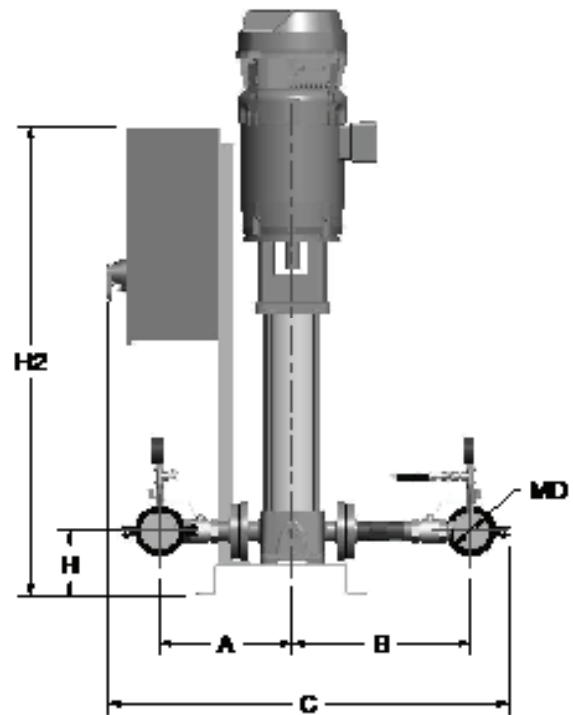
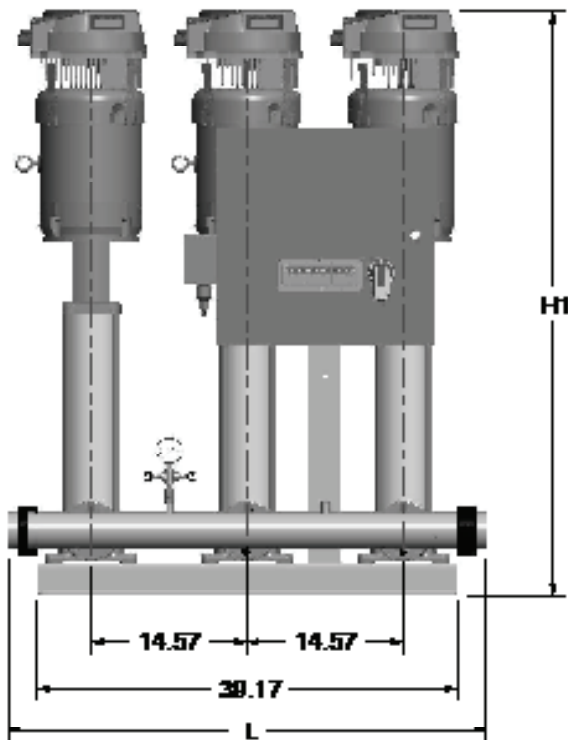
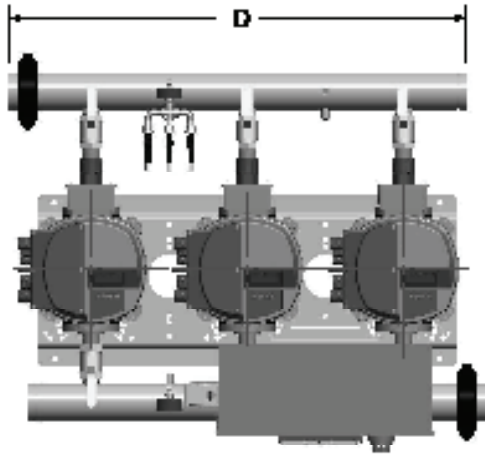

HVL3L2	MD	A	B	C	D	H	H1	H2	L	Wt.(lb)
5SV4GD4F80	2	11.80	18.07	38.10	42.80	11.12	35.80	32.24	44.28	501.5
5SV8GE4F80	2	11.80	18.07	38.10	42.80	11.12	37.82	32.24	44.28	515.2
5SV8GF4F80	2	11.80	18.07	38.10	42.80	11.12	43.28	32.24	44.28	586.1
5SV12GG4F80	2	11.80	18.07	38.10	42.80	11.12	48.02	38.24	44.28	782.8
5SV15GG4F80	2	11.80	18.07	38.10	42.80	11.12	51.83	38.24	44.28	773.0
5SV18GH4F80	2	11.80	18.07	38.10	42.80	11.12	55.02	43.84	44.28	820.2
HVL3L3	MD	A	B	C	D	H	H1	H2	L	Wt.(lb)
5SV4GD4F80	3	12.28	18.84	37.43	42.72	11.12	35.80	32.24	44.51	518.1
5SV8GE4F80	3	12.28	18.84	37.43	42.72	11.12	37.82	32.24	44.51	521.9
5SV8GF4F80	3	12.28	18.84	37.43	42.72	11.12	43.28	32.24	44.51	614.7
5SV12GG4F80	3	12.28	18.84	37.43	42.72	11.12	48.02	38.24	44.51	779.2
5SV15GG4F80	3	12.28	18.84	37.43	42.72	11.12	51.83	38.24	44.51	789.8
5SV18GH4F80	3	12.28	18.84	37.43	42.72	11.12	55.02	43.84	44.51	828.9

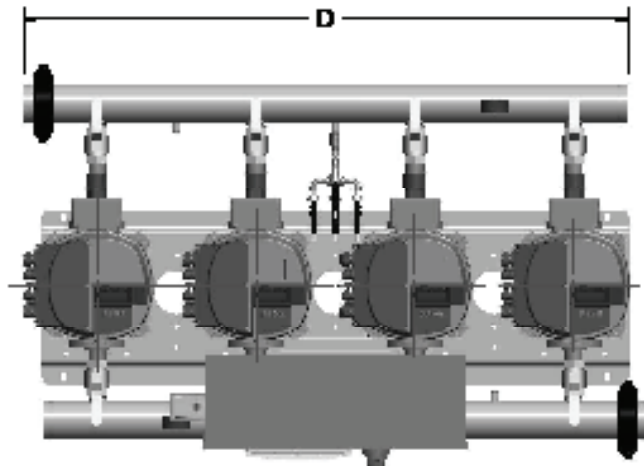

208-230V  
AquaForce e-HV Dimensions 5SV - 4 Pump

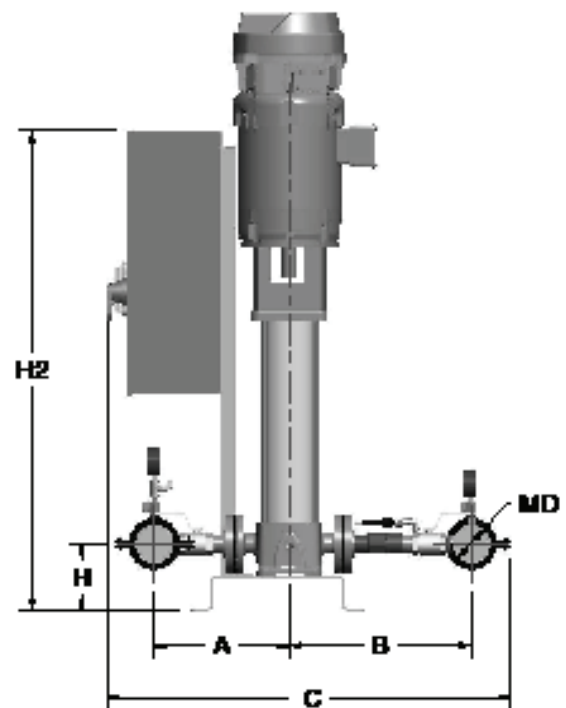
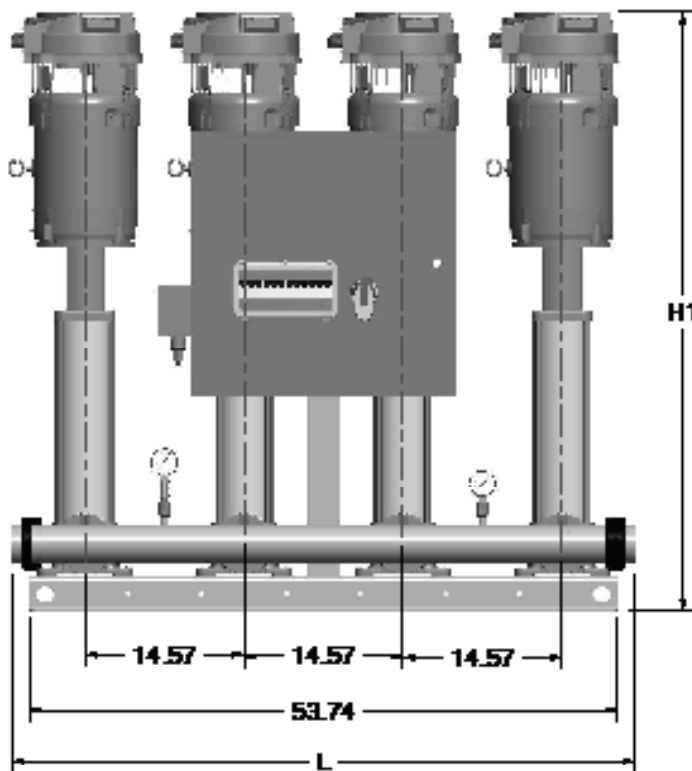

HVL4L3	MD	A	B	C	D	H	H1	H2	L	Wt.(Lbs)
56V4GD4F80	2	12.32	18.65	28.90	55.32	6.10	35.88	32.24	57.12	670.6
56V8GE4F80	2	12.32	18.65	28.90	55.32	6.10	37.82	32.24	57.12	689.0
56V8GF4F80	2	12.32	18.65	28.90	55.32	6.10	42.28	32.24	57.12	789.4
56V12GG4F80	2	12.32	18.65	28.90	55.32	6.10	48.02	32.24	57.12	1018.2
56V15GG4F80	2	12.32	18.65	28.90	55.32	6.10	51.98	32.24	57.12	1032.0
56V18GH4F80	2	12.32	18.65	28.90	55.32	6.10	55.02	42.84	57.12	1284.8

460V  
AquaForce e-HV Dimensions 5SV - 2 Pump

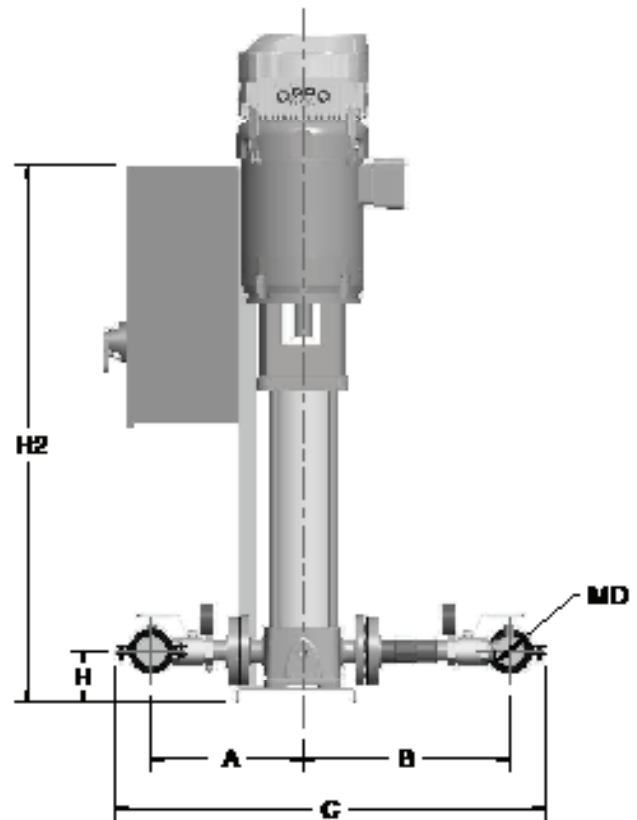
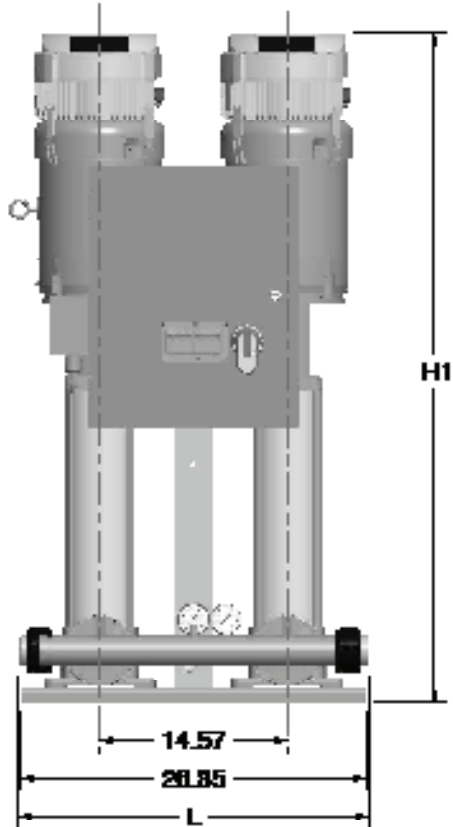
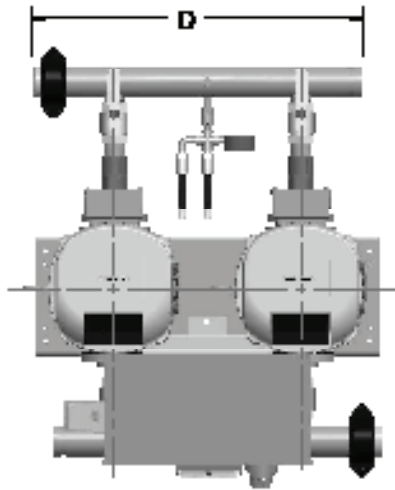

HVL202	MD	A	B	C	D	H	H1	H2	L	Wt.(lb)
5SV4GD4F80	2	11.80	18.07	34.80	25.84	4.08	22.88	21.27	27.27	283.8
5SV8GE4F80	2	11.80	18.07	34.80	25.84	4.08	25.84	21.27	27.27	400.0
5SV8GF4F80	2	11.80	18.07	34.80	25.84	4.08	40.12	21.27	27.27	422.2
5SV12GG4C80	2	11.80	18.07	34.80	25.84	4.08	45.12	28.27	27.27	501.2
5SV15GG4C80	2	11.80	18.07	34.80	25.84	4.08	48.12	28.27	27.27	508.1
5SV18GH4F80	2	11.80	18.07	34.80	25.84	4.08	52.28	41.77	27.27	558.4

460V  
AquaForce e-HV Dimensions 5SV - 3 Pump

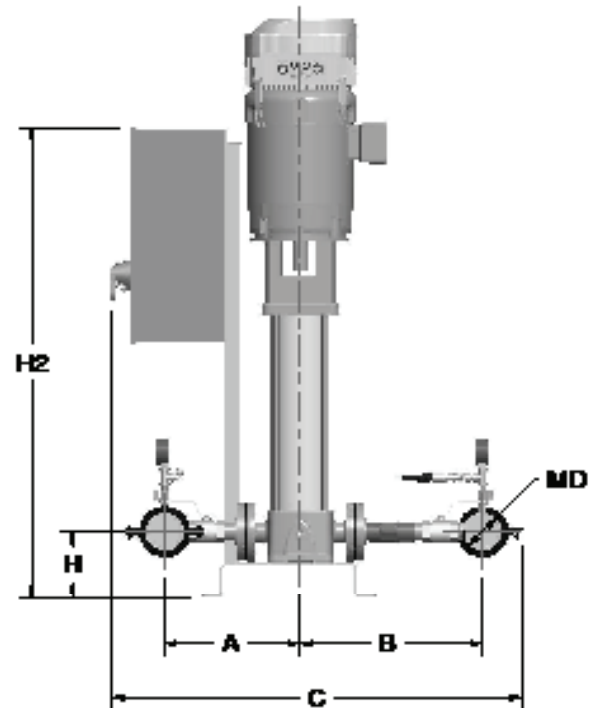
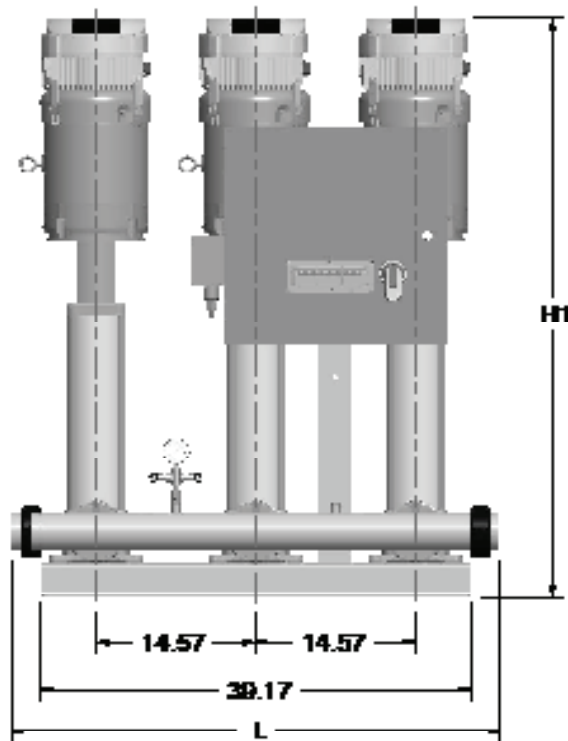
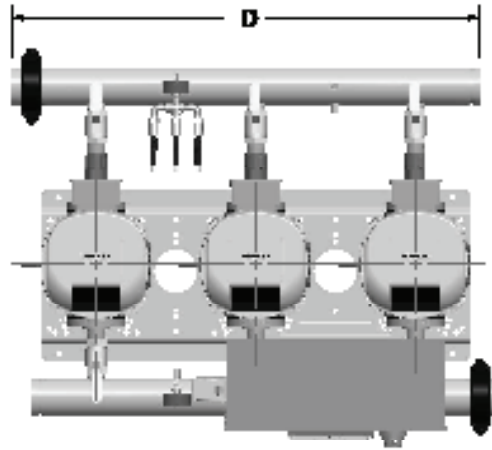

HVL3D2	MD	A	B	C	D	H	H1	H2	L	Wt.(lb)
5SV4GD4F80	2	11.80	18.07	38.10	42.57	8.12	35.05	32.34	44.20	520.4
5SV8GE4F80	2	11.80	18.07	38.10	42.57	8.12	38.01	32.34	44.20	544.8
5SV8GF4F80	2	11.80	18.07	38.10	42.57	8.12	42.25	32.34	44.20	582.9
5SV12GG4C80	2	11.80	18.07	38.10	42.57	8.12	47.25	38.34	44.20	698.4
5SV15GG4C80	2	11.80	18.07	38.10	42.57	8.12	50.12	38.34	44.20	708.7
5SV18GH4F80	2	11.80	18.07	38.10	42.57	8.12	54.50	42.84	44.20	779.2
HVL3D3	MD	A	B	C	D	H	H1	H2	L	Wt.(lb)
5SV4GD4F80	3	12.28	18.84	38.25	42.70	8.12	25.05	22.34	44.47	527.0
5SV8GE4F80	3	12.28	18.84	38.25	42.70	8.12	28.01	22.34	44.47	581.2
5SV8GF4F80	3	12.28	18.84	38.25	42.70	8.12	42.25	22.34	44.47	600.5
5SV12GG4C80	3	12.28	18.84	38.25	42.70	8.12	47.25	28.34	44.47	713.0
5SV15GG4C80	3	12.28	18.84	38.25	42.70	8.12	50.12	28.34	44.47	723.2
5SV18GH4F80	3	12.28	18.84	38.25	42.70	8.12	54.50	42.84	44.47	785.8

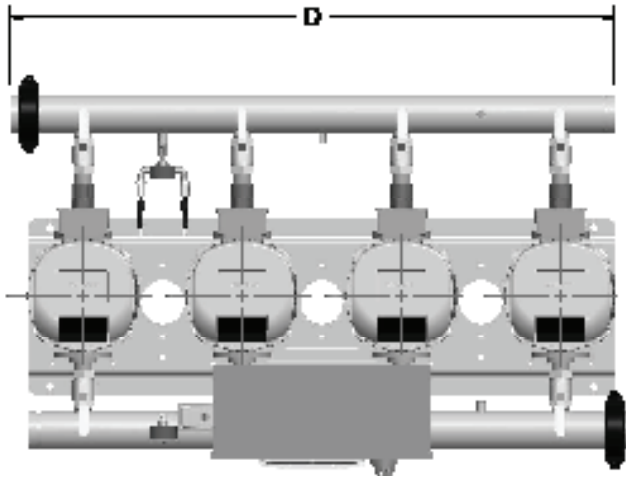

460V  
AquaForce e-HV Dimensions 5SV - 4 Pump

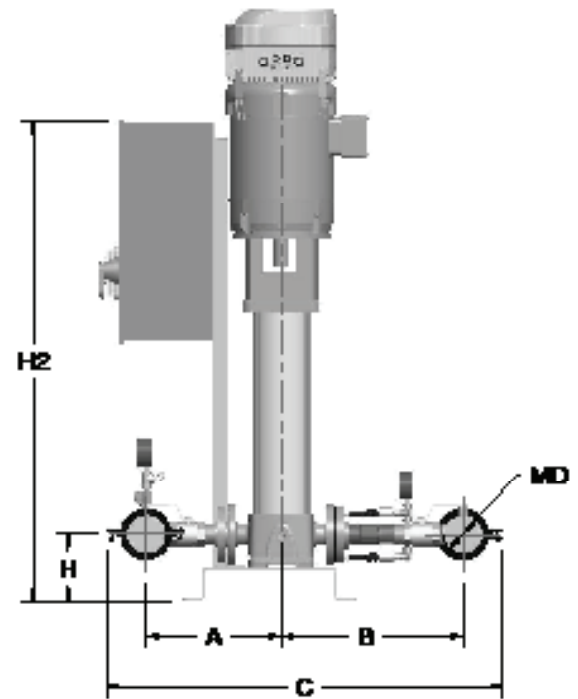
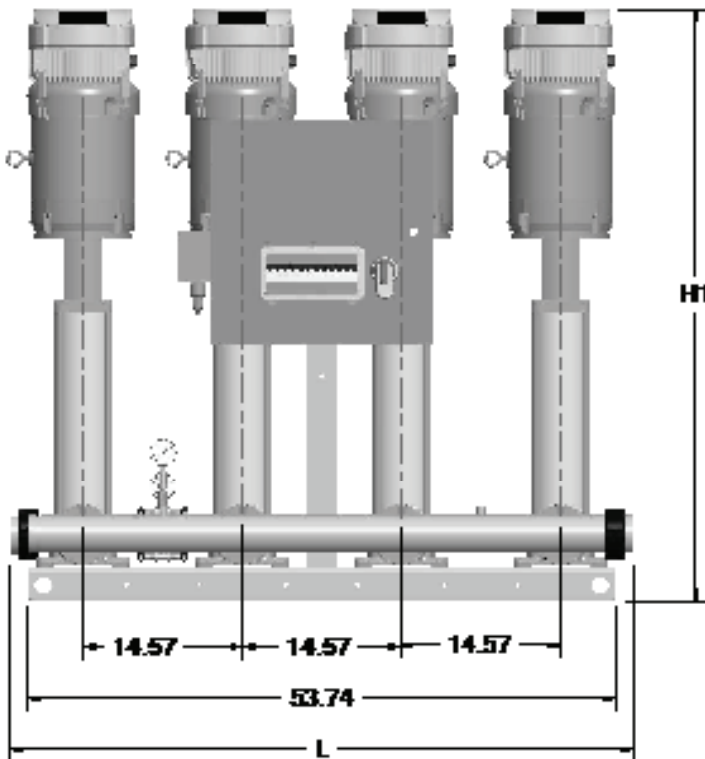

HVL403	MD	A	B	C	D	H	H1	H2	L	Wt.(#)
56V4GD4F80	2	12.38	18.04	28.25	55.28	8.12	35.05	32.24	57.08	700.4
56V8GE4F80	2	12.38	18.04	28.25	55.28	8.12	38.01	32.24	57.08	722.8
56V8GF4F80	2	12.38	18.04	28.25	55.28	8.12	42.25	32.24	57.08	787.0
56V12GG4C80	2	12.38	18.04	28.25	55.28	8.12	47.25	32.24	57.08	925.0
56V15GG4C80	2	12.38	18.04	28.25	55.28	8.12	52.12	32.24	57.08	943.8
56V18GH4F80	2	12.38	18.04	28.25	55.28	8.12	54.50	42.84	57.08	1045.4

# AquaForce e-HV Curves 10SV

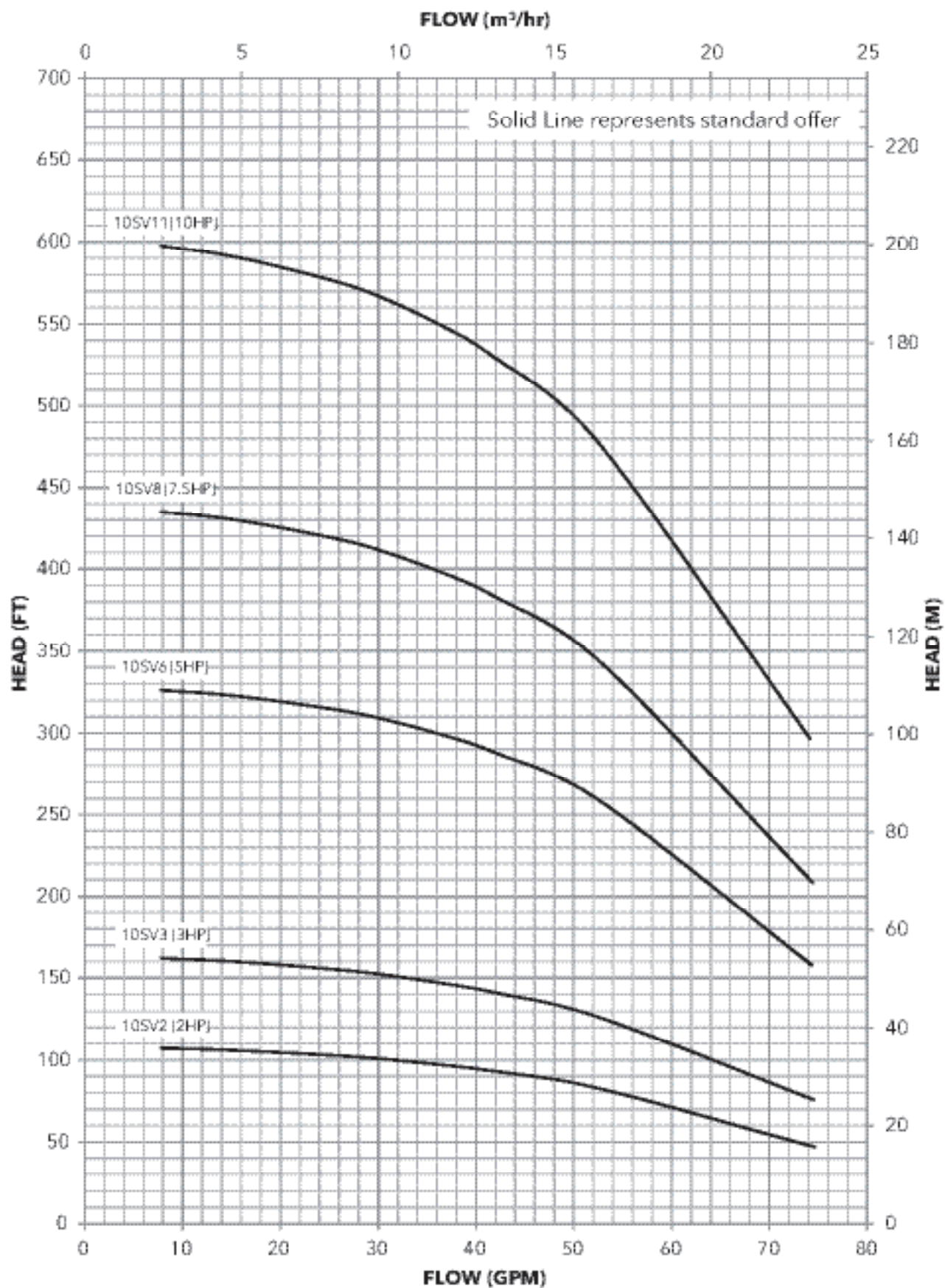



# AquaForce e-HV Curves 10SV

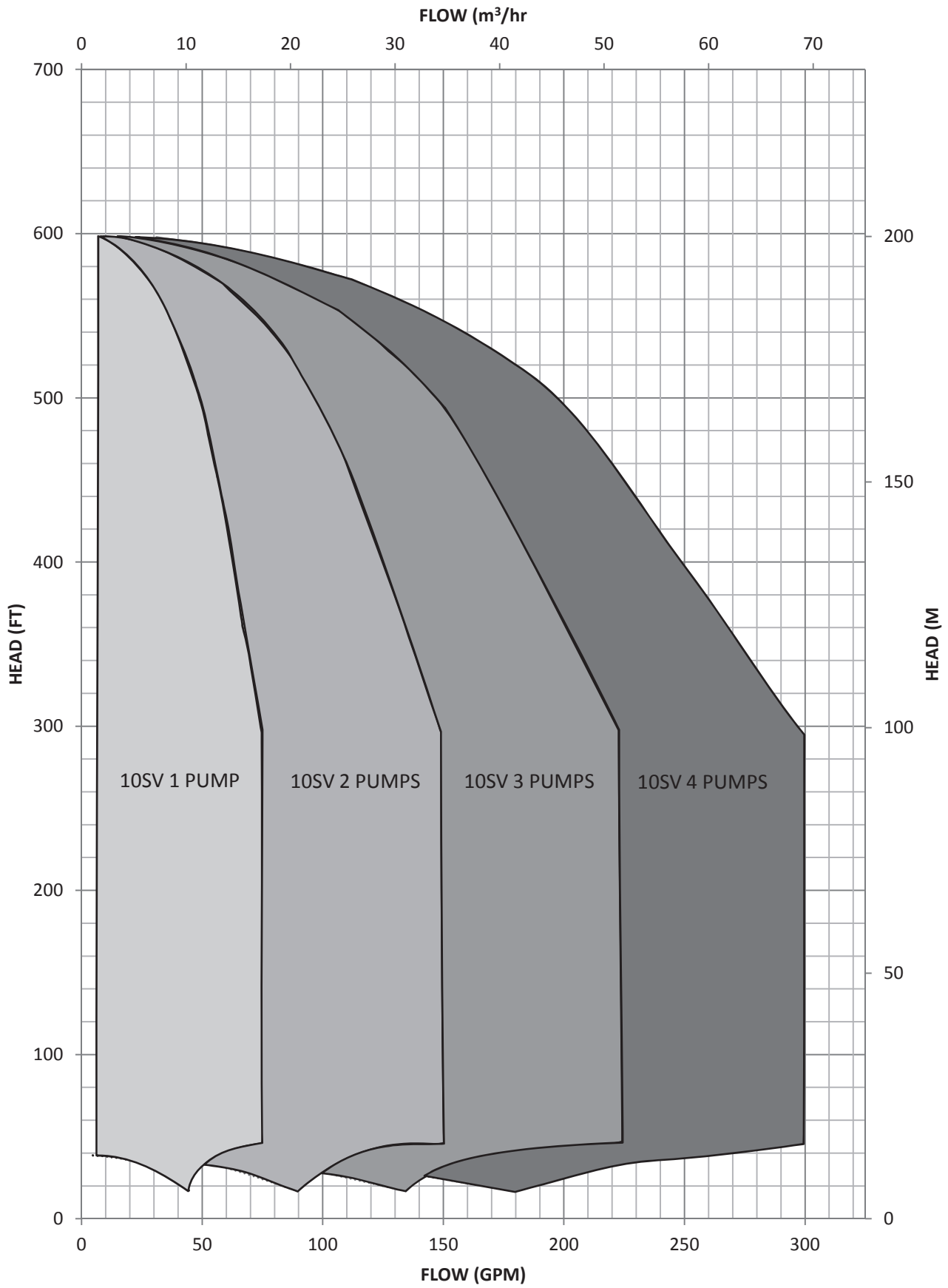

208-230V  
AquaForce e-HV Dimensions 10SV - 2 Pump

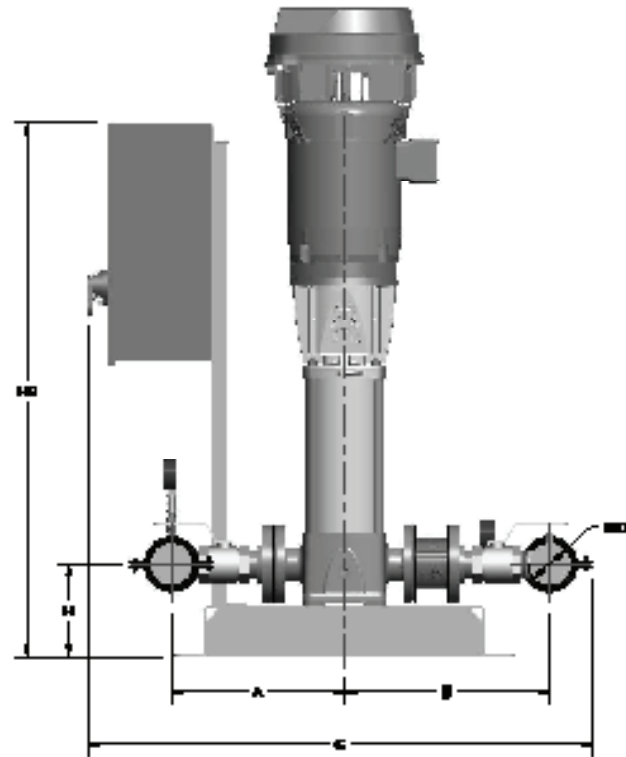
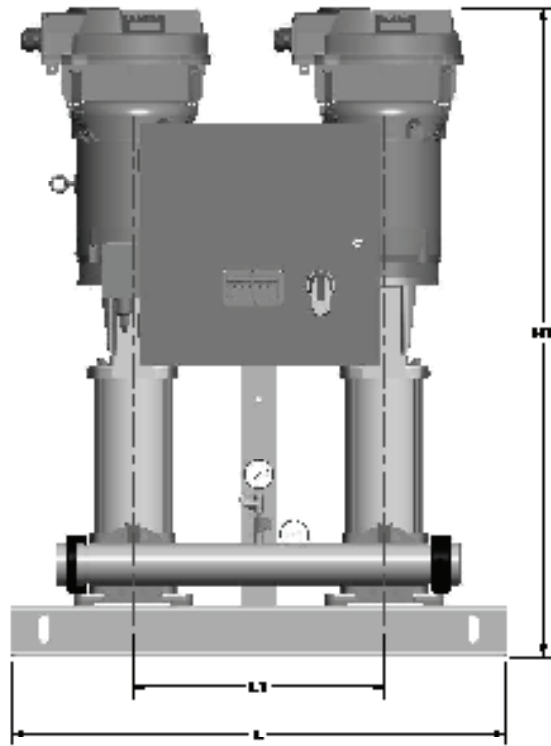
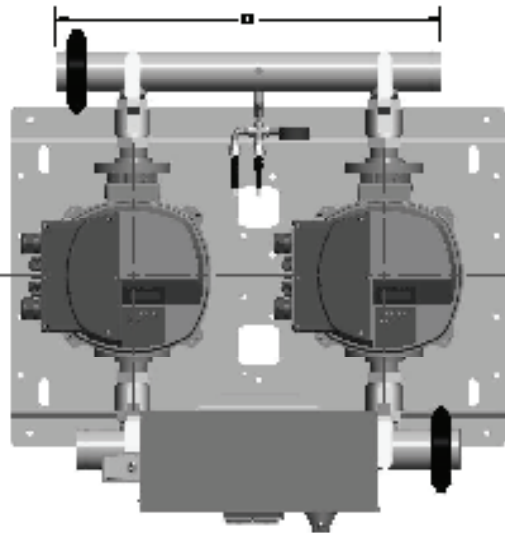

HVL2L2	MD	A	B	C	D	H	H1	H2	L	L1	Wt. (lb)
10SV2GE4F80	2	14.02	16.78	28.42	25.67	6.68	37.57	22.24	27.22	14.57	408.8
10SV3GF4F80	2	14.02	16.78	28.42	25.67	6.68	41.24	32.24	27.22	14.57	481.7
10SV6GG4C80	2	14.02	16.78	28.42	25.67	6.68	47.71	38.24	27.22	14.57	581.8
10SV8GH4F80	2	14.02	16.78	28.42	25.67	6.68	52.21	38.24	27.22	14.57	678.0
10SV11G4MF80	2	14.02	16.78	41.22	22.27	7.87	57.85	45.02	41.72	21.28	804.2

HVL2L3	MD	A	B	C	D	H	H1	H2	L	L1	Wt. (lb)
10SV2GE4F80	3	14.59	17.24	29.17	25.82	6.68	37.57	32.24	27.58	14.57	418.8
10SV3GF4F80	3	14.59	17.24	29.17	25.82	6.68	41.24	32.24	27.58	14.57	472.7
10SV6GG4C80	3	14.59	17.24	29.17	25.82	6.68	47.71	38.24	27.58	14.57	592.8
10SV8GH4F80	3	14.59	17.24	29.17	25.82	6.68	52.21	38.24	27.58	14.57	688.0
10SV11G4MF80	3	14.59	17.24	42.59	22.48	7.87	57.85	45.02	41.72	21.28	807.4

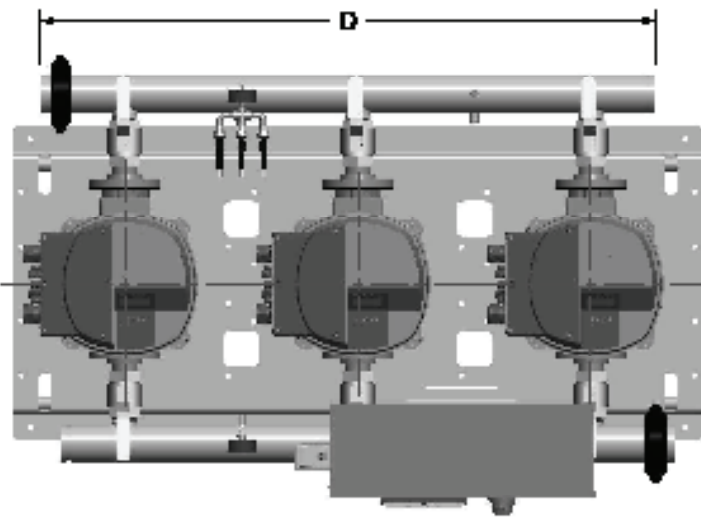

208-230V  
AquaForce e-HV Dimensions 10SV - 3 Pump

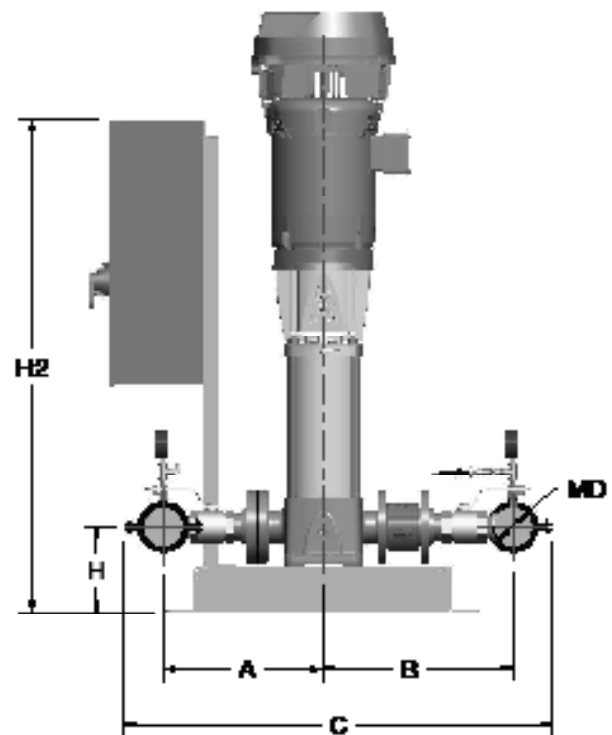
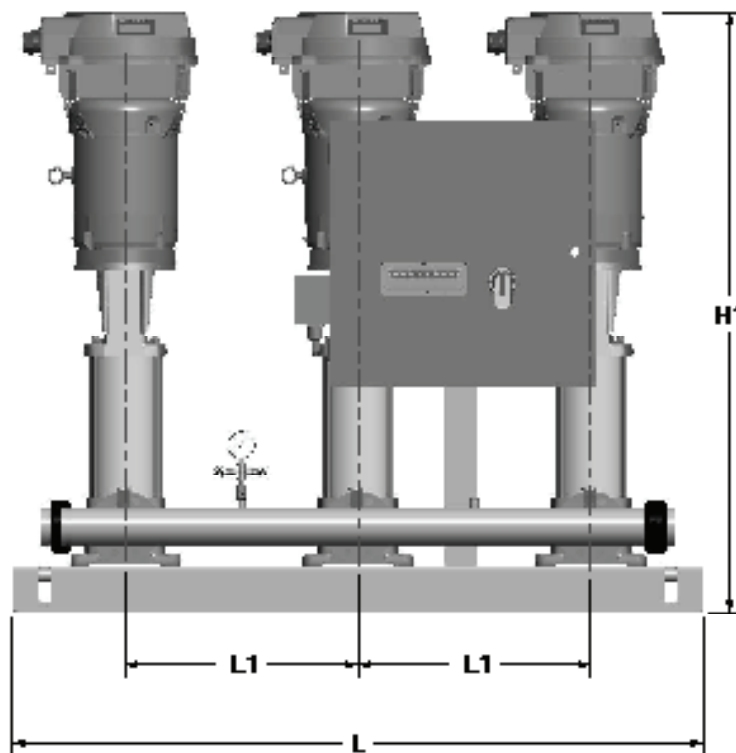

HVL3L3	MD	A	B	C	D	H	H1	H2	L	L1	Wt. (lb)
10SV2GE4F80	3	14.50	17.24	20.17	42.72	6.00	77.57	22.24	44.51	14.57	113.4
10SV3GF4F80	3	14.50	17.24	20.17	42.72	6.00	41.24	22.24	44.51	14.57	102.7
10SV8GG4F80	3	14.50	17.24	20.17	42.72	6.00	47.71	22.24	44.51	14.57	112.3
10SV8GH4F80	3	14.50	17.24	20.17	42.72	6.00	50.21	22.24	44.51	14.57	1011.2
10SV11G4F80	3	14.50	17.24	42.25	58.11	7.07	57.05	45.02	82.00	21.28	1271.9

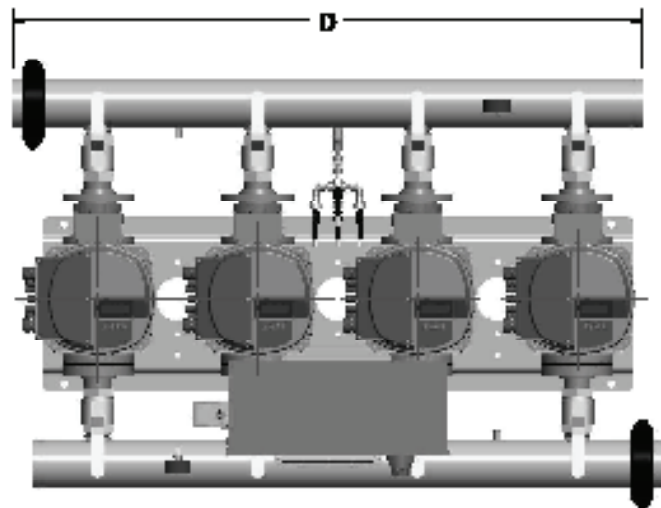

208-230V  
AquaForce e-HV Dimensions 10SV - 4 Pump

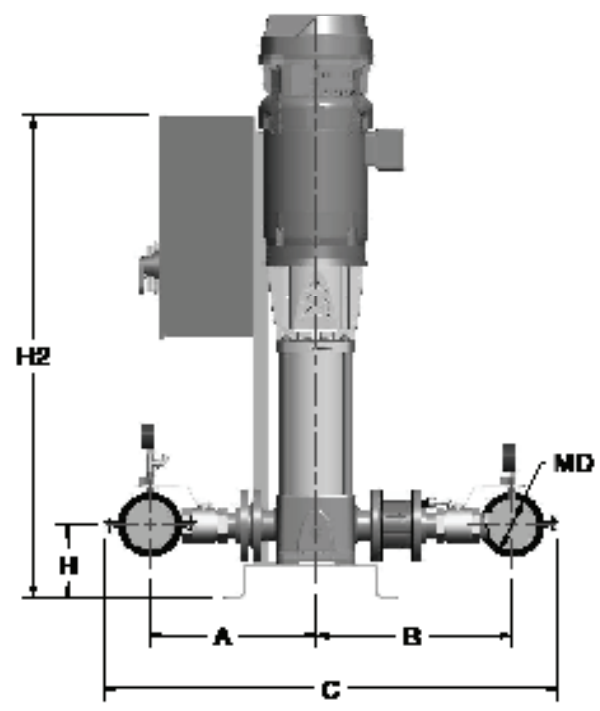
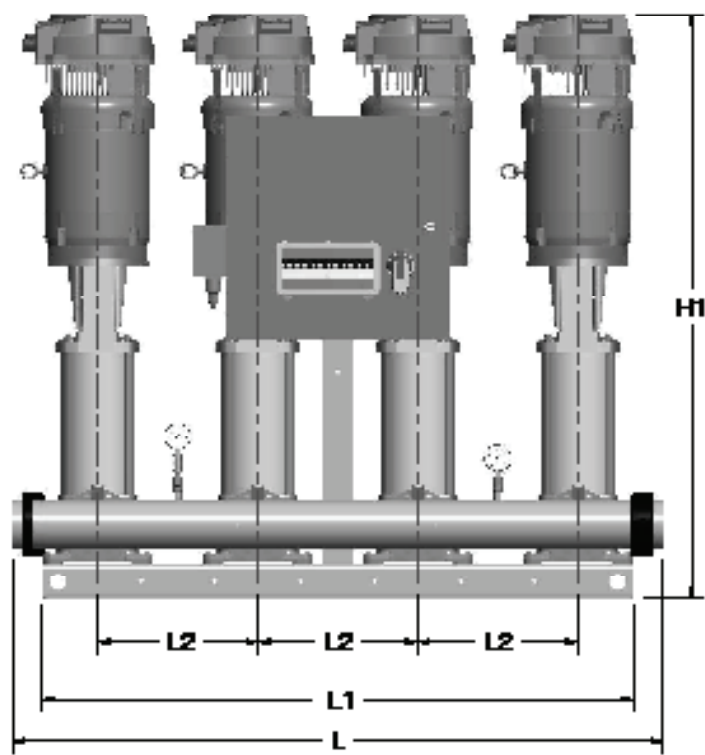

HVL4L3	MD	A	B	C	D	H	H1	H2	L	L1	L2	Wt.(lb)
10SV2GE4F80	3	14.58	17.34	28.18	56.22	8.68	37.57	23.24	57.10	52.74	14.57	797.5
10SV3GF4F80	3	14.58	17.34	28.18	56.22	8.68	41.24	23.24	57.10	52.74	14.57	902.2
10SV8GG4F80	3	14.58	17.34	28.18	56.22	8.68	47.71	23.24	57.10	52.74	14.57	1142.4
10SV8GH4F80	3	14.58	17.34	28.18	56.22	8.68	50.21	23.24	57.10	52.74	14.57	1281.8
10SV11GJ4F80	3	14.58	17.34	42.25	75.40	7.87	57.85	45.02	85.82	85.82	21.28	1814.2

HVL4L4	MD	A	B	C	D	H	H1	H2	L	L1	L2	Wt.(lb)
10SV2GE4F80	4	15.00	17.84	41.20	57.28	8.69	37.57	23.24	59.20	52.74	14.57	818.8
10SV3GF4F80	4	15.00	17.84	41.20	57.28	8.69	41.24	23.24	59.20	52.74	14.57	925.8
10SV8GG4F80	4	15.00	17.84	41.20	57.28	8.69	47.71	23.24	59.20	52.74	14.57	1185.7
10SV8GH4F80	4	15.00	17.84	41.20	57.28	8.69	50.21	23.24	59.20	52.74	14.57	1412.8
10SV11GJ4F80	4	15.00	17.84	42.24	77.43	7.87	57.85	45.02	85.82	85.82	21.28	1828.1

460V  
AquaForce e-HV Dimensions 10SV - 2 Pump

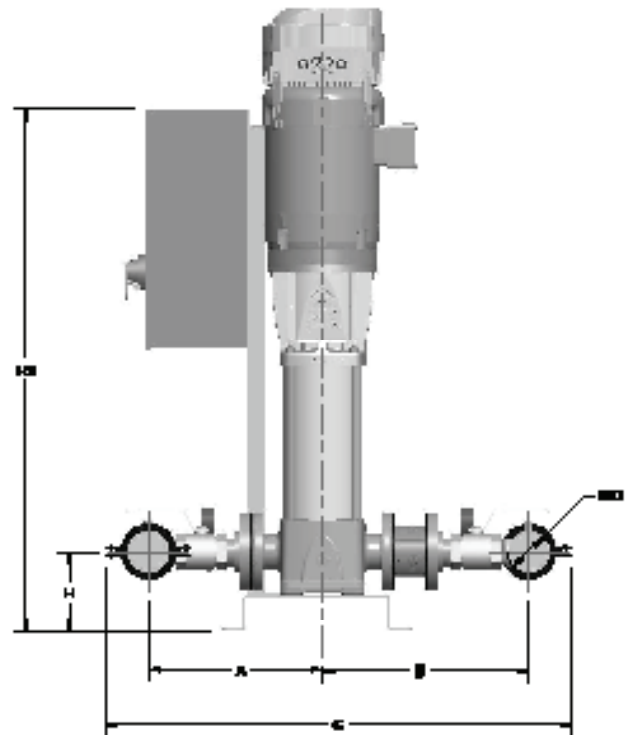
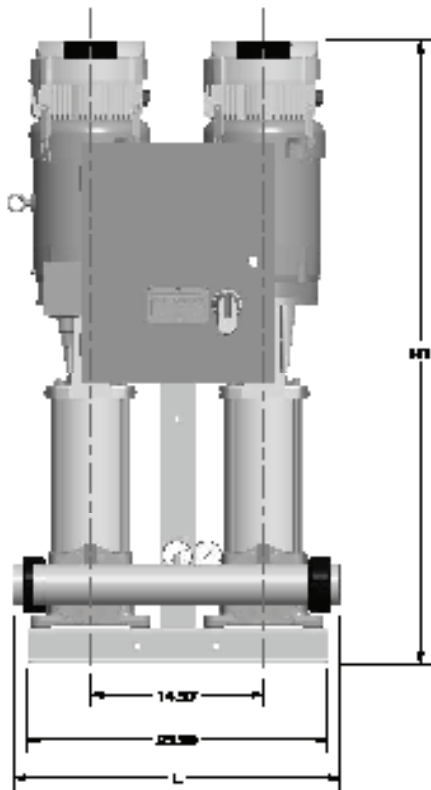
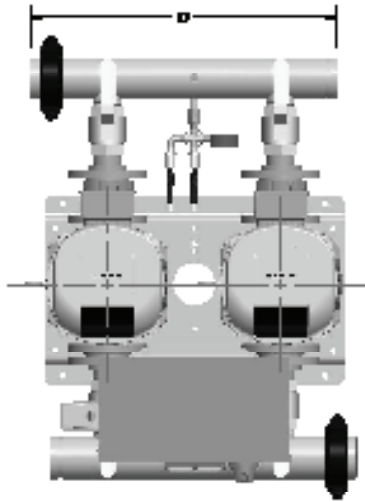

HVL2D2	MD	A	B	C	D	H	H1	H2	L	Wt.(lb)
10SV2GE4F80	2	14.03	18.78	28.42	25.84	8.89	27.78	23.24	27.27	487.4
10SV3GF4F80	2	14.03	18.78	28.42	25.84	8.89	40.25	23.24	27.27	487.3
10SV8GG4C80	2	14.03	18.78	28.42	25.84	8.89	45.86	23.24	27.27	577.8
10SV8GH4F80	2	14.03	18.78	28.42	25.84	8.89	48.25	23.24	27.27	623.8
10SV11GJ4F80	2	14.03	18.78	28.42	25.84	8.89	54.13	42.84	27.27	741.1

HVL2D3	MD	A	B	C	D	H	H1	H2	L	Wt.(lb)
10SV2GE4F80	2	14.50	17.24	28.17	25.77	8.89	27.78	23.24	27.52	482.8
10SV3GF4F80	2	14.50	17.24	28.17	25.77	8.89	40.25	23.24	27.52	512.5
10SV8GG4C80	2	14.50	17.24	28.17	25.77	8.89	45.86	23.24	27.52	594.0
10SV8GH4F80	2	14.50	17.24	28.17	25.77	8.89	48.25	23.24	27.52	640.0
10SV11GJ4F80	2	14.50	17.24	28.17	25.77	8.89	54.13	42.84	27.52	757.3

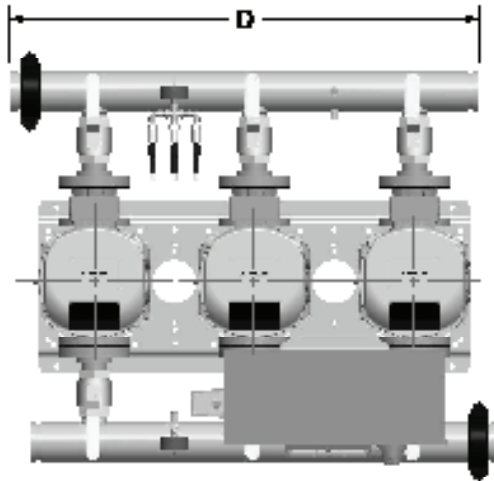

460V  
AquaForce e-HV Dimensions 10SV - 3 Pump

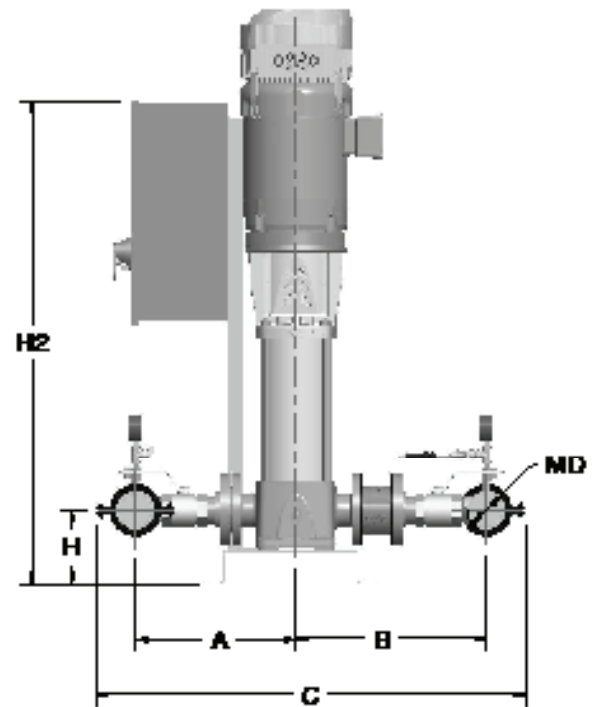
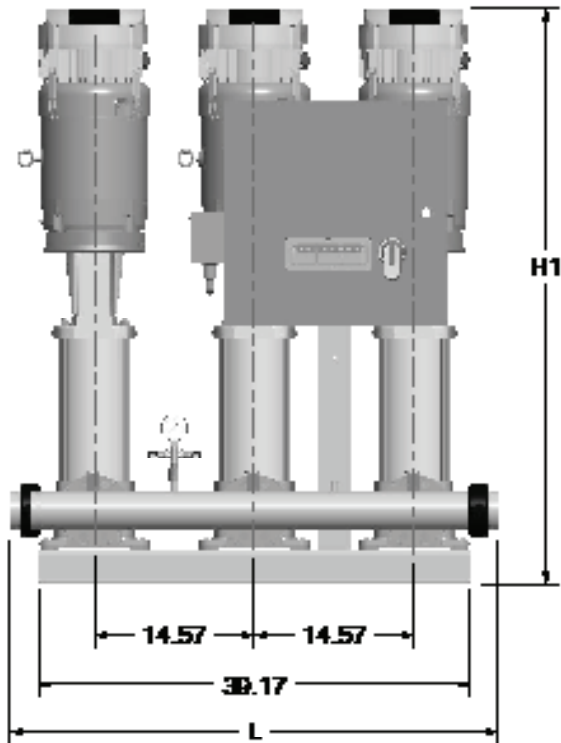

HVL303	MD	A	B	C	D	H	H1	H2	L	Wt. (lb)
10SV2GE4F80	2	14.58	17.24	29.17	42.70	6.80	27.78	23.24	44.45	634.2
10SV3GF4F80	2	14.58	17.24	29.17	42.70	6.80	40.25	23.24	44.45	678.1
10SV8GG4C80	2	14.58	17.24	29.17	42.70	6.80	45.08	23.24	44.45	728.8
10SV8GH4F80	2	14.58	17.24	29.17	42.70	6.80	40.25	23.24	44.45	888.8
10SV11G.14F80	2	14.58	17.24	29.17	42.70	6.80	54.12	43.84	44.45	1044.8

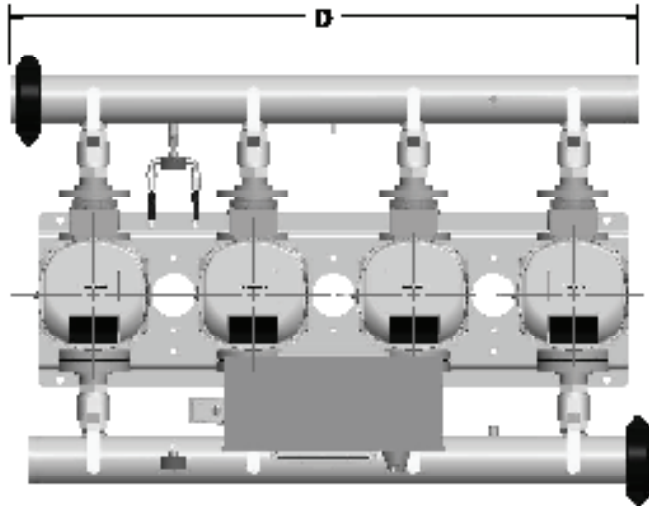

460V  
AquaForce e-HV Dimensions 10SV - 4 Pump

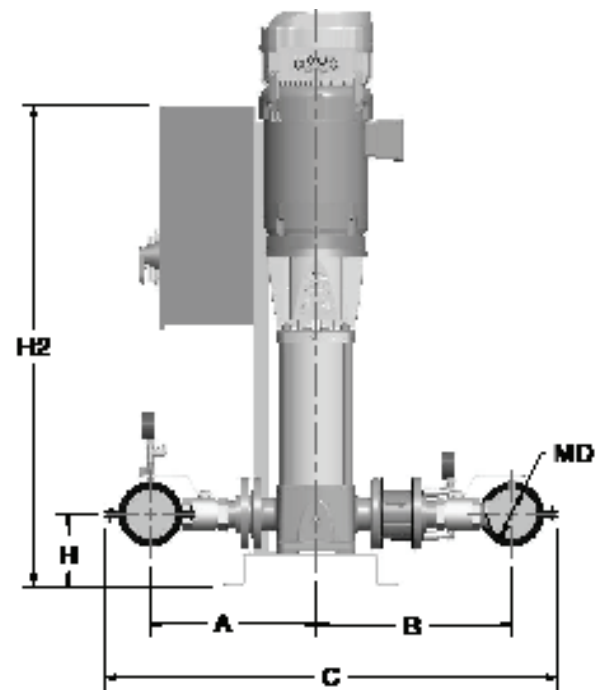
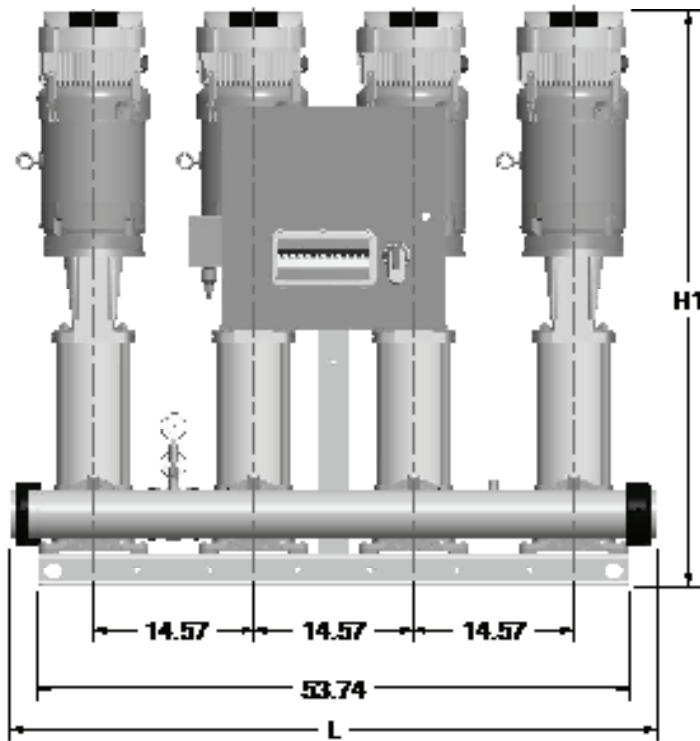

HVL403	MD	A	B	C	D	H	H1	H2	L	Wt.(lb)
10GV2GE4F80	2	14.50	17.24	20.18	55.29	6.89	27.78	23.24	57.04	842.1
10GV3GF4F80	2	14.50	17.24	20.18	55.29	6.89	40.25	23.24	57.04	808.8
10GV8GG4C80	2	14.50	17.24	20.18	55.29	6.89	45.86	23.24	57.04	1080.8
10GV8GH4F80	2	14.50	17.24	20.18	55.29	6.89	49.25	23.24	57.04	1152.8
10GV11GJ4F80	2	14.50	17.24	20.18	55.29	6.89	54.13	43.84	57.04	1287.5

HVL404	MD	A	B	C	D	H	H1	H2	L	Wt.(lb)
10GV2GE4F80	4	15.09	17.84	41.20	57.28	6.89	27.78	23.24	59.01	1008.0
10GV3GF4F80	4	15.09	17.84	41.20	57.28	6.89	40.25	23.24	59.01	1067.8
10GV8GG4C80	4	15.09	17.84	41.20	57.28	6.89	45.86	23.24	59.01	1228.8
10GV8GH4F80	4	15.09	17.84	41.20	57.28	6.89	49.25	23.24	59.01	1320.8
10GV11GJ4F80	4	15.09	17.84	41.20	57.28	6.89	54.13	42.84	59.01	1555.4

# AquaForce e-HV Curves 15SV

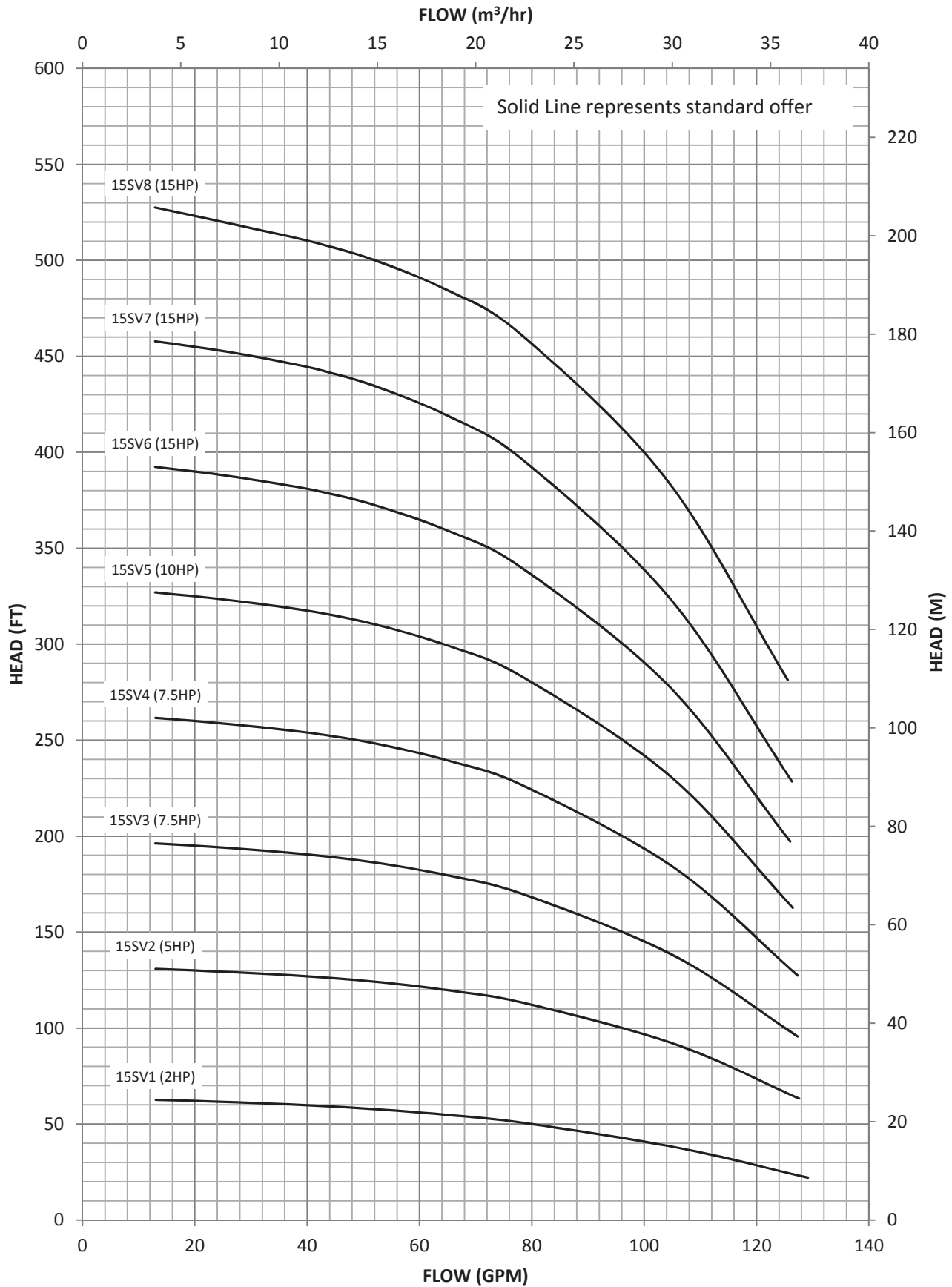



# AquaForce e-HV Curves 15SV

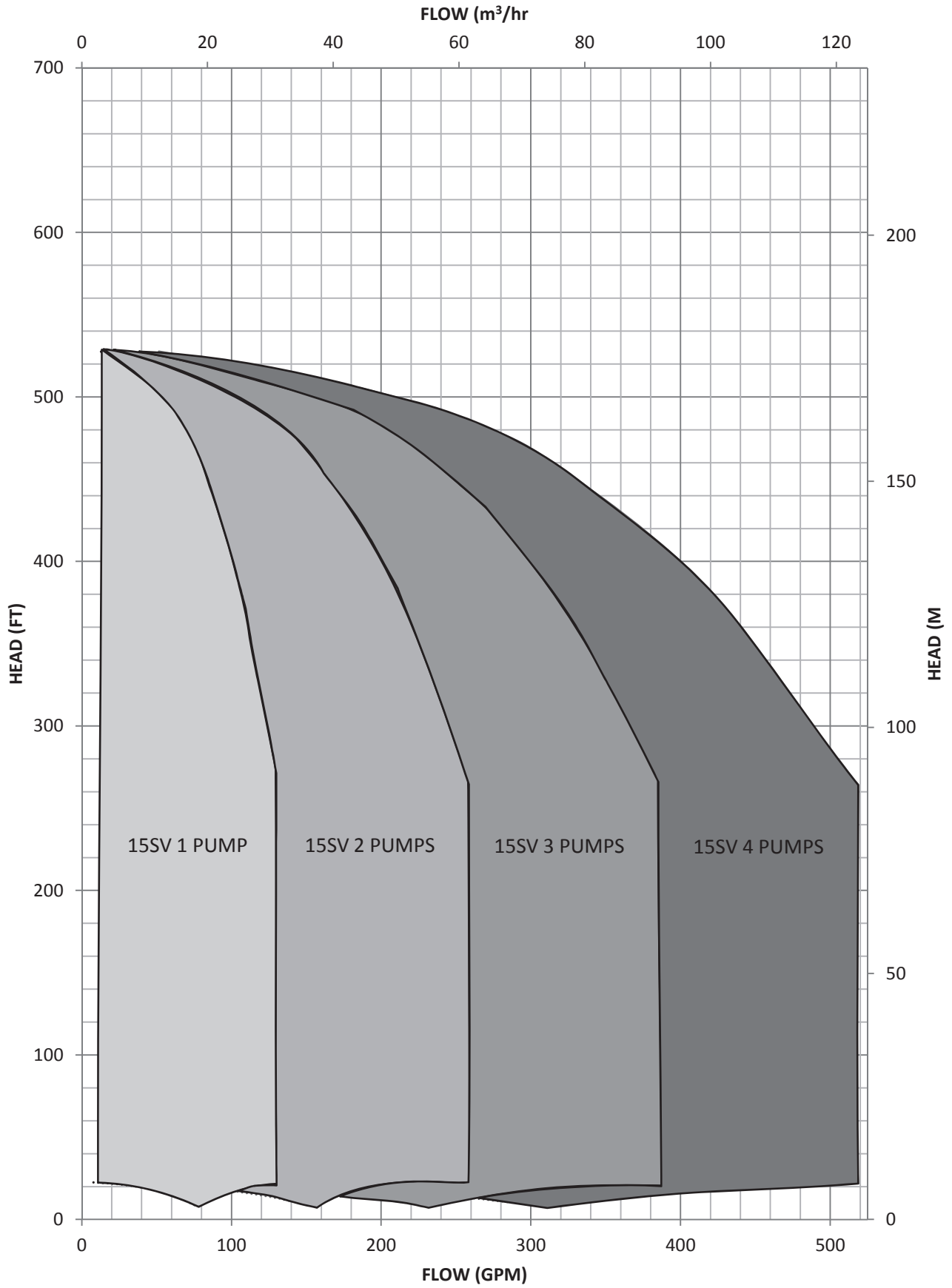

208-230V  
AquaForce e-HV Dimensions 15SV - 2 Pump

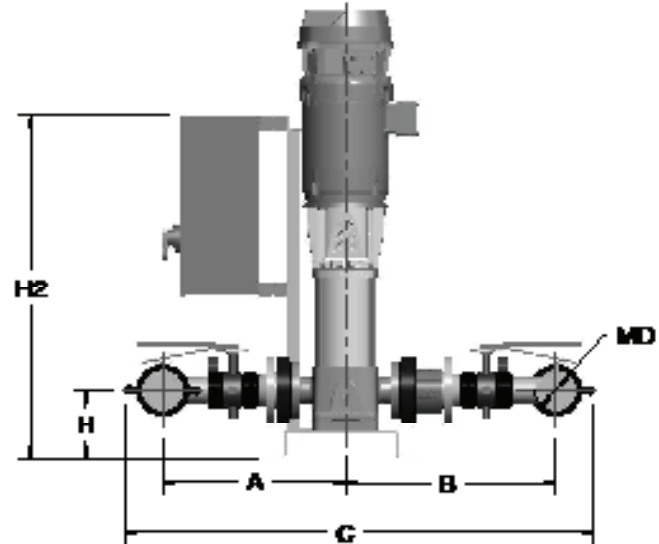
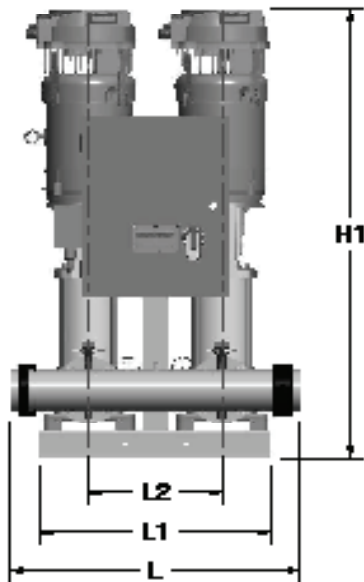
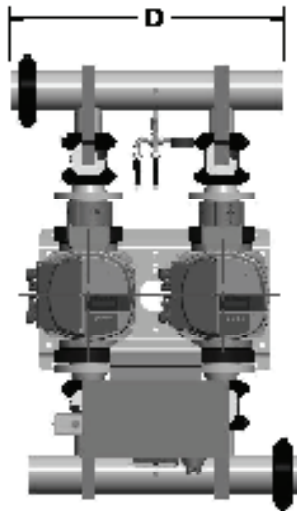

HVL2L3	MD	A	B	C	D	H	H1	H2	L	L1	L2	Wt. (lb)
156V1GE4F80	2	18.47	22.47	48.18	28.67	7.68	40.62	28.34	25.62	25.20	14.57	508.8
156V2GG4C80	2	18.47	22.47	48.18	28.67	7.68	45.32	28.34	25.62	25.20	14.57	755.8
156V3GH4F80	2	18.47	22.47	48.18	28.67	7.68	47.28	28.34	25.62	25.20	14.57	852.0
156V4GH4F80	2	18.47	22.47	48.18	28.67	7.68	48.18	28.34	25.62	25.20	14.57	858.8
156V5G4MF80	2	18.47	22.47	48.18	28.43	8.67	54.63	28.52	42.12	42.12	21.28	1058.8
156V6GK4F80	2	18.47	22.47	48.18	28.43	8.87	58.98	45.02	42.12	42.12	21.28	1285.4
156V7GK4F80	2	18.47	22.47	48.18	28.43	8.87	62.50	45.02	42.12	42.12	21.28	1402.8
156V8GK4F80	2	18.47	22.47	48.18	28.43	8.87	64.28	45.02	42.12	42.12	21.28	1428.4
HVL2L4	MD	A	B	C	D	H	H1	H2	L	L1	L2	Wt. (lb)
155V1GE4F80	4	18.97	22.97	51.32	29.67	7.80	40.62	28.24	25.62	25.20	14.57	812.7
155V2GG4C80	4	18.97	22.97	51.32	29.67	7.80	45.22	28.24	25.62	25.20	14.57	788.8
155V3GH4F80	4	18.97	22.97	51.32	29.67	7.80	47.28	28.24	25.62	25.20	14.57	862.9
155V4GH4F80	4	18.97	22.97	51.32	29.67	7.80	49.18	28.24	25.62	25.20	14.57	870.8
155V5G4MF80	4	18.97	22.97	51.32	28.48	8.87	54.63	45.02	42.12	42.12	21.28	1074.4
155V6GK4F80	4	18.97	22.97	51.32	28.48	8.87	58.88	45.02	42.12	42.12	21.28	1401.0
155V7GK4F80	4	18.97	22.97	51.32	28.48	8.87	62.50	45.02	42.12	42.12	21.28	1418.4
155V8GK4F80	4	18.97	22.97	51.32	28.48	8.87	64.28	45.02	42.12	42.12	21.28	1424.0

208-230V  
AquaForce e-HV Dimensions 15SV - 3 Pump

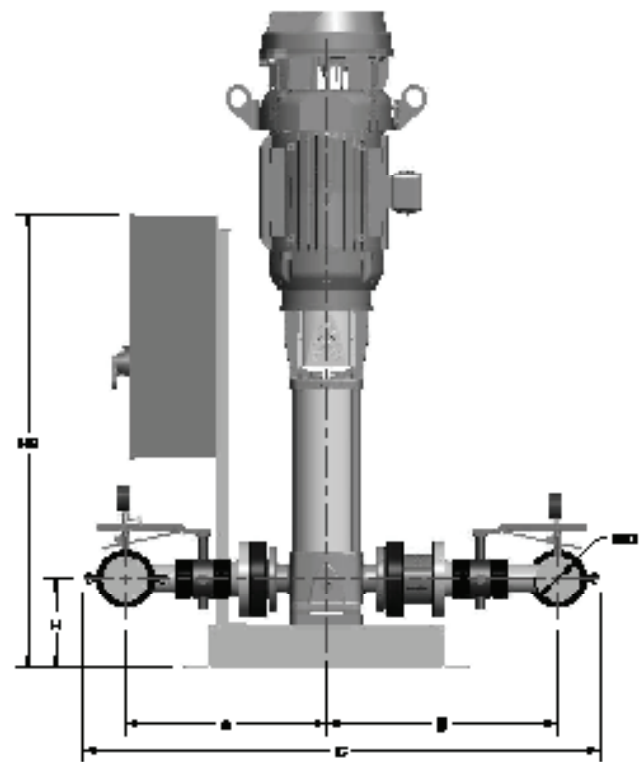
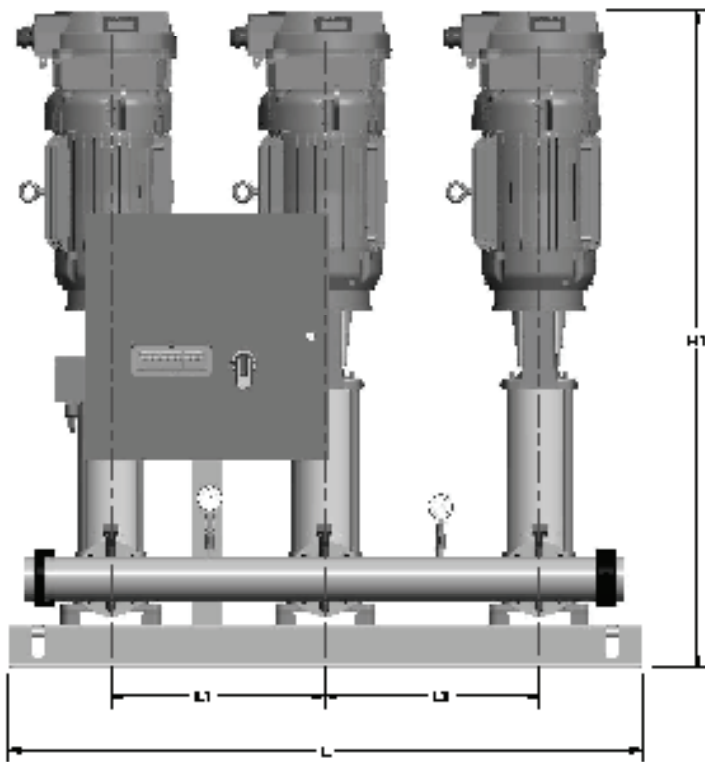
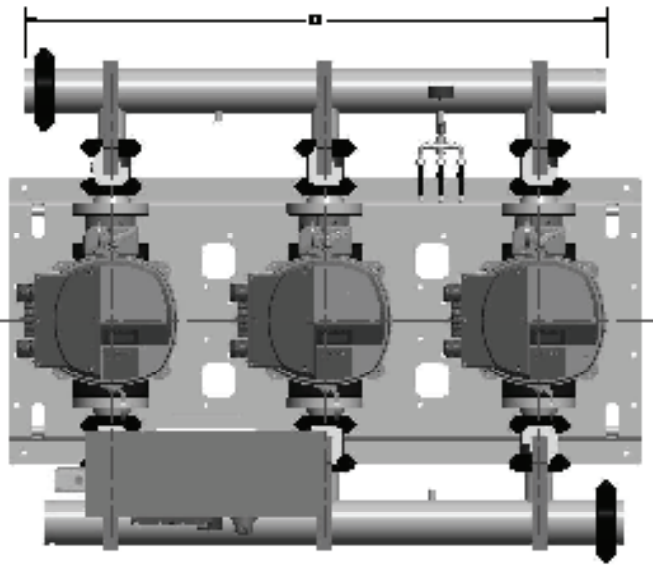

HVL3L4	MD	A	B	C	D	H	H1	H2	L	L1	Wt.(lb)
15SV1GE4F80	4	18.87	22.87	51.32	44.27	7.89	40.62	28.24	50.12	14.57	882.5
15SV2GG4F80	4	18.87	22.87	51.32	44.27	7.89	45.22	28.24	50.12	14.57	1128.1
15SV3GH4F80	4	18.87	22.87	51.32	44.27	7.89	47.29	28.24	50.12	14.57	1288.4
15SV4GH4F80	4	18.87	22.87	51.32	44.27	7.89	48.18	28.24	50.12	14.57	1278.7
15SV5GJ4F80	4	18.87	22.87	51.32	57.75	7.89	54.63	45.02	62.62	21.28	1823.5
15SV8GK4F80	4	18.87	22.87	51.32	57.75	8.87	58.86	45.02	62.62	21.28	2078.9
15SV7GK4F80	4	18.87	22.87	51.32	57.75	8.87	62.50	45.02	62.62	21.28	2108.5
15SV8GK4F80	4	18.87	22.87	51.32	57.75	8.87	64.29	45.02	62.62	21.28	2112.4

208-230V  
AquaForce e-HV Dimensions 15SV - 4 Pump

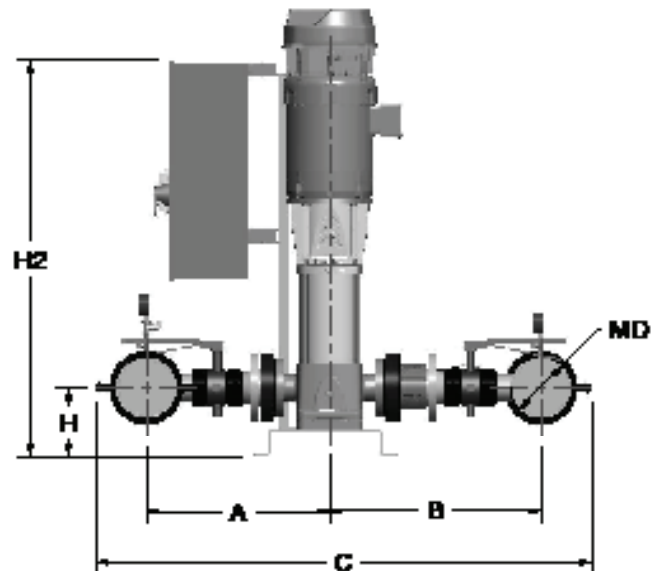
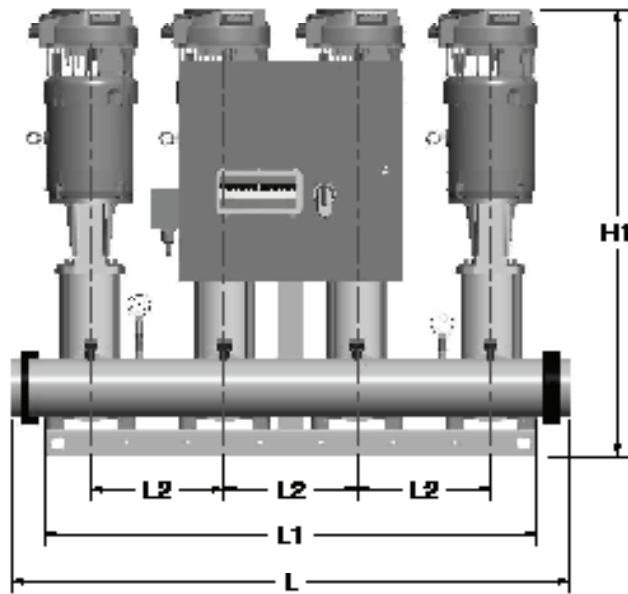
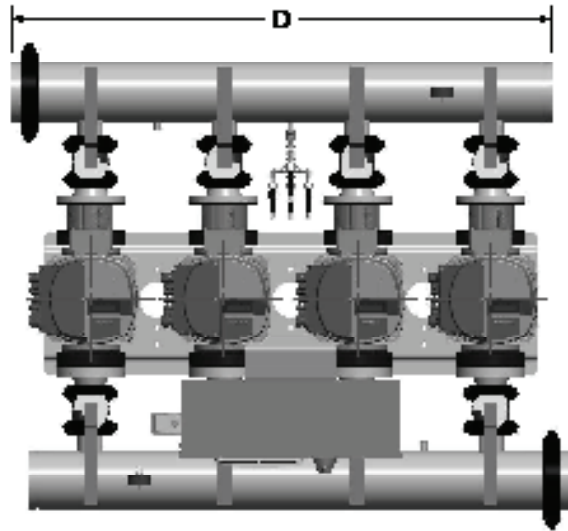

HVL4L4	MD	A	B	C	D	H	H1	H2	L	L1	L2	Wt.(lb)
156V1GE4F80	4	18.87	22.97	51.32	57.35	7.68	40.02	28.34	64.75	53.74	14.57	1185.2
156V2GG4F80	4	18.87	22.97	51.32	57.35	7.68	45.32	28.34	64.75	53.74	14.57	1482.7
156V3GH4F80	4	18.87	22.97	51.32	57.35	7.68	47.28	28.34	64.75	53.74	14.57	1727.2
156V4GH4F80	4	18.87	22.97	51.32	57.35	7.68	48.18	43.84	64.75	53.74	14.57	1741.1
156V5GJ4F80	4	18.87	22.97	51.32	77.43	8.87	54.02	45.02	85.82	85.82	14.57	2127.0
156V8GK4F80	4	18.87	22.97	51.32	77.43	8.87	58.98	50.02	85.82	85.82	21.28	2781.5
156V7GK4F80	4	18.87	22.97	51.32	77.43	8.87	62.50	50.02	85.82	85.82	21.28	2818.2
156V8GK4F80	4	18.87	22.97	51.32	77.43	8.87	64.38	50.02	85.82	85.82	21.28	2827.5
HVL4L8	MD	A	B	C	D	H	H1	H2	L	L1	L2	Wt.(lb)
156V1GE4F80	8	20.02	23.02	54.18	58.08	7.68	40.02	28.34	64.75	53.74	14.57	1215.4
156V2GG4F80	8	20.02	23.02	54.18	58.08	7.68	45.32	28.34	64.75	53.74	14.57	1522.7
156V3GH4F80	8	20.02	23.02	54.18	58.08	7.68	47.28	28.34	64.75	53.74	14.57	1777.2
156V4GH4F80	8	20.02	23.02	54.18	58.08	7.68	48.18	43.84	64.75	53.74	14.57	1781.1
156V5GJ4F80	8	21.02	24.02	58.18	78.12	8.87	54.02	45.02	85.82	85.82	21.28	2255.5
156V8GK4F80	8	21.02	24.02	58.18	78.12	8.87	58.98	50.02	85.82	85.82	21.28	2850.0
156V7GK4F80	8	21.02	24.02	58.18	78.12	8.87	62.50	50.02	85.82	85.82	21.28	2888.8
156V8GK4F80	8	21.02	24.02	58.18	78.12	8.87	64.38	50.02	85.82	85.82	21.28	2898.0

460V  
AquaForce e-HV Dimensions 15SV - 2 Pump

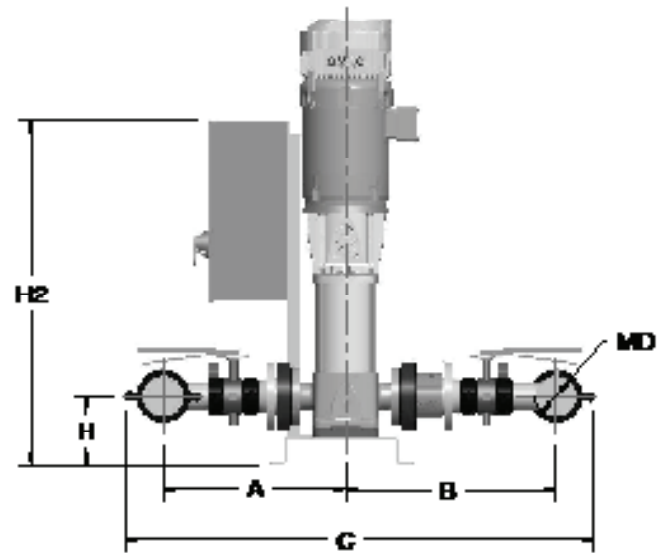
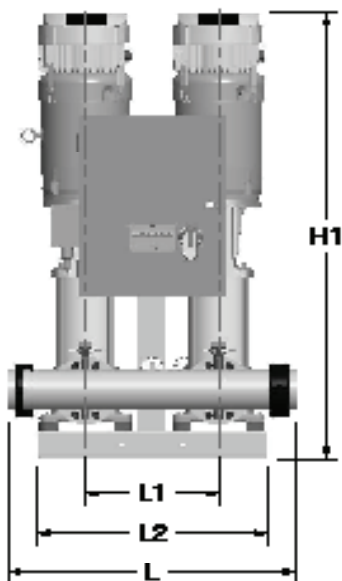
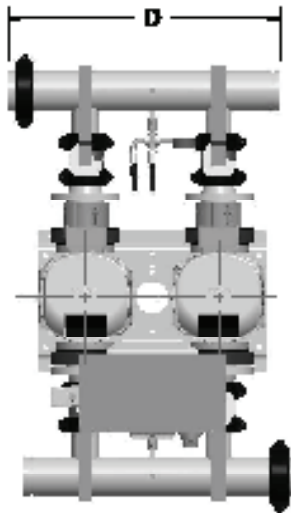

HVL2D3	MD	A	B	C	D	H	H1	H2	L	L1	L2	Wt.(lb)
156V1GE4F80	2	18.47	22.47	48.18	28.70	7.68	40.81	28.34	25.63	14.57	25.20	842.7
156V2GG4C80	2	18.47	22.47	48.18	28.70	7.68	43.58	28.34	25.63	14.57	25.20	738.3
156V3GH4F80	2	18.47	22.47	48.18	28.70	7.68	48.75	28.34	25.63	14.57	25.20	748.2
156V4GH4F80	2	18.47	22.47	48.18	28.70	7.68	48.63	28.34	25.63	14.57	25.20	788.8
156V5GJ4F80	2	18.47	22.47	48.18	28.70	7.68	52.25	28.34	25.63	14.57	25.20	895.7
156V6GK4F80	2	18.47	22.47	48.18	22.48	8.87	58.82	45.02	28.28	17.22	27.80	1187.8
156V7GK4F80	2	18.47	22.47	48.18	22.48	8.87	62.34	45.02	28.28	17.22	27.80	1188.0
156V8GK4F80	2	18.47	22.47	48.18	22.48	8.87	64.23	45.02	28.28	17.22	27.80	1188.8
HVL2D4	MD	A	B	C	D	H	H1	H2	L	L1	L2	Wt.(lb)
156V1GE4F80	4	18.97	22.97	51.32	28.70	7.80	40.81	28.34	25.63	14.57	25.20	728.5
156V2GG4C80	4	18.97	22.97	51.32	28.70	7.80	43.58	28.34	25.63	14.57	25.20	825.1
156V3GH4F80	4	18.97	22.97	51.32	28.70	7.80	48.75	28.34	25.63	14.57	25.20	822.0
156V4GH4F80	4	18.97	22.97	51.32	28.70	7.80	48.63	28.34	25.63	14.57	25.20	875.7
156V5GJ4F80	4	18.97	22.97	51.32	28.70	7.80	52.25	28.34	25.63	14.57	25.20	881.5
156V6GK4F80	4	18.97	22.97	51.32	22.48	8.87	58.82	45.02	28.28	17.22	27.80	1182.1
156V7GK4F80	4	18.97	22.97	51.32	22.48	8.87	62.34	45.02	28.28	17.22	27.80	1200.5
156V8GK4F80	4	18.97	22.97	51.32	22.48	8.87	64.23	45.02	28.28	17.22	27.80	1205.1

460V  
AquaForce e-HV Dimensions 15SV - 3 Pump

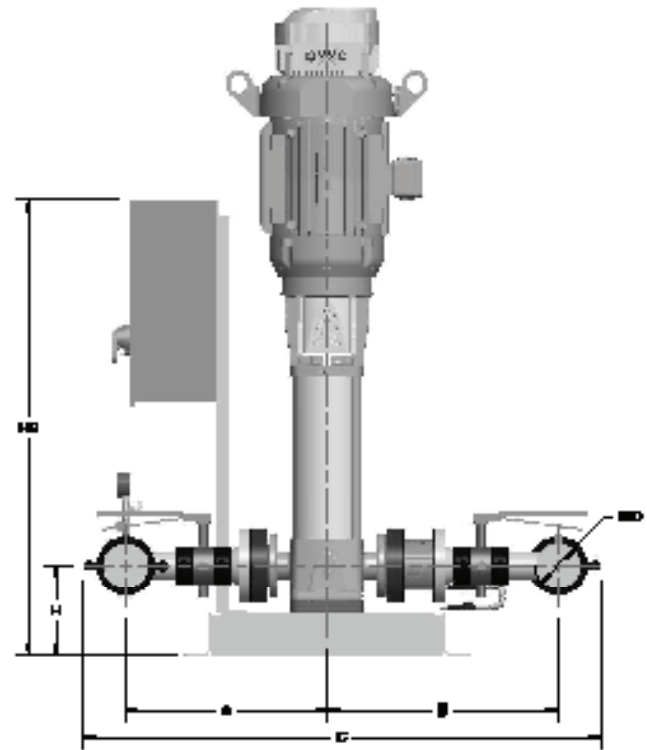
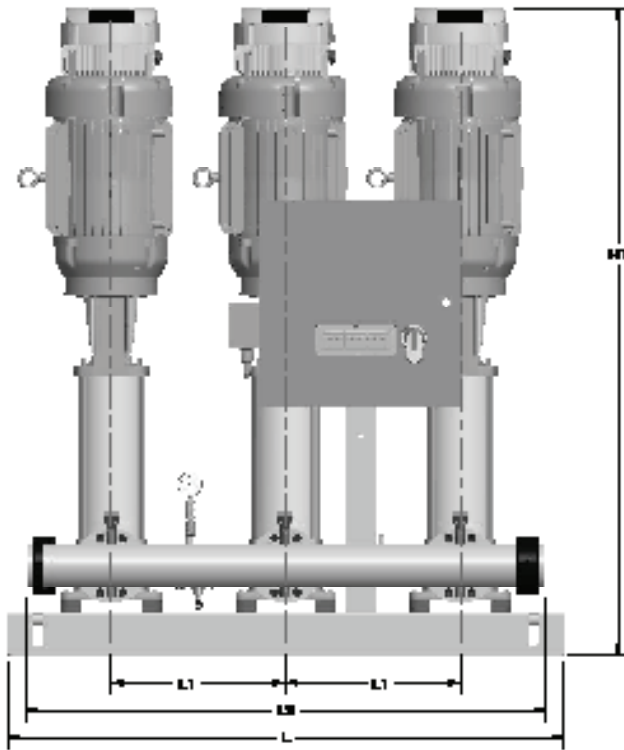
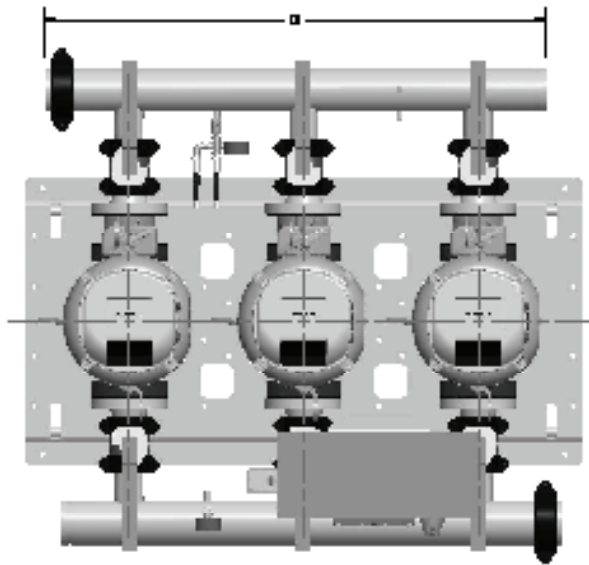

HVL3D4	MD	A	B	C	D	H	H1	H2	L	L1	L2	Wt.(lb)
15SV1GE4F80	4	18.97	22.97	51.32	44.27	7.60	40.81	28.24	50.13	14.57	40.02	898.1
15SV2GG4C80	4	18.97	22.97	51.32	44.27	7.60	43.58	28.24	50.13	14.57	40.02	1101.5
15SV3GH4F80	4	18.97	22.97	51.32	44.27	7.60	46.75	28.24	50.13	14.57	40.02	1148.7
15SV4GH4F80	4	18.97	22.97	51.32	44.27	7.60	48.60	28.24	50.13	14.57	40.02	1158.1
15SV5GJ4F80	4	18.97	22.97	51.32	44.27	7.60	52.25	28.24	50.13	14.57	40.02	1275.2
15SV6GK4F80	4	18.97	22.97	51.32	49.78	8.87	50.82	45.02	55.60	17.22	51.53	1888.5
15SV7GK4F80	4	18.97	22.97	51.32	49.78	8.87	62.24	45.02	55.60	17.22	51.53	1718.1
15SV8GK4F80	4	18.97	22.97	51.32	49.78	8.87	84.23	45.02	55.60	17.22	51.53	1728.0

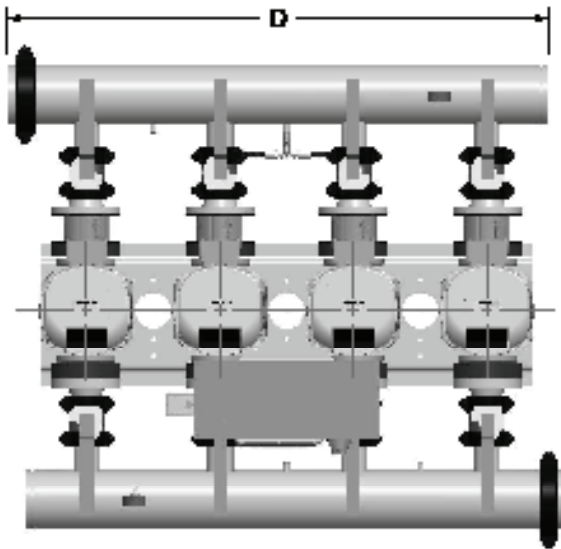

460V  
AquaForce e-HV Dimensions 15SV - 4 Pump

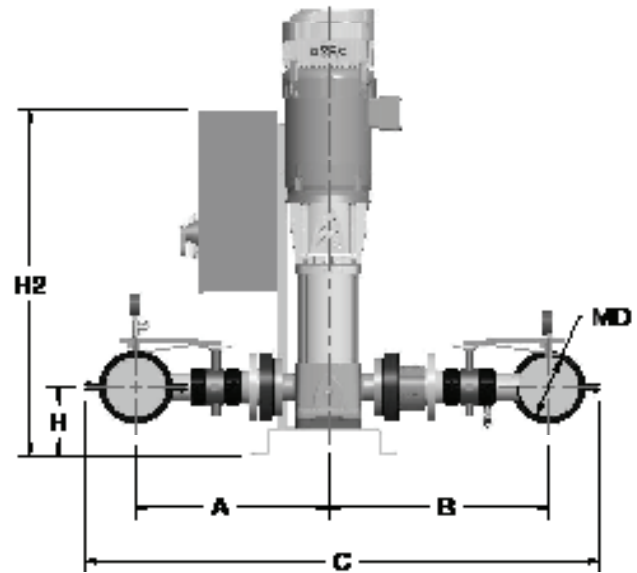
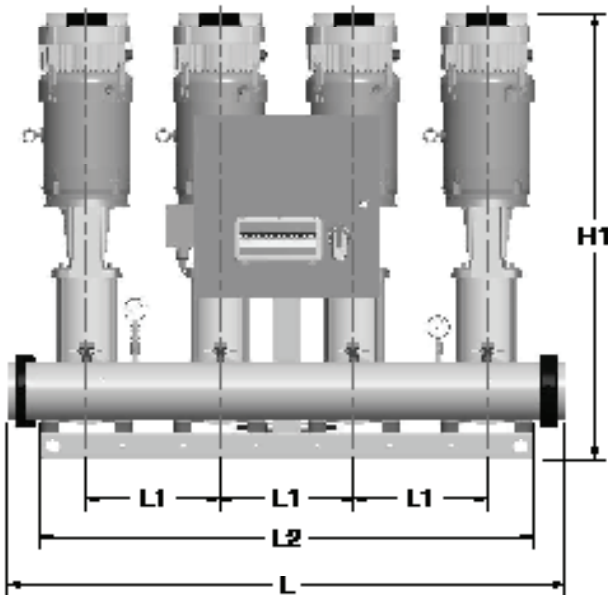

HVL4D4	MD	A	B	C	D	H	H1	H2	L	L1	L2	Wt.(lb)
156V1GE4F80	4	18.87	22.97	51.32	57.26	7.68	40.81	28.34	64.75	14.57	53.74	1175.8
156V2GG4C80	4	18.87	22.97	51.32	57.26	7.68	43.58	28.34	64.75	14.57	53.74	1288.8
156V3GH4F80	4	18.87	22.97	51.32	57.26	7.68	48.75	28.34	64.75	14.57	53.74	1458.2
156V4GH4F80	4	18.87	22.97	51.32	57.26	7.68	48.82	28.34	64.75	14.57	53.74	1470.0
156V5GJ4F80	4	18.87	22.97	51.32	57.26	7.68	52.25	28.34	64.75	14.57	53.74	1681.8
156V8GK4F80	4	18.87	22.97	51.32	65.52	8.87	58.82	45.02	74.01	17.22	74.01	2248.8
156V7GK4F80	4	18.87	22.97	51.32	65.52	8.87	62.34	45.02	74.01	17.22	74.01	2288.7
156V8GK4F80	4	18.87	22.97	51.32	65.52	8.87	64.23	45.02	74.01	17.22	74.01	2285.8
HVL4D6	MD	A	B	C	D	H	H1	H2	L	L1	L2	Wt.(lb)
156V1GE4F80	6	21.02	24.02	58.18	58.96	7.68	40.81	28.34	64.75	14.57	53.74	1220.0
156V2GG4C80	6	21.02	24.02	58.18	58.96	7.68	43.58	28.34	64.75	14.57	53.74	1422.2
156V3GH4F80	6	21.02	24.02	58.18	58.96	7.68	48.75	28.34	64.75	14.57	53.74	1510.8
156V4GH4F80	6	21.02	24.02	58.18	58.96	7.68	48.82	28.34	64.75	14.57	53.74	1524.4
156V5GJ4F80	6	21.02	24.02	58.18	58.96	7.68	52.25	28.34	64.75	14.57	53.74	1728.0
156V8GK4F80	6	21.02	24.02	58.18	67.22	8.87	58.82	45.02	74.01	17.22	74.01	2210.1
156V7GK4F80	6	21.02	24.02	58.18	67.22	8.87	62.34	45.02	74.01	17.22	74.01	2248.8
156V8GK4F80	6	21.02	24.02	58.18	67.22	8.87	64.23	45.02	74.01	17.22	74.01	2258.1

# AquaForce e-HV Curves 33SV

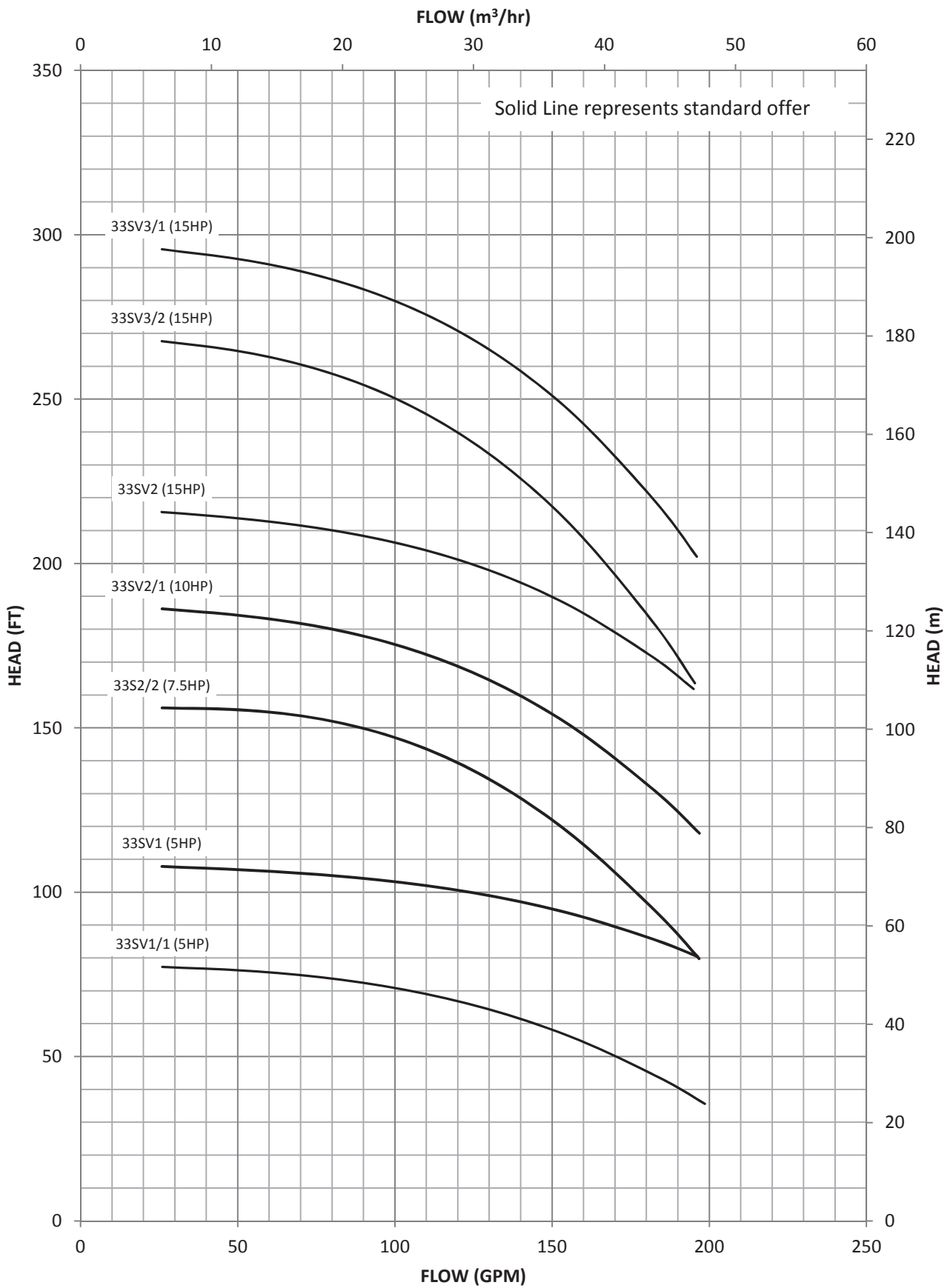



AquaForce e-HV Curves 33SV

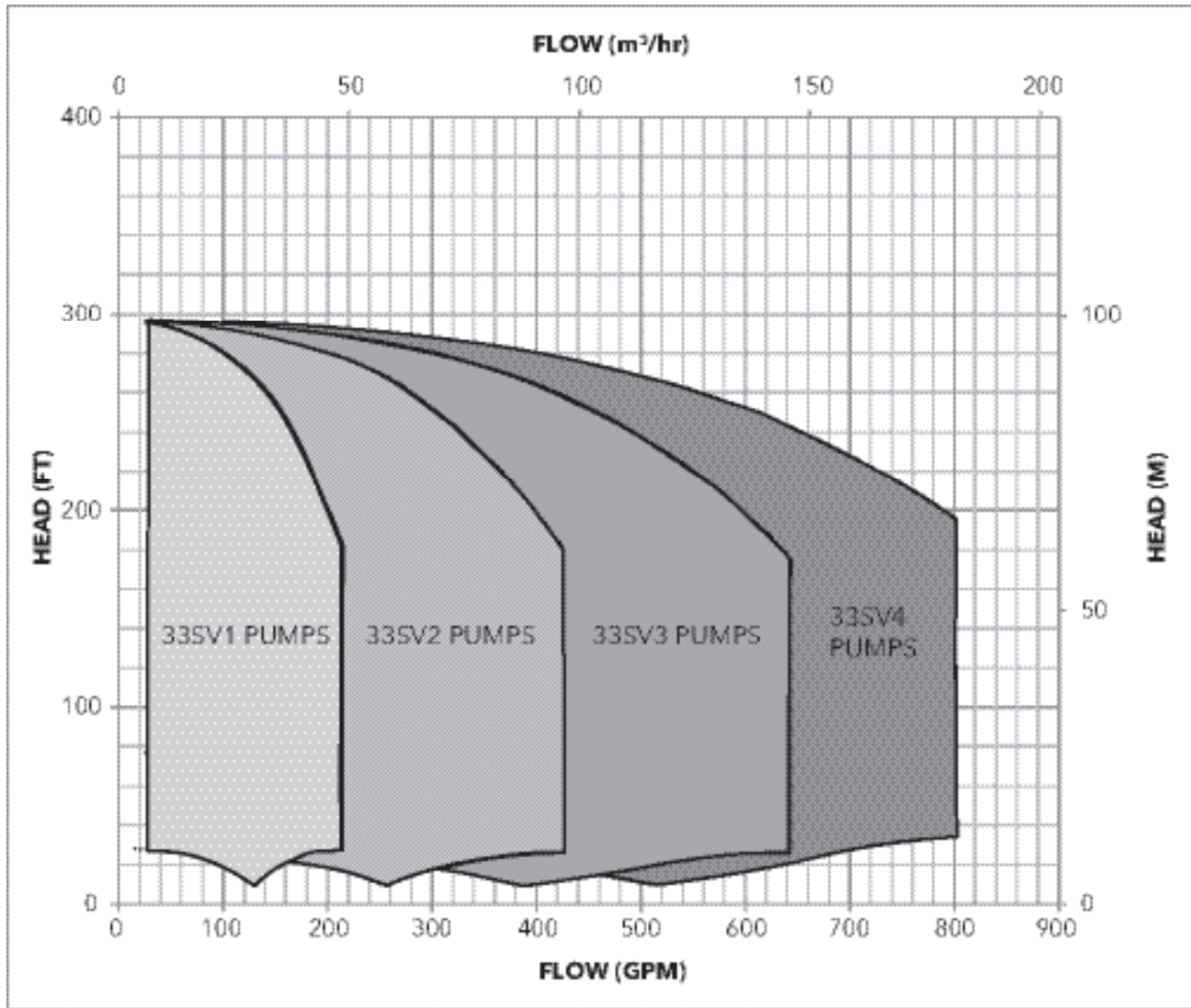

208-230V  
AquaForce e-HV Dimensions 33SV - 2 Pump

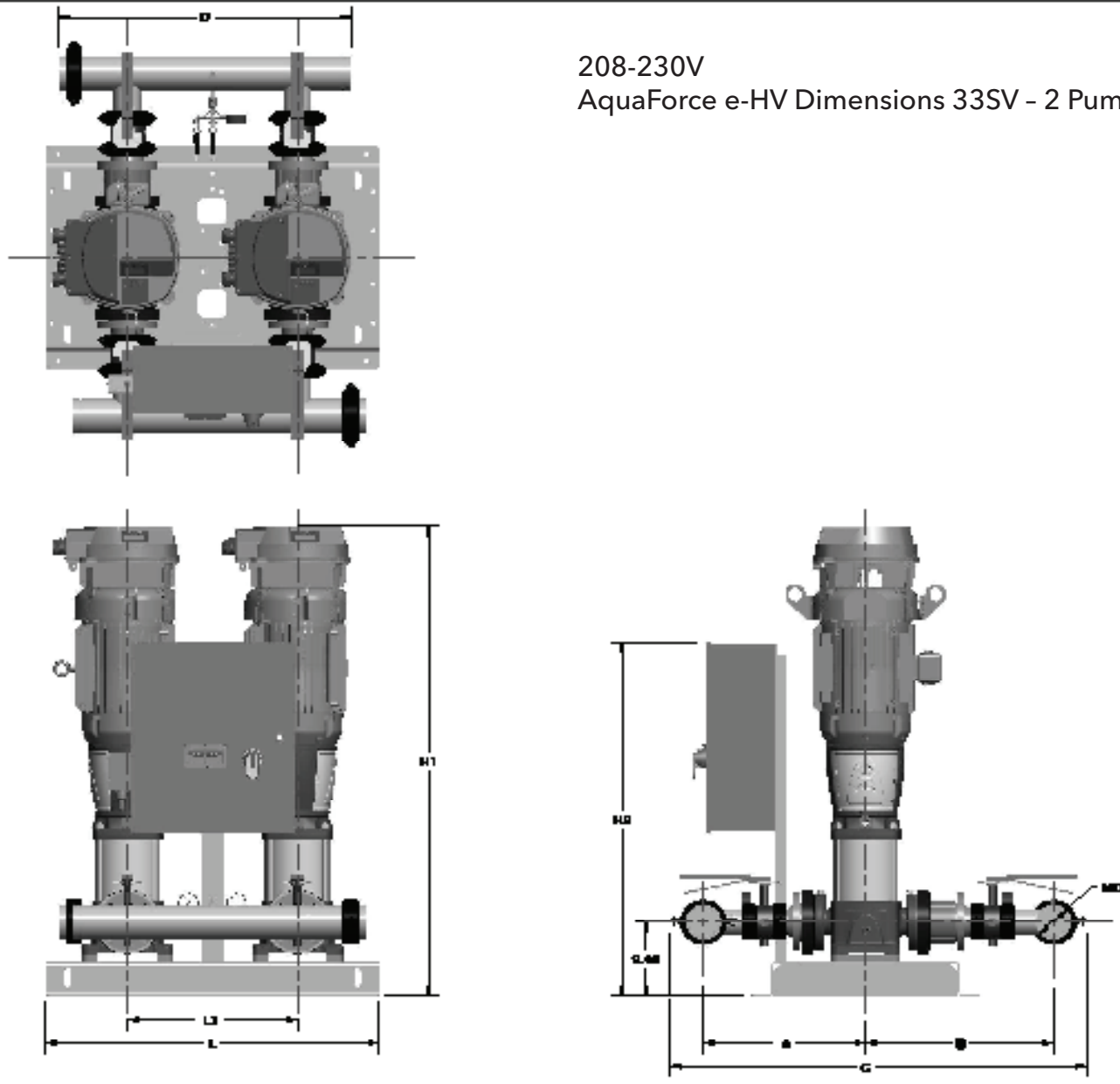

HVL2L3	MD	A	B	C	D	H1	H2	L	L1	Wt. (lbs)
335V11GG4F80	3	18.74	22.89	48.97	22.48	48.41	29.52	28.28	17.22	1077.9
335V10GH4F80	3	18.74	22.89	48.97	22.48	48.48	29.52	28.28	17.22	1184.6
335V22GH4F80	3	18.74	22.89	48.97	22.48	51.45	29.52	28.28	17.22	1180.9
335V21GJ4F80	3	18.74	22.89	48.97	28.40	53.28	29.52	42.28	21.28	1280.7
335V20GK4F80	3	18.74	22.89	48.97	28.40	58.70	45.02	42.28	21.28	1801.2
335V32GK4F80	3	18.74	22.89	48.97	28.40	59.68	45.02	42.28	21.28	1821.9
335V31GK4F80	3	18.74	22.89	48.97	28.40	59.68	45.02	42.28	21.28	1821.9

HVL2L4	MD	A	B	C	D	H1	H2	L	L1	Wt. (lbs)
335V11GG4F80	4	20.24	23.48	52.10	22.55	48.41	29.52	28.28	17.22	1082.6
335V10GH4F80	4	20.24	23.48	52.10	22.55	48.48	29.52	28.28	17.22	1179.2
335V22GH4F80	4	20.24	23.48	52.10	22.55	51.45	29.52	28.28	17.22	1204.6
335V21GJ4F80	4	20.24	23.48	52.10	28.48	53.28	29.52	42.28	21.28	1210.5
335V20GK4F80	4	20.24	23.48	52.10	28.48	58.70	45.02	42.28	21.28	1821.0
335V32GK4F80	4	20.24	23.48	52.10	28.48	59.68	45.02	42.28	21.28	1841.7
335V31GK4F80	4	20.24	23.48	52.10	28.48	59.68	45.02	42.28	21.28	1841.7

208-230V  
AquaForce e-HV Dimensions 33SV - 3 Pump

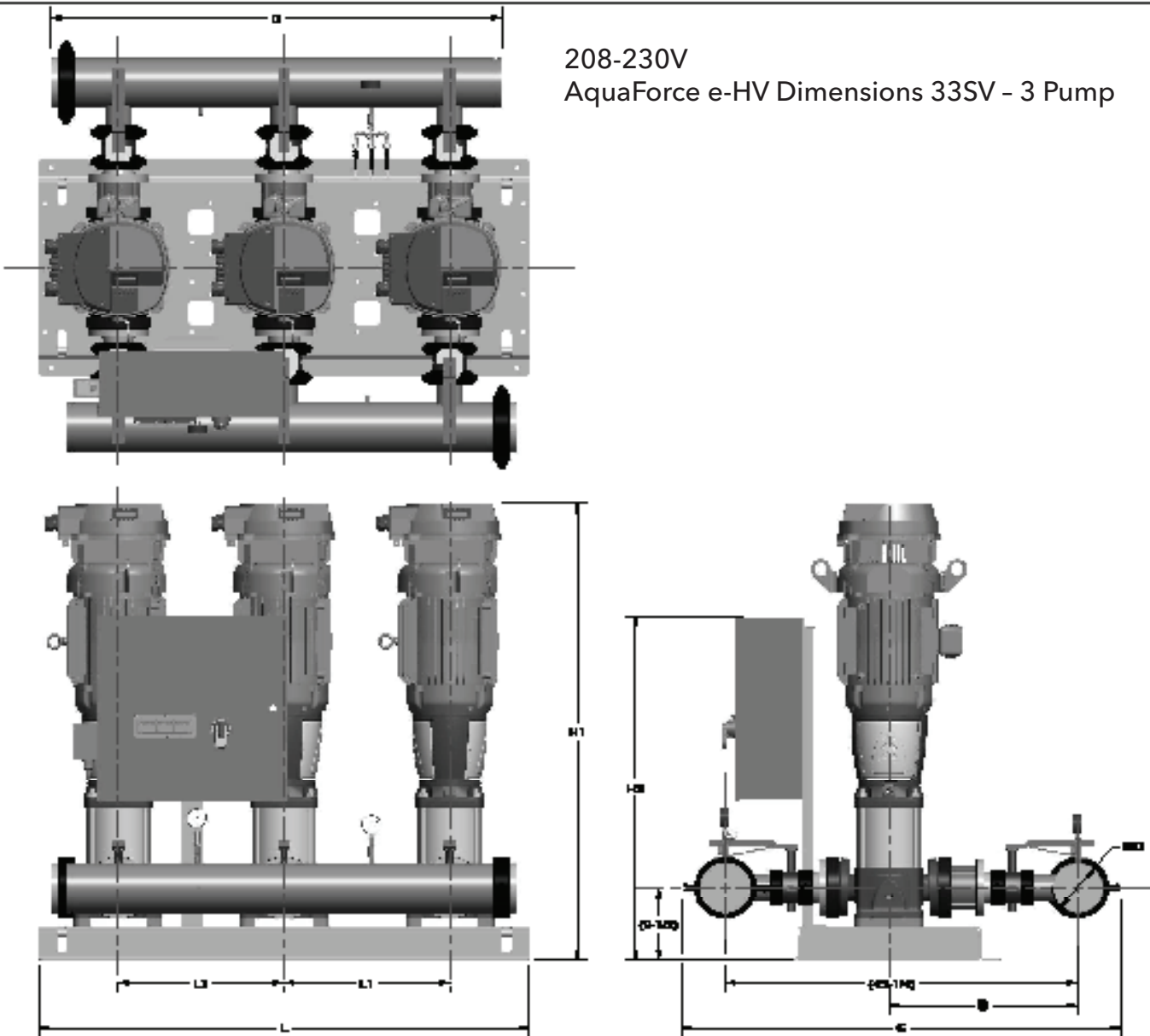

HVL3L4	ND	A	B	C	D	H	H1	H2	L	L1	Wt.(lb)
335V11GG4F80	4	19.82	23.17	51.48	49.78	9.40	48.41	29.52	55.82	17.32	1622.8
335V10GH4F80	4	19.82	23.17	51.48	49.78	9.40	48.48	29.52	55.82	17.32	1751.7
335V22GH4F80	4	19.82	23.17	51.48	49.78	9.40	51.45	29.52	55.82	17.32	1789.8
335V21GJ4F80	4	19.82	23.17	51.48	57.75	9.40	52.26	45.02	83.82	21.28	1972.5
335V20GK4F80	4	19.82	23.17	51.48	57.75	9.40	58.70	45.02	83.82	21.28	2402.8
335V32GK4F80	4	19.82	23.17	51.48	57.75	9.40	58.86	45.02	83.82	21.28	2434.8
335V31GK4F80	4	19.82	23.17	51.48	57.75	9.40	58.86	45.02	83.82	21.28	2434.8

HVL3L8	ND	A	B	C	D	H	H1	H2	L	L1	Wt.(lb)
335V11GG4F80	8	20.89	24.24	58.34	49.81	9.40	48.41	29.52	55.82	17.32	1689.8
335V10GH4F80	8	20.89	24.24	58.34	49.81	9.40	48.48	29.52	55.82	17.32	1787.8
335V22GH4F80	8	20.89	24.24	58.34	49.81	9.40	51.45	29.52	55.82	17.32	1826.7
335V21GJ4F80	8	20.89	24.24	58.34	57.87	9.40	52.26	45.02	83.82	21.28	2024.2
335V20GK4F80	8	20.89	24.24	58.34	57.87	9.40	58.70	45.02	83.82	21.28	2455.5
335V32GK4F80	8	20.89	24.24	58.34	57.87	9.40	58.86	45.02	83.82	21.28	2486.5
335V31GK4F80	8	20.89	24.24	58.34	57.87	9.40	58.86	45.02	83.82	21.28	2486.5

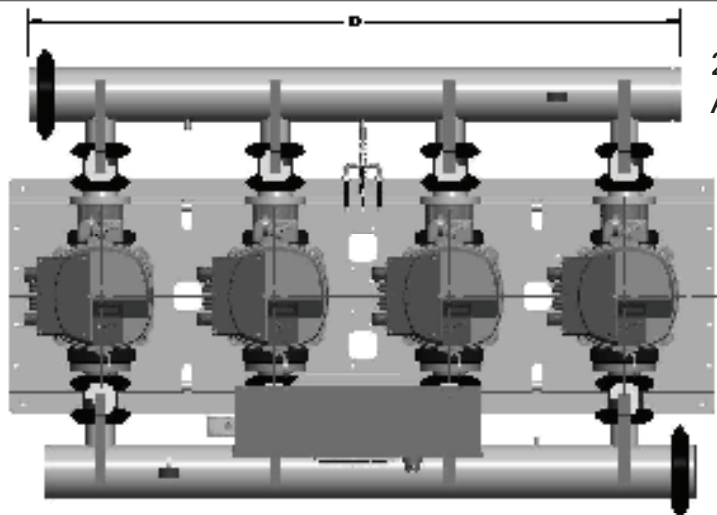

208-230V  
AquaForce e-HV Dimensions 33SV - 4 Pump

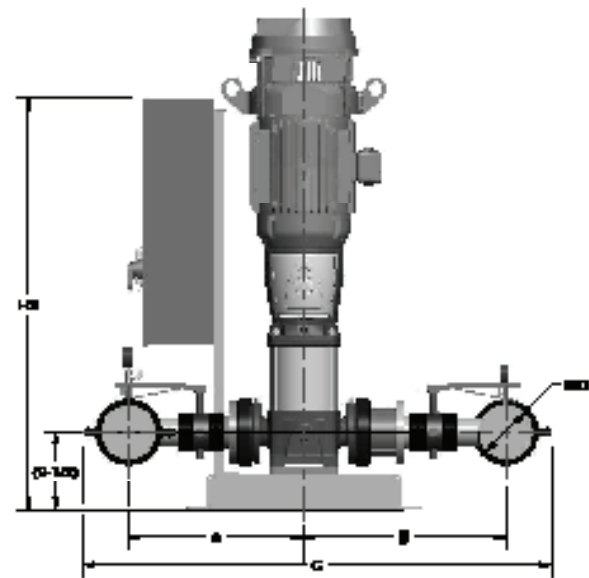
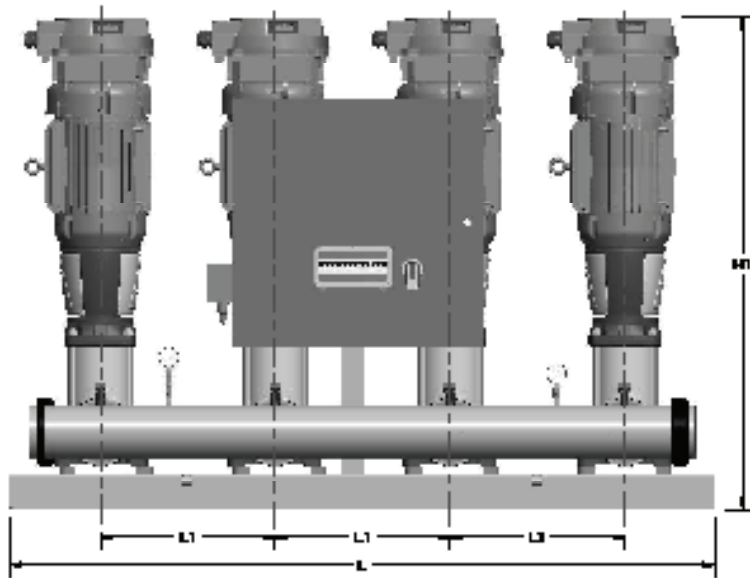

HVL#	MD	A	B	G	D	H	H1	H2	L	L1	Wt.(lb)
336V11GG4F80	■	21.20	24.55	57.00	67.32	9.48	48.41	38.52	74.02	17.22	2208.2
336V10GH4F80	■	21.20	24.55	57.00	67.32	9.48	48.48	45.02	74.02	17.22	2428.0
336V22GH4F80	■	21.20	24.55	57.00	67.32	9.48	51.45	45.02	74.02	17.22	2438.8
336V21GL4F80	■	21.20	24.55	57.00	78.12	9.48	52.28	45.02	85.82	21.26	2868.1
336V20GK4F80	■	21.20	24.55	57.00	78.12	9.48	58.70	50.02	85.82	21.26	3261.4
336V32GK4F80	■	21.20	24.55	57.00	78.12	9.48	58.88	50.02	85.82	21.26	3222.8
336V31GK4F80	■	21.20	24.55	57.00	78.12	9.48	58.88	50.02	85.82	21.26	3222.8

460V  
AquaForce e-HV Dimensions 33SV - 2 Pump

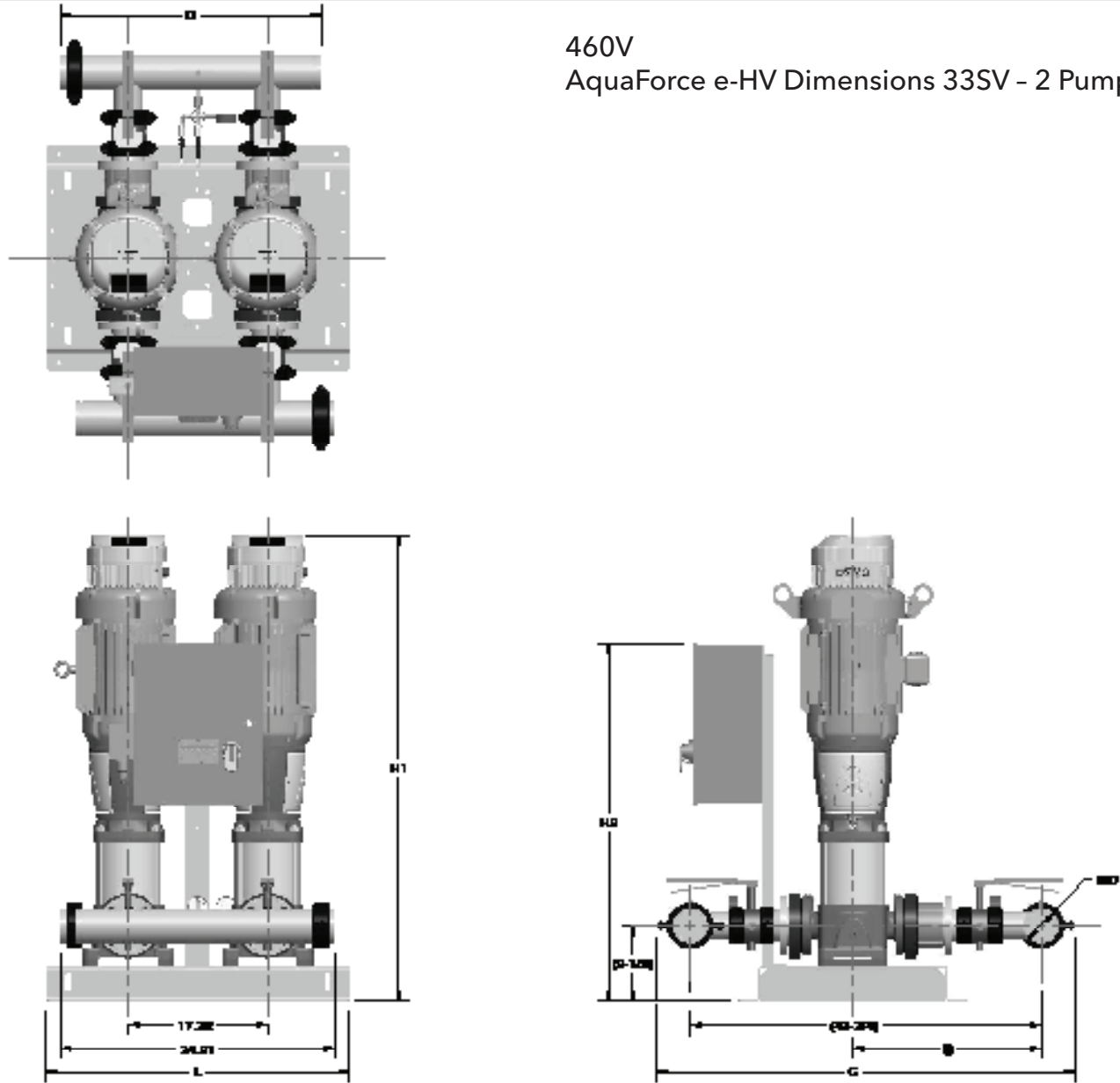

HVL2D3	MD	A	B	C	D	H	H1	H2	L	Wt.(#)
335V11GG4C00	2	22.28	28.81	48.97	22.48	8.48	48.57	45.13	38.25	1053.8
335V10GH4F80	2	22.28	28.81	48.97	22.48	8.48	48.00	45.13	38.25	1080.6
335V22GH4F80	2	22.28	28.81	48.97	22.48	8.48	50.25	45.13	38.25	1113.6
335V21GJ4F80	2	22.28	28.81	48.97	22.48	8.48	52.00	45.13	38.25	1188.7
335V20GK4F80	2	22.28	28.81	48.97	22.48	8.48	55.83	45.13	38.25	1288.8
335V32GK4F80	2	22.28	28.81	48.97	22.48	8.48	58.80	50.83	38.25	1288.8
335V31GK4F80	2	22.28	28.81	48.97	22.48	8.48	58.80	50.83	38.25	1288.8

HVL2D4	MD	A	B	C	D	H	H1	H2	L	Wt.(#)
335V11GG4C00	4	20.24	22.48	52.10	22.48	8.48	48.57	45.13	38.25	1088.5
335V10GH4F80	4	20.24	22.48	52.10	22.48	8.48	48.00	45.12	38.25	1105.2
335V22GH4F80	4	20.24	22.48	52.10	22.48	8.48	50.85	45.12	38.25	1126.2
335V21GJ4F80	4	20.24	22.48	52.10	22.48	8.48	52.00	45.12	38.25	1213.4
335V20GK4F80	4	20.24	22.48	52.10	22.48	8.48	55.83	45.12	38.25	1281.3
335V32GK4F80	4	20.24	22.48	52.10	22.48	8.48	58.80	50.82	38.25	1404.3
335V31GK4F80	4	20.24	22.48	52.10	22.48	8.48	58.80	50.82	38.25	1404.2

460V  
AquaForce e-HV Dimensions 33SV - 3 Pump

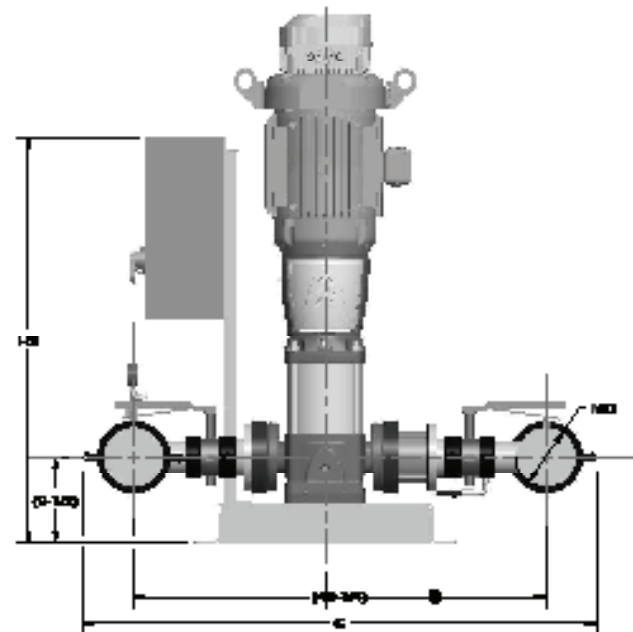
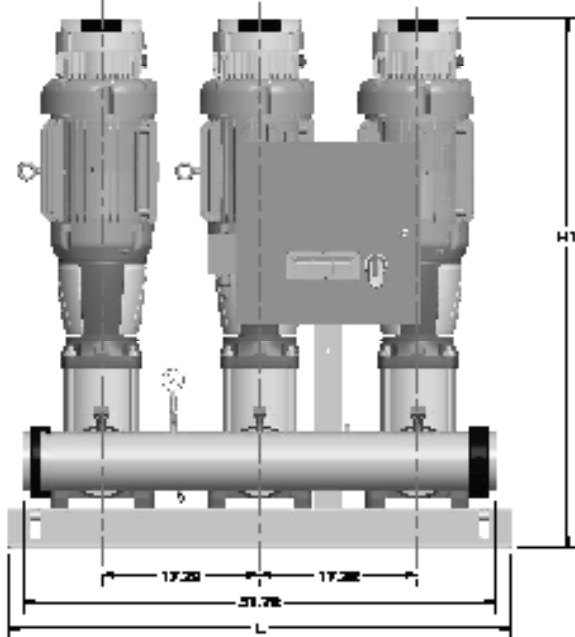
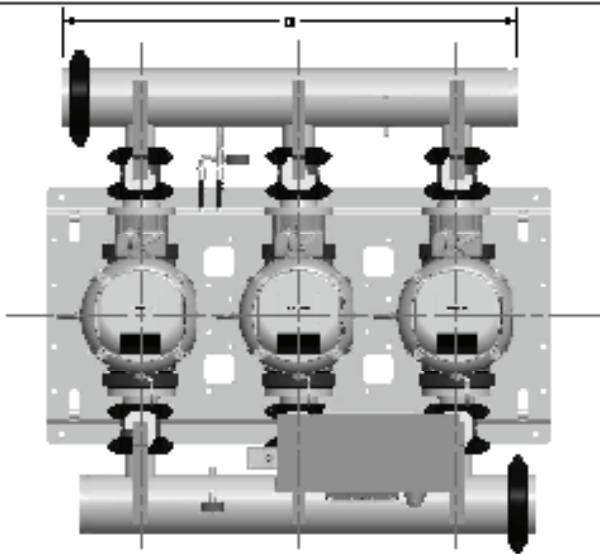

HVL304	MD	A	B	C	D	H	H1	H2	L	Wt. (lb)
335V11GG4G80	4	20.24	22.17	51.78	49.78	8.48	48.57	45.12	55.82	1519.2
335V10GH4F80	4	20.24	22.17	51.78	49.78	8.48	48.00	45.12	55.82	1574.5
335V22GH4F80	4	20.24	22.17	51.78	49.78	8.48	50.88	45.12	55.82	1800.0
335V21GJ4F80	4	20.24	22.17	51.78	49.78	8.48	52.00	45.12	55.82	1728.6
335V20GK4F80	4	20.24	22.17	51.78	49.78	8.48	55.83	45.12	55.82	1988.5
335V32GK4F80	4	20.24	22.17	51.78	49.78	8.48	58.80	50.82	55.82	2023.0
335V31GK4F80	4	20.24	22.17	51.78	49.78	8.48	58.80	50.82	55.82	2023.0

HVL308	MD	A	B	C	D	H	H1	H2	L	Wt. (lb)
335V11GG4G80	8	20.89	24.24	58.34	49.81	8.48	48.57	45.13	55.82	1586.4
335V10GH4F80	8	20.89	24.24	58.34	49.81	8.48	48.00	45.12	55.82	1620.6
335V22GH4F80	8	20.89	24.24	58.34	49.81	8.48	50.88	45.12	55.82	1855.1
335V21GJ4F80	8	20.89	24.24	58.34	49.81	8.48	52.00	45.12	55.82	1782.7
335V20GK4F80	8	20.89	24.24	58.34	49.81	8.48	55.83	45.12	55.82	2024.8
335V32GK4F80	8	20.89	24.24	58.34	49.81	8.48	58.80	50.82	55.82	2080.1
335V31GK4F80	8	20.89	24.24	58.34	49.81	8.48	58.80	50.82	55.82	2080.1

460V  
AquaForce e-HV Dimensions 33SV - 4 Pump

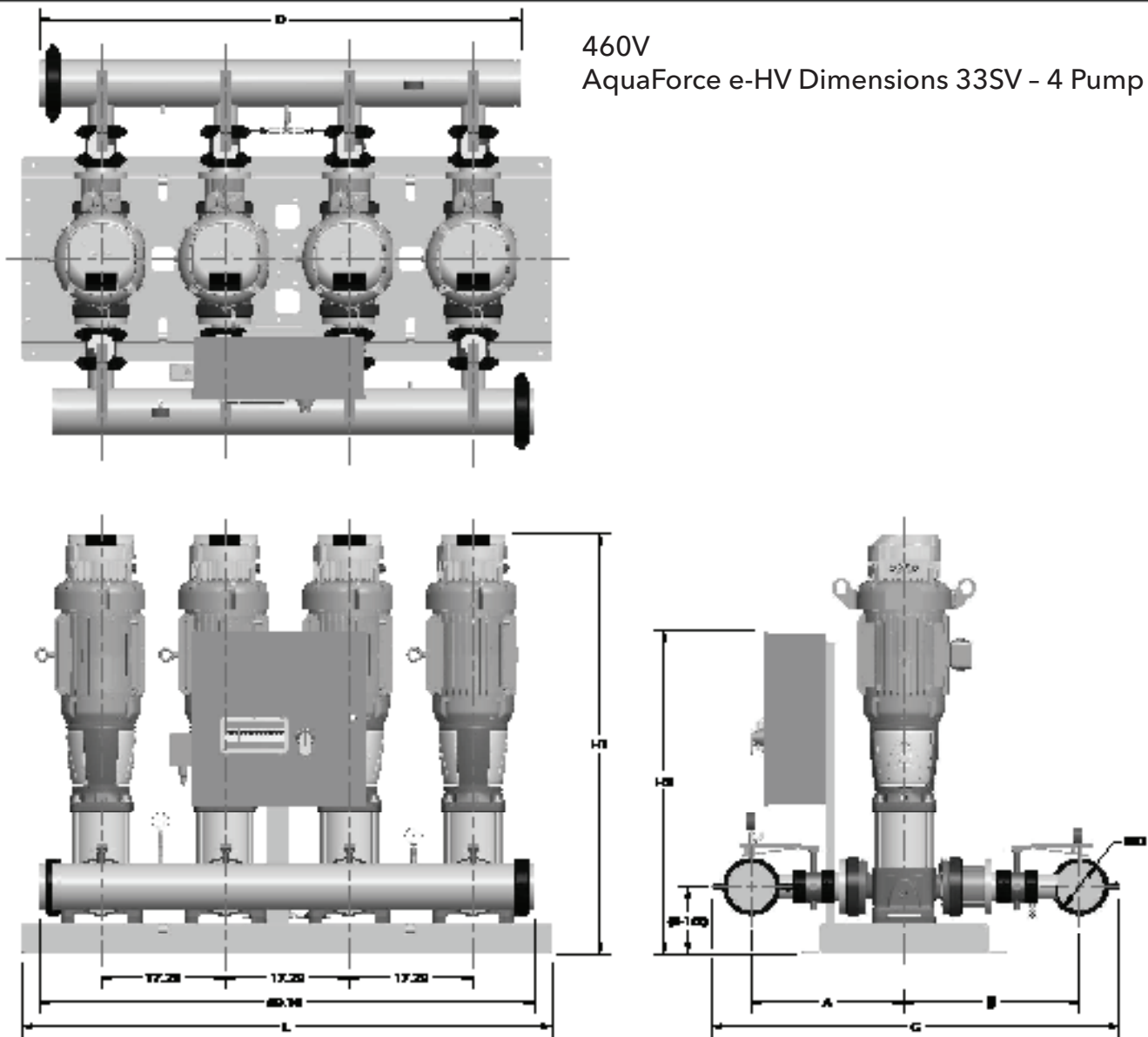

HVL406	MD	A	B	C	D	H	H1	H2	L	Wt.(lb)
336V11GG4C80	B	21.20	24.56	58.87	67.23	9.48	48.57	45.13	74.02	2082.3
336V10GH4F80	B	21.20	24.56	51.79	48.78	9.48	48.00	45.13	74.02	2155.9
336V22GH4F80	B	21.20	24.56	51.79	48.78	9.48	50.88	45.13	74.02	2201.9
336V21GJ4F80	B	21.20	24.56	51.79	48.78	9.48	52.00	45.13	74.02	2272.1
336V20GK4F80	B	21.20	24.56	51.79	48.78	9.48	55.80	45.13	74.02	2707.9
336V32GK4F80	B	21.20	24.56	51.79	48.78	9.48	58.80	50.63	74.02	2752.9
336V31GK4F80	B	21.20	24.56	51.79	48.78	9.48	58.80	50.63	74.02	2752.9

# Product Key

HV		3		D		3		10SV6GG4C60
Series		# of Pumps		Voltage		Header		Pump
HVL	eHV	2	Duplex	D	460/3/60	2	2 inch -105GPM	XXXXXXXXXX
		3	Triplex	L	208-230/3/60	3	3 inch -230GPM	
G		4				4		4 inch -400GPM
Brand		Quadplex				6		6 inch -900GPM
G	GWT							

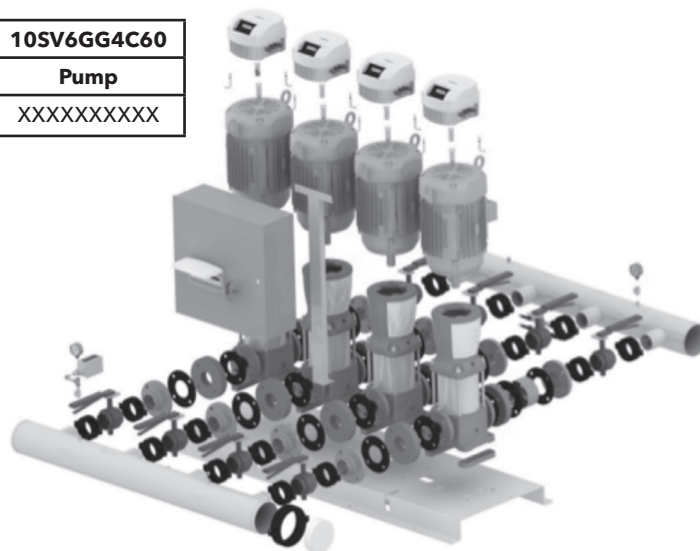

## Notice - Industrial Control Protocols

Certain Industrial Control Protocols do not offer security protections at protocol level and may be exposed to additional Cybersecurity risk. Customer security precautions including physical security measures are an important layer of defense in such cases. Xylem Goulds Water Technology AquaForce e-HV Variable Speed Boosters is designed with the consideration that it would be deployed and operated in a physically secure location.

- Xylem suggests that physical access to cabinets and/or enclosures containing AquaForce e-HV Variable Speed Boosters and the associated system should be restricted, monitored and logged at all times.
- Xylem recommends that customers inventory and document all industrial equipment running on their premises including model name, software version, and how devices are connected to each other and the local network.
- Xylem recommends creating and maintaining offline copies of configuration backups to all equipment involved in controlling critical processes.
- In cases where control commands for Xylem equipment are issued from SCADA or building management systems, Xylem recommends a regular check by operators to ensure the integrity of communications between these systems and Xylem equipment.
- Physical access to the communication lines should be restricted to prevent any attempts of wiretapping, sabotage. Best practice is to use metal conduits for the communication lines running between one cabinet to another cabinet.
- People with unauthorized physical access to the device could cause serious disruption of the device functionality. A combination of physical access controls to the location should be used, such as locks, card readers, and/or guards etc.
- Xylem Goulds Water Technology AquaForce e-HV Variable Speed Boosters supports the following physical access ports
  - RJ45 connector for removable keypad as well as Modbus RTU communications
  - RJ45 for Modbus TCP communications
  - Terminal block for Modbus RTU and other Digital IOs
- Xylem suggests access to above physical ports need to be restricted

## Xylem Product Cybersecurity

Xylem values your system security and the availability of your critical services. For more information on Xylem cybersecurity practices or to contact the cybersecurity team please visit [xylem.com/security](http://xylem.com/security).



Xylem Inc.  
 2881 East Bayard Street Ext., Suite A  
 Seneca Falls, NY 13148  
 Phone: (844) XYL-PUMP [844-995-7867]  
 Fax: (888) 322-5877  
[www.xylem.com/goulds](http://www.xylem.com/goulds)

Goulds is a registered trademark of Goulds Pumps, Inc. and is used under license.  
 © 2021 Xylem Inc. BAFEHV R8 April 2021