



1DW

SUBMERSIBLE DEWATERING PUMP

FEATURES

Impeller: AISI 304 SS open impeller

Diffuser Plate: AISI 304 SS with Polyurethane coating for maximum resistance to abrasion.

Casing: AISI 304 SS

Mechanical Seal: Silicon carbide sealing faces, all metal components of AISI type 300 stainless steel running in protected oil chamber.

Elastomers: BUNA-N

Shaft: AISI type 304 stainless steel high strength pump shaft with keyed and locking cap screw impeller fastening.

Motor: Air filled class F insulated design for continuous use.

Designed for Continuous Operation: Pump ratings are within the motor's working limits and can be operated continuously without damage.

Bearings: Upper and lower heavy duty ball bearing construction.

APPLICATIONS

Specifically designed for the following uses:

- Handling dirty waters
- Draining ditches and pits
- Excavating in the building trades
- Water transfer
- Industrial water drainage or transfer

SPECIFICATIONS

Pump:

- Discharge size: 1½" NPT
- Capacities: up to 110 GPM
- Total heads: up to 66 feet TDH
- Maximum solids: ¾" spherical
- Mechanical seal: Silicon carbide rotary/silicon carbide stationary, 300 series stainless steel metal parts, BUNA-N elastomers.
- Maximum submergence: 23'
- Temperature limit: 120°F (50°C) maximum
- Fasteners: 300 series stainless steel.

Motor:

- Single phase: 60 Hz, 3500 RPM, ½ HP, 115 and 230 V; ¾ and 1 HP, 230 V only.
- Three phase: 60 Hz, 3500 RPM, ½ to 1½ HP, 230 or 460 V.
- Built-in thermal overload protection with automatic reset on single phase models.
- Three phase: Overload protection must be provided in starter unit with three phase pumps.
- Power cord: ½ HP 30' cord; all other HP's 20' cord
- Class F insulation

AGENCY LISTINGS (Three phase only)



Tested to UL 778 and CSA 22.2 108 Standards
By Canadian Standards Association
File #LR38549

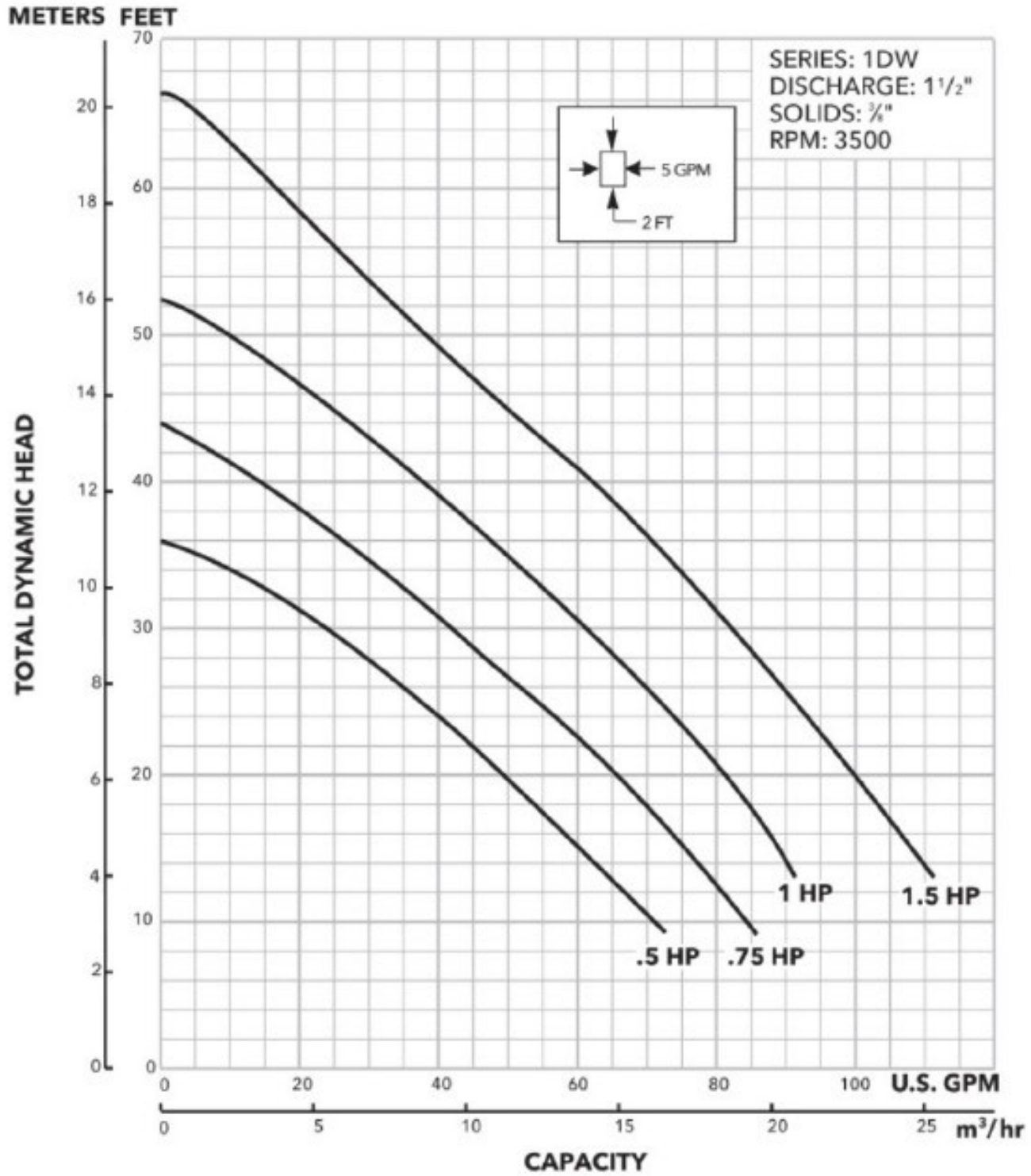

DIMENSIONS

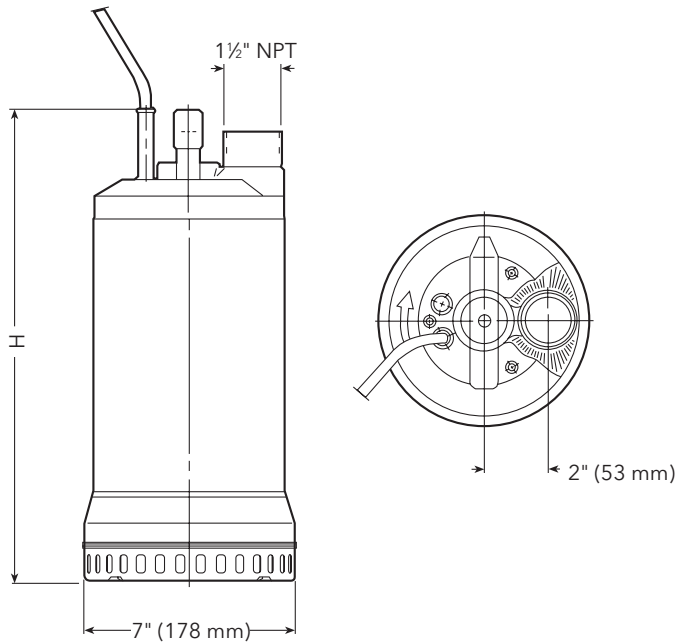

Series	HP	Phase	Dimensions in inches (mm)	Discharge Size
			H	
1DW	1/2	1	14 1/8 (363)	1 1/2"
		3	13 3/8 (348)	
	3/4	1	15 1/8 (383)	
		3	14 1/8 (363)	
	1	1	15 1/8 (403)	
		3	15 1/8 (383)	
1 1/2	3	15 1/8 (403)		

MECHANICAL DATA

Order Number	HP	Volts	Phase	Maximum Amps	RPM	Weight (Lbs.)
1DW51C0EA	1/2	115	1	10.3	3450	29
1DW51C1EA		230		4.5		
1DW51C3EA		3	460	2.5		27
1DW51C4EA				1.3		
1DW51D1EA	3/4	230	1	5.7		32
1DW51D3EA			3	3.6		
1DW51D4EA		460		1.8		
1DW51E1EA	1	230	1	6.3		38
1DW51E3EA			3	4.0		
1DW51E4EA		460		2.0	33	
1DW51F3EA	1 1/2	230	3	5.6	37	
1DW51F4EA		460		2.7		

Component	Material
Pump body and motor casing	Stainless steel (AISI 304)
Outer sleeve	Stainless steel (AISI 304)
Impeller	Stainless steel (AISI 304)
Motor Shaft	Stainless steel (AISI 304)
Suction strainer	Stainless steel (AISI 304)
Front diffuser plate	Stainless steel (AISI 304) coated with polyurethane elastomer
Lower mechanical seal	Silicon carbide/silicon carbide
Upper lip seal	Nitrile rubber
Handle	Stainless steel (AISI 304) coated with polyacetalic resin

AGENCY LISTINGS (Three phase only)



Tested to UL 778 and CSA 22.2 108 Standards
By Canadian Standards Association
File #LR38549



Xylem Inc.
2881 East Bayard Street Ext., Suite A
Seneca Falls, NY 13148
Phone: (866) 325-4210
Fax: (888) 322-5877
www.xylem.com/goulds

Xylem is a registered trademark of Xylem Inc. or one of its subsidiaries.
Goulds is a registered trademark of Goulds Pumps, Inc. and is used under license.
All other trademarks or registered trademarks are property of their respective owners.