

Models

Triplex Ceramic
Plunger Pump
Operating Instructions/
Repair and Service Manual

P460A/P480/P414

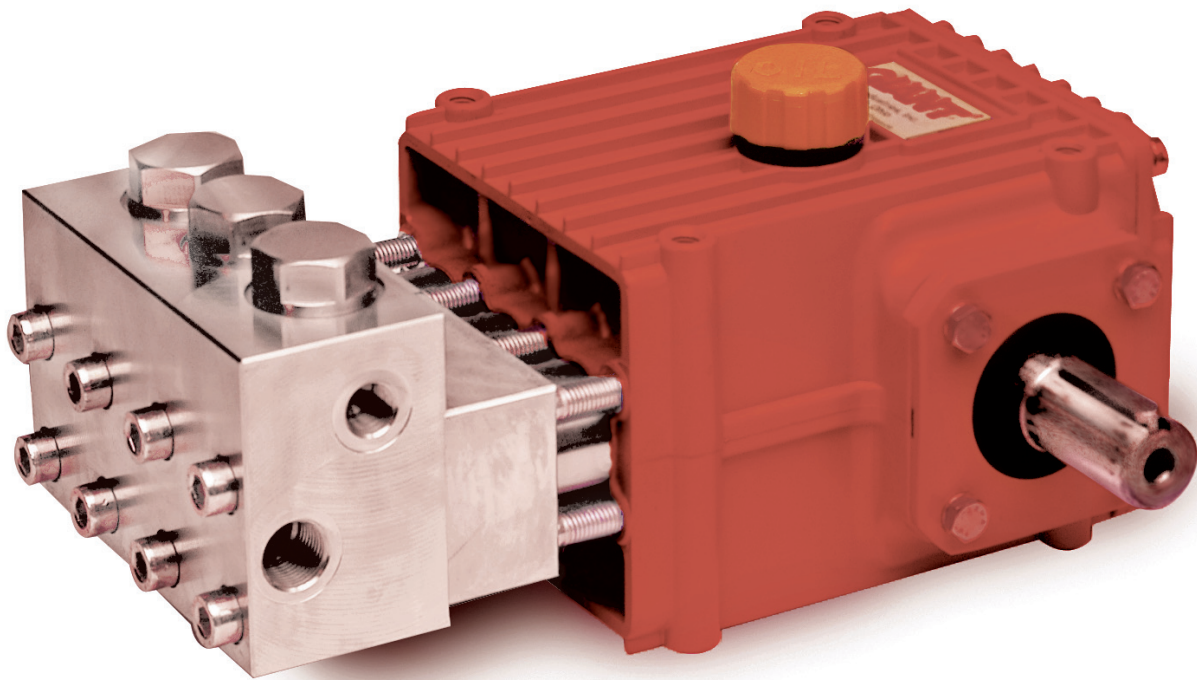

Updated 02/12

Contents:

Installation Instructions:	page 2
Pump Specifications:	page 3
Parts List/Torque Specs:	page 4
Exploded View/Kits:	page 5
Reassembly Instructions:	page 6
Dimensions:	page 7
Warranty Information	back page

Installation Instructions

Installation of the Giant Industries, Inc., pump is not a complicated procedure, but there are some basic steps common to all pumps. The following information is to be considered as a general outline for installation. If you have unique requirements, please contact Giant Industries, Inc. or your local distributor for assistance.

1. The pump should be installed flat on a base to a maximum of a 15 degree angle of inclination to ensure optimum lubrication.
2. The inlet to the pump should be sized for the flow rate of the pump with no unnecessary restrictions that can cause cavitation. Teflon tape should be used to seal all joints. If pumps are to be operated at temperatures in excess of 104° F (40°C,) it is important to insure a positive head to the pump to prevent cavitation.
3. The discharge plumbing from the pump should be properly sized to the flow rate to prevent line pressure loss to the work area. It is essential to provide a safety bypass valve between the pump and the work area to protect the pump from pressure spikes in the event of a blockage or the use of a shut-off gun.
4. Crankshaft rotation on Giant Industries, Inc. pumps should be made in the direction designated by the arrows on the pump crankcase. Reverse rotation may be safely achieved by following a few guidelines available upon request from Giant Industries, Inc. Required horsepower for system operation can be obtained from the charts on pages 3 through 5.
5. Before beginning operation of your pumping system, remember: Check that the crankcase and seal areas have been properly lubricated per recommended schedules. Do not run the pump dry for extended periods of time. Cavitation will result in severe damage. Always remember to check that all plumbing valves are open and that pumped media can flow freely to the inlet of the pump.

Finally, remember that high pressure operation in a pump system has many advantages. But, if it is used carelessly and without regard to its potential hazard, it can cause serious injury.

IMPORTANT OPERATING CONDITIONS

Failure to comply with any of these conditions invalidates the warranty.

1. Prior to initial operation, add oil to the crankcase so that oil level is between the two lines on the oil dipstick. DO NOT OVERFILL.
2. Pump operation must not exceed rated pressure, volume, or RPM. A pressure relief device must be installed in the discharge of the system.
3. Acids, alkalines, or abrasive fluids cannot be pumped unless approval in writing is obtained before operation from Giant Industries, Inc.
4. Run the pump dry approximately 10 seconds to drain the water before exposure to freezing temperatures.

Use SAE 80-90 Industrial Gear Lube Oil (Giant's P/N 01154)

Crankcase oil should be changed after the first 50 hours of operation, then at regular intervals of 200 hours or less depending on operating conditions.

NOTE: Contact Giant Industries for Service School Information. Phone: (419)-531-4600

Pump Specifications

U.S. Measurements

	Max. Flow	Max. Discharge Pressure	Max. Speed	Power Req'd.	Plunger Diameter	Stroke	Gallons per Rev.
Model	GPM	PSI	RPM	BHP	in	in	gal/rev
P414	3.1	10,150	1450	21.7	0.55	0.94	0.00214
P460	3.2	7250	1450	16	0.55	0.94	0.00221
P480	3.8	7250	1450	19	0.55	0.94	0.00262

Metric Measurements

	Max. Flow	Max Discharge Pressure	Max. Speed	Power Req'd.	Plunger Diameter	Stroke	Liters per Rev.
Model	L/min	Bar	RPM	kW	mm	mm	L/rev
P414	11.8	700	1450	16.2	14	24	0.0081
P460	12.3	500	1450	11.9	14	24	0.00837
P480	14.5	500	1450	14.2	14	24	0.00992

Consult the factory for special requirements that must be met if the pump is to operate beyond one or more of the limits specified above.

Horsepower Ratings:

We recommend a 1.15 service factor be specified when selecting an electric motor as the power source.

To compute electric motor horsepower required, use the following formula: $HP = (GPM \times PSI) / 1450$.

The formula to determine the horsepower required for a gas engine is: $HP = (GPM \times PSI) / 1150$.

The formula to determine the horsepower required for a diesel engine is: $HP = (GPM \times PSI) / 1250$.

For the Application of a Hydraulic Motor:

To Determine the Torque of a Hydraulic Motor -- $(GPM \times PSI \times 36.77) / RPM = \text{Torque (in-lbs)}$

Calculating RPM / GPM of Pump:

A pump must be connected to an electric motor or gas or diesel engine with the correct ratio of pulleys and belts to attain the required speed and GPM. The use of a Variable Frequency Drive (VFD) may also be used to control the RPM of a properly sized electric motor when variable flows are required.

$$(\text{Max. Pump RPM} / \text{Rated Pump GPM}) \times \text{Required Pump GPM} = \text{Required Pump RPM}$$

To calculate a pulley diameter one (1) pulley diameter and the required pump RPM must be known:

$$(\text{Pump RPM} \times \text{Pump Pulley Diameter}) / \text{Motor RPM} = \text{Motor Pulley Diameter}$$

$$(\text{Motor RPM} \times \text{Motor Pulley Diameter}) / \text{Pump RPM} = \text{Pump Pulley Diameter}$$

Common Specifications:

	<u>US</u>	<u>Metric</u>
Inlet Pressure	-4.35 to 145 PSI....	-0.3 to 10 Bar
Max. Temp.	104 °F	40°C
Inlet Ports	(2) 1/2" BSP	
Discharge Ports	(2) 3/8" BSP	
Shaft Rotation.....	Top of pulley towards fluid end	
Crankshaft Diameter.....	28mm	
Key Width	8mm	
Shaft Mounting	Either side ¹	
Weight	46 lbs.	21 kg
Crankcase Capacity	30 fl.oz.	0.9 Liters

¹NOTES:

In order to drive the pump from the side opposite the present shaft extension, simply remove the valve casing from the crankcase and rotate the pumps 180 degrees to the desired position. Be certain to rotate the seal case (item #20) as well, so that the weep holes are down at the six o'clock position. Exchange the oil fill and the oil drain plugs, also. Refer to the repair instructions as necessary for the proper assembly sequence.

P460A/P480/P414 PARTS LIST

<u>ITEM</u>	<u>PART</u>	<u>DESCRIPTION</u>	<u>QTY.</u>	<u>ITEM</u>	<u>PART</u>	<u>DESCRIPTION</u>	<u>QTY.</u>
1	08377	Crankcase	1	19	05444	Oil Seal	3
2	08378	Oil Fill Plug with Gasket	1	20	05938	Seal Adapter	3
3	06479	Crankcase Cover	1	20A	06482	Seal Case	1
3A	07186	Oil Sight Glass w/Gasket	1	21	07266	O-Ring	3
4	08380	O-Ring	1	23	06483	Grooved Seal Packing	6
5	07109	Oil Drain Plug	1	23A	13036	Spacer Ring	3
5A	07182	Gasket for Oil Drain Plug	1	24	06484	Pressure Ring	3
5B	08092	Plug with Gasket	1	25	06485	Weep Return Ring	3
6	01010	Screw	4	25A	06486	Support Ring	6
6A	01011-0400	Spring Washer	4	25B	06487	O-Ring	6
7	05290	Bearing Cover Open	1	26	06488	Valve Casing (P460/P480)	1
8	05291	Bearing Cover Closed	1	26	05939	Valve Casing (P414)	1
8A	05292	Shim	1	27A	05543	Valve Assy.	6
8B	05293	Shim	1			(Includes items 27-31)	
9	01016	O-Ring	2	27	05541	Valve Seat	6
10	07114	Screw with Washer	8	28	05542	Valve Plate	6
11	07459	Radial Shaft Seal	1	29	07906	Valve Spring	6
12	05350	Bearing	2	30	07907	Valve Spring Retainer	6
13	08475	Crankshaft, P460	1	31	07770	O-Ring	6
13	08482	Crankshaft, P480	1	32	08406-0100	Plug	3
14	08091	Fitting Key	1	33	07489	O-Ring	3
15	08390	Connecting Rod Assy.	3	34	06494	Cap Screw	8
15A	07311	Screw with Washer	6	36	12256	Plug, 3/8" BSP	1
16	06480	Plunger Assy.	3	37	08486	Copper Washer	1
17	06790	Crosshead Pin	3	38	07109-0400	Plug, 1/2" BSP	1
				39	06272	Copper Washer	1

P460A/P480/P414 TORQUE SPECIFICATIONS

<u>Item</u>	<u>Part #</u>	<u>Description</u>	<u>Torque Amount</u>
15A	07311	Screw with Washer	216 in.-lbs.
32	08406-0100	Plug	110 ft.-lbs.
34	06494	Cap Screw	36 ft.-lbs.

Exploded View - P460A/P480

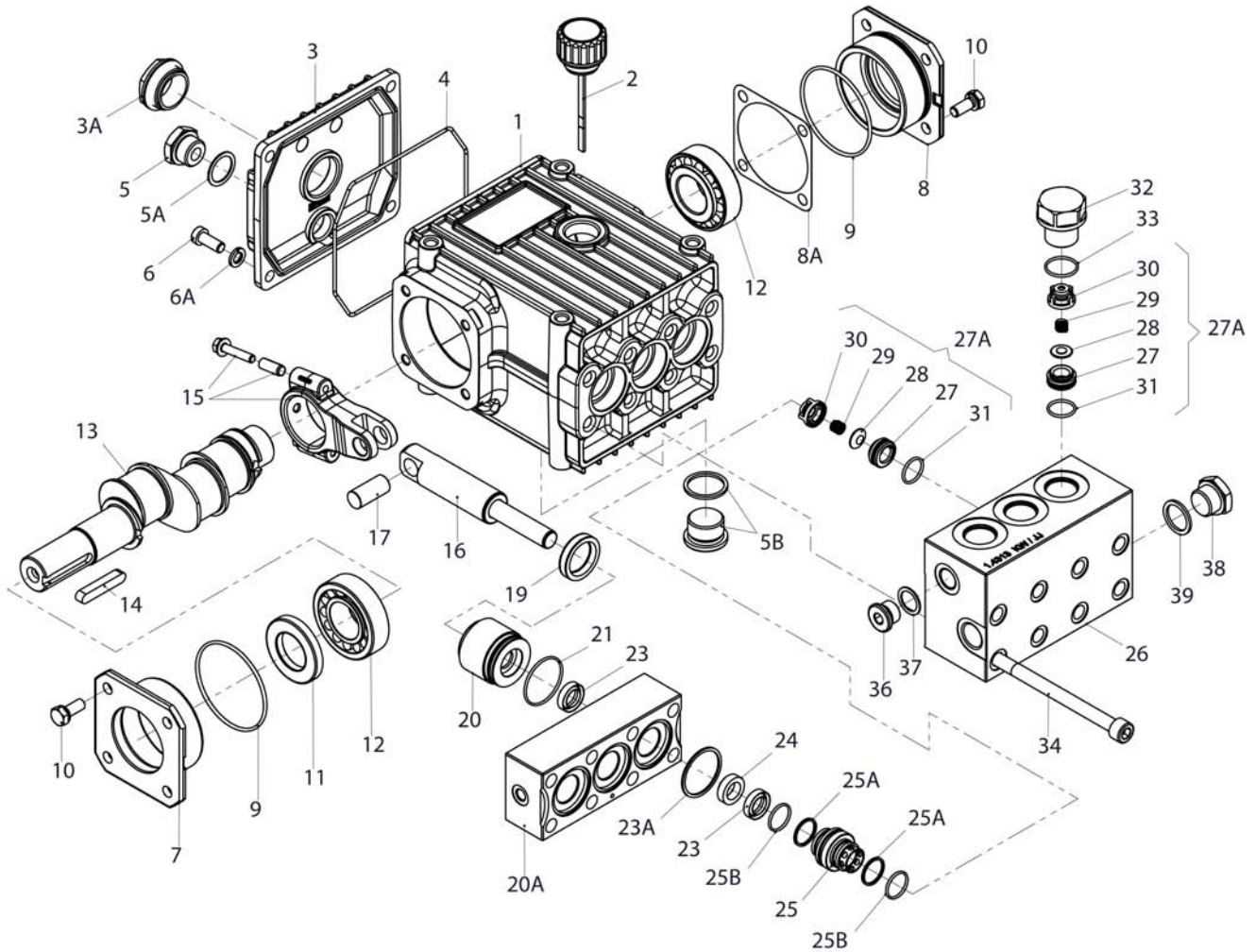

P460A/P480/P414 REPAIR KITS

Plunger Packing Kits

Part # 09499

Item	Part #	Description	Qty.
21	07266	O-Ring	3
23	06483	Grooved Seal Packing	6
23A	13036	Spacer Ring	3
24	06484	Pressure Ring	3

Oil Seal Kit

Part # 09306

Item	Part #	Description	Qty.
19	08366	Oil Seal	3

Valve Assembly Kits

Part # 09498

Item	Part #	Description	Qty.
27A	05543	Valve Assembly, Complete	6
33	07489	O-Ring	3

Reassembly Instructions - P460A/P480/P414 PUMPS

Inlet Valves

Remove inner hexagon screws (34) and pull off valve casing (26) to the front. Take out seal case (25) from valve casing (26). Remove the exposed inlet valve with a pair of flat nose pliers and the valve seat (27) with a valve puller. Disassemble parts and examine valve plate (28), valve seat (27), O-ring (31) and support ring (31A). Replace worn parts. Tighten inner hexagon screws (34) again to 30 ft-lbs. (40Nm).

Discharge Valves: With a socket 32mm wrench, screw out valve plugs (32). Remove the exposed discharge valves with a pair of flat nose pliers and the valve seat (27) with a valve seat puller. Disassemble parts and examine valve plate (28), valve seat (27), and O-rings (31, 33). Replace worn parts. Take care to reassemble in correct sequence. Tighten plugs (32) to 110 ft-lbs. (150Nm).

Seals

Screw out oil drain plug (5) and drain oil. Remove inner hexagon screws (34) and pull off valve casing (26) front-wise over the plungers (16).

Important! if the seal casing (20A) does not separate from the valve casing (26), press both casings apart by placing two flat screwdrivers in the side notches on the seal casing (20A). Be careful not to damage casing surfaces.

Remove seal cases (25) situated either in valve casing (26) or seal casing (20A). Separate seal casing (20A) from seal retainers (20). Remove grooved ring (23) and guide ring (24) from the seal casing (20A). Examine O-rings (25B) and support rings (25A) attached to seal casing (26). Check seal ring (23A) situated between valve casing and seal casing, and replace if necessary. Then remove seal retainers (20) from crankcase (1). Pull grooved ring (23) out of seal retainer (20). Check O-ring (21). Grease new seals and O-rings before reinstallation.

Important! Seal casing (20A) has a notched pin to ensure correct fitting. Reassemble parts in the proper sequence.

Important! The grooved seal (23) on the high-pressure side is to be fitted carefully into the seal casing (20A) using a 22mm plastic rod. Under no circumstances must the surface in the seal casing or the seal lip of the grooved seal be damaged.

Check surfaces of plunger (16). Damaged surfaces cause hard wear on seals. Deposits of all kinds must be removed from the plungers.

Important! The plunger surfaces are not to be damaged. If there are lime deposits in the pump, care must be taken that the drip-return bore in parts (25) and (26) ensure trouble-free drip-return.

If the plunger (16) is worn, the complete plunger must be changed. The ceramic pipe alone cannot be changed due to reasons of precision. When reassembling tighten inner hexagon screw (34) to 30 ft-lbs. (40 Nm).

If the plunger (16) is worn, the complete plunger must be changed. The ceramic pipe alone cannot be changed due to reasons of precision. When reassembling tighten inner hexagon screw (34) to 30 ft-lbs (40Nm).

Gear and Plunger

If oil leaks where the plunger (16) protrudes out of the gear, gear seals (19) and plungers have to be examined and replaced as necessary.

Gear Seal

Remove plug (5) and drain oil. Remove valve casing as described above. Take seal adapter (20) off plunger (16) and replace gear seal (19).

Plungers

Drain oil and remove crankcase cover (3). Take off screws on con rods (15). Be careful not to mix up the con rod halves. Push con rod shaft as far as possible into the crosshead guide. Loosen screws (10) and remove bearing covers (7&8) with the help of a screw-driver.

Take crankshaft out carefully so as not to bend the con rods. Remove and dismantle con rods and plungers (18). Replace worn parts.

To reinstall, insert con rods and plungers, put crankshaft in carefully and then push the bearing covers (7&8) onto the ends of the crankshaft. Screw on bearing covers with screws (10). Mount con rod halves and tighten screws (15) to 8 in-lbs. (11Nm). Mount crankcase cover (3) together with O-ring (4).

To rotate crankshaft to the opposite side.

The shaft end is on the left side of the pump looking at it from behind. If it should be on the other side, the valve casing (26) and seal casing (20A) have to be removed, turned by 180° and then put on again. Turn seal adapters (20) 180°, so that the leakage holes are underneath. Oil dipstick (2) and oil drain plug (58) have to be interchanged and crankcase cover turned by 180°.

Contact Giant Industries for service school information. Phone: (419) 531-4600

Model P460A/P480 Dimensions in(mm)

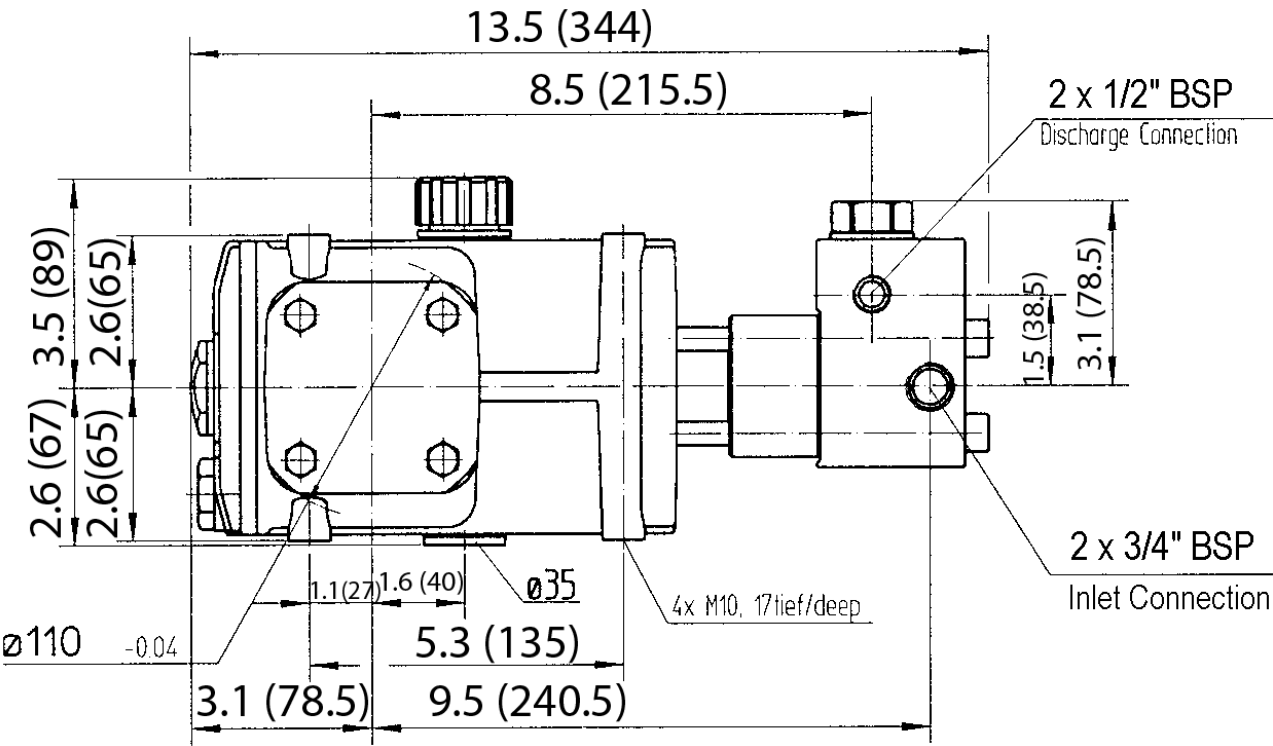
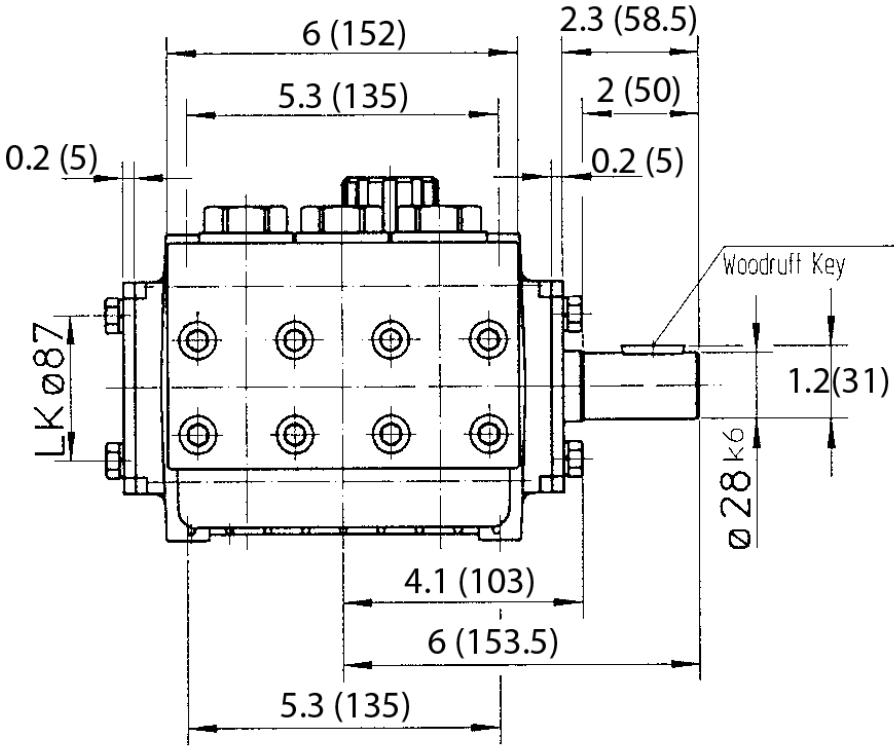

GIANT INDUSTRIES LIMITED WARRANTY

Giant Industries, Inc. pumps and accessories are warranted by the manufacturer to be free from defects in workmanship and material as follows:

1. For portable pressure washers and self-service car wash applications, the discharge manifolds are guaranteed for the life of the pump. Our other pump parts, used in portable pressure washers and in car wash applications, are warranted for five years from the date of shipment for all pumps used in NON-SALINE, clean water applications.
2. One (1) year from the date of shipment for all other Giant industrial and consumer pumps.
3. Six (6) months from the date of shipment for all rebuilt pumps.
4. Ninety (90) days from the date of shipment for all Giant accessories.

This warranty is limited to repair or replacement of pumps and accessories of which the manufacturer's evaluation shows were defective at the time of shipment by the manufacturer. The following items are NOT covered or will void the warranty:

1. Defects caused by negligence or fault of the buyer or third party.
2. Normal wear and tear to standard wear parts.
3. Use of repair parts other than those manufactured or authorized by Giant.
4. Improper use of the product as a component part.
5. Changes or modifications made by the customer or third party.
6. The operation of pumps and or accessories exceeding the specifications set forth in the Operations Manuals provided by Giant Industries, Inc.

Liability under this warranty is on all non-wear parts and limited to the replacement or repair of those products returned freight prepaid to Giant Industries which are deemed to be defective due to workmanship or failure of material. A Returned Goods Authorization (R.G.A.) number and completed warranty evaluation form is required prior to the return to Giant Industries of all products under warranty consideration. Call (419)-531-4600 or fax (419)-531-6836 to obtain an R.G.A. number.

Repair or replacement of defective products as provided is the sole and exclusive remedy provided hereunder and the MANUFACTURER SHALL NOT BE LIABLE FOR FURTHER LOSS, DAMAGES, OR EXPENSES, INCLUDING INCIDENTAL AND CONSEQUENTIAL DAMAGES DIRECTLY OR INDIRECTLY ARISING FROM THE SALE OR USE OF THIS PRODUCT.

THE LIMITED WARRANTY SET FORTH HEREIN IS IN LIEU OF ALL OTHER WARRANTIES OR REPRESENTATION, EXPRESS OR IMPLIED, INCLUDING WITHOUT LIMITATION ANY WARRANTIES OR MERCHANTABILITY OR FITNESS FOR A PARTICULAR PURPOSE AND ALL SUCH WARRANTIES ARE HEREBY DISCLAIMED AND EXCLUDED BY THE MANUFACTURER.

