

# Pump Model P450-5100

Corrosion Resistant Pump

Triplex Ceramic  
Plunger Pump  
Operating Instructions  
Repair and Service Manual

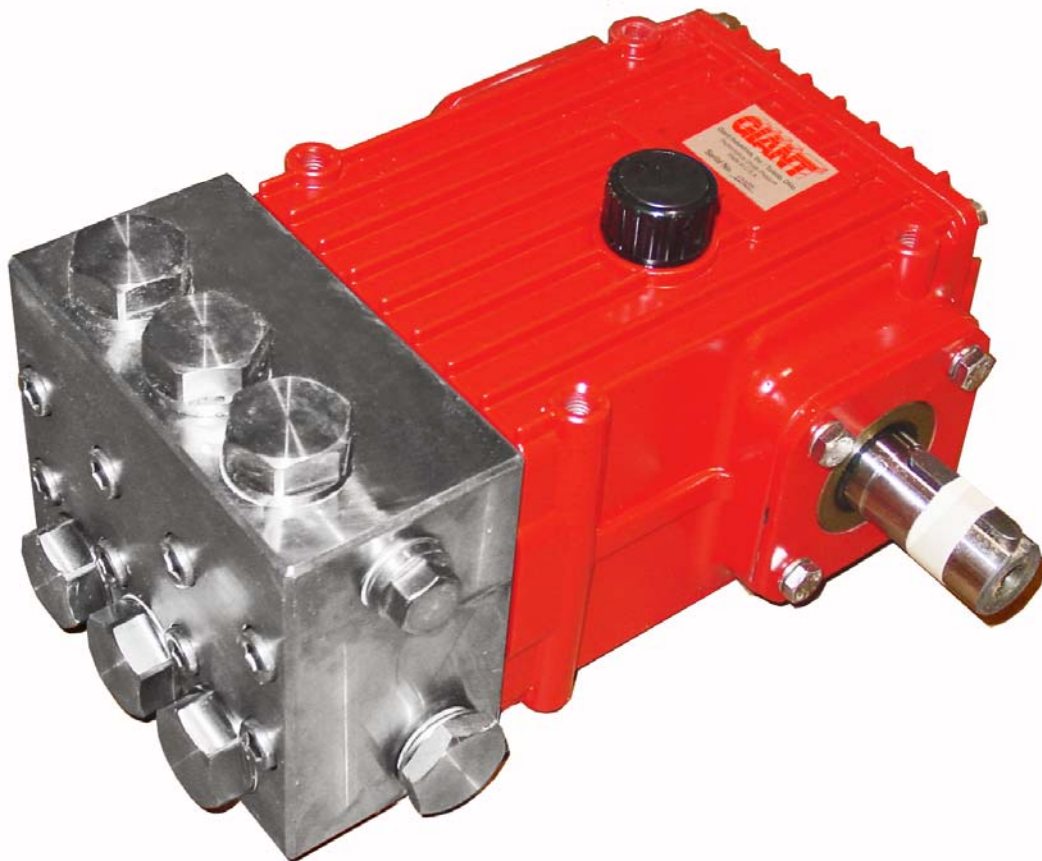

## Contents:

Installation Instructions:	page 2
Specifications:	page 3
Exploded View	page 4
Parts List / Kits	page 5
Repair Instructions:	pages 6-8
Pump mounting selection Guide:	page 9
Recommended Spare Parts List	page 9
Torque Specs:	page 9
Trouble Shooting:	page 10
Dimensions:	page 11
Warranty Information	back page

## INSTALLATION INSTRUCTIONS

Installation of the Giant Industries, Inc., pump is not a complicated procedure, but there are some basic steps common to all pumps. The following information is to be considered as a general outline for installation. If you have unique requirements, please contact Giant Industries, Inc. or your local distributor for assistance.

1. The pump should be installed flat on a base to a maximum of a 15 degree angle of inclination to ensure optimum lubrication.
2. The inlet to the pump should be sized for the flow rate of the pump with no unnecessary restrictions that can cause cavitation. Teflon tape should be used to seal all joints. If pumps are to be operated at temperatures in excess of 160° F, it is important to insure a positive head to the pump to prevent cavitation.
3. The discharge plumbing from the pump should be properly sized to the flow rate to prevent line pressure loss to the work area. It is essential to provide a safety bypass valve between the pump and the work area to protect the pump from pressure spikes in the event of a blockage or the use of a shut-off gun.
4. Use of a dampener is necessary to minimize pulsation at drive elements, plumbing, connections, and other system areas. The use of a dampener with Giant Industries, Inc. pumps is optional, although recommended by Giant Industries, Inc. to further reduce system pulsation. Dampeners can also reduce the severity of pressure spikes that occur in systems using a shut-off gun. A dampener must be positioned downstream from the unloader.
5. Crankshaft rotation on Giant Industries, Inc. pumps should be made in the direction designated by the arrows on the pump crankcase. Reverse rotation may be safely achieved by following a few guidelines available upon request from Giant Industries, Inc. Required horsepower for system operation can be obtained from the chart on page 3.
6. Before beginning operation of your pumping system, remember: Check that the crankcase and seal areas have been properly lubricated per recommended schedules. Do not run the pump dry for extended periods of time. Cavitation will result in severe damage. Always remember to check that all plumbing valves are open and that pumped media can flow freely to the inlet of the pump.

Finally, remember that high pressure operation in a pump system has many advantages. But, if it is used carelessly and without regard to its potential hazard, it can cause serious injury.

### IMPORTANT OPERATING CONDITIONS

Failure to comply with any of these conditions invalidates the warranty.

1. Prior to initial operation, add oil to the crankcase so that oil level is between the two lines on the oil dipstick. **DO NOT OVERFILL.**

**Use Giant Oil # 01154 or the equivalent  
SAE 80W - 90 Industrial Gear oil**

Crankcase oil should be changed after the first 50 hours of operation, then at regular intervals of 500 hours or less depending on operating conditions.

2. Pump operation must not exceed rated pressure, volume, or RPM. A pressure relief device must be installed in the discharge of the system.
3. Acids, alkalines, or abrasive fluids cannot be pumped unless approval in writing is obtained before operation from Giant Industries, Inc.
4. Run the pump dry approximately 10 seconds to drain the water before exposure to freezing temperatures.

**NOTE: Contact Giant Industries for Service School Information. Phone: (419)-531-4600**

# Specifications

## Model P450-5100

	U.S.	(Metric)
Volume .....	5.5 GPM .....	(20.8 l/m)
Discharge Pressure .....	5075 PSI .....	(350 bar)
Inlet Pressure .....	90 PSI .....	(6.2 bar)
Stroke.....	0.79" .....	20mm
RPM .....		Up to 1450 RPM
Plunger Diameter.....	0.71" .....	18mm
Temperature of Pumped Fluids .....	160 °F .....	(70°C)
Inlet Ports .....		(2) 3/4" BSP
Discharge Ports.....		(2) 1/2" BSP
Shaft Rotation .....		Top of pulley towards fluid end
Crankshaft Diameter .....		28mm
Key Width .....		8mm
Shaft Mounting .....		Either side <sup>1</sup>
Weight.....	36.5 lbs.....	(16.6 kg)
Crankcase Capacity .....	30fl.oz.....	(0.89 liters)

Consult the factory for special requirements that must be met if the pump is to operate beyond one or more of the limits specified above.

**NOTES:**

In order to drive the pump from the side opposite the present shaft extension, simply remove the valve casing from the crankcase and rotate the pumps 180 degrees to the desired position. Be certain to rotate the seal case (item #20) as well, so that the weep holes are down at the six o'clock position. Exchange the oil fill and the oil drain plugs, also. Refer to the repair instructions as necessary for the proper assembly sequence.

<b>P450-5100</b>					
<b>HORSEPOWER REQUIREMENTS</b>					
<b>RPM</b>	<b>GPM</b>	<b>2000 PSI</b>	<b>3000 PSI</b>	<b>4000 PSI</b>	<b>5000 PSI</b>
800	3.0	4.1	6.2	8.3	10.3
933	3.5	4.8	7.2	9.7	12.1
1066	4.0	5.5	8.3	11.0	13.8
1200	4.5	6.2	9.3	12.4	15.5
1450	5.5	7.6	11.4	15.2	19.0

**HORSEPOWER RATINGS:**

The rating shown are the power requirements for the pump. Gas engine power outputs must be approximately twice the pump power requirements shown above.

We recommend a 1.15 service factor be specified when selecting an electric motor as the power source. To compute specific pump horsepower requirements, use the following formula:

$$HP = (GPM \times PSI) / 1450$$

**SPECIAL NOTE:**

The theoretical gallons per revolution (gal/rev) is 0.00379.  
To find specific outputs at various RPM, use the formula:  $GPM = 0.00379 \times RPM$

# P450-5100 Exploded View

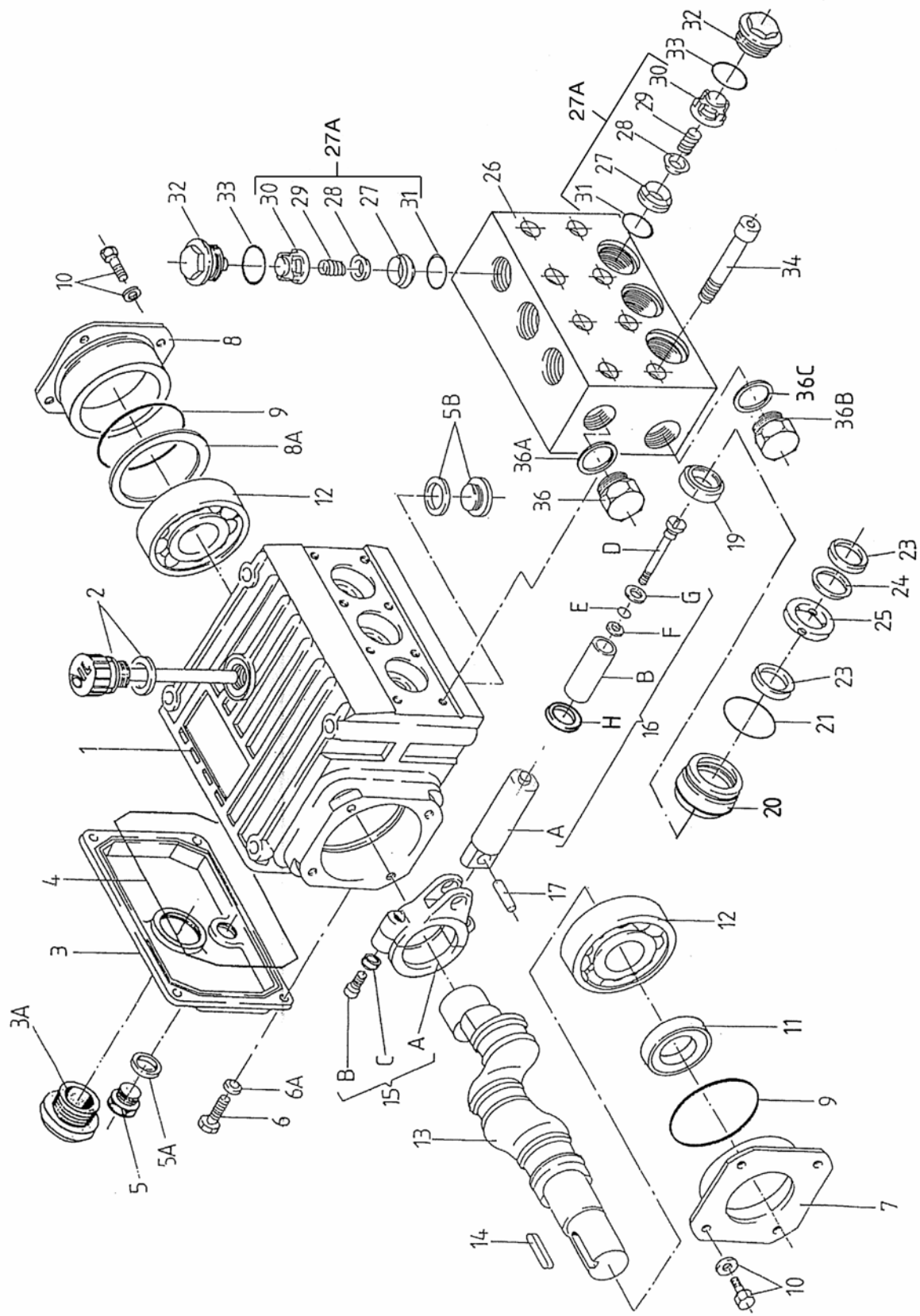

## P450-5100 PUMP PARTS LIST

ITEM	PART	DESCRIPTION	QTY.	ITEM	PART	DESCRIPTION	QTY.
1	08377	Crankcase	1	16D	08399-0100	Tensioning Screw	3
2	08378	Oil Fill Plug with Gasket	1	16E	07023-0001	O-Ring	3
3	06479	Crankcase cover	1	16F	07203	Backup Ring	3
3A	07186	Oil Sight Glass w/ Gasket	1	16G	07161-0100	Copper Washer	3
4	08380	O-Ring	1	16H	06931	Oil Scraper	3
5	07109-0400	Oil Drain Plug	1	17	06790	Crosshead Pin	3
5A	07182	Gasket for Oil Drain Plug	1	19	05444	Oil Seal	3
5B	08092-0100	Plug with Gasket	1	20	05534-0100	Seal Case	3
6	01010-0100	Screw	4	21	07266	O-Ring	3
6A	01011-0400	Spring Washer	12	23	08477	V-Sleeve, 18mm	6
7	05290	Bearing Cover, Open	1	24	07929	Pressure Ring	3
8	05291	Bearing Cover, Closed	1	25	06804	Weep Return Ring	3
8A	05292	Shim	1	26	08470-5000	Manifold	1
8B	05293	Shim (May not be present)	1	27A	05578	Valve Assembly	6
9	01016	O-Ring	2	27	05576	Valve Seat	6
10	07114-0100	Screw with Washer	8	28	05577	Valve Plate	6
11	07459	Radial Shaft Seal	1	29	07906-0100	Valve Spring	6
12	05350	Bearing	2	30	07907	Valve Spring Retainer	6
13	08482	Crankshaft	1	31	07770-0001	O-Ring	6
14	08091	Fitting Key	1	32	08406-0100	Plug	6
15	08390	Connecting Rod Assembly	3	33	07489	O-Ring	6
15B	05349	Screw	3	34	08396-0100	Cap Screw	8
15C	05348	Washer	3	36	12250	Plug, 1/2" BSP	1
16	05575	Plunger Assy. Items 16A-16G	3	36A	06807	Steel Ring	1
16A	08384-0600	Plunger Base	3	36B	13150-0100	Plug, 3/4", S.S.	1
16B	08397	Plunger Pipe	3	36C	06808	Steel Seal Ring	1

## Repair Kits

### Plunger Packing Kits

#09141

Item	Part #	Description	Qty.
21	07266	O-Ring	3
23	08477	V-Sleeve, 18mm	6
24	07929	Pressure Ring	3

### Oil Seal Kit

#09641

Item	Part #	Description	Qty.
19	05444	Oil Seal	3

### Valve Assembly Kit

#09646

Item	Part #	Description	Qty.
27A	05578	Valve Ass'y, Complete	6
33	07489	O-Ring	6

## REPAIR INSTRUCTIONS - P450-5100

*Note: Always take time to lubricate all metal and nonmetal parts with a light film of oil before reassembly. This step will ensure proper fit, at the same time protecting the pump nonmetal parts (i.e., the elastomers) from cutting and scoring.*

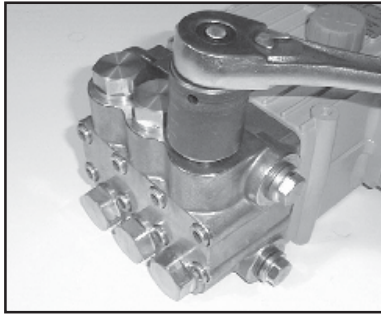

- 1) With a socket wrench, remove the three discharge valve plugs and three inlet valve plugs (32). Inspect the o-ring (33) for wear and replace if damaged.

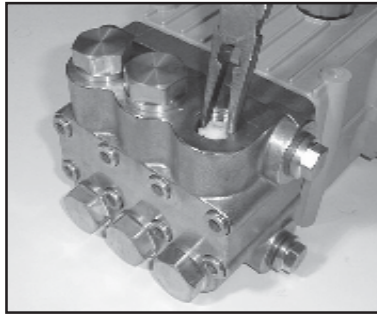

- 2) Using needle nose pliers, remove the inlet and discharge valve assemblies (27A). Note: It may become necessary to remove the valve seat (27) from the valve casing using a slidehammer.

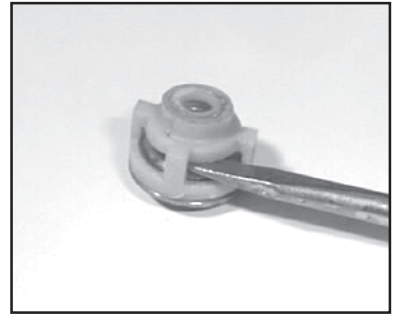

- 3) By inserting a small screw driver between the valve seat (27) and the valve spring retainer (30), the valve assembly can be separated.

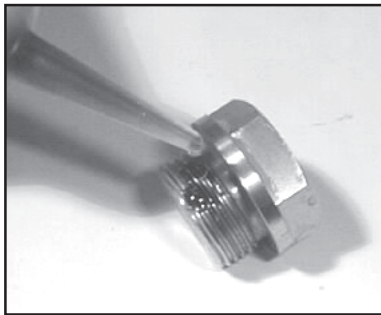

- 4) Remove the o-ring (31). Inspect all parts for wear and replace as necessary. Apply one drop of loctite 243 to the valve plugs (32) and tighten to 125 lb-ft (170 Nm)

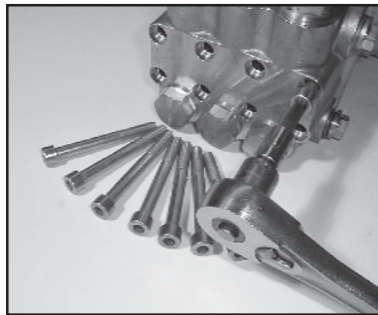

- 5) Use a 8mm allen wrench to remove the 8 socket head cap screws (34). Carefully slide the valve casing (26) out over the plungers.

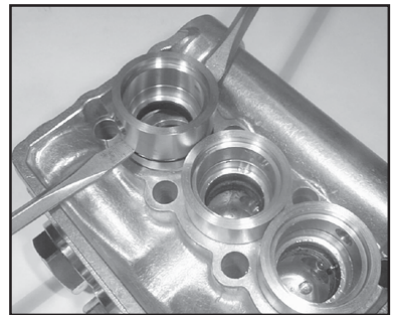

- 6) Remove seal adaptors (20) and weep return rings (25) from the valve casing.

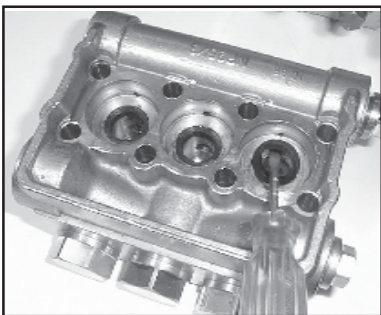

- 7) Remove the pressure rings (24) and v-sleeves (23) from the valve casing (26).



- 8) Remove the weep grooved seal (23) out of the seal adaptor (20). Check O-rings (21).

**IMPORTANT!** The grooved seal (23) on the high-pressure side is to be fitted carefully into the valve casing (26) using a screwdriver. Under no circumstances must the seal surface in the valve casing or the seal lip be damaged.

## REASSEMBLY INSTRUCTIONS - P450-5100

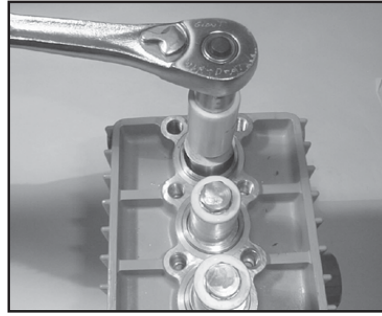
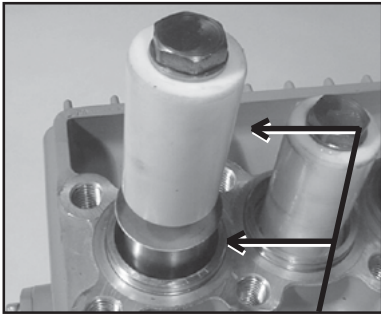

**IMPORTANT!** Care must be taken that glue does not get between the plunger pipe (16B) and plunger base (16A). The plunger pipe should not be strained by eccentric tightening of the tension screw or through damage to front surface of plunger, otherwise it is liable to fracture.

- 9) Check surfaces of plunger (16). Damaged surfaces cause accelerated seal wear. Deposits of all kinds must be removed from the plungers.

**IMPORTANT!** Plunger surfaces are not to be damaged. If there are lime deposits in the pump, care must be taken that the drip-return bore in parts (25) and (26) ensure trouble-free drip-return.

- 10) If the plunger pipe (16B), or oil seal (19) is worn, remove tension screw (16D) and remove along with plunger pipe (16B). Check and clean plunger surface (16A), check oil scraper (16H). Remove the seal case (20) and, if necessary, replace oil seals with seal lips facing crankcase (1). Cover thread of tension screw (16D) with a thin film of Loctite and tighten carefully to 221-265 in-lbs (25-30NM).

- 11) After installation of high pressure seals (23), place seal adapter (20) with weep seals & pressure ring installed, weep return ring (25) and high pressure weep return ring (24) over plungers. Slide valve casing over plungers and seat firmly. Replace the 8 socket head cap screws (34) and tighten to 29.5 lb-ft (40 Nm) in a crossing pattern (as shown on the right).

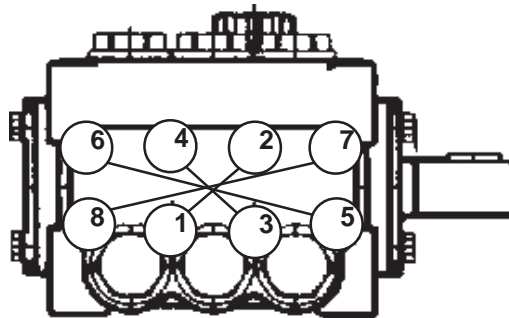

*Contact Giant Industries for service school information. Phone: (419) 531-4600*

## Gear End

If oil leaks where the plunger (16) extends from the crankcase (1), the oil seals (19) and plungers (16) must be examined and replaced if necessary. Remove oil plug (5) and drain oil; remove crankcase cover (3). Remove valve casing (26), and seal case (20). Then remove plunger pipes (16B) and oil scrapers (16H) as described above.

**IMPORTANT** Before removing conn-rods be aware of their position on the crankshaft so as to return them to the same location when re-assembling.

Remove screws from connecting rods (15), separate the back conn-rod half from the crankshaft and the front conn-rod half. The conn-rod halves must be kept as pairs - do not mix them up. Push conn-rod shaft as far as possible into the crosshead guide. Remove screws (10) and pry bearing covers (7,8) off gently with a screwdriver.

Carefully remove crankshaft (13) by threading it through the conn-rods (15), making sure not to bend the conn-rods. Remove and disassemble conn-rods and plungers (16) paying close attention not to damage the plungers. Pry out oil seal (19) using a screwdriver. Examine plunger surfaces (16A) and replace if necessary.

To re-assemble, first press the oil seal (19) into the crankcase. Then insert conn-rods with plungers remembering their original location. Thread in the crankshaft (13). Replace bearing cover (7) and o-ring (9) together with the radial shaft seal (11) and roller bearing (12) and fix in place with screws (10). Replace roller bearing (12), bearing cover (8) and o-ring (9). Adjust the clearance by fitting shims (8A) under the bearing cover as required to ensure that the crankshaft (13) turns easily without play being felt. Finally, mount conn-rod halves on crankshaft matching them with other half and tighten screws (15) to 97 lb-in (11 Nm). Replace crankcase cover (3) and o-ring (4). When remounting the valve casing (26), tighten hexagon socket screws (34) to 29.5 lb-ft (40 Nm).

## To Move Crankshaft to Opposite Side

Remove the valve casing (26) and seal case (20). Then rotate the crankcase 180°. Interchange the oil plug ((5B) with oil dipstick (2). Rotate the crankcase cover (3) 180°. Remount the valve casing together with the seal casing and the seal adapters (20). Make sure that the seal adapters are rotated in order that the bores face downwards.



Preventative Maintenance Check-List & Recommended Spare Parts List						
Check	Daily	Weekly	50hrs	Every 500 hrs	Every 1500 hrs	Every 3000 hrs
Oil Level/Quality	X					
Oil Leaks	X					
Water Leaks	X					
Belts, Pulley		X				
Plumbing		X				
<b>Recommended Spare Parts</b>						
Oil Change			X	X		
Seal Spare Parts (1 kit/pump) (See page 5 for kit list)					X	
Oil Seal Kit (1 kit/pump) (See page 5 for kit list)					X	
Valve Spare Parts (1 kit/pump) (See page 5 for kit list)						X

### P450-5100 PUMP TORQUE SPECIFICATIONS

<u>Position</u>	<u>Item#</u>	<u>Description</u>	<u>Torque Amount</u>
15A	N/A	Screw with Washer	97 lb-in (11 Nm)
16D	08399-0100	Tensioning Screw	221 to 265 lb-in (25-30 Nm)
32	08406-0100	Plug	125 lb-ft (170 Nm)
34	08396-0100	Inner Hexagon Screw	29.5 lb-ft (40 Nm)

---

### Pump Mounting Selection Guide

#### **Bushings**

**07175** - 28 mm Tapered H Bushing

#### **Pulley & Sheaves**

**01055** - 7.75" Cast Iron - 2 gr. - AB Section

**01062** - 7.75" Cast Iron - 2 gr. - AB Section

#### **Rails**

**07358** - Plated Steel Channel Rails

(L=9.18"x W=1.88"x H=3.00")

# PUMP SYSTEM MALFUNCTION

<u>MALFUNCTION</u>	<u>CAUSE</u>	<u>REMEDY</u>
The Pressure and/ or the Delivery Drops	Worn packing seals Broken valve spring Belt slippage Worn or Damaged nozzle Fouled discharge valve Fouled inlet strainer Worn or Damaged hose Worn or Plugged relief valve on pump Cavitation pump for restrictions Unloader	Replace packing seals Replace spring Tighten or Replace belt Replace nozzle Clean valve assembly Clean strainer Repair/Replace hose Clean, Reset, and Replace worn parts Check suction lines on inlet of  Check for proper operation
Water in crankcase	High humidity Worn seals	Reduce oil change interval Replace seals
Noisy Operation	Worn bearings  Cavitation	Replace bearings, Refill crankcase oil with recommended lubricant Check inlet lines for restrictions and/or proper sizing
Rough/Pulsating Operation with Pressure Drop	Worn packing Inlet restriction  Accumulator pressure Unloader Cavitation	Replace packing Check system for stoppage, air leaks, correctly sized inlet plumbing to pump Recharge/Replace accumulator Check for proper operation Check inlet lines for restrictions and/or proper size
Pump Pressure as Rated, Pressure Drop at Gun	Restricted discharge plumbing	Re-size discharge plumbing to Flow Rate of Pump
Excessive Leakage	Worn plungers Worn packing/seals Excessive vacuum Cracked plungers Inlet pressure too high	Replace plungers Adjust or Replace packing seals Reduce suction vacuum Replace plungers Reduce inlet pressure
High Crankcase Temperature	Wrong Grade of oil Improper amount of oil in crankcase	Giant oil is recommended Adjust oil level to proper amount

# P450-5100 PUMP DIMENSIONS - INCHES (MM)

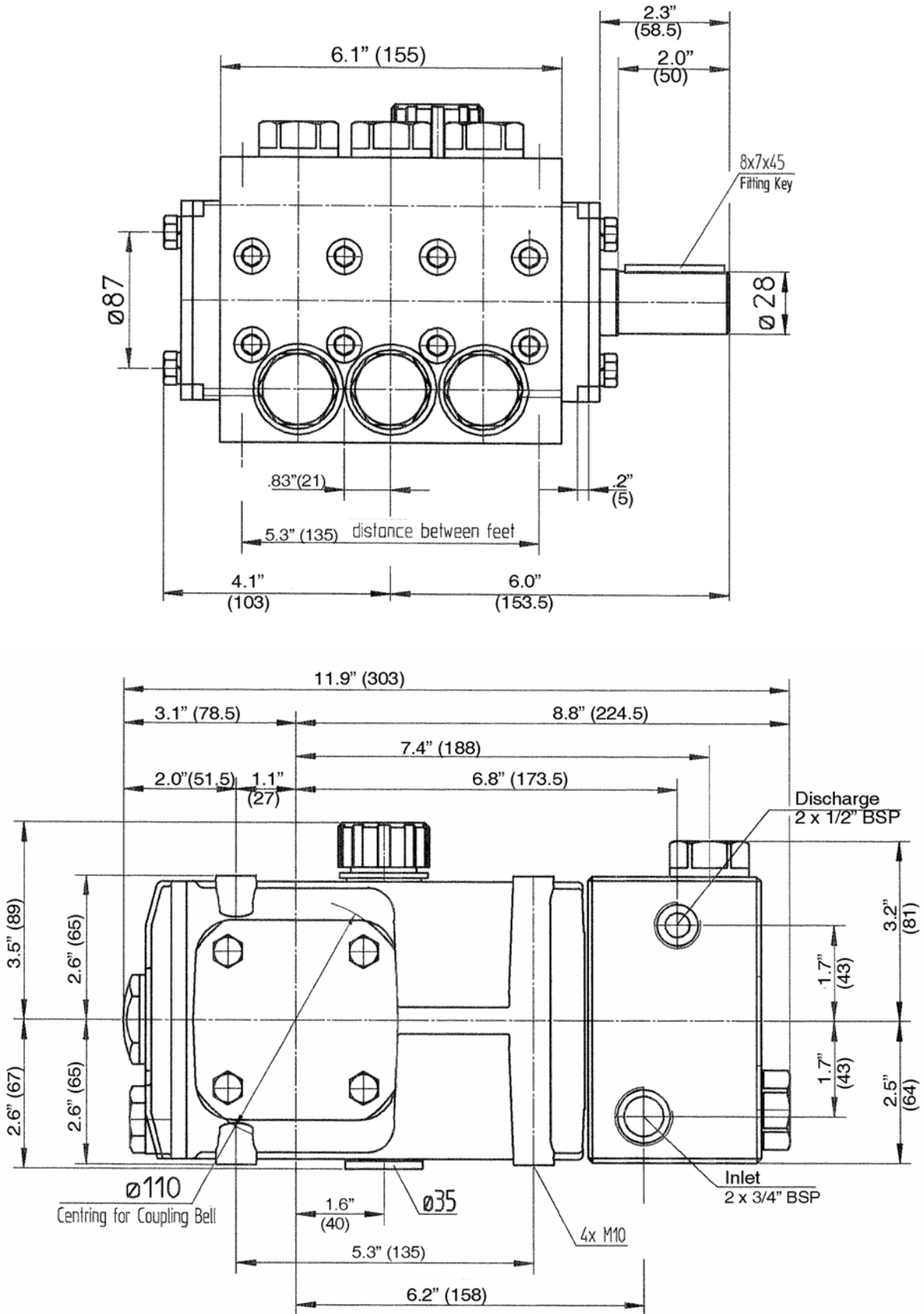

## GIANT INDUSTRIES LIMITED WARRANTY

Giant Industries, Inc. pumps and accessories are warranted by the manufacturer to be free from defects in workmanship and material as follows:

1. For portable pressure washers and self-service car wash applications, the discharge manifolds will never fail, period. If they ever fail, we will replace them free of charge. Our other pump parts, used in portable pressure washers and in car wash applications, are warranted for five years from the date of shipment for all pumps used in NON-SALINE, clean water applications.
2. One (1) year from the date of shipment for all other Giant industrial and consumer pumps.
3. Six (6) months from the date of shipment for all rebuilt pumps.
4. Ninety (90) days from the date of shipment for all Giant accessories.

This warranty is limited to repair or replacement of pumps and accessories of which the manufacturer's evaluation shows were defective at the time of shipment by the manufacturer. The following items are NOT covered or will void the warranty:

1. Defects caused by negligence or fault of the buyer or third party.
2. Normal wear and tear to standard wear parts.
3. Use of repair parts other than those manufactured or authorized by Giant.
4. Improper use of the product as a component part.
5. Changes or modifications made by the customer or third party.
6. The operation of pumps and or accessories exceeding the specifications set forth in the Operations Manuals provided by Giant Industries, Inc.

Liability under this warranty is on all non-wear parts and limited to the replacement or repair of those products returned freight prepaid to Giant Industries which are deemed to be defective due to workmanship or failure of material. A Returned Goods Authorization (R.G.A.) number and completed warranty evaluation form is required prior to the return to Giant Industries of all products under warranty consideration. Call (419)-531-4600 or fax (419)-531-6836 to obtain an R.G.A. number.

Repair or replacement of defective products as provided is the sole and exclusive remedy provided hereunder and the MANUFACTURER SHALL NOT BE LIABLE FOR FURTHER LOSS, DAMAGES, OR EXPENSES, INCLUDING INCIDENTAL AND CONSEQUENTIAL DAMAGES DIRECTLY OR INDIRECTLY ARISING FROM THE SALE OR USE OF THIS PRODUCT.

THE LIMITED WARRANTY SET FORTH HEREIN IS IN LIEU OF ALL OTHER WARRANTIES OR REPRESENTATION, EXPRESS OR IMPLIED, INCLUDING WITHOUT LIMITATION ANY WARRANTIES OR MERCHANTABILITY OR FITNESS FOR A PARTICULAR PURPOSE AND ALL SUCH WARRANTIES ARE HEREBY DISCLAIMED AND EXCLUDED BY THE MANUFACTURER.

