

Pump Models

P400-3100 Series for Seawater Applications

Triplex Ceramic Plunger Pump
Operating Instructions
Repair and Service Manual

P420-3100
P423-3100
P435-3100
P450-3100

Corrosion Resistant Pumps

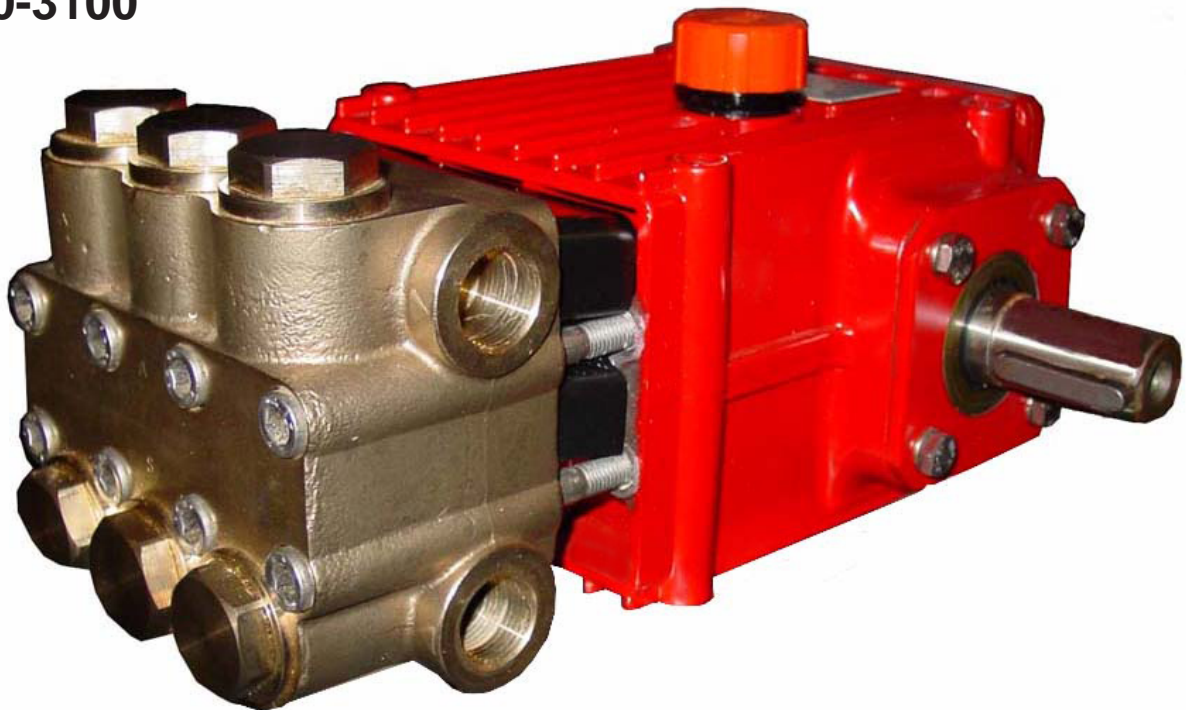

The logo for GIANT, featuring the word "GIANT" in a bold, 3D block font with a black outline and a white fill.

Updated 04/12

Contents:

Installation Instructions:	page 2
Specifications:	page 3
Exploded View:	page 4
Parts List:	page 5
Repair Kits:	page 6
Torque Specifications:	page 6
Recommended Spare Parts:	page 6
Repair Instructions:	pages 7-8
Pump Mounting Selection Guide:	page 8
Trouble Shooting:	page 9
Dimensions:	page 10
Warranty Information:	back page

INSTALLATION INSTRUCTIONS

Installation of the Giant Industries, Inc., pump is not a complicated procedure, but there are some basic steps common to all pumps. The following information is to be considered as a general outline for installation. If you have unique requirements, please contact Giant Industries, Inc. or your local distributor for assistance.

1. The pump should be installed flat on a base to a maximum of a 15 degree angle of inclination to ensure optimum lubrication.
2. The inlet to the pump should be sized for the flow rate of the pump with no unnecessary restrictions that can cause cavitation. Teflon tape should be used to seal all joints. If pumps are to be operated at temperatures in excess of 160° F, it is important to insure a positive head to the pump to prevent cavitation.
3. The discharge plumbing from the pump should be properly sized to the flow rate to prevent line pressure loss to the work area. It is essential to provide a safety bypass valve between the pump and the work area to protect the pump from pressure spikes in the event of a blockage or the use of a shut-off gun.

4. Use of a dampener is necessary to minimize pulsation at drive elements, plumbing, connections, and other system areas. The use of a dampener with Giant Industries, Inc. pumps is optional, although recommended by Giant Industries, Inc. to further reduce system pulsation. Dampeners can also reduce the severity of pressure spikes that occur in systems using a shut-off gun. A dampener must be positioned downstream from the unloader.

5. Crankshaft rotation on Giant Industries, Inc. pumps should be made in the direction designated by the arrows on the pump crankcase. Reverse rotation may be safely achieved by following a few guidelines available upon request from Giant Industries, Inc. Required horsepower for system operation can be obtained from the chart on page 3.

6. Before beginning operation of your pumping system, remember: Check that the crankcase and seal areas have been properly lubricated per recommended schedules. Do not run the pump dry for extended periods of time. Cavitation will result in severe damage. Always remember to check that all plumbing valves are open and that pumped media can flow freely to the inlet of the pump.

Finally, remember that high pressure operation in a pump system has many advantages. But, if it is used carelessly and without regard to its potential hazard, it can cause serious injury.

IMPORTANT OPERATING CONDITIONS

Failure to comply with any of these conditions invalidates the warranty.

1. Prior to initial operation, add oil to the crankcase so that oil level is between the two lines on the oil dipstick. **DO NOT OVERFILL.**

Use SAE 80-90W Oil (Giant's pt. # 01154)

Crankcase oil should be changed after the first 50 hours of operation, then at regular intervals of 500 hours or less depending on operating conditions.

2. Pump operation must not exceed rated pressure, volume, or RPM. A pressure relief device must be installed in the discharge of the system.

3. Acids, alkalines, or abrasive fluids cannot be pumped unless approval in writing is obtained before operation from Giant Industries, Inc.

4. Run the pump dry approximately 10 seconds to drain the water before exposure to freezing temperatures.

NOTE: Contact Giant Industries for Service School Information. Phone: (419)-531-4600

P400 SERIES -- PUMP SPECIFICATIONS

U.S. Measurements

	Max. Flow	Max. Pressure	Max. Speed	Power Req'd.	Max. Temp.	Plunger Diameter	Stroke	Wgt.
Model	GPM	PSI	RPM	HP	F	in	in	lbs
P420-3100	12.8	2175	1450	19.2	86	0.98	0.94	36.6
P423-3100	8.2	2900	1450	16.4	86	0.87	0.79	36.6
P435-3100	6.6	3625	1450	16.5	86	0.71	0.94	37.5
P450-3100	5.5	5075	1450	19.3	86	0.71	0.79	37.5

Metric Measurements

	Max. Flow	Max. Pressure	Max. Speed	Power Req'd.	Max. Temp.	Plunger Diameter	Stroke	Wgt.
Model	L/min	Bar	RPM	kW	C	mm	mm	kg
P420-3100	48.4	150	1450	14.3	30	25	24	16.6
P423-3100	31.1	200	1450	12.2	30	22	20	16.6
P435-3100	25.0	250	1450	12.3	30	18	24	17
P450-3100	20.8	350	1450	14.4	30	18	20	17

Consult the factory for special requirements that must be met if the pump is to operate beyond one or more of the limits specified above.

Horsepower Ratings:

We recommend a 1.15 service factor be specified when selecting an electric motor as the power source.

To compute electric motor horsepower required, use the following formula: $HP = (GPM \times PSI) / 1450$.

The formula to determine the horsepower required for a gas engine is: $HP = (GPM \times PSI) / 1150$.

The formula to determine the horsepower required for a diesel engine is: $HP = (GPM \times PSI) / 1250$.

For the Application of a Hydraulic Motor:

To Determine the Torque of a Hydraulic Motor -- $(GPM \times PSI \times 36.77) / RPM = \text{Torque (in-lbs)}$

Calculating RPM / GPM of Pump:

A pump must be connected to an electric motor or gas or diesel engine with the correct ratio of pulleys and belts to attain the required speed and GPM. The use of a Variable Frequency Drive (VFD) may also be used to control the RPM of a properly sized electric motor when variable flows are required.

$(\text{Max. Pump RPM} / \text{Rated Pump GPM}) \times \text{Required Pump GPM} = \text{Required Pump RPM}$

To calculate a pulley diameter one (1) pulley diameter and the required pump RPM must be known:

$(\text{Pump RPM} \times \text{Pump Pulley Diameter}) / \text{Motor RPM} = \text{Motor Pulley Diameter}$

$(\text{Motor RPM} \times \text{Motor Pulley Diameter}) / \text{Pump RPM} = \text{Pump Pulley Diameter}$

Common Specifications:

Inlet Pressure145 PSI (10 Bar)
 Crankshaft Diameter.....1.1" (28mm)
 Keyway Width.....8mm
 Crankcase Oil Capacity30 fl. oz. (0.89 L)
 Inlet Ports(2) 3/4" [NPT or BSP]*
 Discharge Ports.....(2) 3/4" [NPT or BSP]*
 Shaft Rotation.....Top of Pulley Toward Fluid End

Materials Used for P400-3100 Pumps:

Manifold..... Nickle Aluminum Bronze
 Plungers Solid Ceramic Oxide
 Valves 316 Stainless Steel
 Seals..... Nitrile with Fabric Reinforcing
 Gear End Aluminum

*NPT for pump models P420-3100 & P423-3100,
 BSP for pump models P435-3100 & P450-3100

EXPLODED VIEW - P400-3100 PUMPS

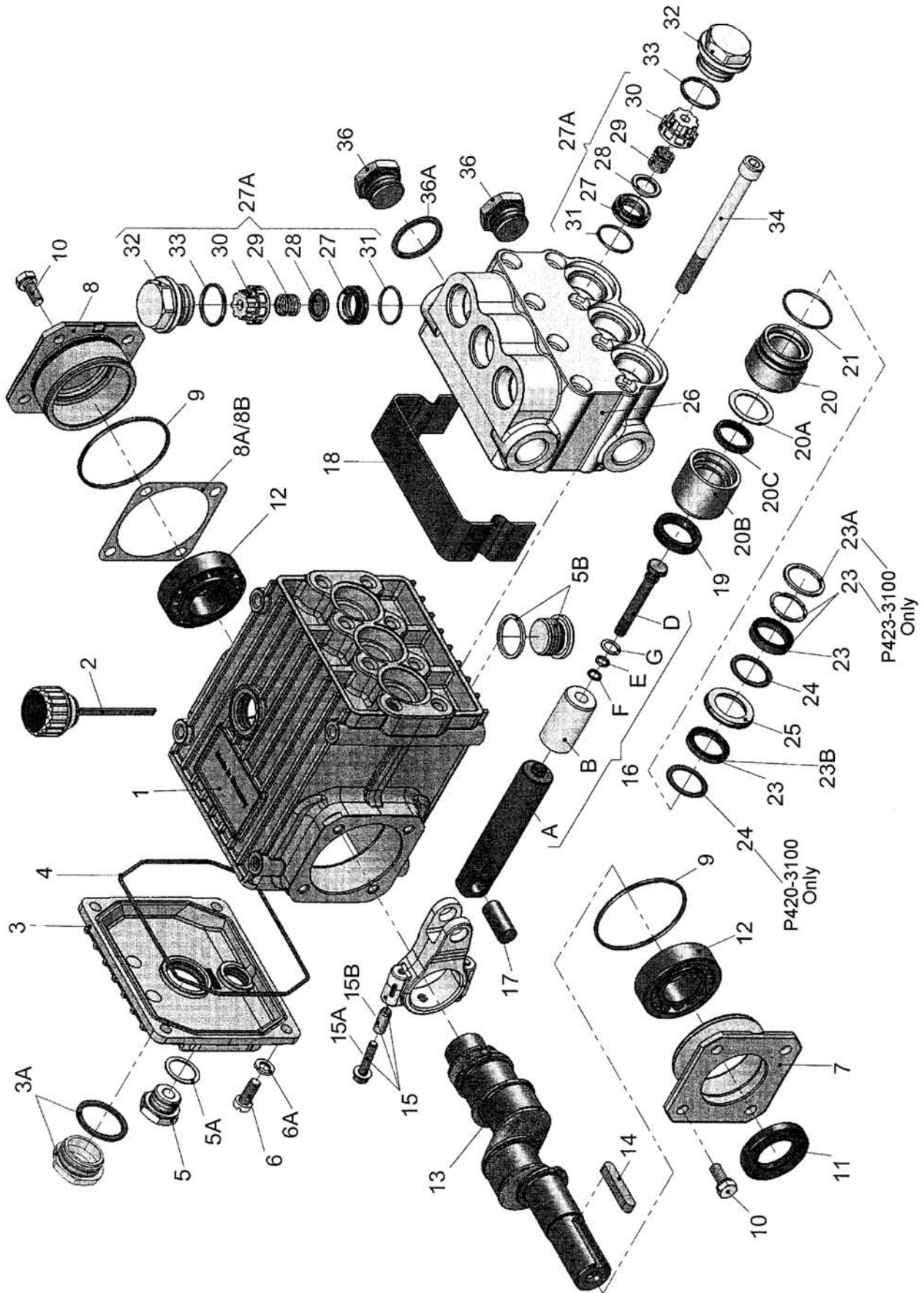

P400-3100 PUMP PARTS LIST

A=P420-3100 B= P423-3100 C=P435-3100 D=P450-3100

<u>ITEM</u>	<u>PART</u>	<u>DESCRIPTION</u>	<u>QTY.</u>	<u>ITEM</u>	<u>PART</u>	<u>DESCRIPTION</u>	<u>QTY.</u>
1	05694	Crankcase	1	20	05601-0100	Seal Case (B)	3
2	08378	Oil Fill Plug with Gasket	1	20	05534-0100	Seal Case (C,D)	3
3	05689	Crankcase cover	1	20A	05696	Spacer Ring	3
3A	07186	Oil Sight Glass w/ Gasket	1	20B	05695	Extended Sleeve	3
4	08380	O-Ring	1	20C	06182	Guide Ring for 20B	3
5	07109-0400	Oil Drain Plug	1	21	07266-0001	O-Ring	3
5A	07182	Gasket for Oil Drain Plug	1	23	12254	Grooved Seal (A)	3
5B	08092-0100	Plug with Gasket	1	23	06249	Grooved Seal (B)	3
6	01010-0100	Screw	4	23	08477	Grooved Seal (C,D)	6
6A	01011-0400	Spring Washer	12	23A	06251-0100	Spacer Disc (B)	3
7	05690	Bearing Cover	1	23B	12255	Grooved Seal (A)	3
8	05974	Bearing Cover	1	23B	13390	Grooved Seal (B)	3
8A	05292	Shim	1-3	24	08376	Support Ring (A)	6
8B	05293	Shim	1	24	06252	Support Ring (B)	3
9	01016	O-Ring	2	24	07929	Support Ring (C,D)	3
10	07114-0100	Screw with Washer	8	25	06804	Weep Return Ring (A)	3
11	07459	Radial Shaft Seal	1	25	06254-0100	Weep Return Ring (B)	3
12	05350	Bearing	2	25	08402-0300	Weep Return Ring (C,D)	3
13	08475	Crankshaft (A,C)	1	26	08395-3000	Manifold (A,B)	1
13	08482	Crankshaft (B,D)	1	26	05574-3000	Manifold (C,D)	1
14	08091	Fitting Key	1	27A	08408-0100	Valve Assembly (A,B)	6
15	08390	Connecting Rod Assembly	3	27A	05578	Valve Assembly (C,D)	6
15A	05349	Connecting Rod Screw	6	27	08370-0100	Valve Seat (A,B)	6
15B	05348	Adapter Sleeve	6	27	05576	Valve Seat (C,D)	6
16	06178	Plunger Assy. Items 16A-16G (A)	3	28	06791-0100	Valve Plate (A,B)	6
16	05693	Plunger Assy. Items 16A-16G (B)	3	28	05542-0100	Valve Plate (C,D)	6
16	05692	Plunger Assy. Items 16A-16G (C,D)	3	29	06377-0100	Valve Spring (A,B)	6
16A	06179	Plunger Base	3	29	07906-0100	Valve Spring (C,D)	6
16B	08398	Plunger Pipe (A)	3	30	08372	Valve Spring Retainer (A,B)	6
16B	06247	Plunger Pipe (B)	3	30	07907	Valve Spring Retainer (C,D)	6
16B	08397	Plunger Pipe (C,D)	3	31	07212-0001	O-Ring, Viton (A,B)	6
16D	08399-0100	Tensioning Screw	3	31	07770-0001	O-Ring (C,D)	6
16E	07023-0001	O-Ring	3	32	06616	Plug (A,B)	6
16F	07203	Backup Ring	3	32	08406	Plug (C,D)	6
16G	07161-0100	Steel Washer	3	33	07214-0001	O-Ring, Viton (A,B)	6
17	06790	Crosshead Pin	3	33	06015-0001	O-Ring (C,D)	6
18	06180	Cover	1	34	06183	Inner Hexagon Screw	8
19	05444	Oil Seal	3	36	13150-0100	Plug, 3/4" BSP (C, D)	2
20	05443-0100	Seal Case (A)	3	36A	06808	Steel Seal Ring (C, D)	1

P400-3100 SERIES PUMP REPAIR KITS

Plunger Packing Kits

09667 (P420-3100)

Item	Part #	Description	Qty.
20C	06182	Guide Ring	3
21	07266-0001	O-Ring	3
23	12254	Grooved Seal	3
23B	12255	Grooved Seal	3
24	08376	Support Ring	6

Oil Seal Kit

09641

Item	Part #	Description	Qty.
19	05444	Oil Seal	3

Plunger Packing Kits

09668 (P423-3100)

Item	Part #	Description	Qty.
20C	06182	Guide Ring	3
21	07266-0001	O-Ring	3
23	06249	Grooved Seal	3
23B	13390	Grooved Seal	3
24	06252	Support Ring	3

Valve Assembly Kit

09522 (P420A-3100, P423-3100)

Item	Part #	Description	Qty.
27A	08408-0100	Valve Assy, Complete	6
33	07214-0001	O-Ring, Viton	6

Plunger Packing Kit

09634 (P435-3100, P450-3100)

Item	Part #	Description	Qty.
20C	06182	Guide Ring	3
21	07266-0001	O-Ring	3
23	08477	Grooved Seal	6
24	07929	Support Ring	3

Valve Assembly Kit

09142-0100 (P435-3100, P450-3100)

Item	Part #	Description	Qty.
27A	05578	Valve Assy, Complete	6
33	06015-0001	O-Ring	6

P400-3100 PUMP TORQUE SPECIFICATIONS

Item #	Part #	Description	Torque Amount
15A	05349	Screw with Washer	97 in.-lbs.(11 NM)
16D	08399-0100	Tensioning Screw	265 in.-lbs.(30 NM)
32	06616	Plug (P420-3100/P423-3100)	107 ft.-lbs.(145 NM)
32	08406	Plug (P435-3100/P450-3100)	125 ft.-lbs. (170 NM)
34	06183	Inner Hexagon Screw	30 ft.-lbs.(40 NM)

Preventative Maintenance Check-List & Recommended Spare Parts List

Check	Daily	Weekly	50hrs	Every 500 hrs	Every 1500 hrs	Every 3000 hrs
Oil Level/Quality	X					
Oil Leaks	X					
Water Leaks	X					
Belts, Pulley		X				
Plumbing		X				
Recommended Spare Parts						
Oil Change			X	X		
Seal Spare Parts (1 kit/pump) (See above for kit list)					X	
Oil Seal Kit (1 kit/pump) (See above for kit list)					X	
Valve Spare Parts (1 kit/pump) (See above for kit list)						X

REPAIR INSTRUCTIONS - P400-3100

Note: Always take time to lubricate all metal and nonmetal parts with a light film of oil before reassembly. This step will ensure proper fit, at the same time protecting the pump nonmetal parts (i.e., the elastomers) from cutting and scoring.

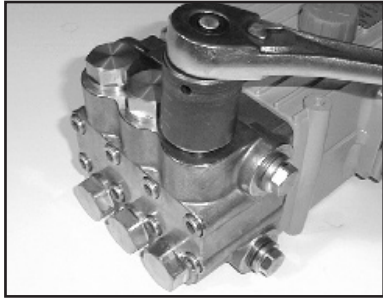

- 1) With a socket wrench, remove the three discharge valve plugs and three inlet valve plugs (32). Inspect the o-ring (33) for wear and replace if damaged.

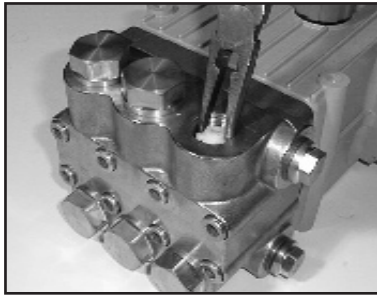

- 2) Using needle nose pliers, remove the inlet and discharge valve assemblies (27A). Note: It may become necessary to remove the valve seat (27) from the valve casing using a slidehammer.

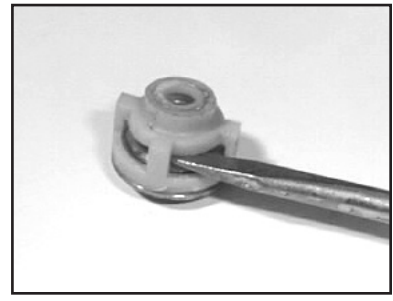

- 3) By inserting a small screw driver between the valve seat (27) and the valve spring retainer (30), the valve assembly can be separated.

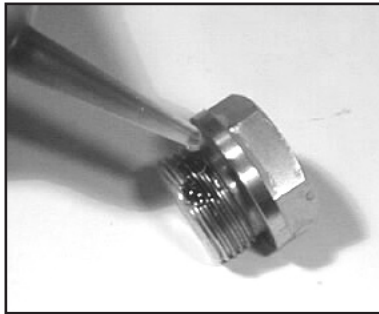

- 4) Remove the o-ring (31). Inspect all parts for wear and replace as necessary. Apply one drop of Loctite 243 to the valve plugs (32) and tighten to 107 ft.-lbs. (145 Nm) for P420-3100/ P423-3100 and 125 ft.-lbs (170 Nm) for P435-3100/ P450-3100).

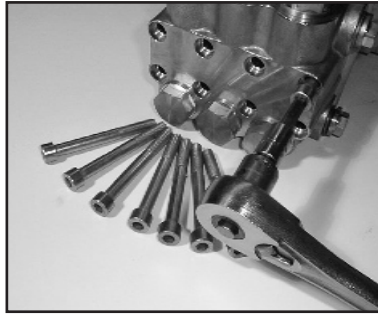

- 5) Use a 8mm allen wrench to remove the 8 socket head cap screws (34). Carefully slide the valve casing (26) out over the plungers.

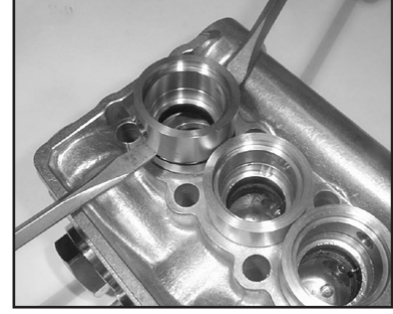

- 6) Remove seal case (20) and weep return rings (25) from the valve casing.

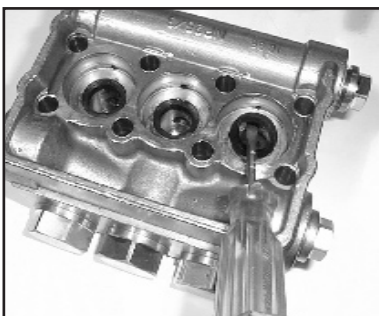

- 7) Remove the pressure rings (24) and v-sleeves (23 - Note: P423-3100 pumps have a support ring) from the valve casing (26).



- 8) Remove the weep grooved seal (23 or 23B) together with pressure ring (24 - P420 -3100 only) out of the seal case (20). Check O-rings (21).

IMPORTANT! The grooved seal (23) or respectively grooved seal pack (23A) on the high-pressure side is to be fitted carefully into the valve casing (26) using a screwdriver. Under no circumstances must the seal surface in the valve casing or the seal lip be damaged.

REASSEMBLY INSTRUCTIONS - P400-3100

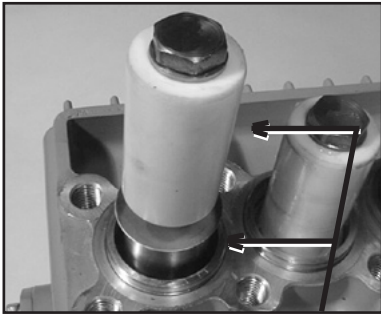

- 9) Check surfaces of plunger (16). Damaged surfaces cause accelerated seal wear. Deposits of all kinds must be removed from the plungers.

IMPORTANT! Plunger surfaces are not to be damaged. If there are lime deposits in the pump, care must be taken that the drip-return bore in parts (25) and (26) ensure trouble-free drip-return.

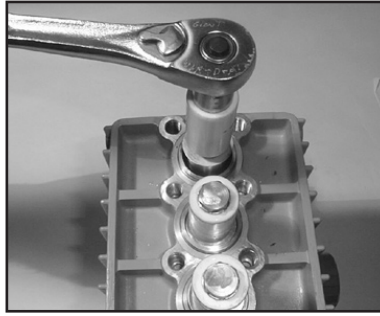

- 10) If the plunger pipe (16B), or oil seal (19) is worn, remove tension screw (16D) and remove along with plunger pipe (16B). Check and clean plunger surface (16A). If necessary, replace oil seals (19) with seal lips facing crankcase (1). Cover thread of tension screw (16D) with a thin film of Loctite and tighten carefully to 265 in.-lbs. (30 Nm).

IMPORTANT! Care must be taken that glue does not get between the plunger pipe (16B) and centring sleeve (16C). The plunger pipe should not be strained by eccentric tightening of the tension screw or through damage to front surface of plunger, otherwise it is liable to fracture.

- 11) After installation of high pressure seals (23). Place seal case (20) with weep seals & pressure ring installed, weep return ring (25) and high pressure weep return ring (24) over plungers. Slide valve casing over plungers and seat firmly. Replace the 8 socket head cap screws (34) and tighten to 30 ft.-lbs. (40 Nm) in a crossing pattern (as shown below).

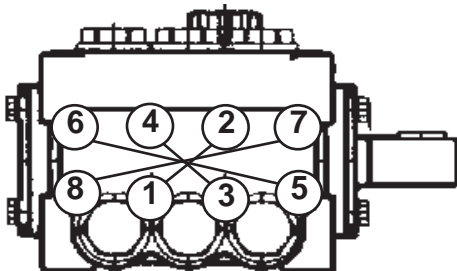

Pump Mounting Selection Guide

Bushings

07175 - 28 mm Tapered H Bushing

Pulley & Sheaves

01055 - 7.75" Cast Iron - 2 gr. - AB Section

01062 - 7.75" Cast Iron - 2 gr. - AB Section

Rails

07358 - Plated Steel Channel Rails
(L=9.18"x W=1.88"x H=3.00")

Contact Giant Industries for service school information. Phone: (419) 531-4600

PUMP SYSTEM MALFUNCTION

<u>MALFUNCTION</u>	<u>CAUSE</u>	<u>REMEDY</u>
The Pressure and/or the Delivery Drops	Worn packing seals Broken valve spring Belt slippage Worn or Damaged nozzle Fouled discharge valve Fouled inlet strainer Worn or Damaged hose Worn or Plugged relief valve on pump Cavitation Unloader	Replace packing seals Replace spring Tighten or Replace belt Replace nozzle Clean valve assembly Clean strainer Repair/Replace hose Clean, Reset, and Replace worn parts Check suction lines on inlet of pump for restrictions Check for proper operation
Water in crankcase	High humidity Worn seals	Reduce oil change interval Replace seals
Noisy Operation	Worn bearings Cavitation	Replace bearings, Refill crankcase oil with recommended lubricant Check inlet lines for restrictions and/or proper sizing
Rough/Pulsating Operation with sure Drop	Worn packing Inlet restriction Accumulator pressure Unloader Cavitation	Replace packing Check system for stoppage, air leaks, correctly sized inlet plumbing to pump Recharge/Replace accumulator Check for proper operation Check inlet lines for restrictions and/or proper size
Pump Pressure as Rated, Pressure Drop at gun	Restricted discharge plumbing	Re-size discharge plumbing to flow rate of pump
Excessive Leakage	Worn plungers Worn packing/seals Excessive vacuum Cracked plungers Inlet pressure too high	Replace plungers Adjust or Replace packing seals Reduce suction vacuum Replace plungers Reduce inlet pressure
High Crankcase Temperature	Wrong Grade of oil Improper amount of oil in crankcase	Giant oil is recommended Adjust oil level to proper amount

P400-3100 Pump Dimensions - inches (mm)

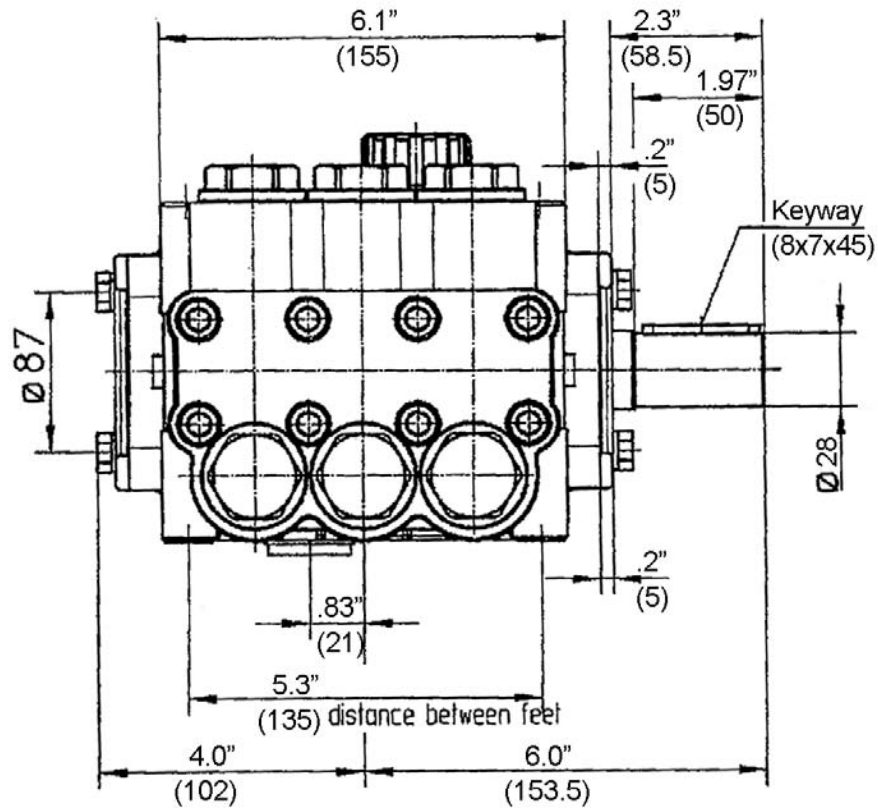
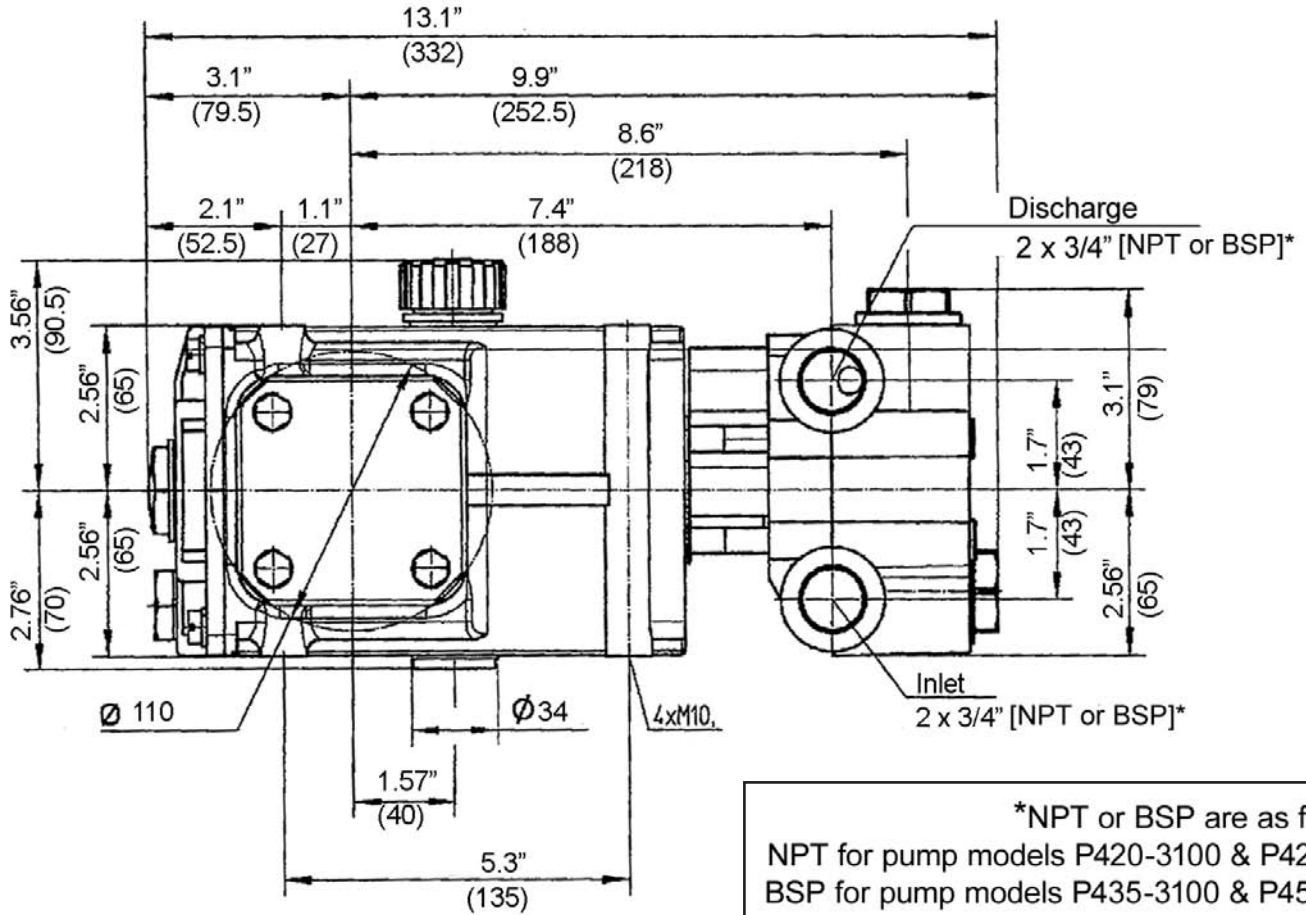

NOTES

GIANT INDUSTRIES LIMITED WARRANTY

Giant Industries, Inc. pumps and accessories are warranted by the manufacturer to be free from defects in workmanship and material as follows:

1. For portable pressure washers and self-service car wash applications, the discharge manifolds will never fail, period. If they ever fail, we will replace them free of charge. Our other pump parts, used in portable pressure washers and in car wash applications, are warranted for five years from the date of shipment for all pumps used in NON-SALINE, clean water applications.
2. One (1) year from the date of shipment for all other Giant industrial and consumer pumps.
3. Six (6) months from the date of shipment for all rebuilt pumps.
4. Ninety (90) days from the date of shipment for all Giant accessories.

This warranty is limited to repair or replacement of pumps and accessories of which the manufacturer's evaluation shows were defective at the time of shipment by the manufacturer. The following items are NOT covered or will void the warranty:

1. Defects caused by negligence or fault of the buyer or third party.
2. Normal wear and tear to standard wear parts.
3. Use of repair parts other than those manufactured or authorized by Giant.
4. Improper use of the product as a component part.
5. Changes or modifications made by the customer or third party.
6. The operation of pumps and or accessories exceeding the specifications set forth in the Operations Manuals provided by Giant Industries, Inc.

Liability under this warranty is on all non-wear parts and limited to the replacement or repair of those products returned freight prepaid to Giant Industries which are deemed to be defective due to workmanship or failure of material. A Returned Goods Authorization (R.G.A.) number and completed warranty evaluation form is required prior to the return to Giant Industries of all products under warranty consideration. Call (419)-531-4600 or fax (419)-531-6836 to obtain an R.G.A. number.

Repair or replacement of defective products as provided is the sole and exclusive remedy provided hereunder and the MANUFACTURER SHALL NOT BE LIABLE FOR FURTHER LOSS, DAMAGES, OR EXPENSES, INCLUDING INCIDENTAL AND CONSEQUENTIAL DAMAGES DIRECTLY OR INDIRECTLY ARISING FROM THE SALE OR USE OF THIS PRODUCT.

THE LIMITED WARRANTY SET FORTH HEREIN IS IN LIEU OF ALL OTHER WARRANTIES OR REPRESENTATION, EXPRESS OR IMPLIED, INCLUDING WITHOUT LIMITATION ANY WARRANTIES OR MERCHANTABILITY OR FITNESS FOR A PARTICULAR PURPOSE AND ALL SUCH WARRANTIES ARE HEREBY DISCLAIMED AND EXCLUDED BY THE MANUFACTURER.



GIANT INDUSTRIES, INC., 900 N. Westwood Ave., Toledo, Ohio 43607
PHONE (419) 531-4600, FAX (419) 531-6836, www.giantpumps.com