

P200-3100 SERIES PUMPS 18mm Versions

Triplex Ceramic
Plunger Pump
Operating Instructions/
Repair and Service Manual

Nickle-Aluminum Bronze Models:

P217-3100, P218-3100, P219-3100,
P220-3100, P221-3100, P227-3100,
P230-3100



Updated 11/11

Contents:

Installation Instructions:	page 2
Pump Specifications:	page 3
Exploded View:	page 4
Parts List / Kits:	page 5
Torque Specifications:	page 5
Repair Instructions:	pages 6-7
Dimensions:	back page
Warranty Information:	back page

INSTALLATION INSTRUCTIONS

Installation of the Giant Industries, Inc., pump is not a complicated procedure, but there are some basic steps common to all pumps. The following information is to be considered as a general outline for installation. If you have unique requirements, please contact Giant Industries, Inc. or your local distributor for assistance.

1. The pump should be installed flat on a base to a maximum of a 15 degree angle of inclination to ensure optimum lubrication.

2. The inlet to the pump should be sized for the flow rate of the pump with no unnecessary restrictions that can cause cavitation. Teflon tape should be used to seal all joints. If pumps are to be operated at temperatures in excess of 160° F, it is important to insure a positive head to the pump to prevent cavitation.

3. The discharge plumbing from the pump should be properly sized to the flow rate to prevent line pressure loss to the work area. It is essential to provide a safety bypass valve between the pump and the work area to protect the pump from pressure spikes in the event of a blockage or the use of a shut-off gun.

4. Use of a dampener is necessary to minimize pulsation at drive elements, plumbing, connections, and other system areas. The use of a dampener with Giant Industries, Inc. pumps is optional, although recommended by Giant Industries, Inc. to further reduce system pulsation. Dampeners can also reduce the severity of pressure spikes that occur in systems using a shut-off gun. A dampener must be positioned downstream from the unloader.

5. Crankshaft rotation on Giant Industries, Inc. pumps should be made in the direction designated by the arrows on the pump crankcase. Reverse rotation may be safely achieved by following a few guidelines available upon request from Giant Industries, Inc. Required horsepower for system operation can be obtained from the charts on pages 3-9.

6. Before beginning operation of your pumping system, remember: Check that the crankcase and seal areas have been properly lubricated per recommended schedules. Do not run the pump dry for extended periods of time. Cavitation will result in severe damage. Always remember to check that all plumbing valves are open and that pumped media can flow freely to the inlet of the pump.

Finally, remember that high pressure operation in a pump system has many advantages. But, if it is used carelessly and without regard to its potential hazard, it can cause serious injury.

IMPORTANT OPERATING CONDITIONS

Failure to comply with any of these conditions invalidates the warranty.

1. Prior to initial operation, add oil to the crankcase so that oil level is between the two lines on the oil dipstick. **DO NOT OVERFILL.**

Use Giant recommended Oil P/N 01153 (20W-50)

Crankcase oil should be changed after the first 50 hours of operation, then at regular intervals of 500 hours or less depending on operating conditions.

2. Pump operation must not exceed rated pressure, volume, or RPM. A pressure relief device must be installed in the discharge of the system.

3. Acids, alkalines, or abrasive fluids cannot be pumped unless approval in writing is obtained before operation from Giant Industries, Inc.

4. Run the pump dry approximately 10 seconds to drain the water before exposure to freezing temperatures.

P200-3100 Series - 18mm Versions- Pump Specifications

U.S. Measurements

	Max. Flow	Maximum Pressure	Max. Speed	Power Req'd.	Max. Temperature	Plunger Diameter	Stroke	NPSH Required
Model	GPM	PSI	RPM	BHP	F	in	in	Ft-Head
P230-3100	1.1	2000	1750	1.5	86	0.71	0.13	n/a
P217-3100	1.85	2000	1750	2.6	86	0.71	0.22	n/a
P227-3100	2.1	2000	1750	2.9	86	0.71	0.25	n/a
P230-3100	2.1	2000	3450	2.9	86	0.71	0.13	n/a
P221-3100	2.34	2000	1750	3.32	86	0.71	0.28	n/a
P218-3100	3.4	2000	1750	4.7	86	0.71	0.39	21.0
P217-3100	3.6	2000	3450	5	86	0.71	0.42	n/a
P227-3100	3.8	2000	3450	5.2	86	0.71	0.25	n/a
P219-3100	4.2	2000	1750	5.8	86	0.71	0.49	21.0
P220-3100	4.7	2000	1750	6.5	86	0.71	0.56	21.6

Metric Measurements

	Max. Flow	Maximum Pressure	Max. Speed	Power Req'd.	Max. Temperature	Plunger Diameter	Stroke	NPSH Required
Model	L/min	Bar	RPM	kW	C	mm	mm	mWs
P230-3100	4.2	140	1750	2.0	30	18	3.4	n/a
P217-3100	7.0	140	1750	3.5	30	18	5.5	n/a
P227-3100	7.9	140	1750	3.9	30	18	6.3	n/a
P230-3100	7.9	140	3450	3.9	30	18	3.4	n/a
P221-3100	8.9	140	1750	4.5	30	18	7	n/a
P218-3100	12.9	140	1750	6.3	30	18	10	6.4
P217-3100	13.6	140	3450	6.7	30	18	5.5	n/a
P227-3100	14.4	140	3450	7.0	30	18	6.3	n/a
P219-3100	15.9	140	1750	7.8	30	18	12.4	6.4
P220-3100	17.8	140	1750	8.7	30	18	14.1	6.6

Horsepower Ratings:

We recommend a 1.15 service factor be specified when selecting an electric motor as the power source. To compute electric motor horsepower required, use the following formula: $HP = (GPM \times PSI) / 1450$. The formula to determine the horsepower required for a gas engine is: $HP = (GPM \times PSI) / 1150$. The formula to determine the horsepower required for a diesel engine is: $HP = (GPM \times PSI) / 1250$.

For the Application of a Hydraulic Motor:

To Determine the Torque of a Hydraulic Motor -- $(GPM \times PSI \times 36.77) / RPM = \text{Torque (in-lbs)}$

Calculating RPM / GPM of Pump:

A pump must be connected to an electric motor or gas or diesel engine with the correct ratio of pulleys and belts to attain the required speed and GPM. The use of a Variable Frequency Drive (VFD) may also be used to control the RPM of a properly sized electric motor when variable flows are required.

$$(\text{Max. Pump RPM} / \text{Rated Pump GPM}) \times \text{Required Pump GPM} = \text{Required Pump RPM}$$

To calculate a pulley diameter one (1) pulley diameter and the required pump RPM must be known:

$$(\text{Pump RPM} \times \text{Pump Pulley Diameter}) / \text{Motor RPM} = \text{Motor Pulley Diameter}$$

$$(\text{Motor RPM} \times \text{Motor Pulley Diameter}) / \text{Pump RPM} = \text{Pump Pulley Diameter}$$

Materials Used for P200-3100 Pumps:

Manifold Nickle-Aluminum Bronze
 Plungers Solid Ceramic Oxide
 Valves 316 Stainless Steel
 Seals Nitrile with Fabric Reinforcing
 Gear End Anodized Aluminum

Common Specifications:

Max. Inlet Pressure..... 145 PSI (10 Bar)
 Crankshaft Diameter..... 0.94" (24mm)
 Oil Capacity (short)..... 7.5 fl. oz. (0.2 L)
 Oil Capacity (extended)..... 9.0 fl. oz. (0.3 L)
 Inlet Ports (2) 1/2" BSP
 Discharge Ports (2) 3/8" BSP
 Weight 13.4 lbs (6.0 kg)
 Shaft Rotation Top of Pulley Towards Fluid End

Exploded View - P200A-3100 Series

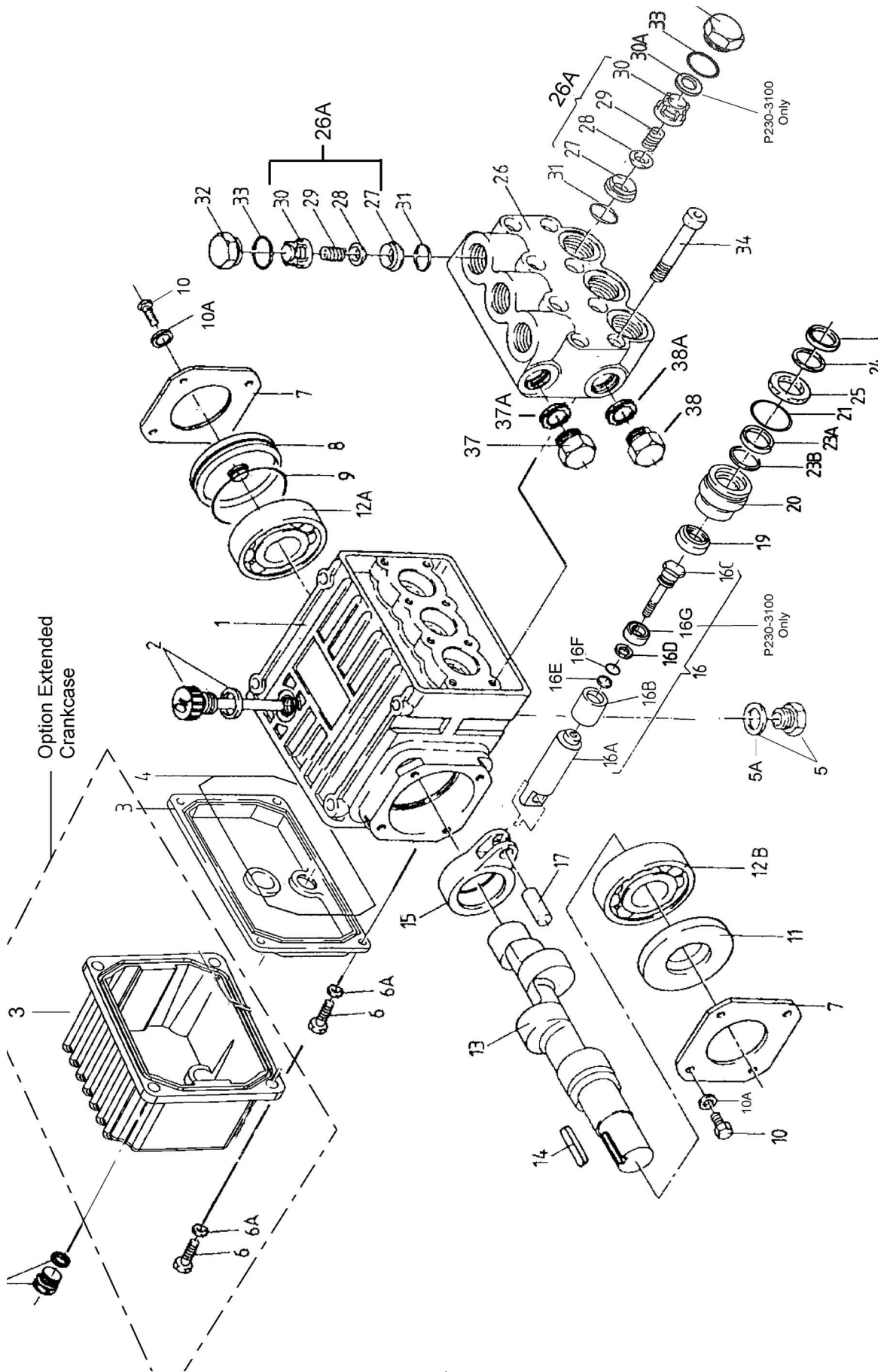

P200A-3100 SERIES PARTS LIST

<u>ITEM</u>	<u>PART NO.</u>	<u>DESCRIPTION</u>	<u>QTY.</u>	<u>ITEM</u>	<u>PART NO.</u>	<u>DESCRIPTION</u>	<u>QTY.</u>
1	08300A	Crankcase, Anodized	1	16C	08456-0100	Tension Screw, 316 S.S.	3
2	08301	Dipstick	1	16D	07204-0100	Crush Washer, 316 S.S.	3
3	08302A	Crankcase Cover, Anodized	1	16E	07203	Support Ring,	3
3	08302-L	Crankcase Cover, Long (Optional)	1	16F	07023	O-Ring,	3
3A	07190-0100	Drain Plug & Gasket	1	16G	06823	Plunger Extension, P230-3100 Only	3
4	08005	O-Ring	1	17	08442	Wrist Pin	3
5	08185-0100	Oil Drain Plug with seal	1	19	08356	Oil Seal	3
5A	08192	Gasket	1	20	08444A-0100	Seal Retainer, 316 S.S.	3
6	07188-0100	Screw, 316 S.S.	4	21	12260-0001	O-Ring	3
6A	07223-0100	Spring Washer, 316 S.S.	4	23	06704*	Grooved Seal	3
7	08303	Bearing Cover I	2	23A	08087	Grooved Seal Ring, Brown	3
8	08490	Sight Glass	1	23B	06163	Drip Shield	3
9	08492	O-Ring	1	24	07904	Pressure Ring	3
10	07225-0100	Screw	8	25	08445-0100	Weep Return Ring, 316 S.S.	3
10A	07223-0100	Spring Washer	8	26	06582-3000	Valve Casing	1
11	01166	Radial Shaft Seal	1	26A	07946-0100	Valve Assembly,(27-30/31/33) Except P230-3100	6
12A	08020	Ball Bearing	1	27	07849-0100	Valve Seat	6
12B	01020	Ball Bearing	1	28	06809	Valve Plate	6
13	08465	Crankshaft (P217A-3100)	1	29	07906-0100	Valve Spring, except P230-3100	6
13	08440	Crankshaft (P218A-3100)	1	29	06816	Valve Spring, P230-3100 Only	6
13	08466	Crankshaft (P219A-3100)	1	30	07907	Valve Spring Retainer	6
13	08467	Crankshaft (P220A-3100)	1	30A	06824	Spacer Ring, P230-3100 Only	3
13	12258	Crankshaft (P221A-3100)	1	31	7853-0001	O-Ring	6
13	06547	Crankshaft (P227A-3100)	1	32	07928-0300	Plug	6
13	06694	Crankshaft (P230A-3100)	1	33	07913-0001	O-Ring	6
14	06207	Fitting Key	1	34	08316-0100	Hex Head Cap Screw	8
15	08333	Connecting Rod	3	37	13338-0300	Plug, 3/8" BSP	1
16	08469-0100	Plunger Assembly, Except P230-3100	3	37A	08486	Copper Washer, 3/8"	1
16	06641-0100	Plunger Assembly P230-3100 Only	3	38	07109-0300	Plug, 1/2" BSP	1
16A	08468-0100	Plunger Base, 316 S.S.	3	38A	06272	Copper Washer, 1/2"	1
16B	08455	Plunger Pipe	3	*p/n 08477 might also be used in this position			

P200A-3100 SERIES REPAIR KITS

Plunger Packing Kit

Part# 09602

<u>Item</u>	<u>Part #</u>	<u>Description</u>	<u>Qty.</u>
23	08477*	Grooved Seal	3
23A	08087	Grooved Seal Ring	3
23B	06163	Drip Shield	3
24	07904	Pressure Ring	3

*p/n 06704 can also be used in this position

Oil Seal Kit

Part# 09144

<u>Item</u>	<u>Part #</u>	<u>Description</u>	<u>Qty.</u>
19	08356	Oil Seal	3

Valve Assembly Kits

Part # 09714 - Except P230-3100

<u>Item</u>	<u>Part #</u>	<u>Description</u>	<u>Qty.</u>
26A	07946-0100	Valve Assembly	6
33	07913-0001	O-Ring	6

Part # 09139 - P230-3100 Only

<u>Item</u>	<u>Part #</u>	<u>Description</u>	<u>Qty.</u>
27	07849-0100	Valve Seat	6
28	06809	Valve Plate	6
29	06816	Valve Spring	6
30	07907	Valve Retainer	6
31	07853-0001	O-Ring	6
33	07913-0001	O-Ring	6

P200A-3100 SERIES TORQUE SPECIFICATIONS

<u>Position</u>	<u>Item#</u>	<u>Description</u>	<u>Torque Amount</u>
16C	08456-0100	Tension Screw, Plunger	220 in.-lbs. (24.9 NM)
32	07928-0100	Valve Plug	33 ft.-lbs (44.7 NM)
34	08316-0100	Hex Head Cap Screw, Valve Casing	105 in.-lbs. (11.8 NM)

REPAIR INSTRUCTIONS - P200A-3100 SERIES

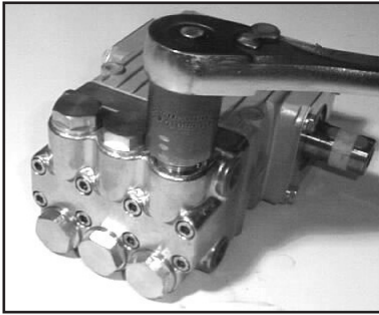

1. With a 22mm socket wrench, remove the (3) discharge valve plugs and (3) inlet valve plugs (32). Inspect the o-ring (33) for wear and replace if damaged.

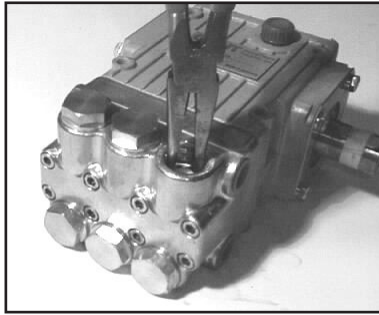

2. Using a needle nose pliers, remove the inlet and discharge valve assemblies (27-30), for P230-3100 only, remove spacer (30A), and o-ring (31). Inspect all parts for wear and replace as necessary.

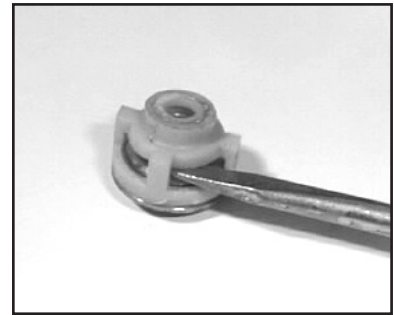

3. By inserting a small screw driver between the valve seat (27) and the valve spring retainer (30), the valve assembly can be separated.



4. Apply one drop of Loctite 243 to the valve plugs (32) and tighten to 33 ft.-lbs.

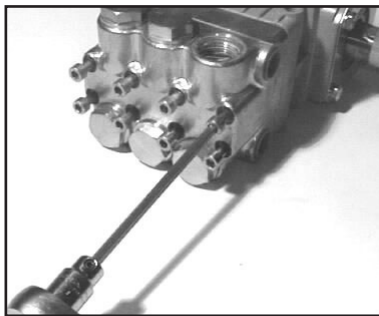

5. Next, use a 5mm allen wrench to remove the 8 socket head cap screws (34).

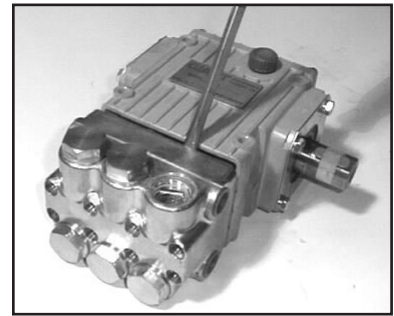

6. Carefully slide the valve casing (26) out over the plungers.



7. Remove the weep return ring (25), pressure ring (24), and v-sleeve (23) from the valve casing (26). Remove the rear v-sleeve (23A) from the seal case (20). Inspect all parts, including o-ring (21) for wear and replace as necessary.

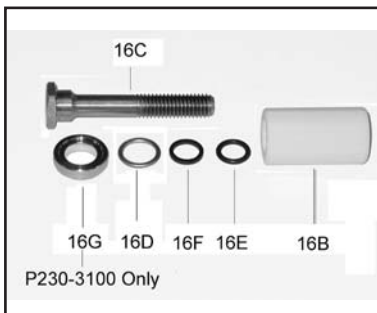

8. Check surfaces of plunger pipe (16B). A damaged surface will cause accelerated wear on the seals. Deposits of any kind must be carefully removed from the plunger surface. A damaged plunger must be replaced! **When replacing the crush washer (item 16D), make sure the rolled side of the crush washer is placed on the ceramic. Prior to installation, carefully crush the seal ring on a hand press.**



9. If the crankcase oil seals (19) are to be replaced, they can be removed by prying loose with a flat screwdriver. Take care not to make contact with the plunger.

REPAIR INSTRUCTIONS - P200A-3100 SERIES

Disassembly sequence of the *back* end of the P200A-3100 series pump.

- 1) Before you begin, drain the oil from the crankcase.
- 2) Remove the crankcase cover (3) and o-ring (4) from the crankcase (1). To remove the crankshaft (13), remove the bearing cover (7) and sight glass (8). Using a rubber mallet, remove the crankshaft axially through the connecting rods by tapping on the end of the shaft. Be careful not to bend or damage the connecting rods during crankshaft removal.
- 3) If the bearings (12A and 12B) and radial shaft seal (11) are still in the crankcase, remove them. Inspect both bearings and seal for wear and replace if necessary.
- 4) Remove the connecting rod (15) and plunger assembly (16). Remove the wrist pin (17) if necessary. Check the plunger bore in the crankcase for wear. Inspect parts and replace as necessary.
- 5) Should you find it necessary to service the plunger assembly (16) you can do so by removing the tension screw (16C). Replace crush washer (16D). **NOTE: Carefully flatten crush washer before replacing it.** Inspect all parts and replace as necessary.

Reassembly sequence of the P200A-3100 series pump

- 1) Reassemble plunger assembly (16) (apply a drop of Loctite to the tension screw (16C) threads) and the connecting rod (15) with wrist pin (17). Place assemblies in crankcase (1). Install crankshaft through connecting rods again being careful not to bend or otherwise damage the connecting rods.
- 2) Replace left and right side bearings (12A and 12B) if they were removed from the crankshaft. Be certain the bearings are pressed all the way onto the shaft and completely into the crankcase. Replace radial shaft seal (11), bearing cover (7), sight glass (8), and crankcase cover (3) with its o-ring (4).
- 3) If oil seals (19) were removed, replace with seal lip towards crankcase. Lubricate seal before replacing.
- 4) Replace seal case (20) with o-rings (21) over plungers. Generously lubricate o-rings and oil seal before reassembly. Replace drip shield (23B) and v-sleeve (23A) over plungers (16)..
- 5) Generously lubricate v-sleeve (23) and assemble into valve casing (26). Assemble weep return ring (25) and pressure ring (24) over plungers (16). Slide valve casing over plungers and seat firmly. Replace the eight socket head cap screws (34) and tighten to 105 inch-pounds in a crossing pattern (see below).
- 6) Re-install the six o-rings (31) and the six valve assemblies (27-30), and spacer ring (16D), P230-3100 only. Now replace the six valve plugs with o-rings (32 and 33) and tighten securely with a 22mm socket wrench to 33 foot-pounds.
- 7) Fill crankcase with 8.1 ounces of oil.

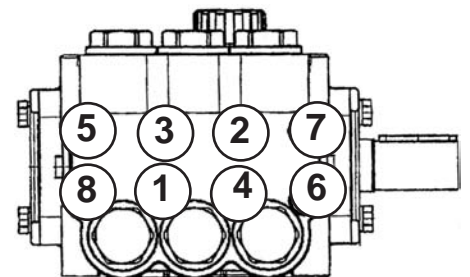

Pump Mounting Selection Guide

Bushings 07174 - 24 mm Tapered H Bushing
Pulley & Sheaves 01061 - 7.75" Cast Iron - 1 gr. - AB Section 01062 - 7.75" Cast Iron - 2 gr. - AB Section
Rails 01160 - Plated Steel Channel Rails (L=5.75"x W-1.0"XH=1.812") 01161 - Plated Steel Channel Rails (L=5.75"x W-1.0"XH=2.50")

P200A-3100 DIMENSIONS - INCHES (mm)

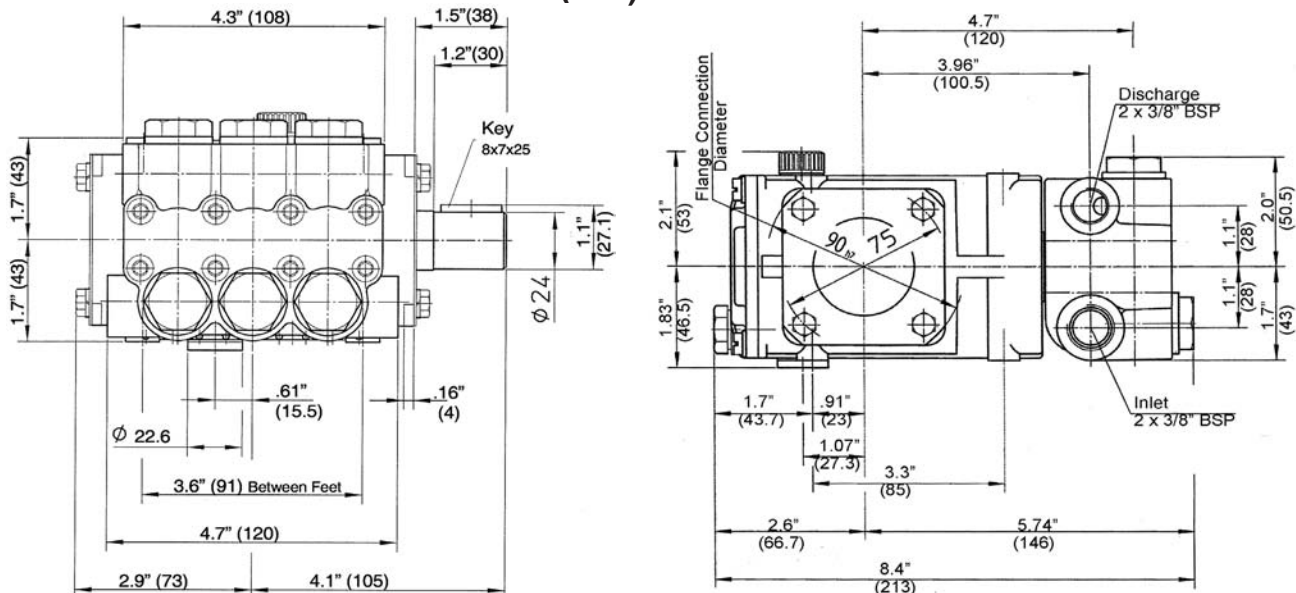

GIANT INDUSTRIES LIMITED WARRANTY

Giant Industries, Inc. pumps and accessories are warranted by the manufacturer to be free from defects in workmanship and material as follows:

1. For portable pressure washers and self-serve car wash applications, the discharge manifolds will never fail, period. If they ever fail, we will replace them free of charge. Our other pump parts, used in portable pressure washers and in car wash applications, are warranted for five years from the date of shipment for all pumps used in NON-SALINE, clean water applications.
2. One (1) year from the date of shipment for all other Giant industrial and consumer pumps.
3. Six (6) months from the date of shipment for all rebuilt pumps.
4. Ninety (90) days from the date of shipment for all Giant accessories.

This warranty is limited to repair or replacement of pumps and accessories of which the manufacturer's evaluation shows were defective at the time of shipment by the manufacturer. The following items are NOT covered or will void the warranty:

1. Defects caused by negligence or fault of the buyer or third party.
2. Normal wear and tear to standard wear parts.
3. Use of repair parts other than those manufactured or authorized by Giant.
4. Improper use of the product as a component part.
5. Changes or modifications made by the customer or third party.
6. The operation of pumps and or accessories exceeding the specifications set forth in the Operations Manuals provided by Giant Industries, Inc.

Liability under this warranty is on all non-wear parts and limited to the replacement or repair of those products returned freight prepaid to Giant Industries which are deemed to be defective due to workmanship or failure of material. A Returned Goods Authorization (R.G.A.) number and completed warranty evaluation form is required prior to the return to Giant Industries of all products under warranty consideration. Call (419)-531-4600 or fax (419)-531-6836 to obtain an R.G.A. number.

Repair or replacement of defective products as provided is the sole and exclusive remedy provided hereunder and the MANUFACTURER SHALL NOT BE LIABLE FOR FURTHER LOSS, DAMAGES, OR EXPENSES, INCLUDING INCIDENTAL AND CONSEQUENTIAL DAMAGES DIRECTLY OR INDIRECTLY ARISING FROM THE SALE OR USE OF THIS PRODUCT.

THE LIMITED WARRANTY SET FORTH HEREIN IS IN LIEU OF ALL OTHER WARRANTIES OR REPRESENTATION, EXPRESS OR IMPLIED, INCLUDING WITHOUT LIMITATION ANY WARRANTIES OR MERCHANTABILITY OR FITNESS FOR A PARTICULAR PURPOSE AND ALL SUCH WARRANTIES ARE HEREBY DISCLAIMED AND EXCLUDED BY THE MANUFACTURER.



GIANT INDUSTRIES, INC., 900 N. Westwood Ave., Toledo, Ohio 43607
 Phone (419) 531-4600, Fax (419) 531-6836, www.giantpumps.com
 © Copyright 2010 Giant Industries, Inc.