

Models

Triplex Ceramic
Plunger Pump
Operating Instructions/
Repair and Service
Manual

MP4130-3100 & MP4135-3100

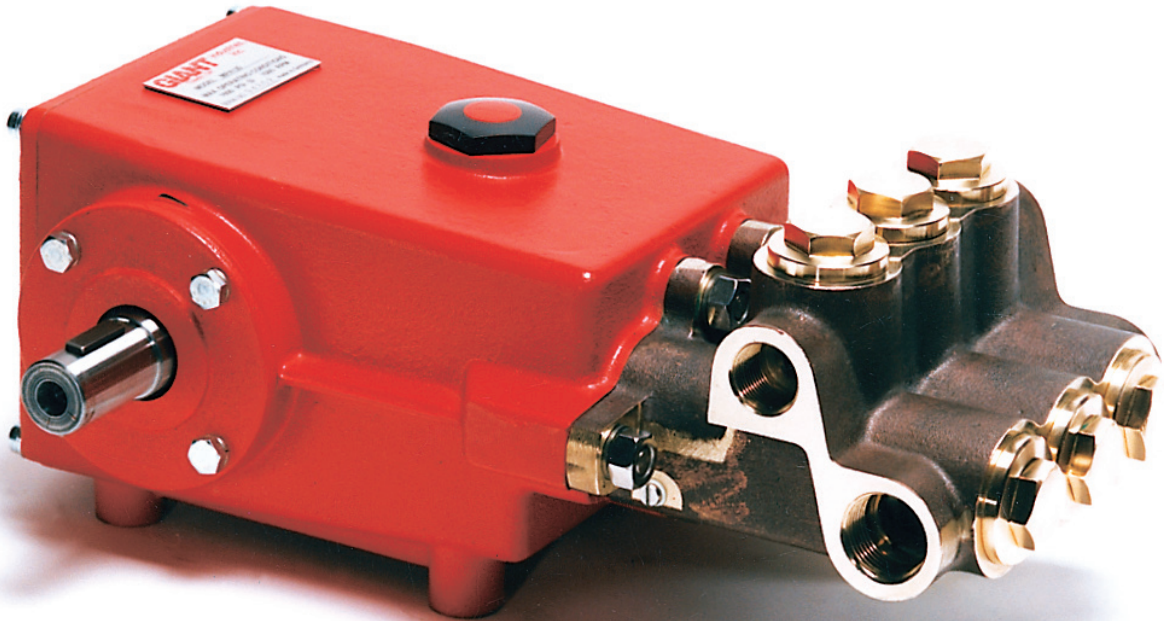

Contents:

Installation Instructions:	page 2
Pump Specifications:	page 3
Exploded View:	page 4
Parts List / Kits:	page 5
Repair Instructions:	page 6-10
Torque Specifications:	page 10
Pump Mounting Selection Guide:	page 10
Troubleshooting/Recommended Spare Parts List:	page 11
Dimensions:	back page
Warranty Information:	back page

Updated 07/12

INSTALLATION INSTRUCTIONS

Installation of the Giant Industries, Inc., pump is not a complicated procedure, but there are some basic steps common to all pumps. The following information is to be considered as a general outline for installation. If you have unique requirements, please contact Giant Industries, Inc. or your local distributor for assistance.

1. The pump should be installed flat on a base to a maximum of a 15 degree angle of inclination to ensure optimum lubrication.
2. The inlet to the pump should be sized for the flow rate of the pump with no unnecessary restrictions that can cause cavitation. Teflon tape should be used to seal all joints. Maximum inlet fluid temperature is 160° F (71° C).
3. The discharge plumbing from the pump should be properly sized to the flow rate to prevent line pressure loss to the work area. It is essential to provide a safety bypass valve between the pump and the work area to protect the pump from pressure spikes in the event of a blockage or the use of a shut-off gun.

4. Use of a dampener is necessary to minimize pulsation at drive elements, plumbing, connections, and other system areas. The use of a dampener with Giant Industries, Inc. pumps is optional, although recommended by Giant Industries, Inc. to further reduce system pulsation. Dampeners can also reduce the severity of pressure spikes that occur in systems using a shut-off gun. A dampener must be positioned downstream from the unloader.

5. Crankshaft rotation on Giant Industries, Inc. pumps should be made in the direction designated by the arrows on the pump crankcase. Reverse rotation may be safely achieved by following a few guidelines available upon request from Giant Industries, Inc. Required horsepower for system operation can be obtained from the charts on page 3.

6. Before beginning operation of your pumping system, remember: Check that the crankcase and seal areas have been properly lubricated per recommended schedules. Do not run the pump dry for extended periods of time. Cavitation will result in severe damage. Always remember to check that all plumbing valves are open and that pumped media can flow freely to the inlet of the pump.

Finally, remember that high pressure operation in a pump system has many advantages. But, if it is used carelessly and without regard to its potential hazard, it can cause serious injury.

IMPORTANT OPERATING CONDITIONS

Failure to comply with any of these conditions invalidates the warranty.

1. Prior to initial operation, add oil to the crankcase so that oil level is between the two lines on the oil dipstick. **DO NOT OVERFILL.**

Use SAE 80W-90 Industrial Gear Lube Oil (Giant's p/n 01154)

Crankcase oil should be changed after the first 50 hours of operation, then at regular intervals of 500 hours or less depending on operating conditions.

2. Pump operation must not exceed rated pressure, volume, or RPM. A pressure relief device must be installed in the discharge of the system.

3. Acids, alkalines, or abrasive fluids cannot be pumped unless approval in writing is obtained before operation from Giant Industries, Inc.

4. Run the pump dry approximately 10 seconds to drain the water before exposure to freezing temperatures.

MP4130-3100 & MP4135-3100 Pump Specifications

	U.S.	Metric
Volume (MP4130-3100).....	15.4 GPM	58.2 L/min
Volume (MP4135-3100).....	17.9 GPM	67.7 L/min
Discharge Pressure	1600 PSI.....	110 Bar
Inlet Pressure	90 PSI	6.2 Bar
Speed	Up to 1100 RPM	
Plunger Diameter.....	1.2"	30mm
Plunger Stroke (MP4130-3100).....	1.0"	26mm
Plunger Stroke (MP4135-3100).....	1.8"	30mm
Crankcase Oil Capacity	33.8 fl.oz.	1 Liter
Temperature of Pumped Fluids	Up to 158° F	70° C
Inlet Ports	(2) 1" NPT	
Discharge Ports	(2) 3/4" NPT	
Pulley Mounting.....	Either side	
Shaft Rotation.....	Top of Pulley Towards Fluid End	
Weight	66 lbs.	30 Kg
Crankshaft Diameter.....	1.1"	28mm

Consult the factory for special requirements that must be met if the pump is to operate beyond one or more of the limits specified above.

PULLEY INFORMATION

Pulley selection and pump speed are based on a 1725 PRM motor and "B" section belts. When selecting desired GPM, allow for a ±5% tolerance on pumps output due to variations in pulleys, belts and motors among manufacturers.

1. Select GPM required, then select appropriate motor pulley from the same line.
2. The desired pressure is achieved by selecting the correct nozzle size that corresponds with the pump GPM.

HORSEPOWER RATINGS:

The rating shown are the power requirements for the pump. Gas engine power outputs must be approximately twice the pump power requirements shown above.

We recommend a 1.15 service factor be specified when selecting an electric motor as the power source. To compute specific pump horsepower requirements, use the following formula:
 $HP = (GPM \times PSI) / 1450$

MP4130-3100 Horsepower Requirements					
RPM	GPM	500 PSI	1000 PSI	1300 PSI	1600 PSI
700	9.8	3.4	6.8	8.8	10.8
800	11.2	3.9	7.7	10.0	12.4
900	12.6	4.3	8.7	11.3	13.9
1000	14.0	4.8	9.7	12.6	15.4
1100	15.4	5.3	10.6	13.8	17.0

MP4135-3100 Horsepower Requirements					
RPM	GPM	500 PSI	1000 PSI	1300 PSI	1600 PSI
700	11.4	3.9	7.9	10.2	12.6
800	13.0	4.5	9.0	11.7	14.4
900	14.6	5.1	10.1	13.1	16.2
1000	16.3	5.6	11.2	14.6	18.0
1100	17.9	6.2	12.3	16.0	19.8

MP4130-3100 & MP4135-3100 Spare Parts List

<u>ITEM</u>	<u>PART #</u>	<u>DESCRIPTION</u>	<u>QTY.</u>	<u>ITEM</u>	<u>PART #</u>	<u>DESCRIPTION</u>	<u>QTY.</u>
1	06100	Crankcase	1	30	06136	Flinger	3
2	13000	Oil Filler Cap Assy	1	31	07260	Crankcase Oil Seal	3
4	07243	Cover, Crankcase	1	36	07267-0100	Snap Ring	3
5	07244	O-Ring, Crankcase Cover	1	39	07271	Pressure Ring	6
8	01008	Oil Dip Stick	1	40	07272	V-Sleeve	9
9	01009	O-Ring, Dip Stick	1	41	07273	Support Ring	6
10	01010	Hexagon Socket Screw	4	42	07353	Tension Spring	3
11	08094	Spring Washer	12	42A	06103	Tension Plug	3
12	12137	Oil Drain Plug	1	42B	06736	O-Ring, Tension Plug	3
13	07182	Gasket, Oil Drain Plug	1	43	04152	Valve Casing	1
14	07245	Bearing Cover	2	44	07280-0100	Valve Seat	6
15	07247	Seal, Crankshaft	2	44A	06003-0001	O-Ring, Valve Seat	6
16	07627	O-Ring	2	45	07282	Valve Plate	6
17	08095	Hex Screw, Bearing Cover	9	46	07283	Valve Spring	6
20	07248	Roller Bearing, Tapered	2	47	04153	Spring Tension Cap	3
20A	07249	Shim	1-3	48	06964	Plug	3
20B	06962	Fitting Disc	2	48A	06965	O-Ring, Plug	3
21	05375	Shaft Protector	1	49	06139	Stud Bolt	6
22	07251	Crankshaft (MP4130-3100)	1	49A	06140	Fitting Sleeve w/ Extension	2
22	04149	Crankshaft (MP4135-3100)	1	49B	06141	Extension	4
23	13331	Key	1	49C	07319	Hexagon Nut	2
24	07253	Connecting Rod Assembly	3	50	07158	Nut, Manifold Stud	6
24A	05349	Hex Screw with Washer	6	50A	07159	Spring Washer	6
25	07254	Crosshead Assembly	3	51	06110-0100	Spacer	3
28	07255	Crosshead Pin	3	52	06112-0100	Valve Housing	3
29A	07256	Centering Sleeve	3	53	06965	O-Ring	3
29B	07261	Plunger Pipe	3	54	04154	Spring Tension Disc	3
29C	04150	Tension Screw	3	55	06357-0100	Plug, 1" BSP	1
29D	07161-0100	Steel Ring	3	56	13150-0100	Plug, 3/4" BSP	1
29E	04151	Plunger Extension	3	57	13020	Disc for Crankshaft	1
				62	06142	Tin Lid	1

MP4130-3100 & MP4135-3100 SERIES REPAIR KITS

Valve Kit

Part # 09581

<u>Item #</u>	<u>Part #</u>	<u>Description</u>	<u>Qty.</u>
44	07280-0100	Valve Seat	6
44A	06003-0001	O-Ring	6
45	07282	Valve Plate	6
46	07283	Valve Spring	6
47	04153	Spring Tension Cap	3
48A	06965	O-Ring, Plug	3
53	06965	O-Ring	3
54	04154	Spring Tension Disc	3

Seal Kit

Part # 09580

<u>Item #</u>	<u>Part #</u>	<u>Description</u>	<u>Qty.</u>
40	07272	V-Sleeve	9
42B	06736	O-Ring	3
53	06965	O-Ring	3

REPAIR INSTRUCTION - MP4130-3100 & MP4135-3100

Disassembly sequence of the GIANT MP4130-3100 & MP4135-3100 Series Pumps

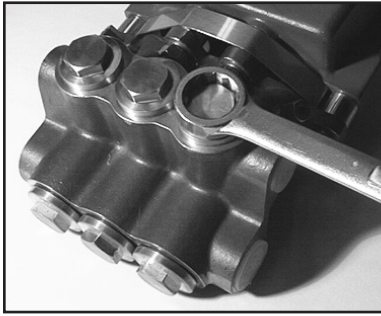

1. With a 27mm wrench, remove the three discharge plugs (#48) and three inlet plugs (#42A) from the manifold (#43).

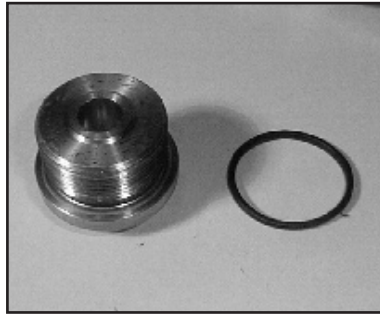

2. Inspect the plug o-rings (#48A and #42B) and replace as necessary.

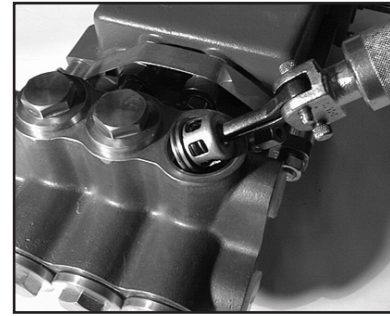

3. Using a valve puller (available from Snap-On-Tools), remove the valve assembly (#44 - #47).

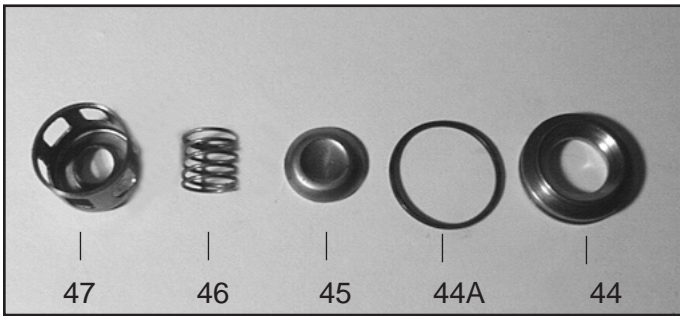

4. Inspect all parts, especially the seating surface of the valve plate (#45), and replace as necessary.

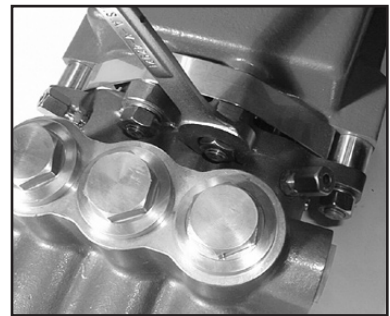

5. Remove the six manifold stud nuts (#50) with a 19mm wrench. Remove the spring washers (#50A). Tap the back of the manifold with a rubber mallet to dislodge and slide it off the studs (#49).

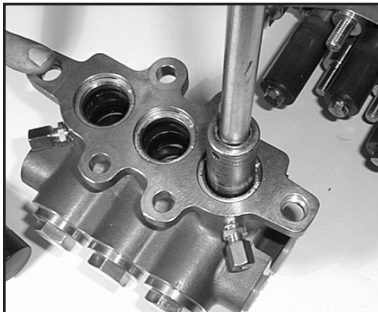

6. To remove the inlet valve assembly, insert a 13mm socket with extension through the rear of the inlet manifold (#43) port and tap it firmly with a hammer. This will force the tension spring (#46), valve housing (#52) and the remainder of the inlet valve assembly out through the front of the inlet port.

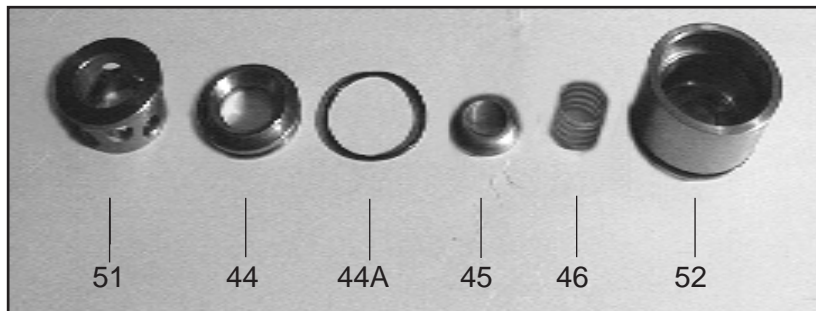

7. Pull the inlet valve assembly apart for inspection. Any resistance may be overcome by placing the valve housing (#52) in a brass jawed vise and carefully tapping the back of the valve plate (#45) with a screwdriver. Remove the spacer pipe (#51) valve seats (#44), o-ring (#44A), valve plate (#45), spring (#46), replace them as necessary.

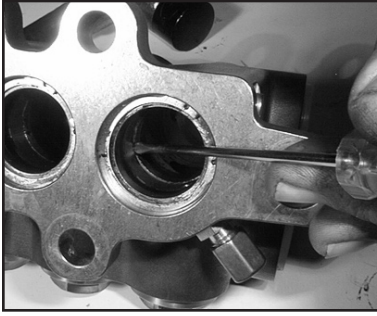

8. From the back of the manifold (#43), remove the packing assembly (#'s 42, 41, 40, and 39) by tapping assembly out from the back to the front.

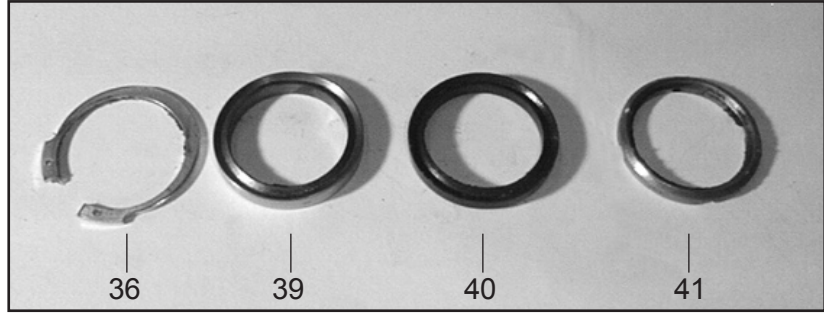

9. Turn the manifold (#43) over and remove the rear v-sleeve snap ring (#36). Remove rear pressure ring (#39), rear v-sleeve (#40) and rear support ring (#41). These parts should slide out with little resistance. If necessary, a screwdriver may be used to pry outward. Replace all rubber parts and inspect the metal parts for wear.

10. **Note: The following procedure is only necessary if a stud bolt (#49) has been damaged and must be replaced.** To remove the manifold studs (#49), place a stud nut (#50), lock washer (#50A), and second nut on each stud. Tighten the nuts against each other. Hold the front nut with one wrench, and remove the stud bolt by turning the rear nut counterclockwise with another wrench. To reassemble, turn the front stud bolt nut clockwise.

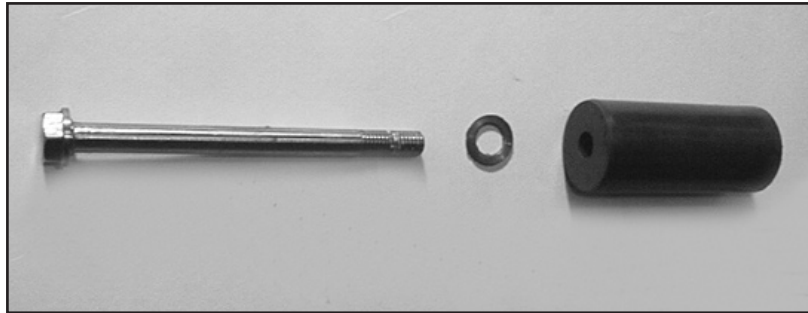

11. To remove the ceramic plungers, turn the plunger bolt (#29C) counterclockwise with a 13mm socket. Use a steady torque to prevent ceramic plunger sleeve damage. Loosen and remove the plunger bolt assembly (#29C and #29D) and replace the seal washer (#29D).

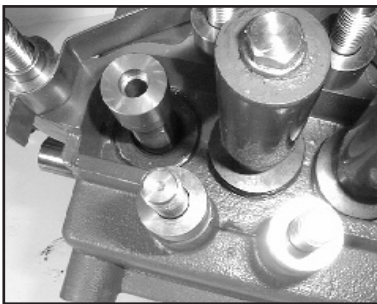

11a. Inspect the crankcase oil seals (#31) for evidence of leaking. If there is oil on the crankcase (#1) at the sight of the oil seals, they must be replaced. The oil seals are replaced after removing the crosshead/plunger assembly (#25) as described below.

Contact Giant Industries for service school information. Phone: (419) 531-4600

Gear End Disassembly

Note: Make certain that the plungers (29B) have been removed before starting the following sequence.

12. Make sure the oil is drained from the pump before removing the crankcase cover (#4). Remove all screws (#10). Inspect the crankcase cover o-ring (#5) for damage and replace it as necessary.
13. Remove the connecting rod screws and washers (#'s 24A and 24B) with a 6mm allen wrench. Remove the back halves of each connecting rod (#24) . Push the connecting rods down as far as possible into the crankcase (#1) housing. **Note that the connecting rod halves are numbered (or colored) and that the numbers (or colors) must be matched for reassembly.**
14. Remove the crankshaft bearing cover screws (#17) with a 13mm wrench. Remove the key (#23) from the crankshaft (#22).
15. Remove the bearing cover (#14) and any shims (#20A) if any. **Remember to replace shims on the same side of the crankcase (#1) during the reassembly.**
16. Steady the pump gear end and, using a rubber mallet, tap the crankshaft (#22) from one side. The far side bearing race will be removed and the near side race will remain in the crankcase. The roller bearings (#20) will remain on the crankshaft. When both ends are free, the crankshaft can be removed by hand.
17. To remove the remaining bearing race, place a dowel against the inside edge of the race and tap it out with a rubber mallet. This is done only if the race wear surface has been damage.
18. Inspect the bearing race removed with the crankshaft (#22) and replace if wear surface is damaged.
19. **Note: The following procedure is only necessary if the inspection shows evidence of heavy wear.** Inspect the crankshaft (#22) and bearings (#20) for wear. To remove the roller bearings from the crankshaft, use a three inch push puller with a pulley attachment. To remount the bearings, tap the bearings down the well-lubricated crankshaft with the Giant Bearing Tool. Be sure that the bearing is firmly seated.
20. Remove the connecting rod (#24) with the attached crosshead/plunger assembly (#25) from the crankcase (#1) by pulling it straight out. The oil seals (#31) may now be removed by tapping them out through the front of the crankcase. Be careful not to damage the snap ring.
21. Inspect the surfaces of the crosshead/plunger assembly (#25) and connecting rods (#24) for heavy scoring or galling due to poor lubrication. Check for play at the joint between connecting rod crosshead/plunger assembly.
22. To remove the crosshead pin (#28) from the crosshead/plunger assembly (#25), the assembly should be positioned in such a manner to prevent damage to the crosshead when driving the pin out. The crosshead pin can be driven out by tapping on the tapered side of the pin

Reassembly sequence

Note: Always take time to lubricate all metal and nonmetal parts with a light film of oil before reassembly. This step will help ensure a proper fit, at the same time it will protect the pump nonmetal parts (elastomers) from cutting and scoring.

23. Take the crosshead/plunger rod assembly and insert the connecting rod (#24) into the crosshead/plunger assembly (#25). Drive the tapered end of the crosshead pin (#28) into the beveled side of the crosshead and through the connecting rod completing the assembly.

Note: The crosshead pin should not extend beyond either side of the crosshead in order to prevent damage to the crosshead bore of the crankcase.

24. Inspect the crankcase crosshead guides for any possible damage.
25. Replace the connecting rod (#24), crosshead/plunger rod assembly (#25) into the crankcase (#1).
26. If removed previously, replace the far side bearing race into the crankcase. Tap with a rubber mallet until the edges are flush with the crankcase surface.
27. Remove the old crankshaft seal (#15) from the bearing cover (#14). Lubricate the edges of the new seal and install using the standard Giant Bearing Tool. Remove the bearing tool and tap around the perimeter of the seal with a rubber mallet to firmly seat the seal. Position the far bearing cover on the crankcase (#1) and insert the cover bolts (#17). Tighten the cover evenly to the crankcase, setting the bearing into position. Torque the cover bolts to 125 inch-pounds (14 Nm).
28. Insert the crankshaft (#22) with the mounted bearings (#20) through the near side of the crankcase (#1). **Make certain that the numbers (or colors) or the crankshaft correspond to the numbers (or colors) on the connecting rods (#24).** Reinstall the near side bearing race by inserting it into the crankcase. Supporting the crankshaft with one hand, tap the race with a rubber mallet until the edge is flush with the crankcase.

29. Replace any shims (#20A) and position the bearing cover (#14) as before. Tighten the bearing cover bolts (#17) evenly to position the bearing race. Torque the bolts to 125 inch-pounds. Once the crankshaft reassembly is complete, oil the crankshaft races freely before replacing the connecting rod (#24) end caps.
30. Reassemble the connecting rods (#24), matching the numbered (or colored) halves. Torque the connecting rod bolts (#24A) to 250 inch-pounds (28 Nm).
31. To replace the oil seal (#31) apply locktite to the outside edges of the seal and install from the front of the crankcase (#1). The side of the seal with the spring must face the oil. Make sure that the face of the seal is flush with the crankcase.

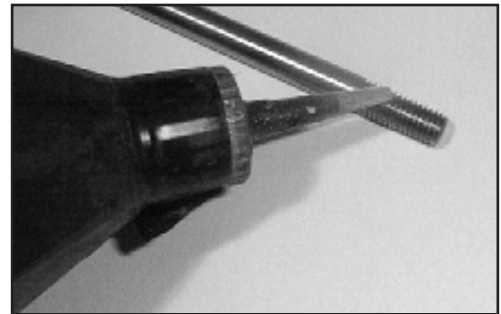
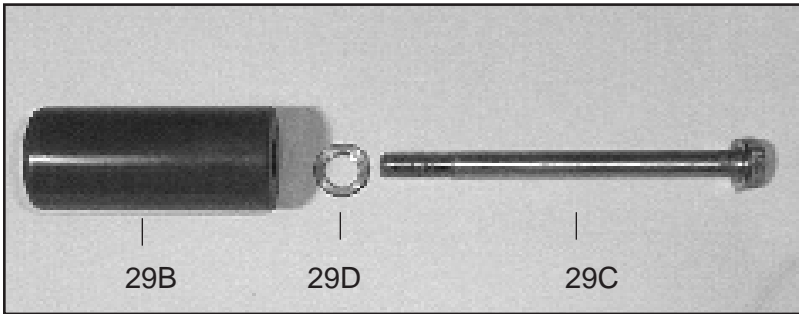

32. Inspect the ceramic plungers (#29B) and replace them if necessary. Clean the ends of the ceramic and remount onto the crosshead/plunger assembly. Make certain that the end of the plunger which is not counter-bored is facing the discharge side of the pump. Install the seal washer (#29D) on the bolt assembly.

33. Clean the bolt threads (#29C), apply locktite, and remount.

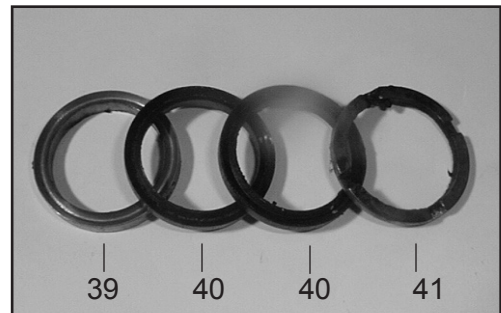
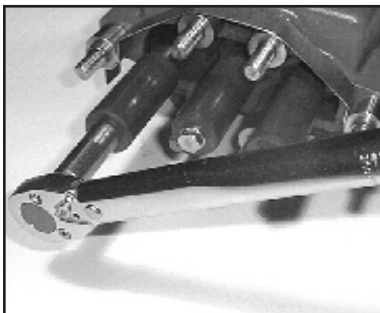

33a. Torque the ceramic plunger bolt assembly to 300 inch-pounds (34 Nm). If originally removed, reinstall the stud bolts (#49).

34. Install the rear support ring (#41), rear v-sleeve (#40), rear pressure ring (#39). Install the snap ring (#36).

35. Reinstall the pressure ring (#39), v-sleeves (#40) and support ring (#41) into each plunger bore. Reinstall the tension spring (#42).



36. Reassemble the discharge valve assembly by placing the valve plate (#45), spring (#46), and spring retainer (#47) on top of the valve seat (#44). Press fit together.

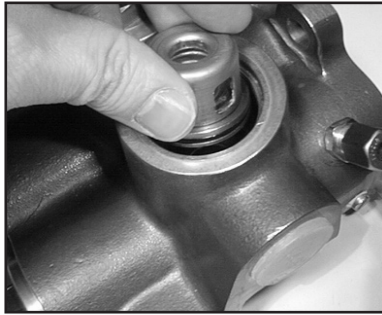

37. Place the entire discharge assembly into discharge port making certain the assembly is properly seated. Install discharge plug (#48) and hand tighten.

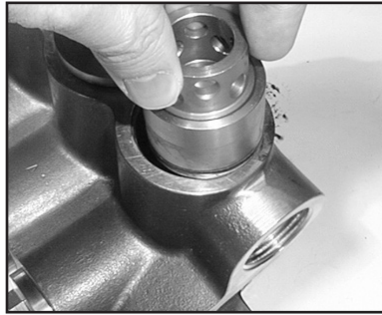

38. Reassemble the inlet valve assembly in the reverse order of step #7. Make certain all the components are press fit together and that the spring retainer (#54) is slightly counter sunk in the valve housing (#52). Grease the o-ring (#53) and install it on to the valve housing. Reinstall the entire inlet valve assembly into the manifold (#43). install the tension plugs (#42A) and tighten.

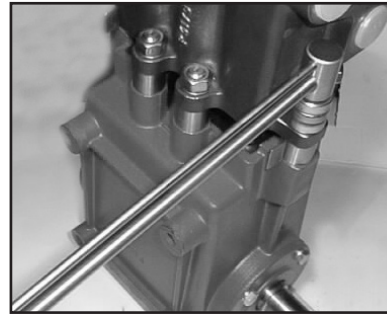

39. Lubricate the plungers (29B) again and slide the manifold (#43) gently and evenly over the plungers. Press the manifold firmly into place against the crankcase (#1). Install the spring washer (#50A) and tighten the manifold stud nuts (#50) to 696 inch-pounds (79 Nm).

MP4130-3100 & MP4135-3100 TORQUE SPECIFICATIONS

<u>Position</u>	<u>Item#</u>	<u>Description</u>	<u>Torque Amount - in.-lbs. (Nm)</u>
17	08095	Hex Screw, Bearing Cover	125 (14)
24A	05349	Hex Screw, Connecting Rod	250 (28)
29C	04150	Bolt, Plunger	300 (34)
50	07158	Nut, Manifold Stud	700 (79)

Pump Mounting Selection Guide

Bushings

01074 24 mm Tapered H Bushing

Pulley & Sheaves

01061 7.75" Cast Iron 1 gr. - AB Section

01062 7.75" Cast Iron - 2 gr. - AB Section

Rails

01160 Plated Steel Channel Rails
(L=5.75"x W=1.00"x h=2.50")

01161 Plated Steel Channel Rails
(L=5.75"x W=1.00"x H=2.50")

PUMP SYSTEM MALFUNCTION

<u>MALFUNCTION</u>	<u>CAUSE</u>	<u>REMEDY</u>
The Pressure and/or the Delivery Drops	Worn packing seals Broken valve spring Belt slippage Worn or Damaged nozzle Fouled discharge valve Fouled inlet strainer Worn or Damaged hose Worn or Plugged relief valve on pump Cavitation Unloader	Replace packing seals Replace spring Tighten or Replace belt Replace nozzle Clean valve assembly Clean strainer Repair/Replace hose Clean, Reset, and Replace worn parts Check suction lines on inlet of pump for restrictions Check for proper operation
Water in crankcase	High humidity Worn seals	Reduce oil change interval Replace seals
Noisy Operation	Worn bearings Cavitation	Replace bearings, Refill crankcase oil with recommended lubricant Check inlet lines for restrictions and/or proper sizing
Rough/Pulsating Operation with Pressure Drop	Worn packing Inlet restriction Accumulator pressure Unloader Cavitation	Replace packing Check system for stoppage, air leaks, correctly sized inlet plumbing to pump Recharge/Replace accumulator Check for proper operation Check inlet lines for restrictions and/or proper size
Pressure Drop at Gun	Restricted discharge plumbing	Re-size discharge plumbing to flow rate of pump
Excessive Leakage	Worn plungers Worn packing/seals Excessive vacuum Cracked plungers Inlet pressure too high	Replace plungers Adjust or Replace packing seals Reduce suction vacuum Replace plungers Reduce inlet pressure
High Crankcase Temperature	Wrong Grade of oil Improper amount of oil in crankcase	Giant oil is recommended Adjust oil level to proper amount

Preventative Maintenance Check-List & Recommended Spare Parts List						
Check	Daily	Weekly	50hrs	Every 500 hrs	Every 1500 hrs	Every 3000 hrs
Oil Level/Quality	X					
Oil Leaks	X					
Water Leaks	X					
Belts, Pulley		X				
Plumbing		X				
Recommended Spare Parts						
Oil Change (1 Quart)			X	X		
Seal Kit (1 kit/pump) (See page 5 for kit list)					X	
Valve Spare Parts (1 kit/pump) (See page 5 for kit list)						X

MP4130-3100 & MP4135-3100 DIMENSIONS - Inches (mm)

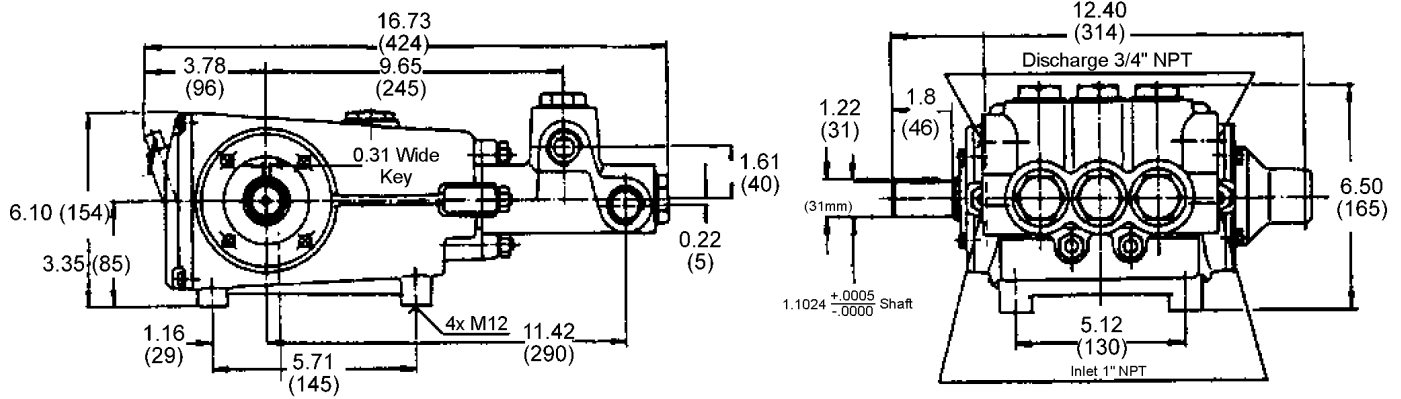

GIANT INDUSTRIES LIMITED WARRANTY

Giant Industries, Inc. pumps and accessories are warranted by the manufacturer to be free from defects in workmanship and material as follows:

1. For portable pressure washers and car wash applications, the discharge manifolds will never fail, period. If they ever fail, we will replace them free of charge. Our other pump parts, used in portable pressure washers and in car wash applications, are warranted for five years from the date of shipment for all pumps used in NON-SALINE, clean water applications.
2. One (1) year from the date of shipment for all other Giant industrial and consumer pumps.
3. Six (6) months from the date of shipment for all rebuilt pumps.
4. Ninety (90) days from the date of shipment for all Giant accessories.

This warranty is limited to repair or replacement of pumps and accessories of which the manufacturer's evaluation shows were defective at the time of shipment by the manufacturer. The following items are NOT covered or will void the warranty:

1. Defects caused by negligence or fault of the buyer or third party.
2. Normal wear and tear to standard wear parts.
3. Use of repair parts other than those manufactured or authorized by Giant.
4. Improper use of the product as a component part.
5. Changes or modifications made by the customer or third party.
6. The operation of pumps and or accessories exceeding the specifications set forth in the Operations Manuals provided by Giant Industries, Inc.

Liability under this warranty is on all non-wear parts and limited to the replacement or repair of those products returned freight prepaid to Giant Industries which are deemed to be defective due to workmanship or failure of material. A Returned Goods Authorization (R.G.A.) number and completed warranty evaluation form is required prior to the return to Giant Industries of all products under warranty consideration. Call (419)-531-4600 or fax (419)-531-6836 to obtain an R.G.A. number.

Repair or replacement of defective products as provided is the sole and exclusive remedy provided hereunder and the MANUFACTURER SHALL NOT BE LIABLE FOR FURTHER LOSS, DAMAGES, OR EXPENSES, INCLUDING INCIDENTAL AND CONSEQUENTIAL DAMAGES DIRECTLY OR INDIRECTLY ARISING FROM THE SALE OR USE OF THIS PRODUCT.

THE LIMITED WARRANTY SET FORTH HEREIN IS IN LIEU OF ALL OTHER WARRANTIES OR REPRESENTATION, EXPRESS OR IMPLIED, INCLUDING WITHOUT LIMITATION ANY WARRANTIES OR MERCHANTABILITY OR FITNESS FOR A PARTICULAR PURPOSE AND ALL SUCH WARRANTIES ARE HEREBY DISCLAIMED AND EXCLUDED BY THE MANUFACTURER.



GIANT INDUSTRIES, INC., 900 N. Westwood Ave., Toledo, Ohio 43607
 PHONE (419) 531-4600, FAX (419) 531-6836, www.giantpumps.com
 © Copyright 2012 Giant Industries, Inc.