

ZBDR - ZBDG

EL/POMPE SOMMERSIBILI

SERIE "ZBDR" con girante multicanale aperta
SERIE "ZBDG" con girante a vortice

SUBMERSIBLE EL/PUMPS

"ZBDR" SERIES with multi-channel impeller
"ZBDG" SERIES with vortex impeller



ZBDR



ZBDG

APPLICAZIONI:

Sollevamento di liquido tipo: liquami, acque cariche contenenti piccoli corpi solidi in sospensione e fanghi greggi.

APPLICATIONS:

Lifting of liquid like: sewage, dirty water with small suspended solid parts and mud.

COSTRUZIONE:

Corpo pompa: BRONZO B10
Girante: BRONZO B10
Albero: ACCIAIO INOX AISI 316
Tenute meccaniche: N.1 GRAFITE ALLUMINA - NBR
..... N.1 CARBURO DI SILICIO INTEGRALE - VITON

CONSTRUCTION FEATURES:

Body pump: BRONZE B10
Impeller: BRONZE B10
Shaft: STAINLESS STEEL AISI 316
Mechanical seals: N.1 GRAPHITE ALUMINA - NBR
..... N.1 INTEGRAL SILICON CARBIDE - VITON

MOTORI:

Isolamento: Classe "F"
Protezioni: "IP 68"
Tensioni: 1~230 V ; 3~230/400 V C.A. 50Hz

MOTORS:

Insulation: "F" class
Protections: "IP 68"
Voltages: 1~230 V ; 3~230/400 V A.C. 50Hz

GENERALITÀ:

L'el/pompa sommergibile serie "ZBDR", con girante aperta multi-canale, è indicata per il sollevamento di liquidi leggermente carichi con piccoli corpi solidi in sospensione e contenenti sostanze schiumose e/o oleose.

L'el/pompa sommergibile serie "ZBDG", con girante arretrata tipo Vortex che garantisce ampi passaggi liberi, trova impiego in presenza di liquidi carichi, con corpi solidi non deformabili in sospensione anche contenenti sostanze schiumose e/o oleose.

Particolarmente adatta per le acque nere.

Durante il funzionamento, per un corretto utilizzo le el/pompe serie "ZBDR - ZBDG" devono sempre essere completamente sommerse nel liquido pompato.

GENERALITY:

Submersible el/pump "ZBDR series", with open multi-channel impeller, is suitable for lightly dirty liquids with small solid suspended parts and containing foamy and/or oily substance.

Submersible el/pump "ZBDG" series, with a Vortex back impeller type which ensure large free flow passages, is suitable for dirty liquids with small crushproof solid suspended parts also containing foamy and/or oily substances.

Highly recommended for black waters.

During their functioning, for a proper use, the "ZBDR - ZBDG" el/pump series must be always completely submersed in the pumped liquid.

GARANZIA:

Due anni (vedi condizioni generali di vendita)

WARRANTY:

Two years (see our general sale conditions)

PRESTAZIONI:

PERFORMANCE:

TIPO TYPE	kW	RPM	Head - Pressione (m)																
			m³/h l/min	0	3	6	9	12	15	18	21	24	27	30	33	36	39	42	45
ZBDR 50	0.37	2900	8.6	8.1	7.3	6.1	4.4	2.2											
ZBDG 50			7.6	6.8	5.9	4.9	3.8	2.9	2										
ZBDR 100	0.90	2900	12.2	11.9	11.5	11	10.4	9.7	8.9	7.9	6.9	5.7	4.3	2.8					
ZBDG 100			12.2	11.5	10.6	9.5	8.8	7.8	6.6	5.5	4.3	3.4							
ZBDR 150	1.20	2900	15.9	15.6	15.1	14.6	14	13.4	12.7	11.8	10.9	9.9	8.7	7.4	6	4.4			
ZBDG 150			14	13.2	12.3	11.3	10.4	9.4	8.3	7.5	6.3	5.2	4.1	3					
ZBDR 200	1.50	2900	18	17.5	16.9	16.4	15.8	15.2	14.6	13.8	12.9	11.9	10.8	9.6	8.3	6.9	5.5	3.9	
ZBDG 200			15	14.2	13.2	12.3	11.3	10.3	9.2	8.2	7.1	6	5	3.9	2.9				

DIMENSIONI E PESI:

DIMENSION AND WEIGHT:

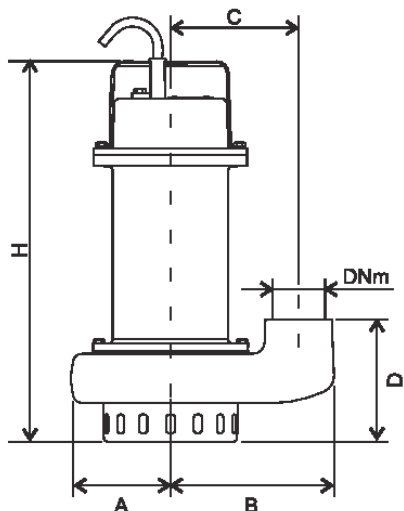

TIPO TYPE	A	B	C	D	H	DNm	Peso Weight
ZBDR 50	77	132	103	110	340	1" 1/4	17
ZBDR 100	96	166	130	124	390	2"	21
ZBDR 150	96	166	130	124	390	2"	23
ZBDR 200	96	166	130	124	390	2"	25

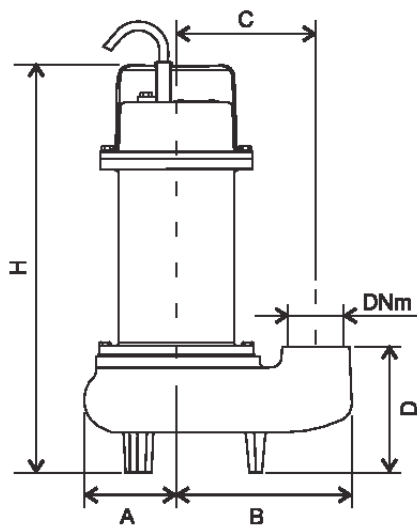

TIPO TYPE	A	B	C	D	H	DNm	Peso Weight
ZBDG 50	77	149	110	119	360	2"	18
ZBDG 100	80	166	127	132	412	2"	22
ZBDG 150	80	166	127	132	412	2"	23
ZBDG 200	80	166	127	132	412	2"	25

Nota: Le dimensioni sono indicative. Misure in mm – Pesi in Kg