

ACB 331 - 332 - 431 - 531 - 631

50Hz

EL/POMPE AUTOADESCANTI
SERIE "ACB 331 - 332 - 431 - 531 - 631"
Ad anello liquido

SELF-PRIMING EL/ PUMPS
"ACB 331 - 332 - 431 - 531 - 631" SERIES
Liquid ring



ACB 331 (C.A. - A.C.)



ACB 531 (C.A. - A.C.)

APPLICAZIONI:

Esaurimento sentina, antincendio, lavaggio catene, travaso gasolio, alimentazione impianti, movimentazione liquidi ad alto contenuto d'aria, ecc.

APPLICATIONS:

Bilge, fire-fighting, chain washing, intake diesel oil, plants water supply, mixtures with high air content liquids handling, etc

COSTRUZIONE:

Corpo pompa: BRONZO
Girante: BRONZO
Albero: ACCIAIO INOX AISI 316
Tenuta meccanica: DI ALTA QUALITÀ IN CERAMICA,
..... GRAFITE INOX

CONSTRUCTION FEATURES:

Body pump: BRONZE
Impeller: BRONZE
Shaft: STAINLESS STEEL AISI 316
Mechanical seal: HIGH QUALITY ON CERAMIC,
..... GRAPHITE INOX

MOTORI:

Isolamento: Classe "F"
Protezioni: "IP 55"
Tensioni: 230V 1~ 50Hz
..... Δ220÷240/Y380÷415V, Δ380÷415V 3~ 50Hz

MOTORS:

Insulation: "F" class
Protections: "IP 55"
Voltages: 230V 1~ 50Hz
..... Δ220÷240V Y380÷415V, Δ380÷415V 3~ 50Hz

GENERALITÀ:

Le elettropompe pompe auto-adescenti ad anello liquido serie "ACB", con girante stellare, hanno una eccezionale capacità di auto-innesco (fino a 8m verticale).

Solo al primo avviamento o dopo un lungo periodo di inutilizzo, si rende necessario il riempimento del corpo pompa, in seguito, anche con il tubo di aspirazione vuoto, adescano automaticamente.

Si consiglia di installare sulla bocca di aspirazione un filtro ed una valvola a clapet per evitare il reflusso d'acqua.

GENERALITY:

The liquid ring self-priming electro-pump "ACB" series, with star impeller, have an outstanding self-priming capacity (up to 8m vertical).

Only at the first start or after a long term disuse, it is necessary to fill the pump's body with water, then, the pump automatically primes, also with the suction pipe empty.

We suggest to install a filter and a clapet valve on the suction pipe in order to avoid a water reflux.

GARANZIA:

Due anni (vedi condizioni generali di vendita)

WARRANTY:

Two years (see our general sale conditions)

PRESTAZIONI (50Hz):

PERFORMANCE (50Hz):

EL/POMPA EL/PUMP	POTENZA INST. INST. POWER	MOTORI DISPONIBILI AVAILABLE MOTORS	GIRI/1' RPM	PORTATA l/min								DELIVERY l/min																			
				40	50	60	70	80	90	100	110	120	130	140	150	180	210														
				PORTATA m ³ /h								DELIVERY m ³ /h																			
				2.4	3.0	3.6	4.2	4.8	5.4	6.0	6.6	7.2	7.8	8.4	9.0	10.8	12.6														
				PREVALENZA TOTALE m H ₂ O								TOTAL MANOMETRIC HEAD m H ₂ O																			
				H kW	H kW	H kW	H kW	H kW	H kW	H kW	H kW	H kW	H kW	H kW	H kW	H kW	H kW														
ACB 331/B	1.5	1~ 3~	1450	36	1.4	33	1.4	30	1.3	27	1.3	23	1.2	19	1.2	16	1.1	12	1.1	9	1.0	6	1.0	3	0.9						
ACB 332/B	2.2	1~ 3~	1450			55	2.1	49	2.0	44	1.9	39	1.8	33	1.7	27	1.6	22	1.6	16	1.5	11	1.5	5	1.5						
ACB 431/C	3.0	1~ 3~	1450			46	2.9	44	2.8	42	2.7	40	2.5	37	2.3	35	2.2	32	2.0	29	1.8	27	1.8	24	1.7	22	1.7	14	1.6	6	1.6
ACB 431/B	2.2	1~ 3~	1450											35	2.2	32	2.0	29	1.8	27	1.8	24	1.7	22	1.7	14	1.6	6	1.6		

Note: I dati indicati sono relativi alle versioni trifase (3~). Legenda: (kW) Potenza assorbita
Considerare una riduzione del 10% nella prevalenza per le versioni monofase (1~) Prestazioni secondo EN ISO 9906
Notes: Reported data are relative to three-phases versions (3~). Legend: (kW) Absorbed power
Apply a 10% reduction to obtain the head performances for the single-phase versions (1~) Performance in accordance with EN ISO 9906

DIMENSIONI E PESI:

DIMENSIONS AND WEIGHTS:

EL/POMPA - EL/PUMP	f	h	h'	i	a	b	m	n	c	DNa	DNm	Kg
ACB 331/ B	465	225*	200	175	30	110	125	140	250	1"1/4	1"1/4	30
ACB 332/ B	530	240*	213	193	30	145	140	160	300	1"1/4	1"1/4	38
ACB 431/ B - C	525	260*	230	200	32	125	140	160	280	1"1/2	1"1/2	45 - 47

EL/POMPA - EL/PUMP	f	h'	i	a	b	m	n	c	l	g	DNa	DNm	Kg
ACB 331F/ B	475	270	175	40	110	125	140	260	75	11	1"1/4	1"1/4	32
ACB 332F/ B	540	280	190	40	145	140	160	310	75	11	1"1/4	1"1/4	40
ACB 431F/ B - C	535	300	200	42	125	140	160	290	90	11	1"1/2	1"1/2	47 - 49

Nota: Le dimensioni sono indicative. Misure in mm - Notes: Dimensions are approximated. Dimensions in mm
*Nelle versioni monofase considerare un incremento di 30-40 mm (h) - *For single-phase versions consider an increase of 30-40 mm (h)

**EL/POMPE CON BOCHE
FILETTATE**
**EL/PUMPS WITH
THREADED CONNECTIONS**

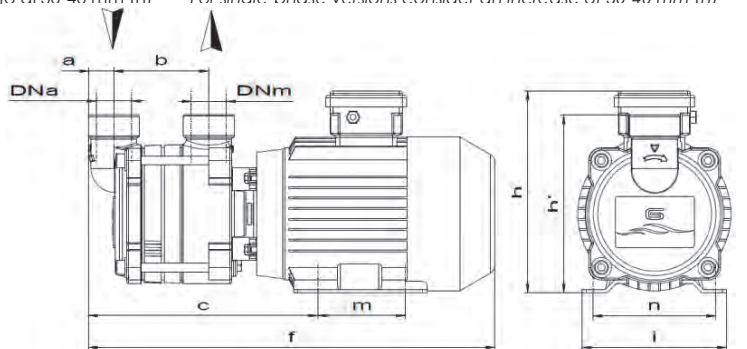

**EL/POMPE CON BOCHE
FLANGIATE**
**EL/PUMPS WITH FLANGED
CONNECTIONS**

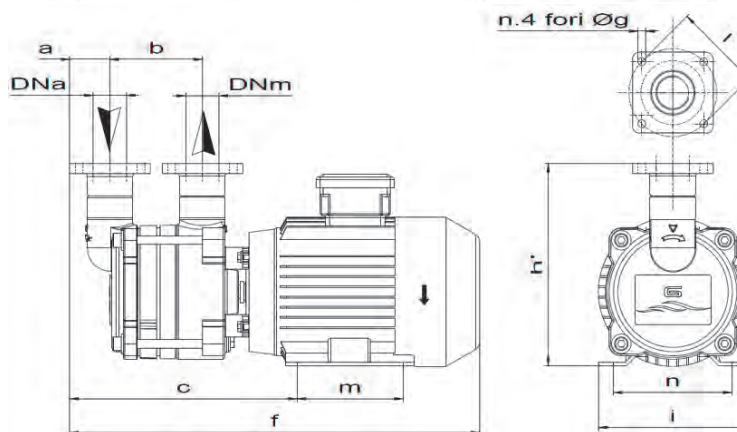

PRESTAZIONI (50Hz):

PERFORMANCE (50Hz):

EL/POMPA EL/PUMP	POTENZA INST. INST. POWER	MOTORI DISPONIBILI AVAILABLE MOTORS	GIRI/1' RPM	PORTATA l/min						DELIVERY l/min					
				100	140	180	200	250	300	350	400	450	500		
				PORTATA m ³ /h						DELIVERY m ³ /h					
				6	8.4	10.8	12	15	18	21	24	27	30		
				PREVALENZA TOTALE m H ₂ O						TOTAL MANOMETRIC HEAD m H ₂ O					
				H kW	H kW	H kW	H kW	H kW	H kW	H kW	H kW	H kW	H kW		
ACB 531/A	4	1~ 3~	1450			33 3.9	32 3.8	29* 3.7	25 3.5	20 3.2	14 2.9	8 2.6	3 2.2		
ACB 531/B	5.5	3~	1450	35 4.2	34 4.0	33 3.9	32 3.8	29 3.7	25 3.5	20 3.2	14 2.9	8 2.6	3 2.2		

EL/POMPA EL/PUMP	POTENZA INST. INST. POWER	MOTORI DISPONIBILI AVAILABLE MOTORS	GIRI/1' RPM	PORTATA l/min						DELIVERY l/min					
				300	350	400	450	500	550	600	650	700	750		
				PORTATA m ³ /h						DELIVERY m ³ /h					
				18	21	24	27	30	33	36	39	42	45		
				PREVALENZA TOTALE m H ₂ O						TOTAL MANOMETRIC HEAD m H ₂ O					
				H kW	H kW	H kW	H kW	H kW	H kW	H kW	H kW	H kW	H kW		
ACB 631/A	7,5	3~	1450					32 7	27 6.3	22 5.7	17 5.1	12 4.5	6 4		
ACB 631/B	9,2	3~	1450	49 9.0	45 8.5	42 8	37 7.5	32 7	27 6.3	22 5.7	17 5.1	12 4.5	6 4		

Note: I dati indicati sono relativi alle versioni trifase (3~). Prestazioni secondo EN ISO 9906. Legenda: (kW) Potenza assorbita

*Prevalenza massima con motore 1~

Notes: Reported data are relative to three-phases versions (3~). Performance in accordance with EN ISO 9906. Legend: (kW) Absorbed power

*Max manometric head with 1~ motor

DIMENSIONI E PESI:

DIMENSION AND WEIGHT:

EL/POMPA - EL/PUMP	f	h	a	b	c	e	m	o	n	i	s	l	g	DNa	DNm	Kg
ACB 531/A	570	295	110	140	20	-	480	520	195	235	30	110	13	2"	2"	63
ACB 531/B	640	300	110	140	35	190	140	240	215	255	30	110	13	2"	2"	75
ACB 631/A	600	350	130	160	-	-	178	220	216	260	35	130	13	2" 1/2	2" 1/2	95
ACB 631/B	620	350	130	160	-	-	178	220	216	260	35	130	13	2" 1/2	2" 1/2	110

Nota: Le dimensioni sono indicative. Misure in mm - Notes: Dimensions are approximated. Dimensions in mm

EL/POMPE CON BOCCHIE FLANGIATE - EL/PUMPS WITH FLANGED CONNECTIONS

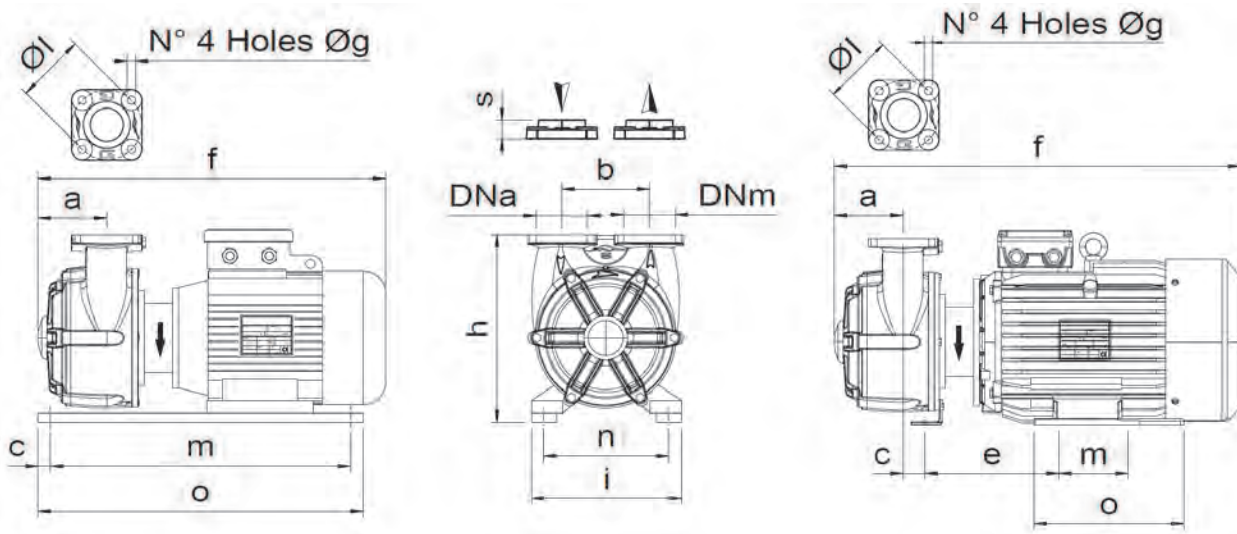

ACB 531/A

ACB 531/B - ACB 631/A - ACB 631/B

