



INNOVATIVE PUMP
AND FILTER TECHNOLOGY



VERTICAL CENTRIFUGAL IMMERSION PUMPS

60 W – 15 KW (0.1 – 20 HP)

FOR AGGRESSIVE AND NEUTRAL LIQUIDS

TURN OUR EXPERIENCE INTO YOUR SUCCESS

For over 25 years, our work has made processes involving liquid media both more reliable and more economical.

Thanks to many years' work in this specialist field on the part of company founder Wolfgang Renner, comprehensive expert knowledge was available right from the outset, and over time this developed into true international know-how. Today, many new ideas, a well-developed quality awareness and the use of innovative technologies create the conditions for a flexible, customer-orientated product range that optimally meets the demands of modern, industrial process sequences. Wherever there is a need for innovation and special quality, experts today rely on pumps, filters and the associated fittings and apparatus from Renner.



An excellent price/performance ratio thanks to efficient production of the components

our experience gained in similar work. And it goes without saying that at the same time, our approach involves incorporating pumps and filters into the system as a whole. A comprehensive range of components that can be



Even unusual ideas can be realised quickly by modern design methods

We are our customers' competent partner for all applications involving excellent, complete system solutions.

The Renner philosophy and the Renner design principle ensure results that are individually orientated towards your aims. This ensures that you profit fully from our expert knowledge and from



State-of-the-art plastic injection moulding production

combined in an unequalled variety of ways ensures that products that meet your requirements exactly are in fact created when it comes to actual realisation. And for special cases in which even this is not enough, our designers are more than happy to pursue new and creative paths with you.



Modern plastic machining on computer-controlled machining centres

We regard research and development as an investment in the future.

Existing products are continuously being improved and new possibilities designed and realised in close collaboration with our customers, universities and the engineers of our technical department. The decisive yardstick here is always the practical benefits to the user.



The company's own technical centre is constantly working to find even better solutions



The modules are called forward from the central storage system on an order-specific basis



Content	Page
The company	2 - 4
Technical information	5 - 10
Special versions of the RT series	11
Series RT 1 HQmax 7 mWC / 32 l/min	12/13
Series RT 1.5 HQmax 10 mWC / 85 l/min	14/15
Series RT 2 HQmax 12 mWC / 130 l/min	16/17
Series RT 3 HQmax 25 mWC / 280 l/min	18/19
Series RT 4 HQmax 32 mWC / 600 l/min	20/21
Series RT 5 HQmax 42 mWC / 1000 l/min	22/23
Series RT 6 HQmax 43 mWC / 1700 l/min	24/25
RT filter combinations	26 - 28
Working assistants/ Pressure loss calculation	29/30
Questionnaire	31

Q = \dot{V} = Delivery rate (Flow rate)
H = Delivery height in mWC



The service life of a pump depends greatly on the precision of the shaft



Manual work is required in the final assembly stage, with experienced staff assembling components to make high-precision units

Our great depth of production gives both you and us a good conscience.

Many of our competitors' production plants regard outsourcing as a good idea. Not us. Right from the beginning, our aim has always been to manufacture all the most important components of our products ourselves.

Experience has shown that only in this way is it possible to meet all the quality criteria to completely fulfil our customers' quality demands. And only in this way do we do justice to our own concept of quality. This approach and way of working have also ensured that innovative ideas and further developments have arisen time and again, and these have in turn made a significant contribution towards giving us a technological edge in both design and production. And that's not to mention the advantages in consultation and service that are only possible to this extent if a company is truly familiar with its products down to the smallest detail.



All components are tested with highly-accurate measuring instruments prior to installation

You'll be impressed by our company philosophy.

Everything that we do is aimed at durability and sustainability, and focuses on the interests of our customers. That's why we're always looking for an even better solution, use resources sparingly and attach great value to dealing with our customers and suppliers openly and honestly. You'll notice this special atmosphere right from the very first discussion that you have with us.

The quality of our products is excellent.

Renner pumps and filters have always been known for their excellent quality. It goes without saying that our company and the entire production sequences are certified – and in many areas we even exceed these requirements because of the demands that we place on ourselves. In addition to this, all products undergo a 100 % inspection before leaving the factory.



INNOVATIVE TECHNOLOGY MAKES THE DIFFERENCE



In this area of use too, the search for even better and more perfect solutions has given rise to an unsurpassed technical standard from which our customers profit.

Renner vertical centrifugal immersion pumps boast robust, practical construction and design. Thanks to the use of a variety of materials, the components in contact with the medium are insensitive to both corrosion and chemicals. Other design-related advantages are safety in the event of running dry (without intermediate bearings), the low space requirement and individual conformity to customer-specific installation flange dimensions.

Renner vertical centrifugal immersion pumps are designed for vertical use in non-pressurised tanks, open containers or pits.

They have proved to be extremely successful in transporting and circulating pure, slightly contaminated or abrasive media, aqueous solutions, suspensions or liquid mixtures.

The most important pumped media:

Acids, caustic solutions, mixtures, solvents, alkaline degreasing baths, electrolytic baths, photo chemicals, radioactive, sterile or particularly valuable liquids, foodstuffs and many other low-viscosity media.

Viscosity

Liquids up to approx. 160 mPas (160 cP)

The advantages of the Renner technology are particularly appreciated in applications with exacting quality demands.

Consequently, Renner vertical centrifugal immersion pumps are successfully used in both mechanical and systems engineering as well as in the chemicals and pharmaceuticals industry, environmental and process engineering, water and waste water treatment and in the textiles and foodstuffs industry. But that's not all. Experts also rely on Renner Series RT pumps for fitting out etching and cleaning systems, refrigeration machines, solar systems and in the photographic and electroplating industries.

Key data of Series RT1 to RT6

Delivery rate [mm / US GPM]	up to 1700 / 449
Delivery height [mWC / ft.]	up to 43 / 141'
Motor power [kW / HP]	0.060 to 15 / 0.1 to 20
Immersion depths, Series RT, RT-MS and RT-A [mm / inch]	200 to 500 / 7.87" to 19.7"
Immersion depths, Series RT-Z and RT-M [mm / inch]	200 to 2.500 / 7.87" to 98.4"
Materials	PP, PVDF, CPVC, PFA, ECTFE, stainless steel, titanium
Seals	FKM, EPDM, Kalrez, FEP-covered
Operating temperature [°C / °F]	up to 100 / 212

Materials and temperature ranges

For each pumping medium, we offer the necessary material combination in relation to the temperature.

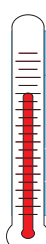

	°C	°F
Stainless steel, titanium, PEEK, PPS (Ryton®), PFA, ECTFE, Oxide ceramic	100	212
PVDF	95	203
PP, CPVC	80	176

Characteristics field overview, Series RT, RT-A, RT-Z and RT-M

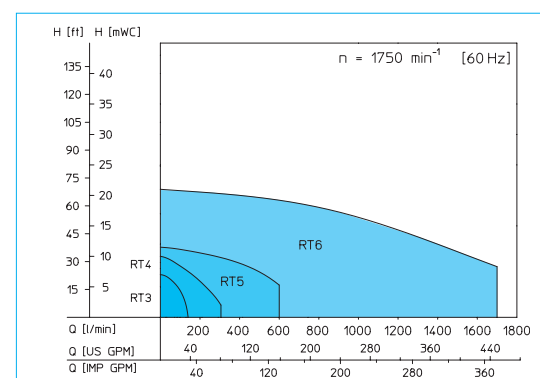
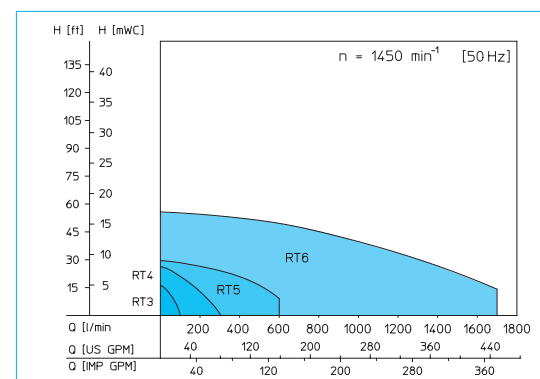
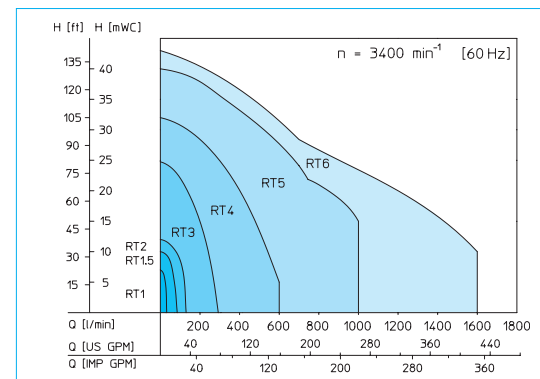
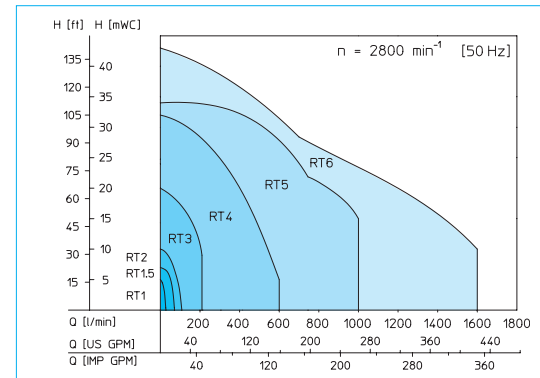

You profit from these design features during your work

Protection type

IP55
(fan cover with protective roof,
explosion protection on request)

Sound pressure level

Low-vibration running
The sound pressure level is < 70 dB (A)
in accordance with DIN EN 12639
(noise measurement, liquid pumps)

Electrical drive

TEFC, single-phase
or three-phase low-voltage
motors with squirrel-cage rotor.
Available on request with integrated
frequency converter

Paint finish

Dual-component protective paint finish.
Special colours always possible

Shaft lead-through seal combinations

Various seals are used,
depending on the application.
Renner offers a patented sealing
system specially for heavily
crystallising media

Corrosion-free

Plastic pump without metal parts
in contact with the medium.
The motor shaft is completely encased in plastic

Performance data

The right impeller
for any delivery rate
(see characteristic fields)

Multi-stage version RT-MS on request.

Pressure connection

Threaded connector conforming to DIN 8063
Optional flange connection conforming to
DIN 2501 PN10/16



Fixed connection
angled 90°



Fixed connection
vertically upwards

A filter can be fitted instead of
the pressure pipe



Pressure pipe



Filter

Flange dimensions

Customer-specific
dimensions always
possible at short notice!

Robust construction

Welded connection:
The pump housing, installation flange,
riser pipe and pressure pipe
form a complete unit.
Also available as a flexible
screw connection

Efficiency

More efficient thanks
to a spiral housing

Suction connection

Suction side: includes suction screen to
protect the pump against coarse impurities.
Optionally also available with an extension pipe

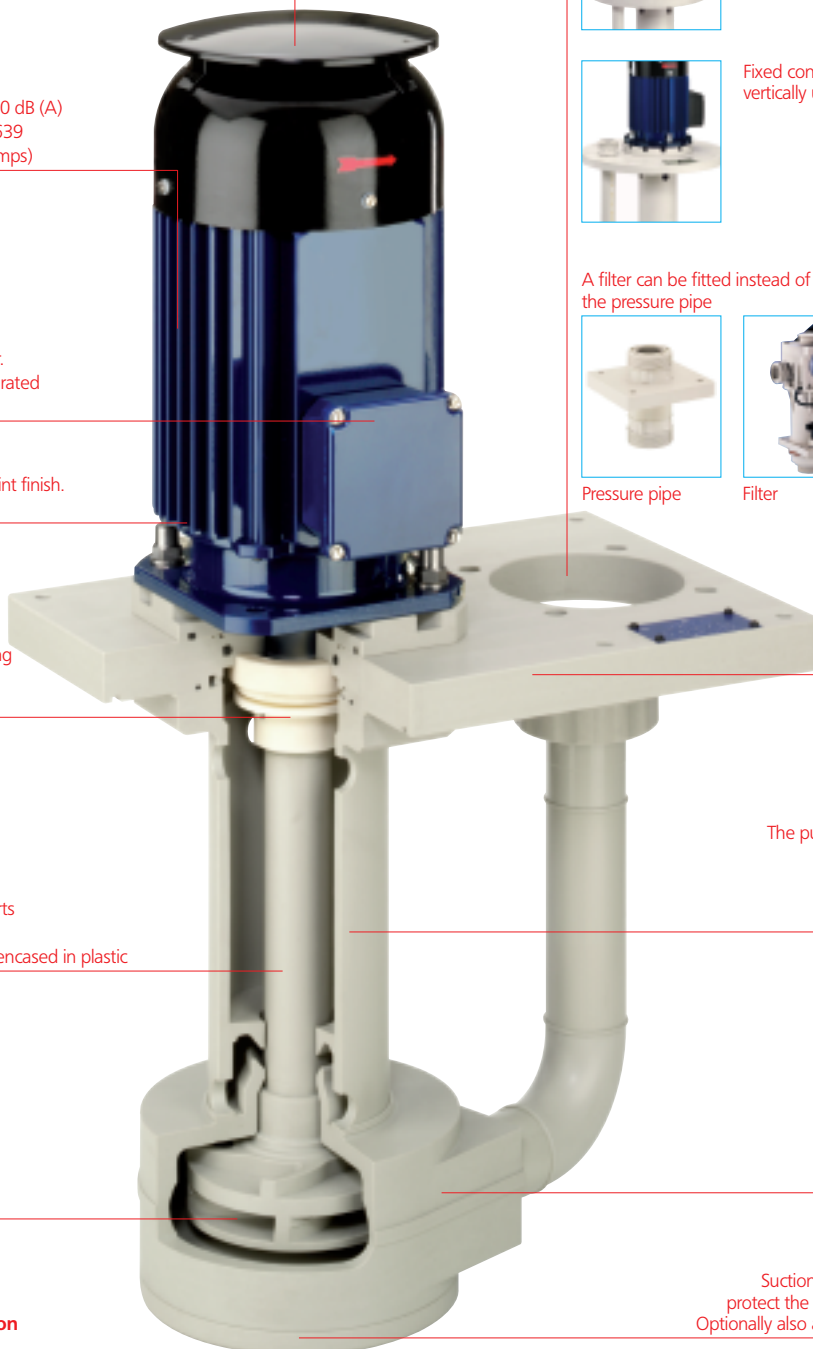

Select from a variety of drives

Three-phase motors	60 W to 15 kW
AC motors	60 W to 1.5 kW
Design	IM B5 or IM B14
Voltage	See "International mains voltages and frequencies"
Speed	1450//1750 rpm, 50//60 Hz 2800//3400 rpm, 50//60 Hz
Protection type	IP55 (other protection types on request)
Protective roof	integrated



Precision and know-how
give the customer security



Low noise level
thanks to low-
vibration running

If required, Series RT vertical centrifugal immersion pumps can also be fitted with an integrated variable-speed drive.

In all Renner centrifugal pumps, the pump, motor and frequency converter form one compact unit. This allows small dimensions, increases operational readiness and reduces costs.



The frequency converters are available in various versions.

Control is optionally possible via: Terminal strip, analog input, serial interface, potentiometer, control panel, field bus (Profibus, etc.)

What you should know about variable-speed drive and frequency converters.

Thanks to advances in performance electronics, high-performance frequency converter units are now available for controlling and regulating the speed of three-phase asynchronous motors. These variable-speed drives permit a centrifugal pump to be adjusted to suit the particular requirements of an individual application, and enable power consumption to be reduced. This enables every desired operating point to be reached, right up to the load limit of the

pump or motor. Low energy consumption and a lack of superfluous control valves save costs, with the result that the high purchase price of a variable-speed centrifugal pump is recovered within a very short time.

Centrifugal pumps are designated as an application with square torque. This means that the speed and capacity ratio is cubic. If the speed is reduced, the load is reduced much more. For example, if the speed is reduced by 50 %, only 12 % of the capacity is still required!

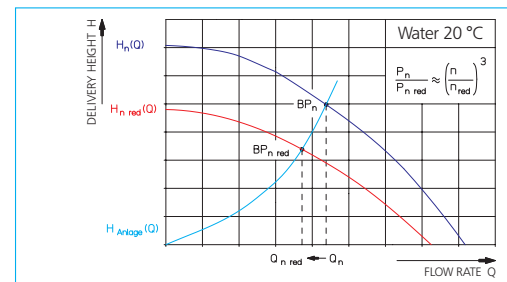

If the frequency converter is integrated in the terminal box, the EMC regulations have been fulfilled and there is no need for the adjustment of an external converter. The unit consisting of the frequency converter, three-phase motor and centrifugal pump is delivered ready to connect and pre-programmed. In all, far less space is required for new installations. In the case of modernisations, it is possible to make use of all the advantages of a frequency converter in the existing process.

Thanks to the variety of possible external control signals for speed adjustment, this compact system can be directly incorporated into the plant's higher-order control systems. The converter electronics allow soft start-up and soft run-out of the centrifugal pump via programmable ramp run times. By defining maximum and minimum output

frequencies on the motor side and by masking out any resonance frequencies that arise, it is possible to optimally adjust the centrifugal pump to the respective application.

The advantages of the variable-speed drive integrated in the motor:

- Energy saving
- Fluid control to suit your requirements
- Space-saving drive
- No power loss in the switch cabinet by the FC
- Less installation work
- The pump is delivered ready to connect and pre-programmed
- No long, cost-intensive, shielded motor cables
- No separate EMC filter
- Gentle pumping of the medium
- No heating-up of the pumped medium by energy dissipation
- No external motor circuit breakers thanks to integrated motor protection functions

International mains voltages and frequencies

West Europe	East Europe	Middle East	Far East	North America	Central America	South America	Africa
50 Hz	50 Hz	50 Hz	50 Hz			50 Hz	50 Hz
230 / 400 V	230 / 400 V	220 / 380 V	230 / 400 V			220 / 380 V	220 / 380 V
500 V	690 V	230 / 400 V	220 / 380 V				127 / 220 V
690 V		240 / 415 V	200 / 346 V				240 / 415 V
			240 / 415 V				
			100 / 200 V				
			60 Hz	60 Hz	60 Hz	60 Hz	
			220 / 380 V	120 / 240 V	115 / 200 V	220 / 380 V	
			254 / 440 V	265 / 460 V	220 / 380 V	277 / 480 V	
			110 / 120 V	277 / 480 V	254 / 440 V	115 / 200 V	
				575 V			
				600 V			

Installation instructions

In order to guarantee safe operation of vertical centrifugal immersion pumps, the following instructions must be followed during the planning and installation phases:

- A Thread length, suction side (for screwing on an extension pipe)
- L Immersion depth
- VL Extension pipe, suction side (max. 500 mm)
- X Minimum distance between the suction connector and the tank bottom
- Y Lowest permissible liquid level during any pump start-up.
If a tank is emptied, it must be refilled to above the minimum liquid level before being started up again. While the pump is in operation, the liquid level can be reduced until the screwed-on extension pipe is still below the level, without the pumping flow being interrupted.
- Z Highest permissible filling level

RT – Vertical centrifugal immersion pump

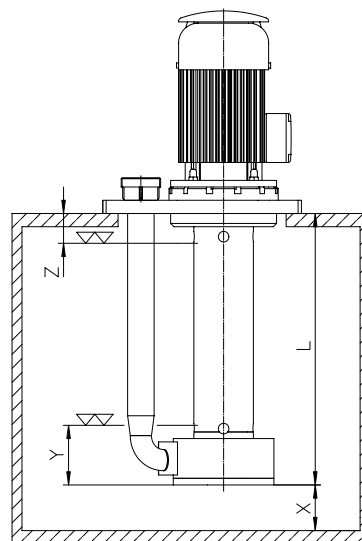

RT – Vertical centrifugal immersion pump with screwed-on extension pipe on the suction side

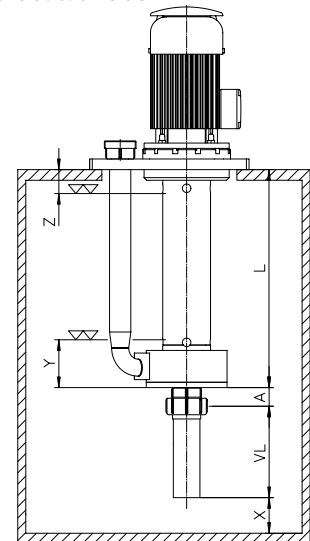

Type key

The type names of the pumps are comprised of several characters that refer to the materials and properties of the individual components. Here is an example:

RT	-	L	-	PP	-	30/340	-	4 / 3	-	300	K	V	Fl. 200 x 300	G 2 1/4"
-		1		2		3		4 5		6	7	8	9	10

No.	Unit part	Code	Material	Pump type RT 1 to 6						
				1	1.5	2	3	4	5	6
1		L	Pump ventilated	●	●	●	●	●	●	●
		M	With magnetic coupling	x	x	●	●	●	x	x
		Z	With intermediate bearing	x	x	x	●	●	●	●
		MS	Multi-stage pump	●	●	●	●	●	●	●
2	PESD unit, Impeller with shaft protection tube	PP	Polypropylene	●	●	●	●	●	●	●
		PVDF	PVDF	●	●	●	●	●	●	●
		CPVC, PVC	CPVC, PVC	x	x	x	x	x	x	x
		PFA	PFA	x	x	x	x	x	x	x
		Ti	Titanium	x	x	x	●	●	x	x
VA	Stainless steel	x	x	●	●	●	x	x		
3	Pump size	.. / ..	See performance curves							
4	Motor power	...								
5	Motor	1	for 1~, 230 VAC	●	●	●	x	x	-	-
		3	for 3~, 400 VAC	x	x	●	●	●	●	●
6	Immersion depth	...	RT: 200 to 500 mm	●	●	●	●	●	●	x
		...	RT-Z: 200 to 2500 mm	x	x	x	●	●	●	●
		...	RT-M: 200 to 2500 mm	x	x	●	●	●	x	x
7	Sealing	K or Ti	Labyrinth	x	x	x	●	●	●	●
		V	V-ring	●	●	●	●	●	●	●
8	O-ring material	V	FKM	●	●	●	●	●	●	●
		E	EPDM	●	●	●	●	●	●	●
		P	NBR	x	x	x	x	x	x	x
		T	FKM FEP-covered	x	x	x	x	x	x	x
9	Installation flange	Dimensions [mm]							
10	Discharge connection	G	Withworth pipe thread	●	●	●	●	●	●	●
		F	Flange	x	x	x	x	x	x	x
		A	ANSI Flange	x	x	x	x	x	x	x
		N	NPT thread	x	x	x	x	x	x	x
		S	Hose connection	x	x	x	x	x	x	x
		RT-SF	For filter attachment	●	●	●	●	●	●	x

● = Preferred programme x = on request - = not available

AN OVERVIEW OF THE MOST IMPORTANT SELECTION CRITERIA

Series	RT	Special version series RT-A	RT-M	RT-Z	RT-MS
Version	Centr. immersion pump for wet installation	Centr. immersion pump for dry installation	Centr. immersion pump with magnetic coupling	Centr. immersion pump with intermediate bearing	Centr. immersion pump multi-stage version
	Safe to run dry	Safe to run dry	Medium-lubricated sliding bearings	Medium-lubricated sliding bearings	Safe to run dry
No. stages	1	1	1	1	2 ... n
Immersion depth 200 to 500 mm / 7.87" to 19.7"	●	●	●	●	●
Immersion depth 200 to 2500 mm / 7.87" to 98.4"	-	-	●	●	On request
Filter attachment possible RT-SF and RT-FI	●	●	●	●	●
Extension pipe (optional) 200 to 500 mm / 7.87" to 19.7"	●	●	●	●	●
Series RT 1	●	●	-	-	●
Series RT 1.5	●	●	-	-	●
Series RT 2	●	●	●	●	●
Series RT 3	●	●	●	●	●
Series RT 4	●	●	●	●	●
Series RT 5	●	●	●	●	●
Series RT 6	●	-	-	●	●
Delivery head up to [mWC / ft.]	43 / 141'	43 / 141'	43 / 141'	43 / 141'	75 / 246'
Flow rate up to [l/min / US GPM]	1700 / 449	1000 / 264	1000 / 264	1700 / 449	1000 / 264
Motor power up to [kW / HP]	15 / 20	7.5 / 10	7.5 / 10	15 / 20	15 / 20
Integrated frequency converter available	●	●	●	●	●



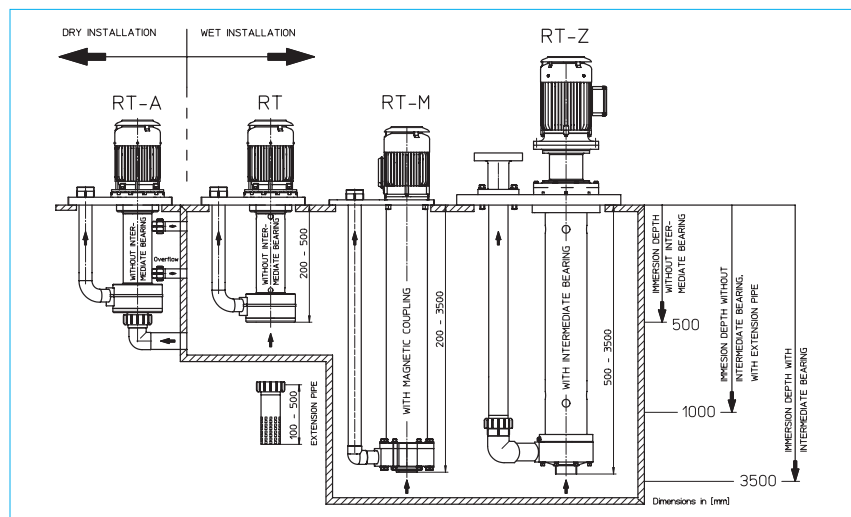

Installation examples

Here you will find in the Renner product range the right pump for every medium, every tank depth and every customer-specific plant design.



SPECIAL VERSIONS OF THE RT SERIES

The technical data and performance curves of Series RT1 to RT6 still apply without changes.

Series	RT-A	RT-M	RT-Z	RT-MS
Version	Vertical centrifugal immersion pump RT1 to RT6 for dry installation outside the tank	Vertical centrifugal immersion pump RT2 to RT6 with magnetic coupling	Vertical centrifugal immersion pump RT2 to RT6 with intermediate bearing	Multi-stage vertical centrifugal immersion pump
Immersion depth [mm / inch]	200 to 500 / 7.87" to 19.7"	200 to 2500 / 7.87" to 98.4"	200 to 2500 / 7.87" to 98.4"	200 to 500 / 7.87" to 19.7"
				
Function method	Attachment of the vertical centrifugal immersion pump outside the tank; connection and piping through the tank wall.	The rear casing hermetically seals off the pump chamber from the drive section. The outer rotating drive magnet transmits the torque to the inner magnet and thereby to the connected impeller.	Immersion depths of up to 2500 mm are possible with an additional liquid-lubricated pump shaft intermediate bearing.	Connecting several impellers in series increased the delivery head. The increase in the pumping pressure (delivery head) is proportional to the number of impellers with the same delivery rate.
Applications	<ul style="list-style-type: none"> • If there is a lack of space in the tank • Same applications as the RT series 	<ul style="list-style-type: none"> • Pumping of outgassing media or media that crystallise heavily when in contact with the atmosphere • Processes incompatible with oxygen • Same applications as the RT series 	<ul style="list-style-type: none"> • Applications with extremely deep tanks or a greatly fluctuating liquid level • Same applications as the RT series 	<ul style="list-style-type: none"> • Processes with high pressures at low delivery rates • When there is a lack of space in the tank (a corresponding single-stage version has a much larger diameter) • Same applications as the RT series
Advantages	<ul style="list-style-type: none"> • Robust design • Safe to run dry • Corrosion-free (parts in contact with the media are made of plastic) • No space requirement inside the tank • Customer-specific installation flange dimensions 	<ul style="list-style-type: none"> • Hermetically tight • No air enters the medium • Robust design • Corrosion-free (parts in contact with the media are made of plastic) • Takes up little space • Customer-specific installation flange dimensions 	<ul style="list-style-type: none"> • The right installation lengths for every application • Robust design • Corrosion-free (parts in contact with the media are made of plastic) • Customer-specific installation flange dimensions 	<ul style="list-style-type: none"> • Small, compact element design • Smaller series with the same pressure • Robust design • Corrosion-free (parts in contact with the media are made of plastic) • Takes up little space • Customer-specific installation flange dimensions

VERTICAL CENTRIFUGAL IMMERSION PUMP

Series RT1

safe to run dry without shaft
intermediate bearing up to an
immersion depth of 400 mm

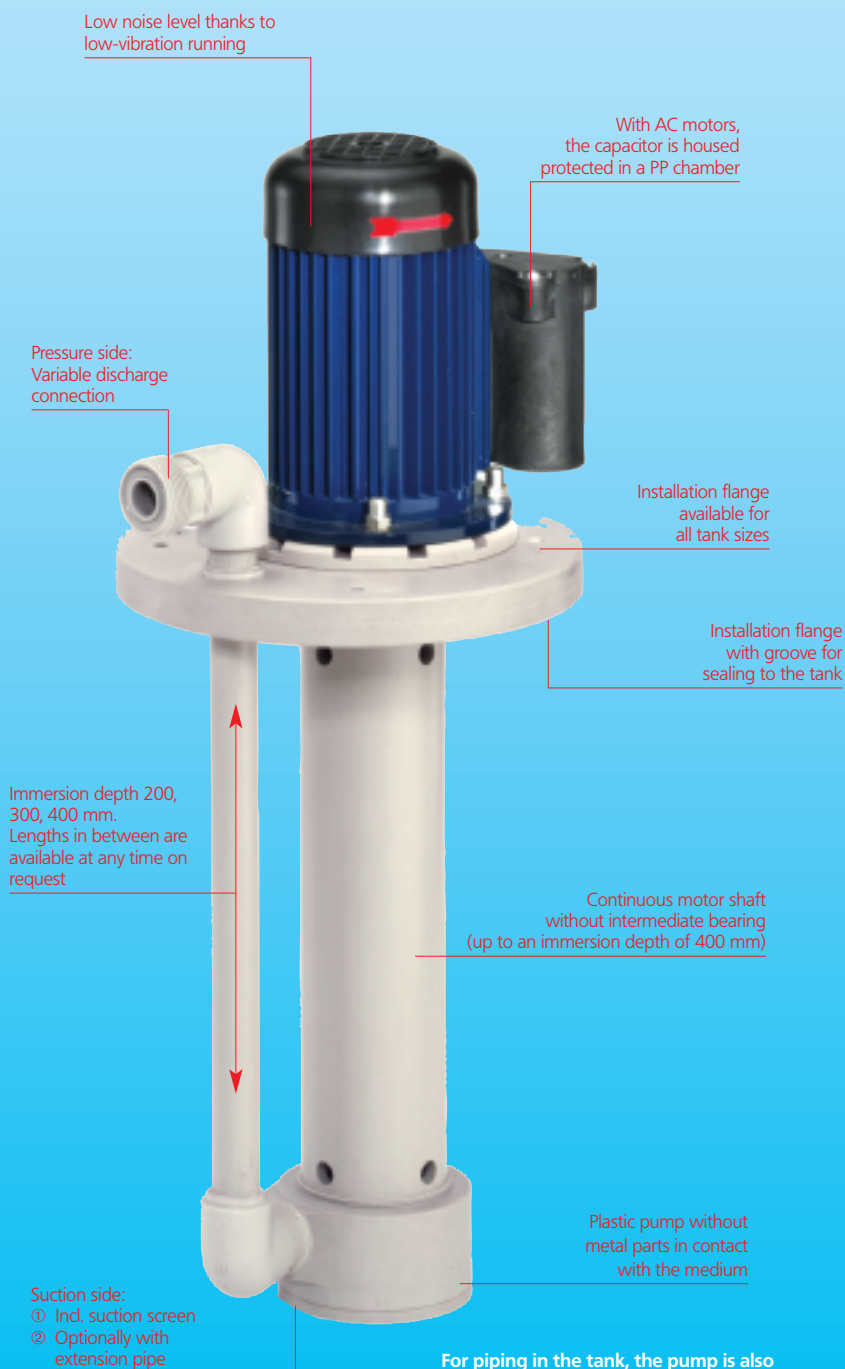

For piping in the tank, the pump is also available without a pressure pipe.

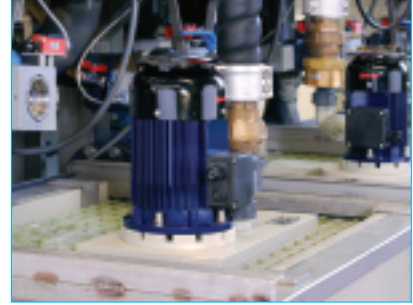

Note

Please refer to the detailed technical information on Pages 5 to 11, which applies to all modules.

Dimensions in mm

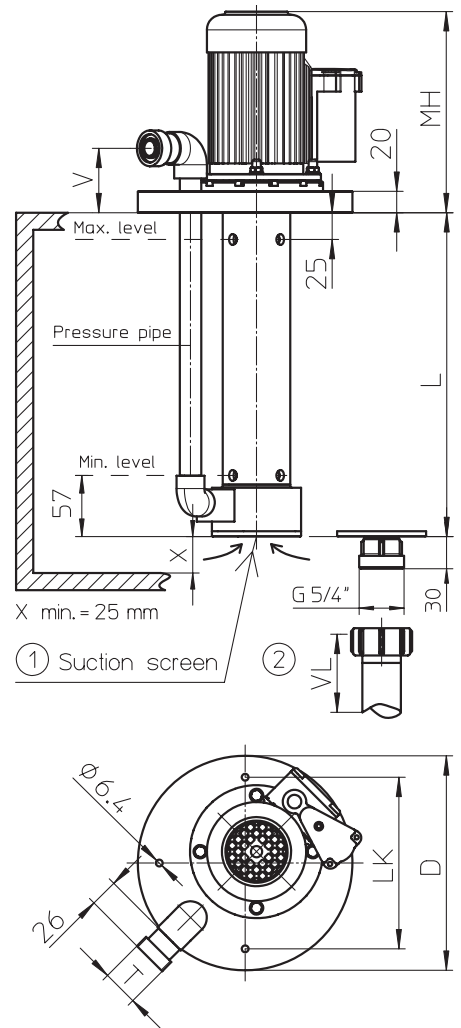

Installation opening

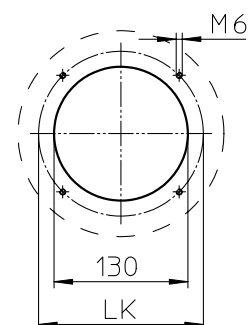

Precise documentation ensures planning reliability for your construction

On the basis of exact performance data, you can choose the exact pump that you need for your plants.

The Renner design and production principle also allows individual solutions to be realised.

Accessories

- Extension pipe VL max. = 500 mm
- On/Off switch on terminal box
- Connecting cable completely wired with plug

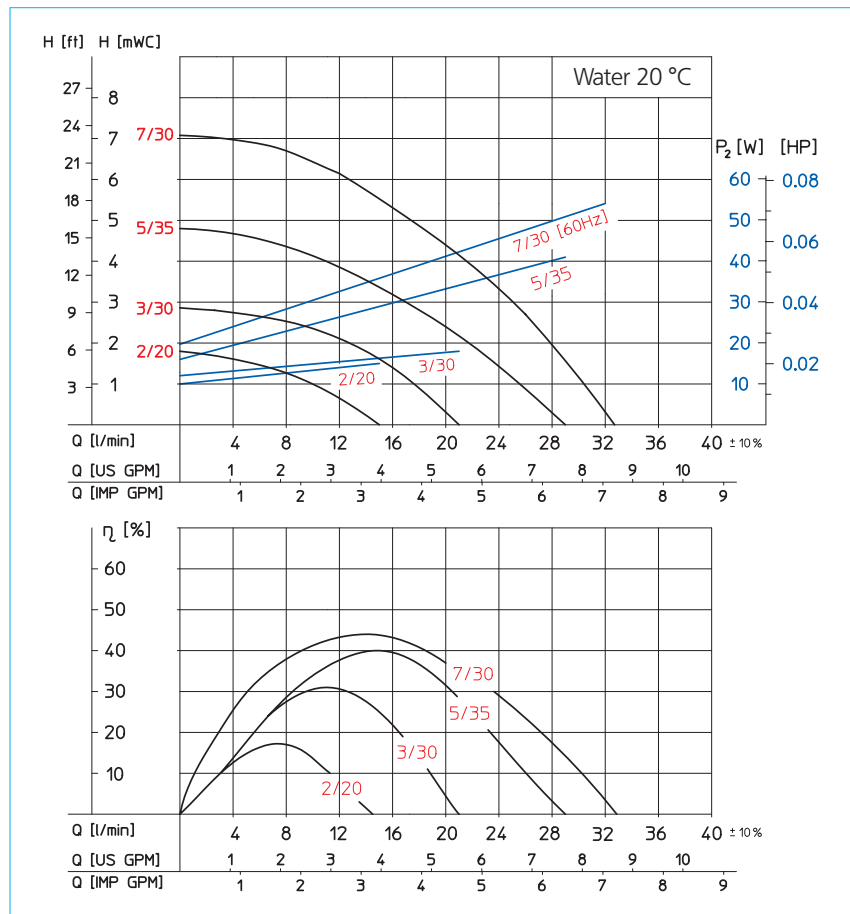

Size		2/20	3/30	5/35	7/30
Hydraulic data					
Max. delivery rate	[l/min / US GPM]	15 / 4	20 / 5.3	30 / 7.9	32 / 8.45
Max. delivery head	[mWC / ft.]	1.7 / 5.6'	2.8 / 9.2'	5 / 16.4'	7 / 23'
Motor data					
Motor power P ₂ *	[W / HP]	60 / 0.1	60 / 0.1	60 / 0.1	-
Motor power P ₂ *	[W / HP]	72 / 0.1	72 / 0.1	72 / 0.1	72 / 0.1
Speed at 50 Hz	[rpm]	2850	2850	2850	-
Speed at 60 Hz	[rpm]	3450	3450	3450	3450
Voltage		230 V 1-ph. or 230/400 V 3-ph. **			
Protection type		IP55 ***			
Dimensions					
Installation height [MH]	[mm / inch]	1875 / 73.8"	1875 / 73.8"	1875 / 73.8"	1875 / 73.8"
Connections	Suction side ①	Suction screen	Suction screen	Suction screen	Suction screen
	Suction side ②	G 5/4	G 5/4	G 5/4	G 5/4
	Pressure side [T]	G 1	G 1	G 1	G 1

Immersion depth [L]	[mm / inch]	200 / 7.87"	300 / 11.8"	400 / 15.7"
Discharge connection height [V]	[mm / inch]	Standard = 60 / 2.36" alternatively with other dimensions, rotatable, vertically upwards etc.		
Installation flange [D], [LK]	[mm / inch]	Ø 200 / 7.87", LK 160 / 6.3" other dimensions always possible, also available as a rectangular flange		

* All pumps are also available with smaller impeller diameters for liquids with higher specific gravities although this reduces the delivery rates and delivery heads. If necessary, please consult us.

** All international voltages and frequencies are available.

*** Other protection types on request.

VERTICAL CENTRIFUGAL IMMERSION PUMP SERIES RT1.5

safe to run dry without shaft
intermediate bearing up to an
immersion depth of 500 mm

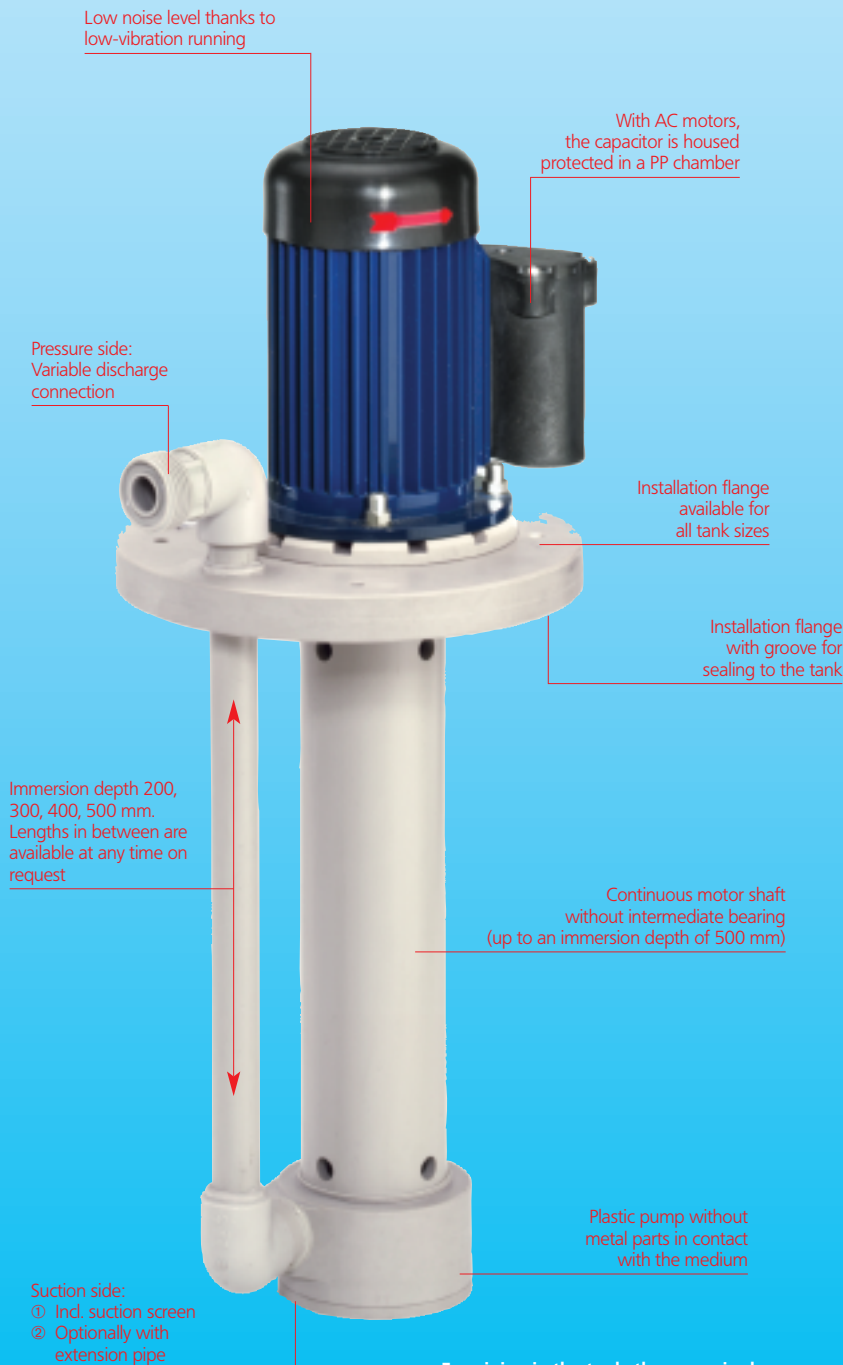

Note

Please refer to the detailed technical information on Pages 5 to 11, which applies to all modules.

Dimensions in mm

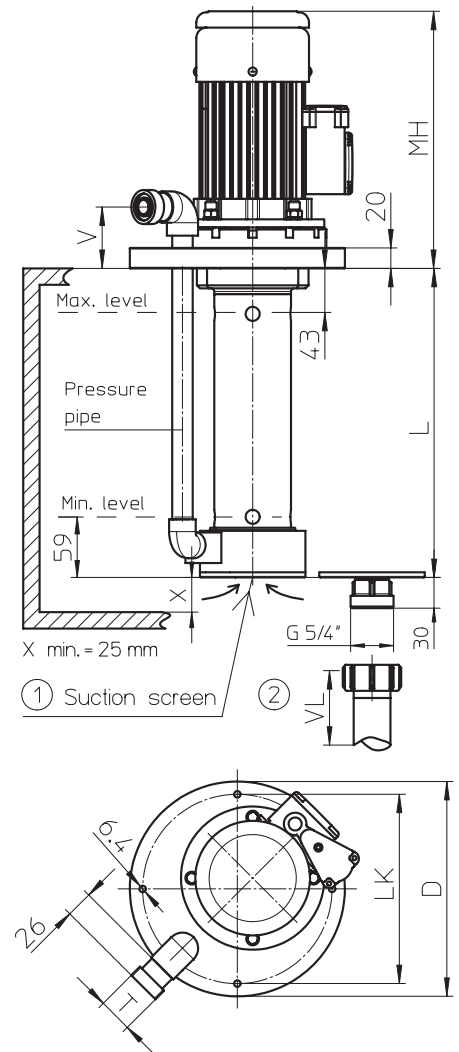

Installation opening

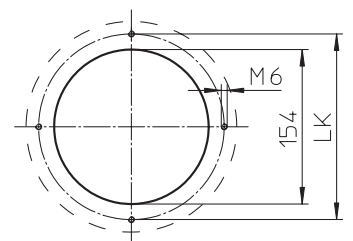

For piping in the tank, the pump is also available without a pressure pipe.

Precise documentation ensures planning reliability for your construction

On the basis of exact performance data, you can choose the exact pump that you need for your plants.

The Renner design and production principle also allows individual solutions to be realised.

Accessories

- Extension pipe VL max. = 500 mm
- On/Off switch on terminal box
- Connecting cable completely wired with plug

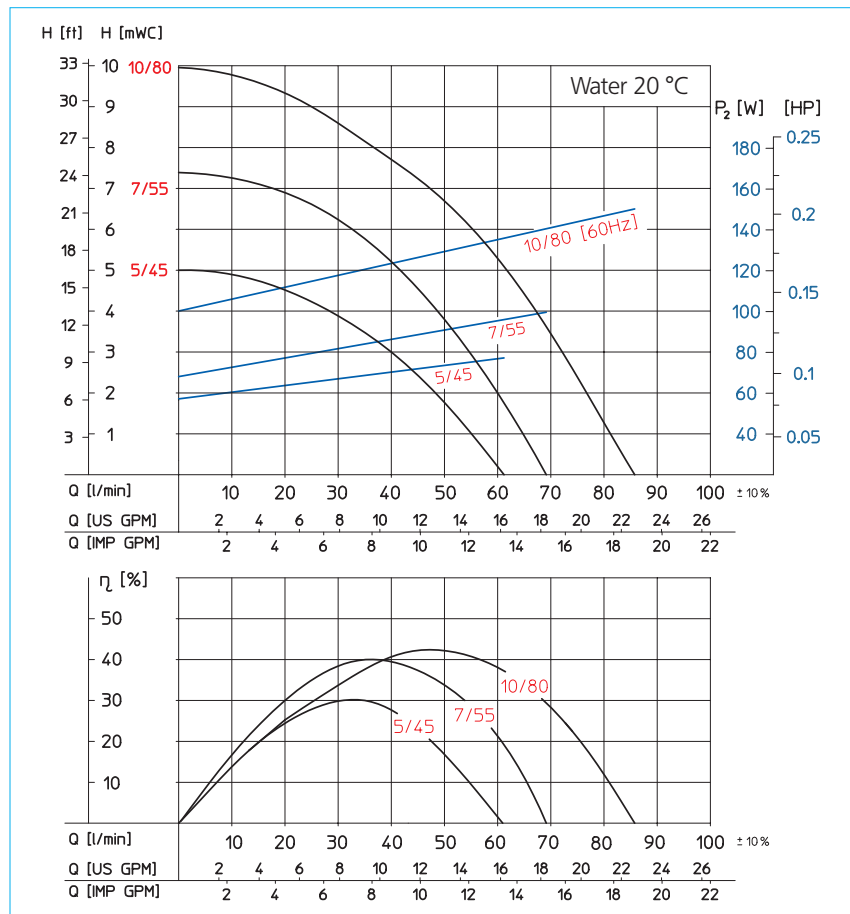

Size		5/45	7/55	10/80
Hydraulic data				
Max. delivery rate	[l/min / US GPM]	60 / 15.8	70 / 18.5	85 / 22.5
Max. delivery head	[mWC / ft.]	5 / 16.4'	7.5 / 23'	10 / 32.8'
Motor data				
Motor power P ₂ * at 50 Hz	[W / HP]	120 / 0.15	120 / 0.15	-
Motor power P ₂ * at 60 Hz	[W / HP]	144 / 0.2	144 / 0.2	180 / 0.25
Speed at 50 Hz	[rpm]	2850	2850	-
Speed at 60 Hz	[rpm]	3450	3450	3450
Voltage		230 V 1-ph. or 230/400 V 3-ph. **		
Protection type		IP55 ***		
Dimensions				
Installation height [MH]	[mm / inch]	225 / 8.86"	225 / 8.86"	230 / 9.05"
Connections	Suction side ①	Suction screen		Suction screen
	Suction side ②	G 5/4	G 5/4	G 5/4
	Pressure side [T]	G 1	G 1	G 1

Immersion depth L	[mm / inch]	200 / 7.87"	300 / 11.8"	400 / 15.7"	500 / 19.7"
Discharge connection height [V]	[mm / inch]	Standard = 60 / 2.36" alternatively with other dimensions, rotatable, vertically upwards etc.			
Installation flange [D], [LK]	[mm / inch]	Ø 210 / 8.27", LK 185 / 7.28" other dimensions always possible, also available as a rectangular flange			

* All pumps are also available with smaller impeller diameters for liquids with higher specific gravities although this reduces the delivery rates and delivery heads. If necessary, please consult us.

** All international voltages and frequencies are available.

*** Other protection types on request.

VERTICAL CENTRIFUGAL IMMERSION PUMP SERIES RT2

safe to run dry without shaft
intermediate bearing up to an
immersion depth of 500 mm

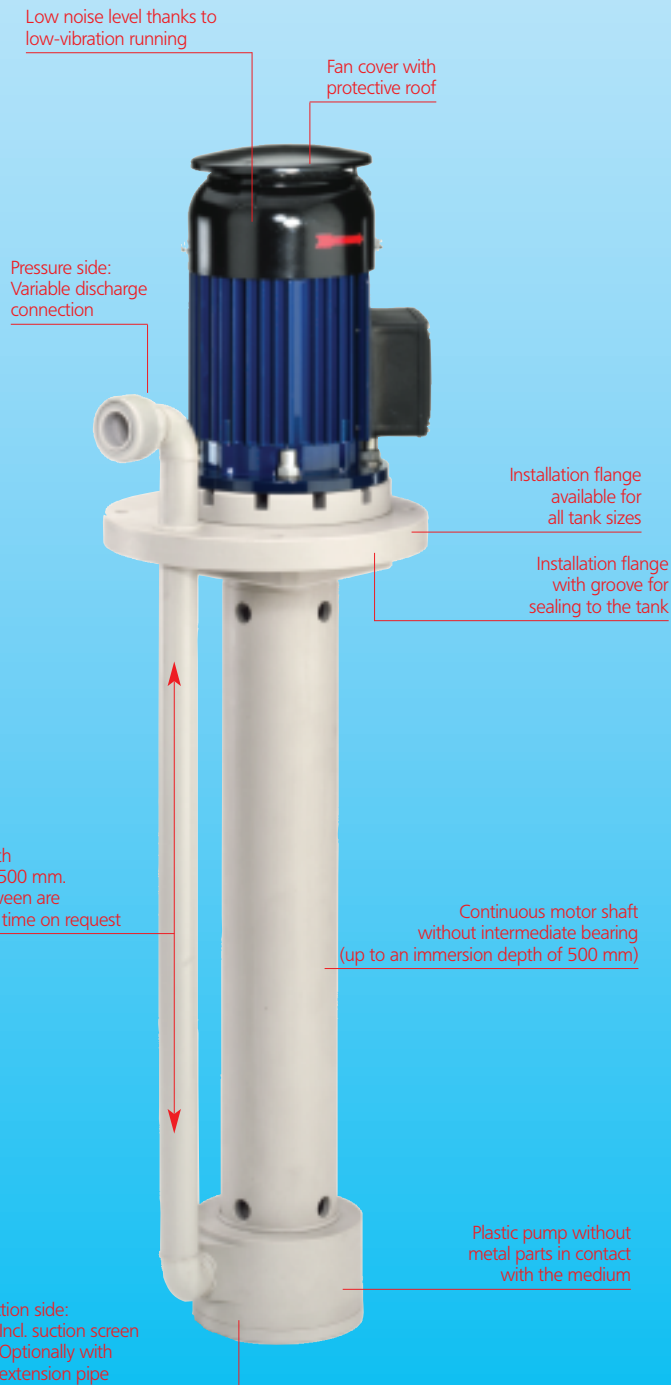

Note

Please refer to the detailed technical information on Pages 5 to 11, which applies to all modules.

Dimensions in mm

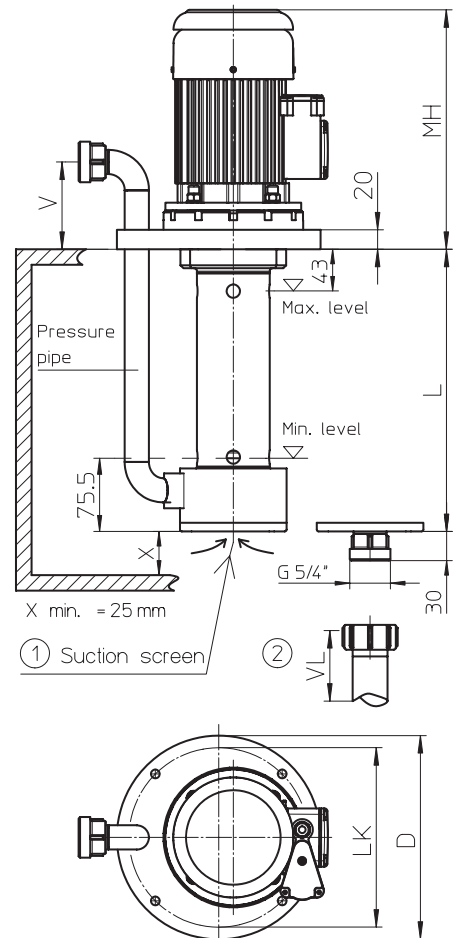

Installation opening

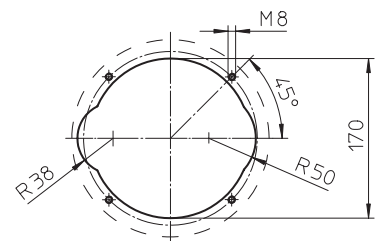

Precise documentation ensures planning reliability for your construction

On the basis of exact performance data, you can choose the exact pump that you need for your plants.

The Renner design and production principle also allows individual solutions to be realised.

Accessories

- Extension pipe VL max. = 500 mm
- Connecting cable completely wired with plug

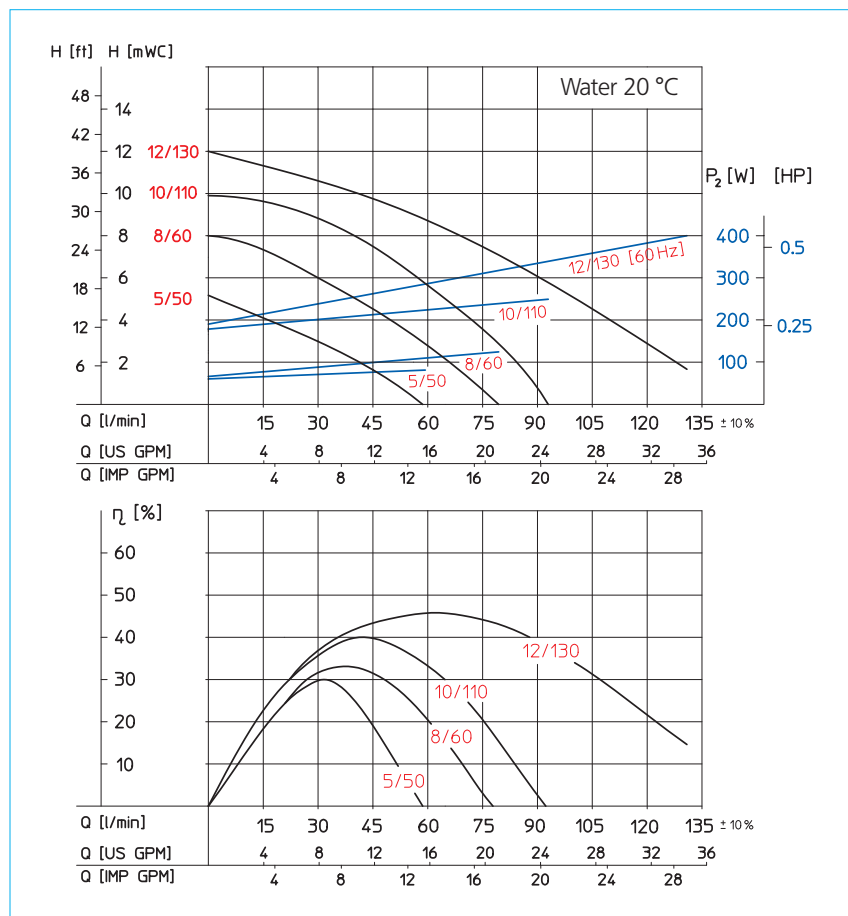

Size	5/50	8/60	10/110	12/130
Hydraulic data				
Max. delivery rate [l/min / US GPM]	60 / 15.8	75 / 19.8	100 / 26.4	130 / 34.3
Max. delivery head [mWC / ft.]	5 / 16.4'	8 / 26.2'	10 / 32.8'	12 / 39.4'
Motor data				
Motor power P ₂ * at 50 Hz [W / HP]	125 / 0.2	180 / 0.25	250 / 0.35	-
Motor power P ₂ * at 60 Hz [W / HP]	150 / 0.2	200 / 0.25	300 / 0.4	440 / 0.6
Speed at 50 Hz [rpm]	2850	2850	2850	-
Speed at 60 Hz [rpm]	3450	3450	3450	3450
Voltage	230 V 1-ph. or 230/400 V 3-ph. **			
Protection type	IP55 ***			
Dimensions				
Installation height [MH] [mm / inch]	235 / 9.25"	240 / 9.45"	257 / 10.1"	257 / 10.1"
Connections	Suction screen			
Suction side ①	Suction screen			
Suction side ②	G 5/4			
Pressure side [T]	G 1			

Immersion depth L [mm / inch]	200 / 7.87"	300 / 11.8"	400 / 15.7"	500 / 19.7"
Discharge connection height [V] [mm / inch]	Standard = 90 / 3.54" alternatively with other dimensions, rotatable, vertically upwards etc.			
Installation flange [D], [LK] [mm / inch]	Ø 210 / 8.27", LK 185 / 7.28" other dimensions always possible, also available as a rectangular flange			

* All pumps are also available with smaller impeller diameters for liquids with higher specific gravities although this reduces the delivery rates and delivery heads. If necessary, please consult us.

** All international voltages and frequencies are available.

*** Other protection types on request.

VERTICAL CENTRIFUGAL IMMERSION PUMP

Series RT3

safe to run dry without shaft
intermediate bearing up to an
immersion depth of 500 mm

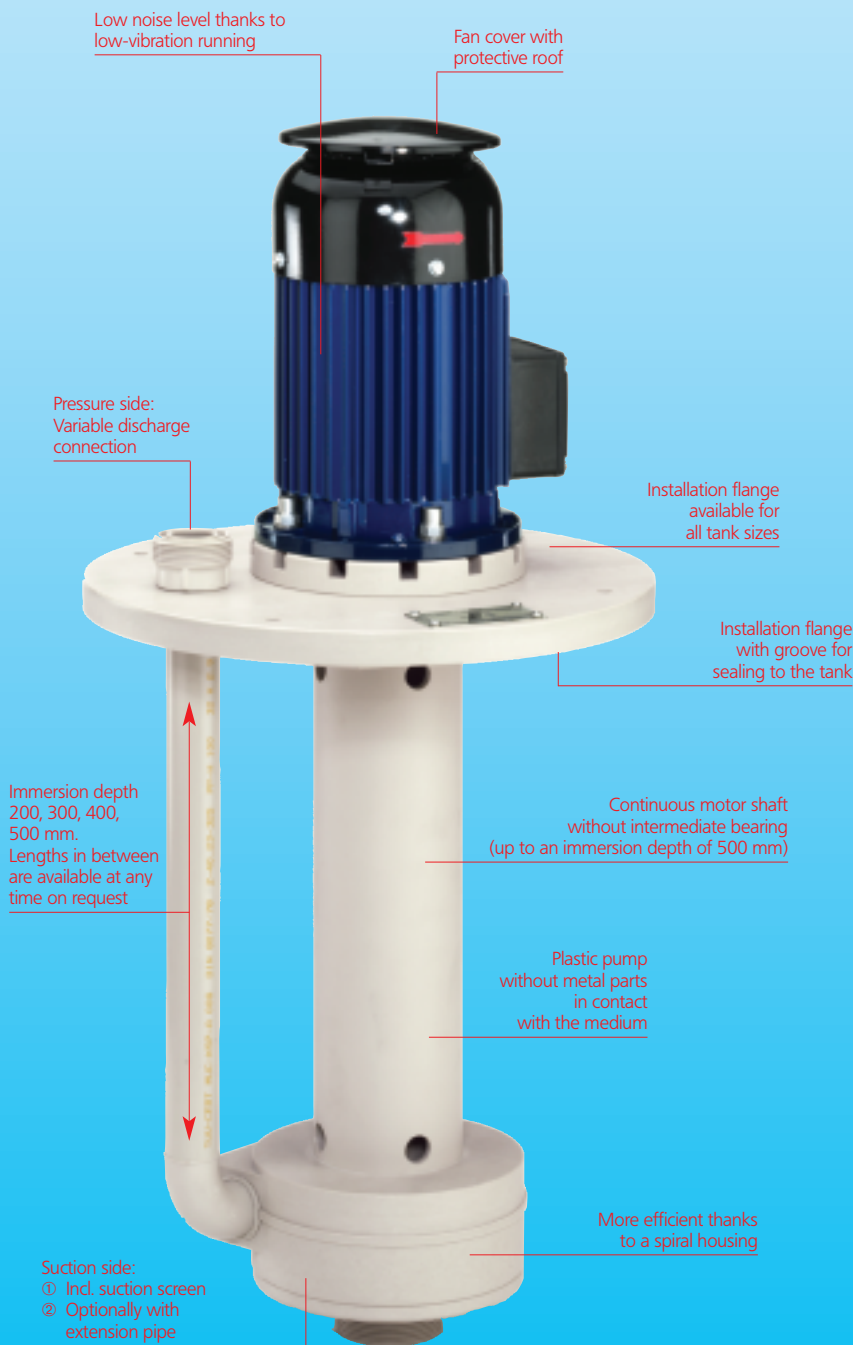

Note

Please refer to the detailed technical information on Pages 5 to 11, which applies to all modules.

Dimensions in mm

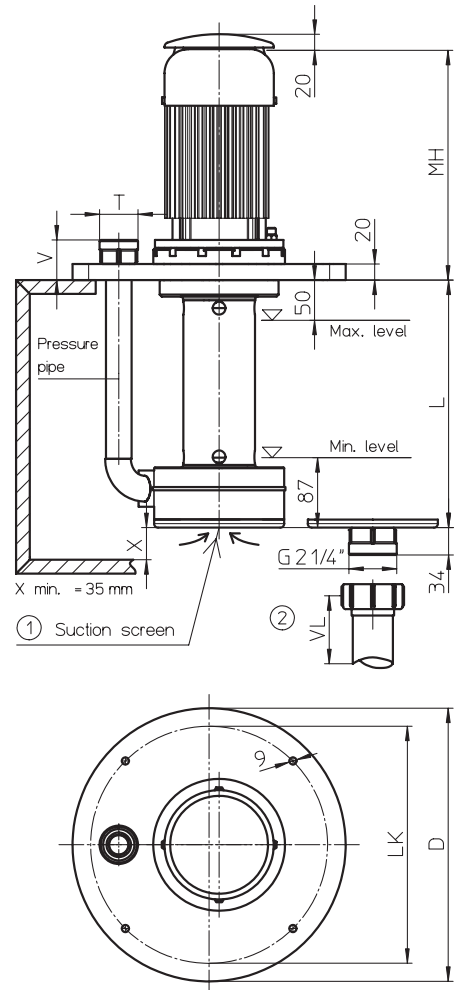

Installation opening

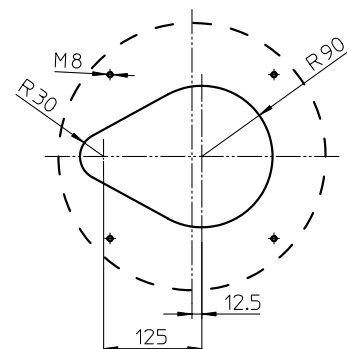

For piping in the tank, the pump is also available without a pressure pipe.

Precise documentation ensures planning reliability for your construction

On the basis of exact performance data, you can choose the exact pump that you need for your plants.

The Renner design and production principle also allows individual solutions to be realised.

Accessories

- Extension pipe VL max. = 500 mm
- Connecting cable completely wired with plug

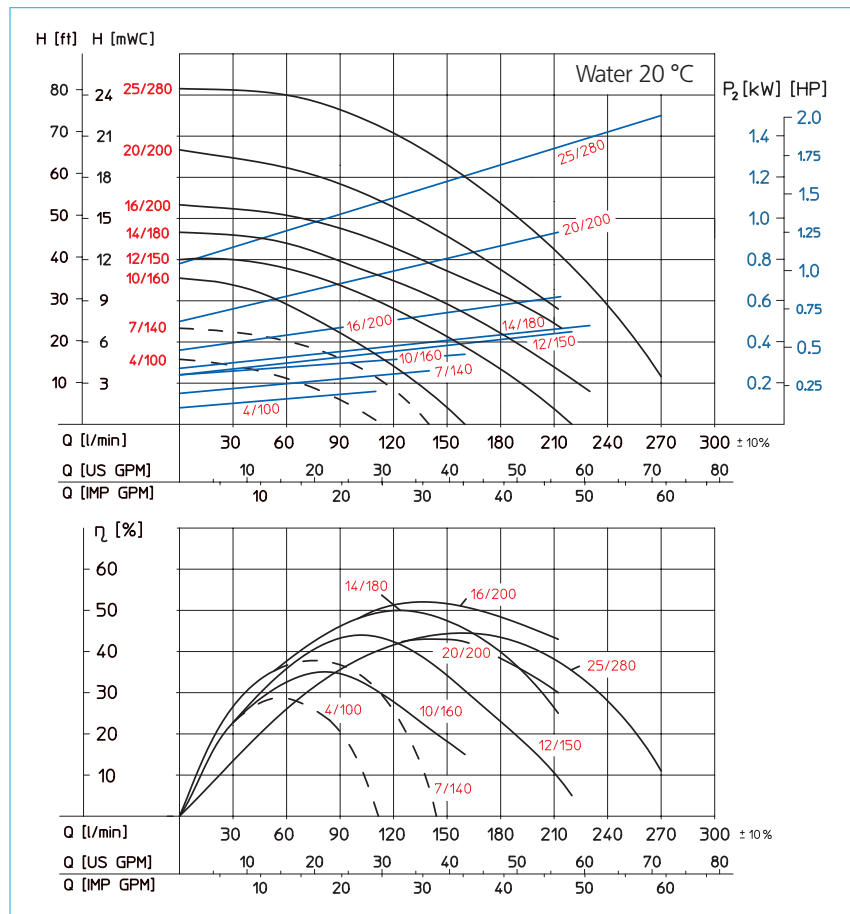

Size	4/100	7/140	10/160	12/150	14/180	16/200	20/200	25/280
Hydraulic data								
Max. delivery rate [l/min / US GPM]	100 / 26.4	140 / 37	160 / 42.3	220 / 58.1	230 / 60.8	210 / 55.5	210 / 55.5	280 / 74
Max. delivery head [mWC / ft.]	5 / 16.4'	7 / 23'	10 / 32.8'	12 / 39.4'	14 / 45.9'	16 / 52.5'	20 / 65.6'	25 / 82'
Motor data								
Motor power P ₂ * at 50 Hz [kW / HP]	0.25 / 0.35	-	0.37 / 0.5	0.55 / 0.75	0.55 / 0.75	0.65 / 1	1.1 / 1.5	-
Motor power P ₂ * at 60 Hz [kW / HP]	0.3 / 0.4	0.3 / 0.4	0.44 / 0.6	0.65 / 1	0.65 / 1	0.7 / 1	1.3 / 1.75	1.8 / 2.5
Speed at 50 Hz [rpm]	1450	-	2850	2850	2850	2850	2850	-
Speed at 60 Hz [rpm]	1750	1750	3450	3450	3450	3450	3450	3450
Voltage	230 V 1-ph. or 230/400 V 3-ph. **							
Protection type	IP55 ***							
Dimensions								
Installation height [MH] [mm / inch]	292 / 11.5"	292 / 11.5"	276 / 10.9"	292 / 11.5"	292 / 11.5"	292 / 11.5"	310 / 12.2"	310 / 12.2"
Connections	Suction screen Suction screen Suction screen Suction screen Suction screen Suction screen Suction screen Suction screen							
Suction side ①	G 2 1/4 G 2 1/4 G 2 1/4 G 2 1/4 G 2 1/4 G 2 1/4 G 2 1/4 G 2 1/4							
Suction side ②	G 2 1/4 G 2 1/4 G 2 1/4 G 2 1/4 G 2 1/4 G 2 1/4 G 2 1/4 G 2 1/4							
Pressure side [T]	G 2 1/4 G 2 1/4 G 1 1/2 G 1 1/2 G 1 1/2 G 1 1/2 G 1 1/2 G 1 1/2							

Immersion depth L [mm / inch]	200 / 7.87"	300 / 11.8"	400 / 15.7"	500 / 19.7"
Discharge connection height [V] [mm / inch]	Standard = 50 / 1.97" alternatively with other dimensions, rotatable, with angle 90° etc.			
Installation flange [D], [LK] [mm / inch]	Ø 340 / 13.4", LK 295 / 11.6" other dimensions always possible, also available as a rectangular flange			

* All pumps are also available with smaller impeller diameters for liquids with higher specific gravities although this reduces the delivery rates and delivery heads. If necessary, please consult us.

** All international voltages and frequencies are available.

*** Other protection types on request.

VERTICAL CENTRIFUGAL IMMERSION PUMP

Series RT4

safe to run dry without shaft
intermediate bearing up to an
immersion depth of 500 mm

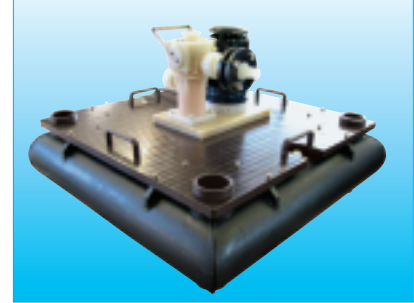

Note

Please refer to the detailed technical information on Pages 5 to 11, which applies to all modules.

Dimensions in mm

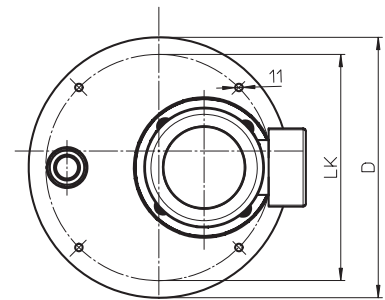
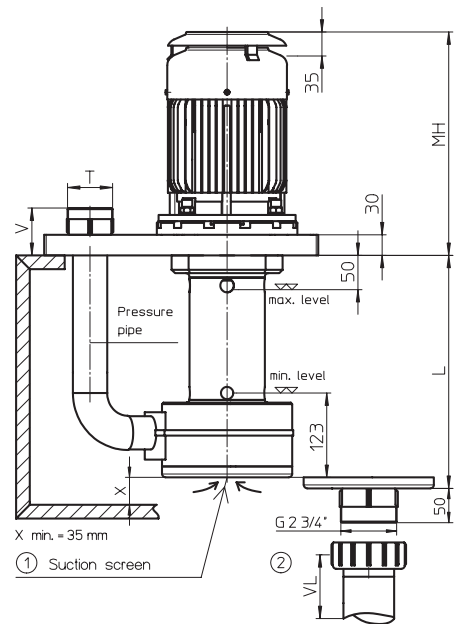

Installation opening

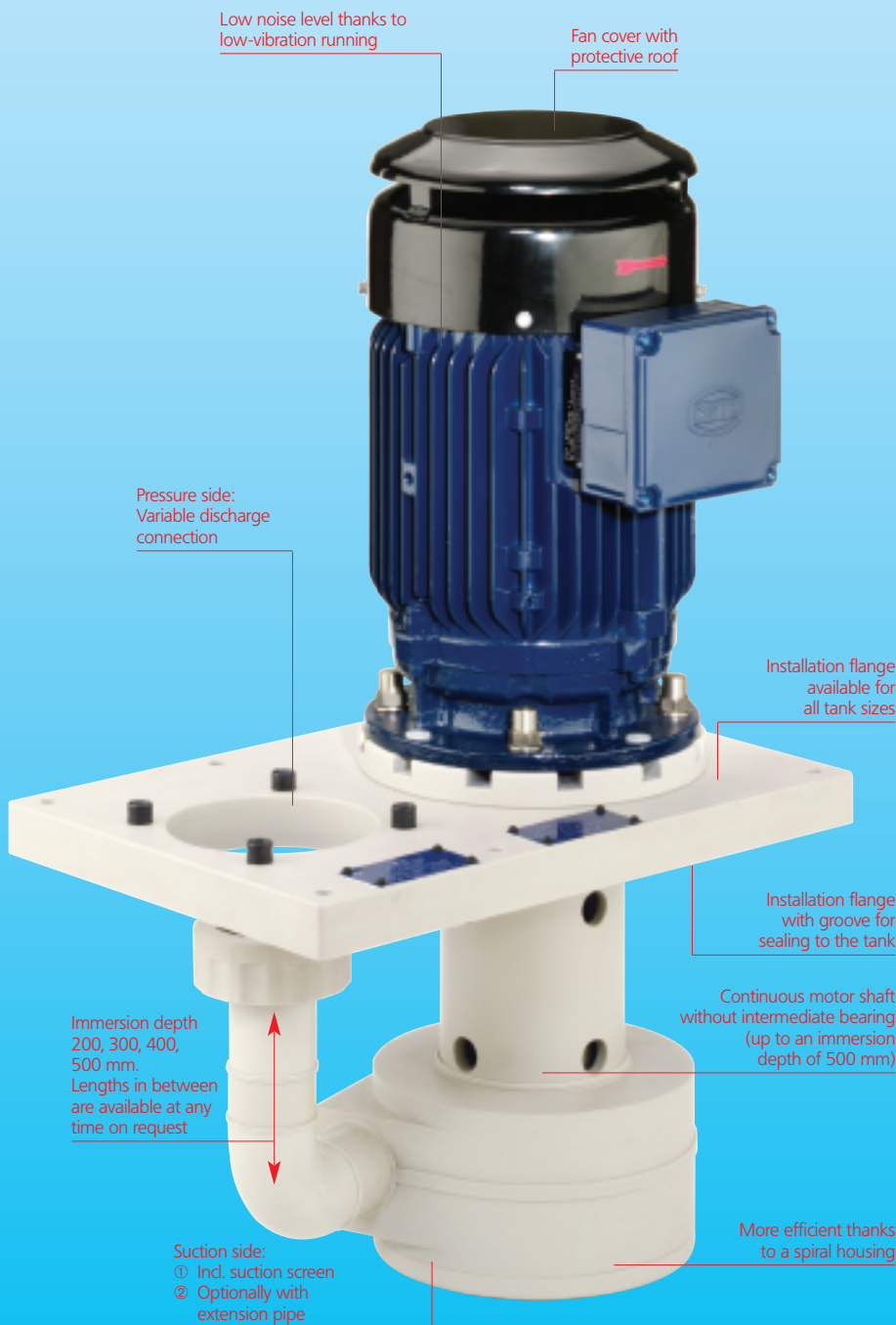
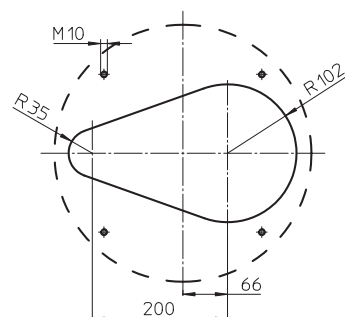

For piping in the tank, the pump is also available without a pressure pipe.

Precise documentation ensures planning reliability for your construction

On the basis of exact performance data, you can choose the exact pump that you need for your plants.

The Renner design and production principle also allows individual solutions to be realised.

Accessories

- Extension pipe VL max. = 500 mm
- Connecting cable completely wired with plug

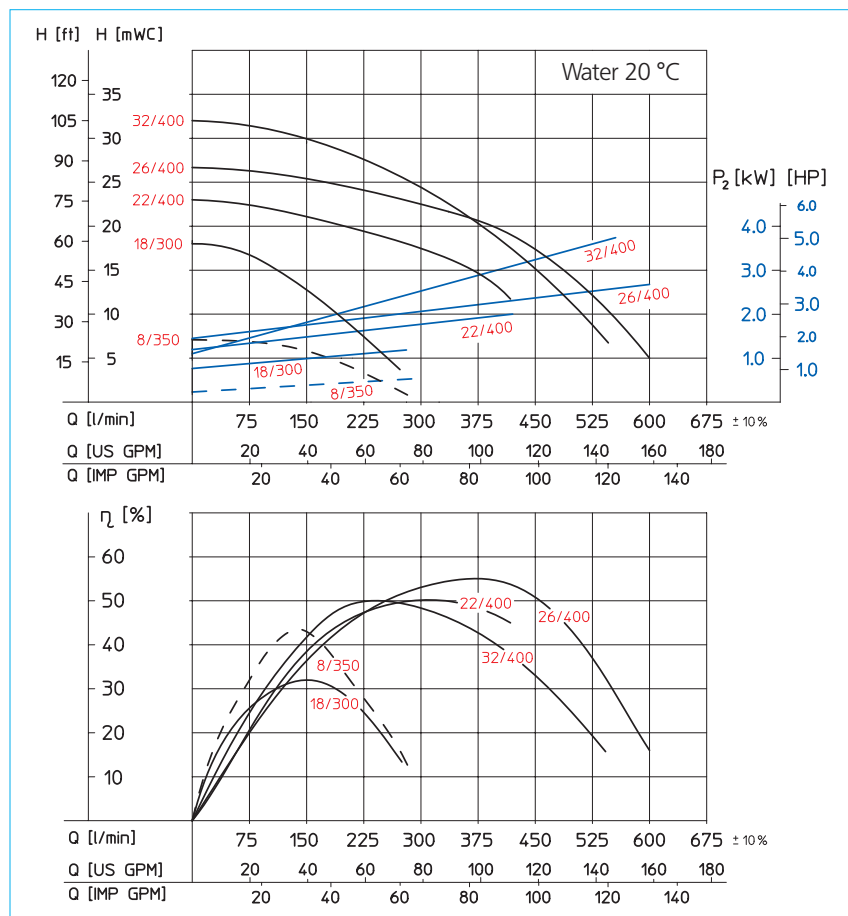

Size		8/350	18/300	22/400	26/400	32/400
Hydraulic data						
Max. delivery rate	[l/min / US GPM]	300 / 79.3	300 / 79.3	400 / 105.7	600 / 158.5	550 / 145
Max. delivery head	[mWC / ft.]	7 / 23'	18 / 59'	23 / 75.5'	26 / 85.3'	32 / 105'
Motor data						
Motor power P ₂ *	[kW / HP]	1.1 / 1.5	1.1 / 1.5	1.8 / 2.5	3.7 / 5	3.7 / 5
Motor power P ₂ *	[kW / HP]	1.3 / 1.8	1.3 / 1.8	2 / 2.7	3.7 / 5	3.7 / 5
Speed at 50 Hz	[rpm]	1450	2850	2850	2850	2850
Speed at 60 Hz	[rpm]	1750	3450	3450	3450	3450
Voltage		230/400 V 3-ph. **				
Protection type		IP55 ***				
Dimensions						
Installation height [MH]	[mm / inch]	350 / 13.8"	294 / 11.6"	291 / 11.4"	316 / 12.4"	316 / 12.4"
Connections	Suction side ①	Suction screen	Suction screen	Suction screen	Suction screen	Suction screen
	Suction side ②	G 2 3/4	G 2 3/4	G 2 3/4	G 2 3/4	G 2 3/4
	Pressure side [T]	G 2 1/4	G 2 1/4	G 2 1/4	G 2 1/4	G 2 1/4

Immersion depth L	[mm / inch]	200 / 7.87"	300 / 11.8"	400 / 15.7"	500 / 19.7"	
Discharge connection height [V]	[mm / inch]	Standard = 69 / 2.7" alternatively with other dimensions, rotatable, with angle 90° etc.				
Installation flange [D], [LK]	[mm / inch]	Ø 380 / 15", LK 330 / 13" other dimensions always possible, also available as a rectangular flange				

* All pumps are also available with smaller impeller diameters for liquids with higher specific gravities although this reduces the delivery rates and delivery heads. If necessary, please consult us.

** All international voltages and frequencies are available.

*** Other protection types on request.

VERTICAL CENTRIFUGAL IMMERSION PUMP

Series RT5

safe to run dry without shaft intermediate bearing up to an immersion depth of 500 mm

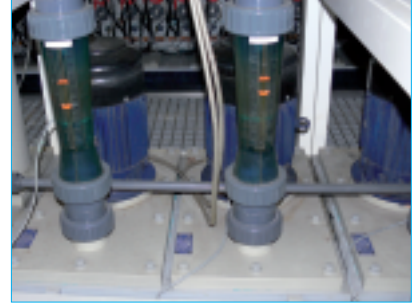

Note

Please refer to the detailed technical information on Pages 5 to 11, which applies to all modules.

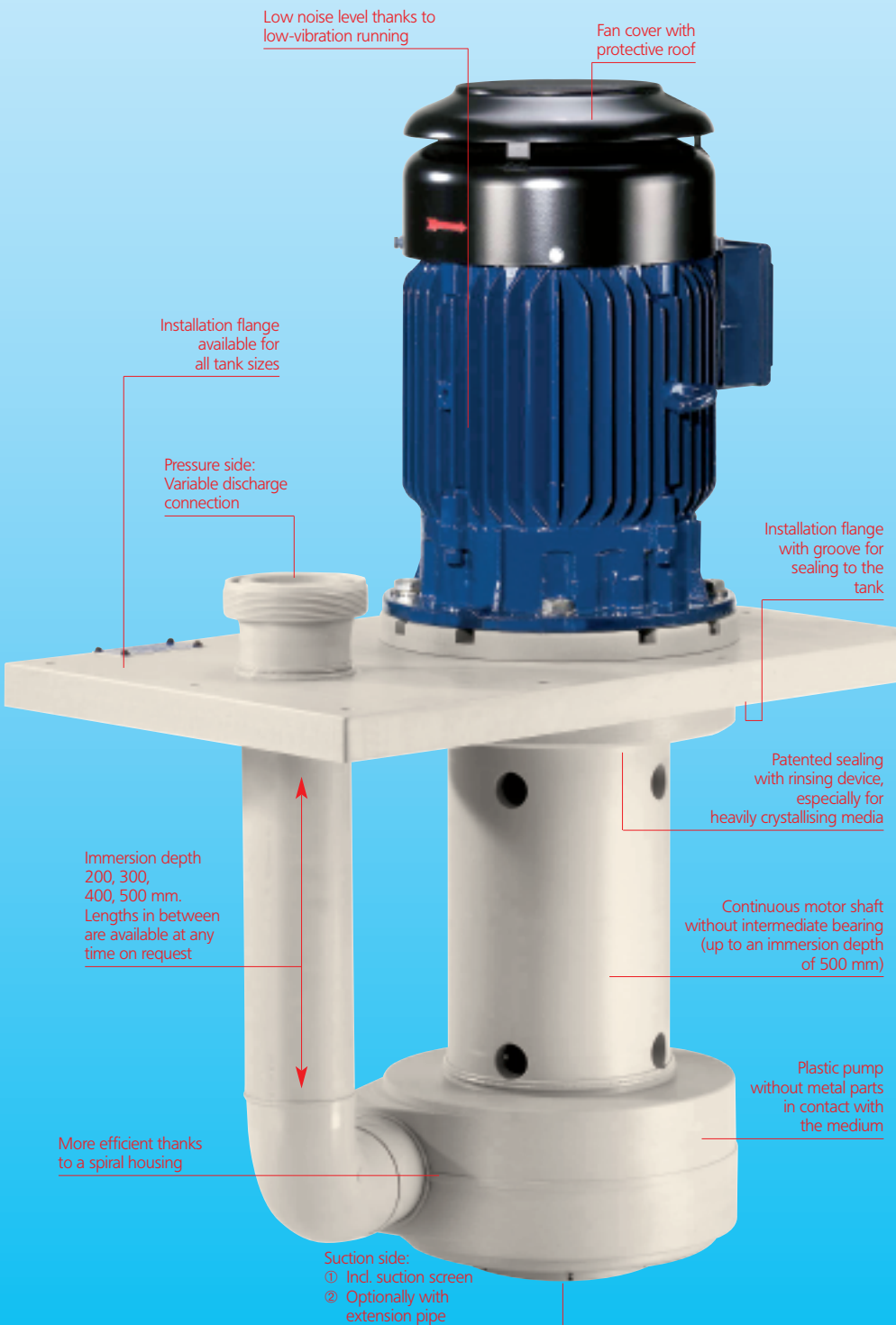

Dimensions in mm

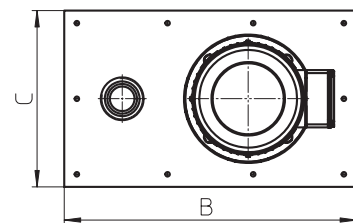
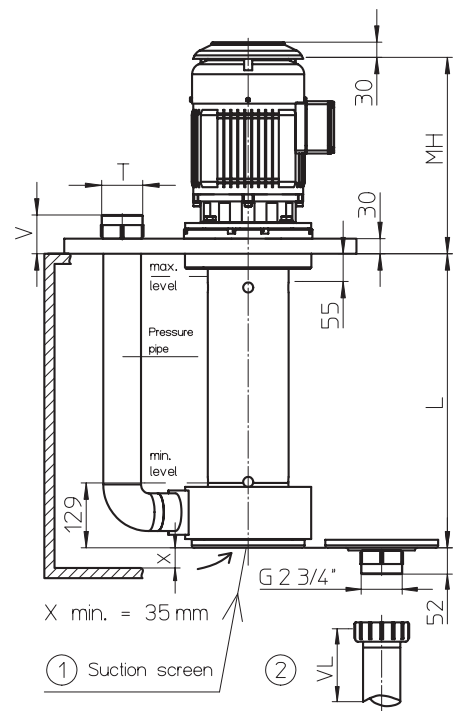

Installation opening

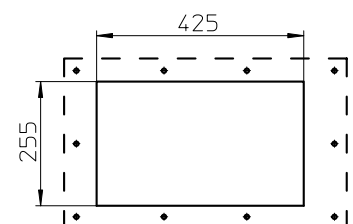

For piping in the tank, the pump is also available without a pressure pipe.

Precise documentation ensures planning reliability for your construction

On the basis of exact performance data, you can choose the exact pump that you need for your plants.

The Renner design and production principle also allows individual solutions to be realised.

Accessories

- Extension pipe VL max. = 500 mm
- Connecting cable completely wired with plug

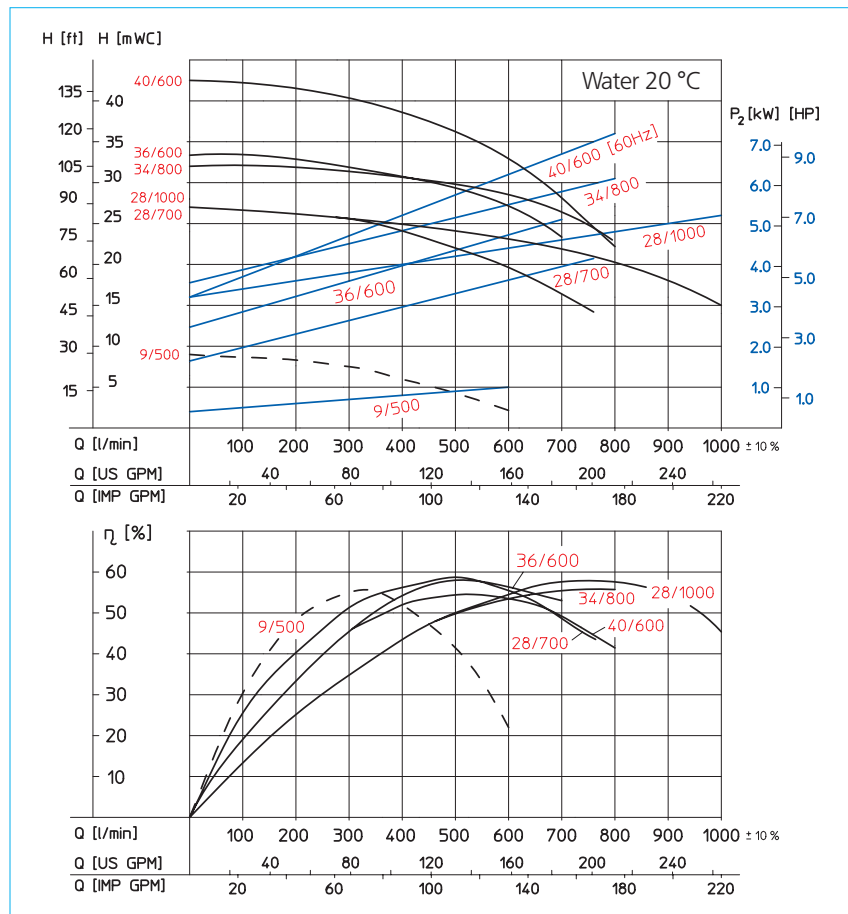

Size		9/500	28/700	36/600	34/800	28/1000	40/600
Hydraulic data							
Max. delivery rate	[l/min / US GPM]	600 / 158.5	750 / 198	700 / 185	800 / 211	1000 / 264	680 / 180
Max. delivery head	[mWC / ft.]	9 / 29.5'	28 / 92'	34 / 111.5'	32 / 105'	28 / 92'	42 / 138'
Motor data							
Motor power P ₂ * at 50 Hz	[kW / HP]	1.8 / 2.5	4 / 5.5	4 / 5.5	5.5 / 7.5	5.5 / 7.5	-
Motor power P ₂ * at 60 Hz	[kW / HP]	2 / 2.7	4.8 / 6.5	4.8 / 6.5	6.6 / 9	6.6 / 9	6.6 / 9
Speed at 50 Hz	[rpm]	1450	2850	2850	2850	2850	-
Speed at 60 Hz	[rpm]	1750	3450	3450	3450	3450	3450
Voltage		230/400 V or 400/690 V 3-ph. **					
Protection type		IP55 ***					
Dimensions							
Installation height [MH]	[mm / inch]	369.5 / 14.5"	369.5 / 14.5"	369.5 / 14.5"	384.5 / 15.1"	384.5 / 15.1"	384.5 / 15.1"
Connections	Suction side ①	Suction screen	Suction screen	Suction screen	Suction screen	Suction screen	Suction screen
	Suction side ②	G 2 3/4	G 2 3/4	G 2 3/4	G 2 3/4	G 2 3/4	G 2 3/4
	Pressure side [T]	G 2 3/4	G 2 3/4	G 2 1/4	G 2 3/4	G 2 3/4	G 3 1/2

Immersion depth L	[mm / inch]	270 / 10.6"	300 / 11.8"	400 / 15.7"	500 / 19.7"	
Discharge connection height [V]	[mm / inch]	Standard = 77 / 3" alternatively with other dimensions, rotatable, with angle 90° etc.				
Installation flange [B], [C]	[mm / inch]	580 x 350 / 22.8" x 13.8" other dimensions always possible, also available as a round flange				

* All pumps are also available with smaller impeller diameters for liquids with higher specific gravities although this reduces the delivery rates and delivery heads. If necessary, please consult us.

** All international voltages and frequencies are available.

*** Other protection types on request.

VERTICAL CENTRIFUGAL IMMERSION PUMP

Series RT6

safe to run dry without shaft
intermediate bearing up to an
immersion depth of 850 mm

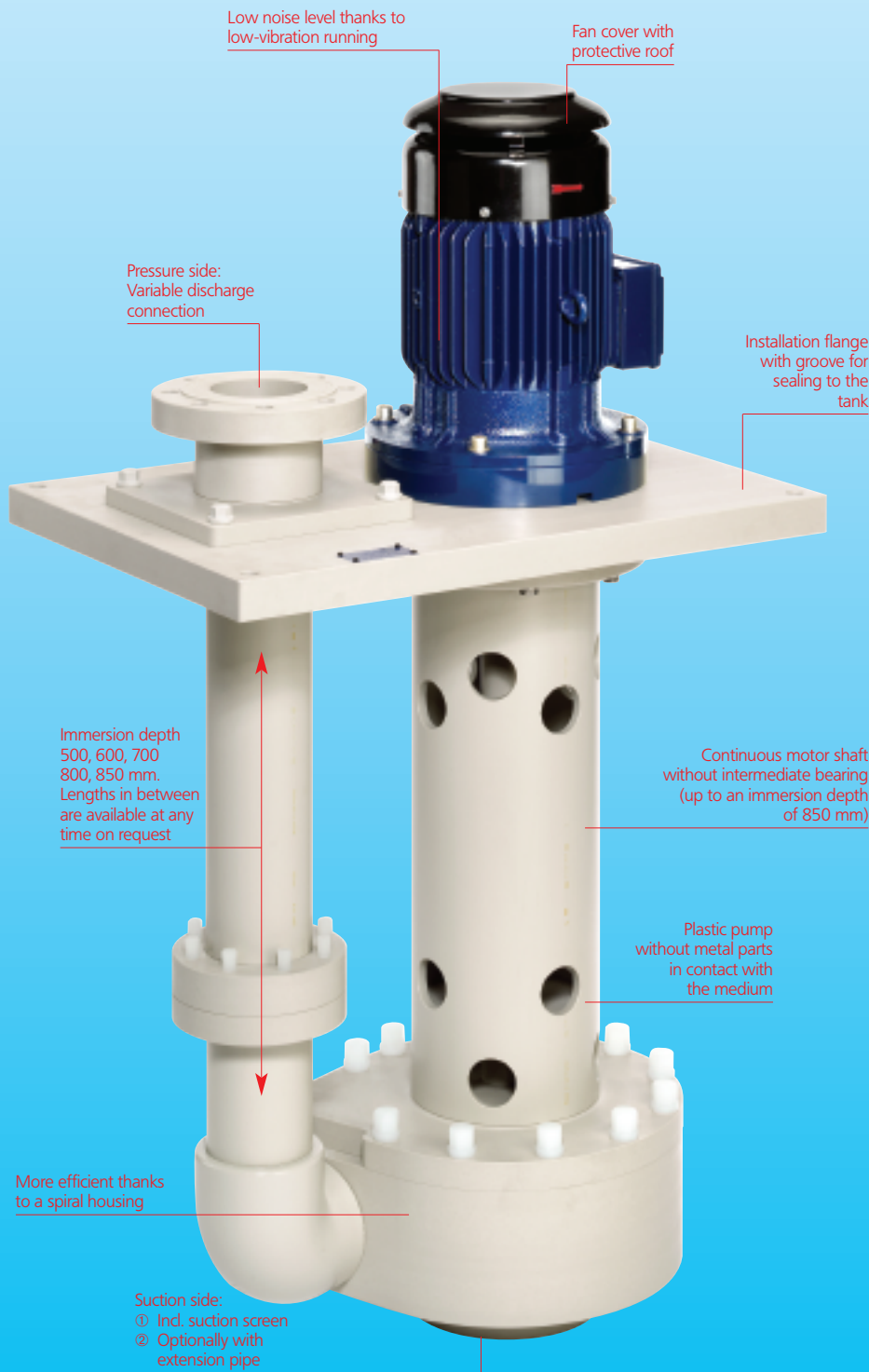

For piping in the tank, the pump is also available without a pressure pipe.



Note

Please refer to the detailed technical information on Pages 5 to 11, which applies to all modules.

Dimensions in mm

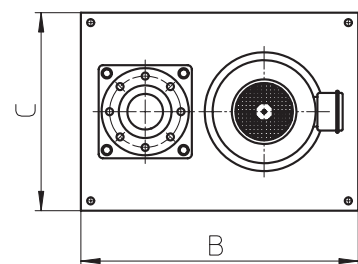
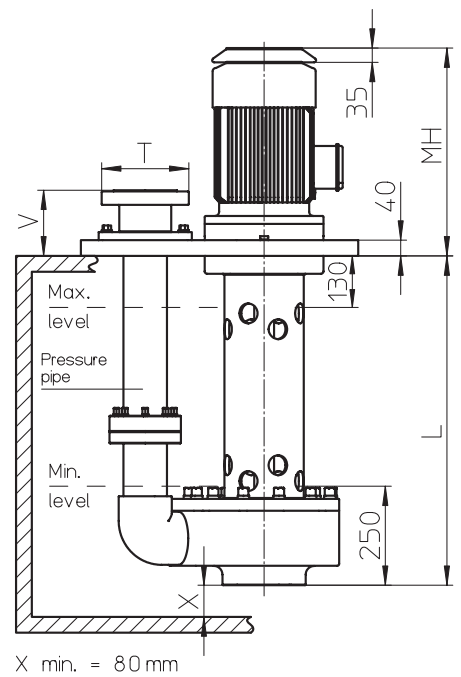

Installation opening

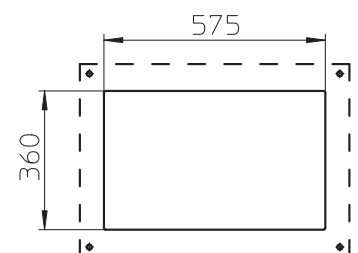

Precise documentation ensures planning reliability for your construction

On the basis of exact performance data, you can choose the exact pump that you need for your plants.

The Renner design and production principle also allows individual solutions to be realised.

Accessories

- Extension pipe VL max. = 500 mm
- Connecting cable completely wired with plug

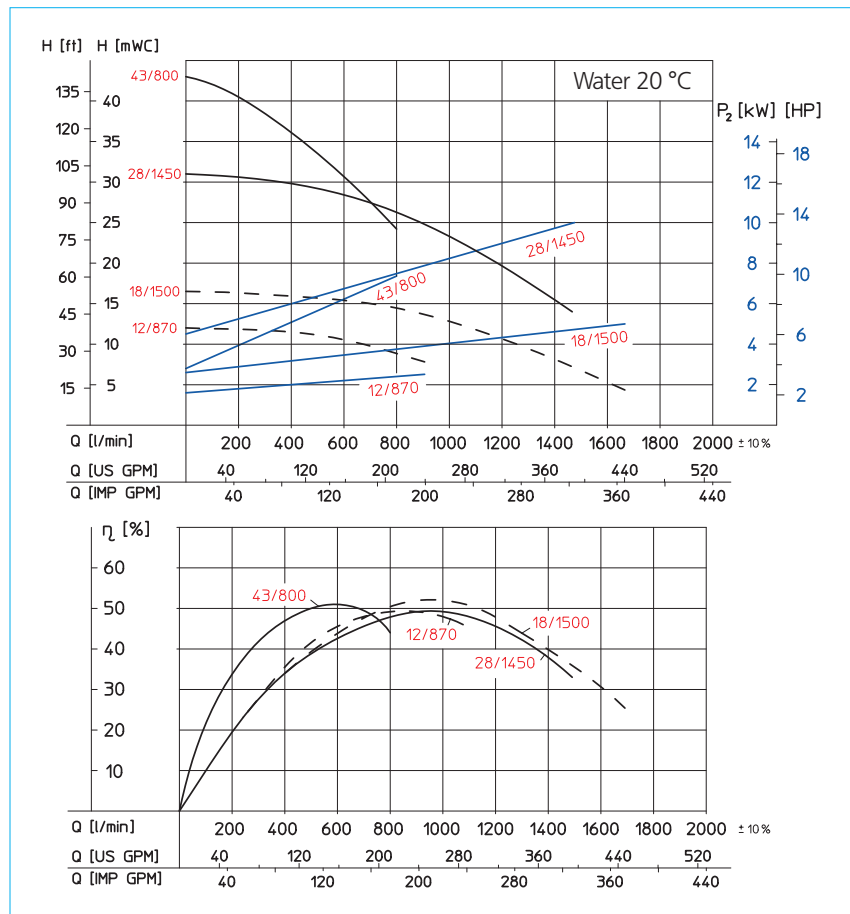

Size		12/870	18/1500	28/1450	43/800
Hydraulic data					
Max. delivery rate	[l/min / US GPM]	900 / 238	1700 / 449	1500 / 396	800 / 211
Max. delivery head	[mWC / ft.]	12 / 39.4'	17 / 55.8'	31 / 102'	43 / 141'
Motor data					
Motor power P ₂ * at 50 Hz	[kW / HP]	4 / 5.5	7.5 / 10	12.5 / 17	7.5 / 10
Motor power P ₂ * at 60 Hz	[kW / HP]	4.8 / 6.5	9 / 12	15 / 20	9 / 12
Speed at 50 Hz	[rpm]	1450	1450	2850	2850
Speed at 60 Hz	[rpm]	1750	1750	3450	3450
Voltage		400 V 3-ph. **			
Protection type		IP55 ***			
Dimensions					
Installation height [MH]	[mm / inch]	406 / 16"	518 / 20.4"	518 / 20.4"	425 / 16.7"
Connections	Suction side ①	Suction screen	Suction screen	Suction screen	Suction screen
	Suction side ②	without thread	without thread	without thread	without thread
	Pressure side [T]	Flange d110DN100	Flange d110DN100	Flange d110DN100	Thread G 2 3/4

Immersion depth L	[mm / inch]	500/19.7"	600/23.6"	700/27.5"	800/31.5"	850/33.5"
Discharge connection height [V]	[mm / inch]	Standard = 166 / 6.5" alternatively with other dimensions, rotatable, with elbow 90°, lapped flange etc.				
Installation flange [B], [C]	[mm / inch]	700 x 500 / 27.5" x 19.7" other dimensions always possible, also available as a round flange				

* All pumps are also available with smaller impeller diameters for liquids with higher specific gravities although this reduces the delivery rates and delivery heads. If necessary, please consult us.

** All international voltages and frequencies are available.

*** Other protection types on request.

COMBINATION EXAMPLES FOR RT VERTICAL CENTRIFUGAL IMMERSION PUMPS AND FILTER UNITS

For a number of applications, filter elements are required for "clean" processes.

Of course, Renner can also supply pumps and filters in a combined and compact configuration as a single unit, mounted on an installation flange.

Here, the units are optimally configured to your particular application, and are delivered ready for operation.

In terms of their construction, all filter housings are designed in such a way that they are equally suitable for holding cartridge, plate, bag and active carbon inserts.

Quick-change filter housings are available in 2 sizes for short downtimes during maintenance intervals: SF1 and SF3.



**Vertical centrifugal immersion pump
RT1 to RT5 combined with universal
filter housing, size FI-1, FI-3 or FI-4**



Series RT-FI covers a wide performance range for the filtration of all galvanic electrolytes, and also nickel zinc, currentless nickel and currentless copper. Depending on the application (safety devices are currently already installed on the plant), all universal filter housings can be fitted with a cover safety switch. Three different filter sizes with many different filter elements are available for combination with our vertical centrifugal immersion pumps. Clamping screws are used to secure the filter cover.

These filters are characterised by a compact design as well as by the possibility of using them at high pressures and high temperatures.

Universal filter housing

Size 1

Housing length [inch] 10" (1 x 10")
20" (2 x 10")

Volume [dm³] 2.36 to 4.25

Materials PP, PVDF, Plexiglas®, Jena glass®, stainless steel, titanium

Filter elements (optionally) Wound cartridge
Cloth cartridge
Membrane cartridge
Filter paper
Active carbon

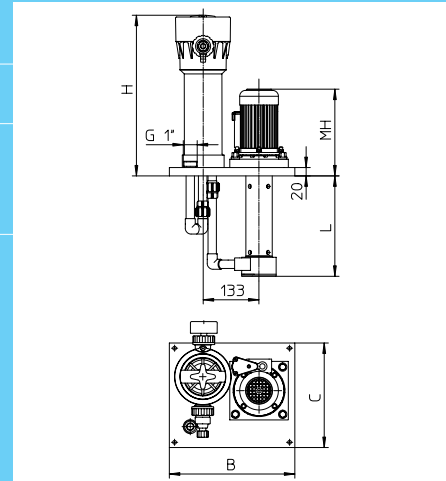

Size 3

Housing length [inch] 10" (3 x 10")
20" (6 x 10")

Volume [dm³] 8.4 to 13.5

Materials PP, PVDF, stainless steel, titanium

Filter elements (optionally) Wound cartridge
Membrane cartridge
Filter cloth, Filter sieve
Filter bag
Active carbon

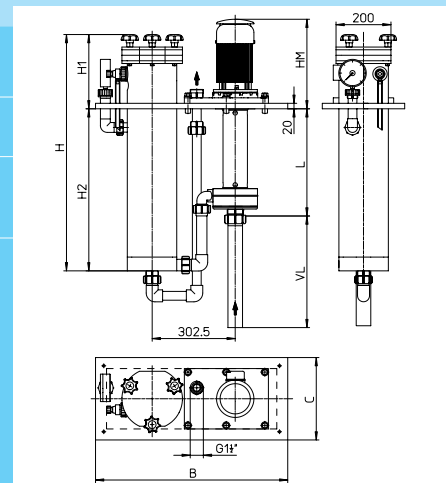

Size 4

Housing length [inch] 10" (4 x 10")
20" (8 x 10")

Volume [dm³] 9 to 15

Materials PP, PVDF, stainless steel, titanium

Filter elements (optionally) Wound cartridge
Membrane cartridge
Cloth cartridge
Filter paper
Filter bag
Active carbon

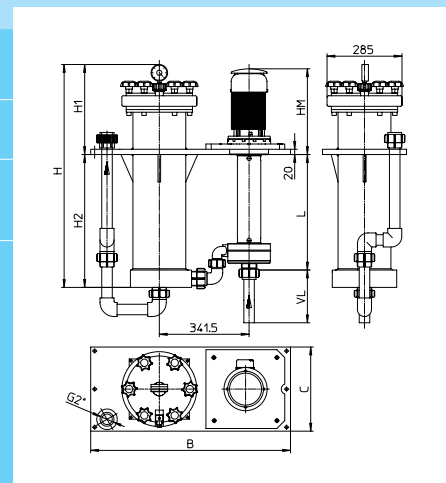

Vertical centrifugal immersion pump RT1 to RT5, combined with quick-change filter housing SF1 or SF3



Series RT-SF has proved to be especially successful when used in chemical plants. These filters are characterised by a compact design and by simple and quick handling by means of a quick-action closure, thereby enabling maintenance times to be greatly reduced. Two different filter sizes with many different filter elements are available for combination with our vertical centrifugal immersion pumps.

Quick-change filters are fitted with two safety switches as standard. These prevent operation of the filter without the filter cover or with it open.

Special design

During the project planning phase (e.g. of electrolytic plants), Renner defines interfaces and works out the design of requested special features in close collaboration with the customer. The customer receives an individual, ready-to-install function module. The units are optimally configured to your particular application, and are delivered assembled and ready for operation.

Quick-change filter housing	
SF1	
Housing length [inch]	10" (1 x 10") 20" (2 x 10")
Volume [dm³]	2.37 to 4.25
Materials	PP PVDF
Filter elements (optionally)	Filter sieve Wound cartridge
SF3	
Housing length [inch]	10" (3 x 10") 20" (6 x 10")
Volume [dm³]	8.4 to 13.5
Materials	PP PVDF
Filter elements (optionally)	Wound cartridge Filter bag Active carbon

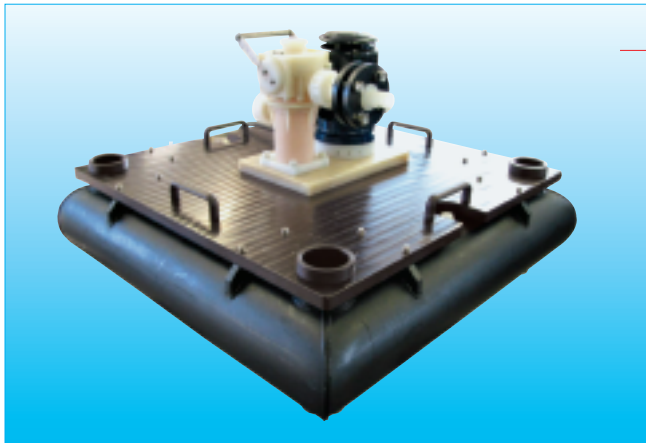

RT filter combination on floating pendant

PROCEDURE FOR PUMP CONFIGURATION AND CALCULATION OF THE PRESSURE LOSS

1. Dimensioning of the pipe inside diameter of the pressure line

To transport a particular flow rate, the necessary pipe cross section can be initially and approximately determined with the aid of the following formulae:

$$d_i = 18.8 \cdot \sqrt[3]{\frac{Q_1}{v}} \quad \text{or} \quad d_i = 4.6 \cdot \sqrt[3]{\frac{Q_2}{v}}$$

v	Flow velocity	[m/s]
d _i	Pipe inside diameter	[mm]
Q ₁	Flow rate	[m ³ /h]
Q ₂	Flow rate	[l/min]

Guideline value for the flow velocity of liquids in pressure lines:

$$v = 1 - 3 \text{ m/s}$$

2. Determining the hydraulic losses/pressure loss calculation

Flow in pipelines causes friction. This gives rise to energy losses that become noticeable when a pressure drop occurs. The following are decisive for the level of the losses:

- the length of the pipeline
- the pipe cross section
- the roughness of the pipe inner wall
- the number and geometry of shaped parts (fittings), valves and pipe connections
- the viscosity and density of the medium
- the type of flow (laminar or turbulent)

We recommend using tables, diagrams and/or software programmes in order to determine the pressure loss of the pipes. This greatly simplifies determining the pressure loss.

2.1 Determining the key hydraulic values

Reynolds' number (Re)

The Reynolds' number states the ratio of the inertia forces attacking the flow particles to the viscosity forces.

$$Re = \frac{v \cdot d_i}{10^3 \cdot \nu}$$

Re	Reynolds' number	[-]
d _i	Pipe inside diameter	[mm]
v	Flow velocity	[m/s]
ν	Kinematic viscosity	[m ² /s]

Pipe friction coefficient (λ)

The dimensional pipe friction coefficient is required in order to determine the hydraulic losses in the pipelines.

The following applies to laminar flows (Re < 2320):

$$\lambda = \frac{64}{Re}$$

λ	Pipe friction coefficient	[-]
Re	Reynolds' number	[-]

The pipe friction coefficient λ can be determined using the following equation for turbulent flows (Re > 2320) in hydraulically smooth pipes: The following applies to Re up to approx. 2·10⁶ and Re·k/d_i < 65:

$$\lambda = 0.0054 + \frac{0.4}{Re^{0.3}}$$

λ	Pipe friction coefficient	[-]
Re	Reynolds' number	[-]
k	Roughness value	[mm]

Assumption for k: k = 0.007 (for seamlessly extruded pipes made of thermoplastics)

2.2 Pressure losses in straight pipe sections

Note: The pressure loss in a pipe section is inversely proportional to the pipe diameter and increases with the pipeline length.

$$\Delta p_{\text{Pipe}} = \lambda \cdot \frac{L}{d_i} \cdot \frac{\rho}{2 \cdot 10^2} \cdot v^2$$

Δp _{Pipe}	Pressure loss of the straight pipe section	[bar]
λ	Pipe friction coefficient	[-]
L	Length of the straight pipe section	[m]
v	Flow velocity	[m/s]
ρ	Density of the pumped medium	[kg/m ³]
d _i	Pipe inside diameter	[mm]

2.3 Pressure losses in shaped pipe pieces (fittings)

The pressure losses depend on the fitting type and on the flow pattern in the fitting. The so-called ζ value serves as the calculation variable. The table below shows the hydraulic resistance coefficients of the most important shaped pipe pieces.

Pipe outside diameter d in mm	20	32	50	63
Shaped part type	Resistance coefficient ζ			
90° elbow	1.5	1	0.6	0.5
90° Angle	2	1.7	1.1	0.8
45° Angle	0.3			
Tee	1.5			
Inflow	0.5			
Outflow	0.5			

The sum of all individual losses, i.e. the sum of all ζ values, must be determined for calculating the pressure loss of all fittings. The pressure loss can then be calculated directly with the following formula:

$$\Delta p_{\text{Fitting}} = \Sigma \zeta \cdot \frac{v^2}{2 \cdot 10^5} \cdot \rho$$

Δp _{Fitting}	Pressure loss of all fittings	[bar]
Σζ	Sum of all individual losses	
v	Flow velocity	[m/s]
ρ	Density of the pumped medium	[kg/m ³]

2.4 Pressure losses in valves

The so-called k_v values, and also the pressure loss diagrams, can be found in valve manufacturers' documents.

The pressure loss from the k_v values can be calculated as follows:

$$\Delta p_{\text{Valve}} = \left(\frac{Q}{k_v} \right)^2 \cdot \frac{\rho}{1000}$$

Δp_{Valve} Valve pressure loss [bar]
 Q Flow rate [m³/h]
 ρ Density of the pumped medium [kg/m³]
 k_v Valve characteristic value [m³/h]

2.5 Sum of all pressure losses

The sum of all pipeline pressure losses is then obtained from:

$$\Sigma \Delta p = p_{\text{Pipe}} + p_{\text{Fitting}} + p_{\text{Valve}}$$

p_{Valve} Valve pressure loss [bar]
 p_{Fitting} Pressure loss of all fittings [bar]
 p_{Pipe} Pressure loss in the straight pipe sections [bar]
 p_{Connect} Pressure loss at the connecting points [bar]

Depending on the number and design quality of the pipe connections, it is recommended for pressure losses of connections p_{Connect} to include in the calculations an extra 3 – 10 % on top of the previously determined total pressure loss $\Sigma \Delta p$.

3. Determining the required pump delivery head

In order to determine the delivery head of the pump, the geodetic height difference in bar must be added to the flow losses as follows.

$$\Delta p_{\text{geod}} = \frac{H_{\text{geod}} \cdot \rho}{10^4}$$

Δp_{geod} Geodetic pressure difference [bar]
 H_{geod} Geodetic height [m]
 ρ Density of the pumped medium [kg/m³]

Arithmetically determined pump delivery head

$$\Delta p_{\text{Pump}} = \Sigma \Delta p + \Delta p_{\text{geod}}$$

Δp_{Pump} Required pump pressure [bar]
 Δp_{geod} Geodetic pressure difference [bar]
 $\Sigma \Delta p$ Total pressure loss of the pipeline [bar]

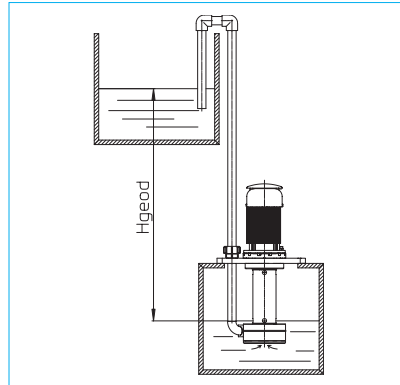

4. Influence of the density on the motor power

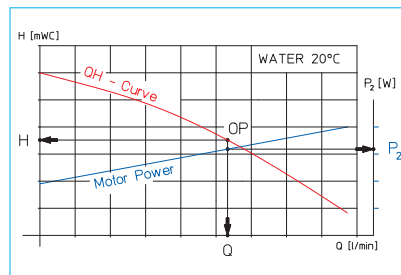

Read-off example: The motor power P_2 required for the desired operating point OP at a density of 1.0 (water) is read off from the characteristics diagram of the corresponding pump.

To obtain the pump motor power required for the desired application, the density of the pumping medium ρ_{Medium} must be multiplied by the motor power P_2 determined from the diagram.

$$P_{\text{Motor}} = P_2 \cdot \frac{\rho_{\text{Medium}} (\vartheta)}{\rho_{\text{Water}} (20^\circ \text{C})}$$

P_{Motor} Required drive power of the pump at density ρ_{Medium} [kW]
 P_2 Required drive power of the pump at density ρ_{Water} [kW]
 ρ_{Water} Water density [kg/m³]
 ρ_{Medium} Medium density [kg/m³]

Conversion tables

Flow rate $Q = \dot{V}$

	l/s	l/min	l/h	m ³ /h	US GPM	IMP GPM
1 l/s =	1	60	3600	3.6	15.85	13.20
1 l/min =	0.01667	1	60	0.06	0.2642	0.2200
1 l/h =	0.000278	0.01667	1	0.001	0.00440	0.00367
1 m ³ /h =	0.278	16.67	1000	1	4.40	3.67
1 US GPM =	0.06308	3.785	227.10	0.227	1	0.833
1 IMP GPM =	0.07577	4.546	272.76	0.273	1.201	1

Pressure p

	bar	Pa=N/m ²	PSI	mWC	kp/cm ² =atü	atm
1 bar =	1	10 ⁵	14.504	10.20	1.02	0.987
1 Pa = 1 N/m ² =	10 ⁻⁵	1	1.45×10 ⁻⁴	0.197×10 ⁻⁴	0.102×10 ⁻⁵	9.87×10 ⁻⁶
1 PSI =	0.0689	6894.8	1	0.7031	0.0703	0.068
1 mWC =	0.0981	9810	1.422	1	0.1	0.0968
1 kp/cm ² = 1 atü =	0.981	98100	14.22	10	1	0.968
1 atm =	1.013	101325	14.70	10.33	1.033	1

Power P

	W = J/s	kW = kJ/s	HP	PS
1 W =	1	1×10 ⁻³	1.341×10 ⁻³	1.36×10 ⁻³
1 kW =	1000	1	1.341	1.36
1 HP =	745.7	0.7457	1	0.986
1 PS =	736	0.736	1.014	1

Dynamic viscosity η

	Poise = g/cm·s	Reyn = lb·sec/in ²	Pa·s = kg/m·s
1 Poise =	1	1.45 × 10 ⁻⁵	0.1
1 Reyn =	68948	1	6894.8
1 Pa·s =	10	1.45 × 10 ⁻⁴	1

Kinematic viscosity $\nu = \frac{\eta}{\rho}$

	Stokes	m ² /s	in ² /s	ft ² /s
1 cm ² /s = 1 Stokes =	1	10 ⁻⁴	0.155	0.00108
1 m ² /s =	10 ⁴	1	1550	10.76
1 in ² /s =	6.452	6.452 × 10 ⁻⁴	1	0.06944
1 ft ² /s =	929.03	0.09290	144	1

QUESTIONNAIRE FOR SELECTING VERTICAL CENTRIFUGAL IMMERSION PUMPS

1. What type of pump is required? (see drawing on Page 10)

- Vertical centrifugal immersion pump **RT**
 Vertical centrifugal immersion pump **RT-A** (dry set-up outside the tank)
 Vertical centrifugal immersion pump with magnetic coupling **RT-M**
 Vertical centrifugal immersion pump with intermediate bearing **RT-Z**

2. What medium is to be pumped?

- 2.1 Designation: _____ Chem. formula: _____
 2.2 Concentration: _____ [%]
 2.3 Density: _____ [kg/dm³]
 2.4 kinem. viscosity: _____ [mm²/s]
 2.5 Operating temperature: Min. _____ [°C] Max. _____ [°C]
 2.6 Does the medium contain solids: yes no
 (If yes, please provide overleaf the most precise details possible, such as solids content, grain size, hardness, blunt or sharp-edged, abrasive)
 2.7 Is a filter also required for the process? yes no
 2.8 Based on experience to date, which active agents are chemically resistant to the pumped medium?
 PP PVDF 1.4571 NBR EPDM FKM
 others _____

3. What pumping capacity should the pump have?

- 3.1 Delivery rate: _____ [l/min] _____ [m³/h]
 3.2 Total delivery head: _____ [mWC]
 3.4 Immersion depth [L]: _____ [mm]

4. Operating conditions

- 4.1 Daily operating time: _____ [h]
 4.2 Daily switch-on frequency: _____ [h]
 4.3 Ambient temperature Min. _____ [°C] Max. _____ [°C]
 4.4 Installation outdoors yes no
 4.5 Medium tends toward crystal formation no slightly heavily

5. Electric motor

- 5.1 Voltage: _____ [V] 1-phase 3-phase
 5.2 Frequency: _____ [Hz]
 5.3 Speed: _____ [1/min]
 5.4 Protection type: _____
 5.5 Frequency converter operation yes no integrated in the motor

6. Connections

- 6.1 Thread conforming to DIN 8063 Flange conforming to DIN 2501
 6.2 **Suction side:** d _____ DN _____ G _____"
 6.3 **Pressure side:** d _____ DN _____ G _____"
 6.4 **Extension pipe [VL]** _____ mm

7. Additional details

Plant: _____ Installation drawing



INNOVATIVE PUMP
AND FILTER TECHNOLOGY



Flux Pumps Corporation

4330 Commerce Circle
Atlanta, GA 30336
Phone # 800-367-3589
Fax # 404-691-6314
mikef@flux-pumps.com
www.flux-renner.com
www.renner-pumpen.de