



AIR-OPERATED
DIAPHRAGM PUMPS
TYPE RFM AND RFML

INNOVATORS
IN FLOW TECHNOLOGY

REKO-FLUX AIR-OPERATED DIAPHRAGM PUMPS TYPE RFM AND RFML OF SOLID CONSTRUCTION



REKO-FLUX air-operated diaphragm pumps are most versatile and can be used for almost every liquid in all different fields of industry.

Be it viscous products, even with solids in suspension, abrasive fluids, high flammability or aerated liquids: REKO-FLUX air-operated diaphragm pumps meet every application featuring high operation safety and reliability.

Due to their solid construction together with matched diaphragms, these self-priming pumps are especially designed for continuous operation. REKO-FLUX air-operated diaphragm pumps ensure a very smooth liquid transfer (no shearing), are insensitive to solids in suspension, safe in dry running as well as totally overload-proof.

Other main features of REKO-FLUX air-operated diaphragm pumps are their high cost efficiency and a very low noise level. Each pump can be easily dismantled for an optimum cleaning. A comprehensive range of accessories such as pulsation dampers, pressure controllers with filter unit, stroke counters and fittings guarantee a safe use of the pumps.

Features and benefits:

- solid pump design due to massive type of construction
- five model sizes up to 2"
- max. delivery rates of 30 to 385 l/min
- pump housing in PP or PTFE
- models up to 1" also available in conductive version Type RFML for use in hazardous areas according to Directive 94/9/EC - ATEX 100a – PTB Registration No. 04 ATEX D102 
- explosion-proof to II 2 G cp IIB X
- vulcanized diaphragms including a metallic core
- no diaphragm discs
- safe dry running and overload-proof
- self-priming
- insensitive to solids in suspension
- very smooth liquid transfer
- variable delivery rates by simply adjusting the air pressure
- no rotating parts, no shaft seals
- very low noise level
- very high chemical resistance
- suitable for high temperatures
- high service life due to short stroke lifts
- easily accessible control valve without seals
- **comprehensive range of accessories:**
 - pressure controller with filter unit
 - stroke counter
 - pulsation damper

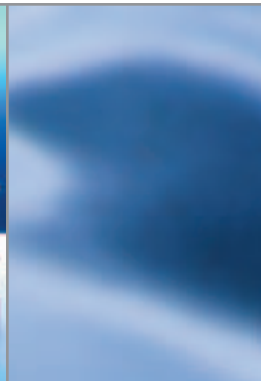

Which material goes best with which liquid	4
Function and construction features	5
Air-operated diaphragm pumps size $\frac{3}{8}$ " Type RFM 10 Type RFML 10 electrically conductive	6 – 7
Air-operated diaphragm pumps size $\frac{1}{2}$ " Type RFM 15 Type RFML 15 electrically conductive	8 – 9
Air-operated diaphragm pumps size 1" Type RFM 25 Type RFML 25 electrically conductive	10 – 11
Air-operated diaphragm pumps size 1 $\frac{1}{2}$ " Type RFM 40	12
Air-operated diaphragm pumps size 2" Type RFM 50	13
Dimensions of air-operated diaphragm pumps Type RFM and RFML	14 – 15
Accessories and fittings	16 – 18
The great range of FLUX pumps	19

WHICH MATERIAL GOES BEST WITH WHICH LIQUID

MATERIAL PUMP HOUSING

Polypropylene (PP) up to 60 °C

suitable for corrosive liquids, acids and alkalis,
as well as neutral liquids

Polypropylene conductive (PP) up to 60 °C

suitable for high flammability liquids

Polytetrafluorethylene (PTFE) up to 100 °C

suitable for very corrosive liquids, concentrated acids
and alkalis, as well as neutral liquids

Polytetrafluorethylene conductive (PTFE) up to 100 °C

suitable for high flammability liquids

MATERIAL DIAPHRAGM, BALLS AND SEALS

NBR (NN) up to 90 °C

Acrylonitrile-Butadiene-Rubber

EPDM (EE) up to 80 °C

Ethylene-Propylene-Diene-Rubber

FKM (VV) up to 90 °C

Fluor-Rubber

PTFE (TT) up to 100 °C

Polytetrafluorethylene

For more information about the chemical resistance of each material, please ask for the detailed
FLUX Resistance Chart.

EXAMPLE OF TYPE CODE

RFM 25 PP/NN

RFM 25 PP/NN = model size

RFM 25 PP/NN = material pump housing

RFM 25 PP/NN = material diaphragm, balls and seals

FUNCTION FEATURES IN DETAIL

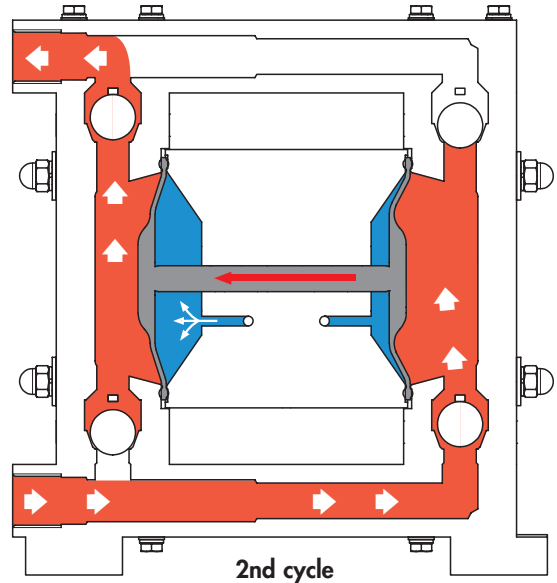
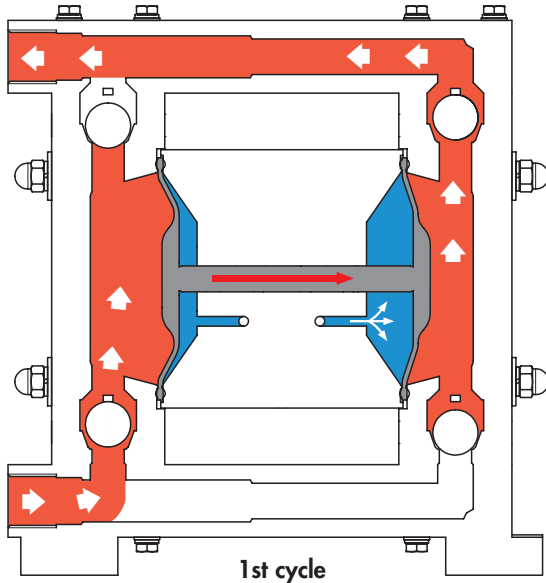

REKO-FLUX air-operated diaphragm pumps are positive displacement pumps consisting of two pump housings and one control valve part. Diaphragms within the pump housings securely separate the liquid section (red) from the air section (blue). Both diaphragms are connected by a selector shaft which is located in the control valve part.

Compressed air inflating alternately the air sections causes a movement of the diaphragms (1st and 2nd cycle). The subsequent transfer operation is controlled by a control valve which is easy to dismantle. Due to their solid construction, the pumps are designed for continuous operation and do not require any special maintenance.

CONSTRUCTION FEATURES IN DETAIL

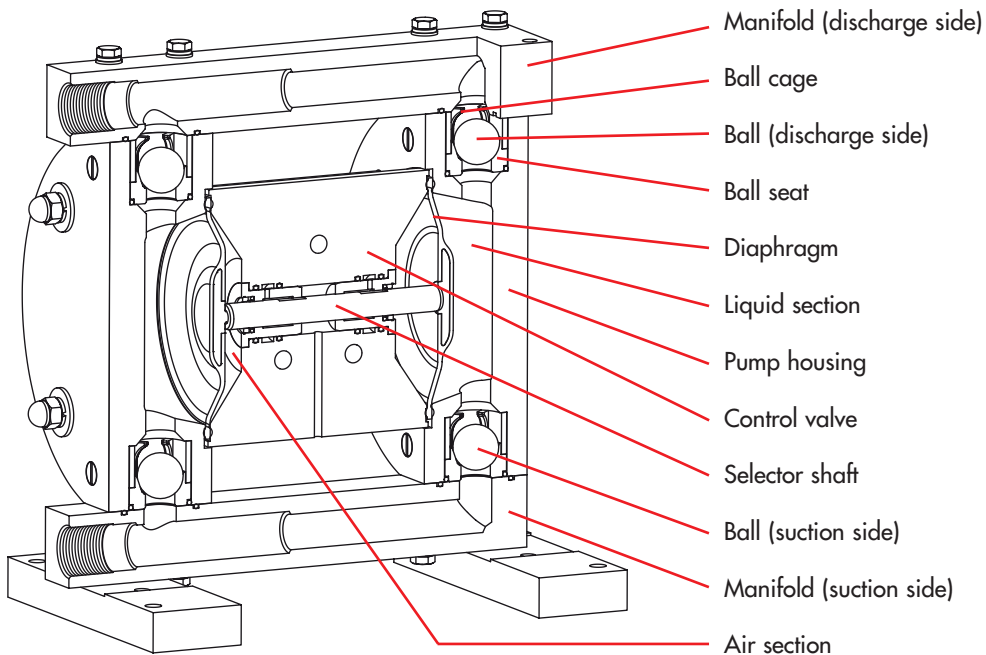

REKO-FLUX AIR-OPERATED DIAPHRAGM PUMP TYPE RFM 10 IN POLYPROPYLENE (PP) OR POLYTETRAFLUORETHYLENE (PTFE), 3/8"



TECHNICAL DATA

Delivery rate max.	30 l/min
Operating pressure max.	7 bar
Suction head, dry	up to 2-3 m
Suction head, liquid-filled	up to 8 m
Max. size of solids	4 mm
Connection pump	
suction side	G 3/8 (BSP 3/8" female)
discharge side	G 3/8 (BSP 3/8" female)
Connection air	
inlet	G 1/8 (BSP 1/8" female)
outlet*	G 1/8 (BSP 1/8" female)

*with silencer

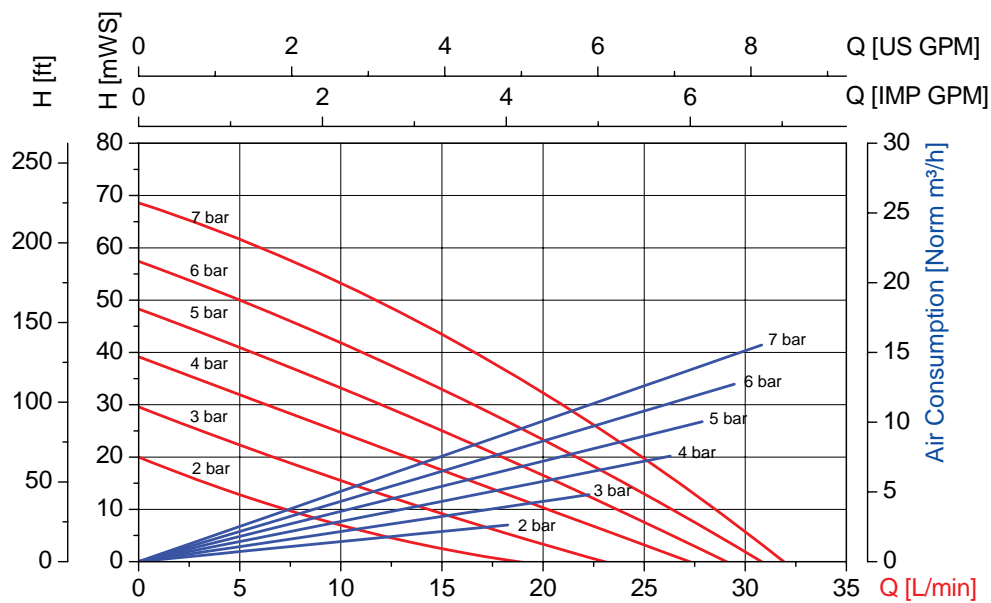

Type / Material	Pump housing	Diaphragm/ Ball	Seal	Weight	Part No.
RFM 10 PP/NN	PP	NBR	NBR	3,0 kg	D10 40 010
RFM 10 PP/TT	PP	PTFE	PTFE	3,0 kg	D10 40 110
RFM 10 PP/EE	PP	EPDM	EPDM	3,0 kg	D10 40 210
RFM 10 PP/VV	PP	FKM	FKM	3,0 kg	D10 40 310
RFM 10 PTFE/TT	PTFE	PTFE	PTFE	5,0 kg	D10 00 110
RFM 10 PTFE/EE	PTFE	EPDM	EPDM	5,0 kg	D10 00 210
RFM 10 PTFE/VV	PTFE	FKM	FKM	5,0 kg	D10 00 310

REKO-FLUX AIR-OPERATED DIAPHRAGM PUMP TYPE RFML 10 IN POLYPROPYLENE (PP) OR POLYTETRAFLUORETHYLENE (PTFE), 3/8"

ELECTRICALLY CONDUCTIVE FOR USE IN HAZARDOUS AREAS ACCORDING TO DIRECTIVE 94/9/EC-ATEX100a



TECHNICAL DATA

Delivery rate max.	30 l/min
Operating pressure max.	7 bar
Suction head, dry	up to 2-3 m
Suction head, liquid-filled	up to 8 m
Max. size of solids	4 mm
Explosion-proof to	Ex II 2 G cp IIB X
PTB Registration No.	04 ATEX D102
Connection pump	
suction side	G 3/8 (BSP 3/8" female)
discharge side	G 3/8 (BSP 3/8" female)
Connection air	
inlet	G 1/8 (BSP 1/8" female)
outlet*	G 1/8 (BSP 1/8" female)

*with silencer

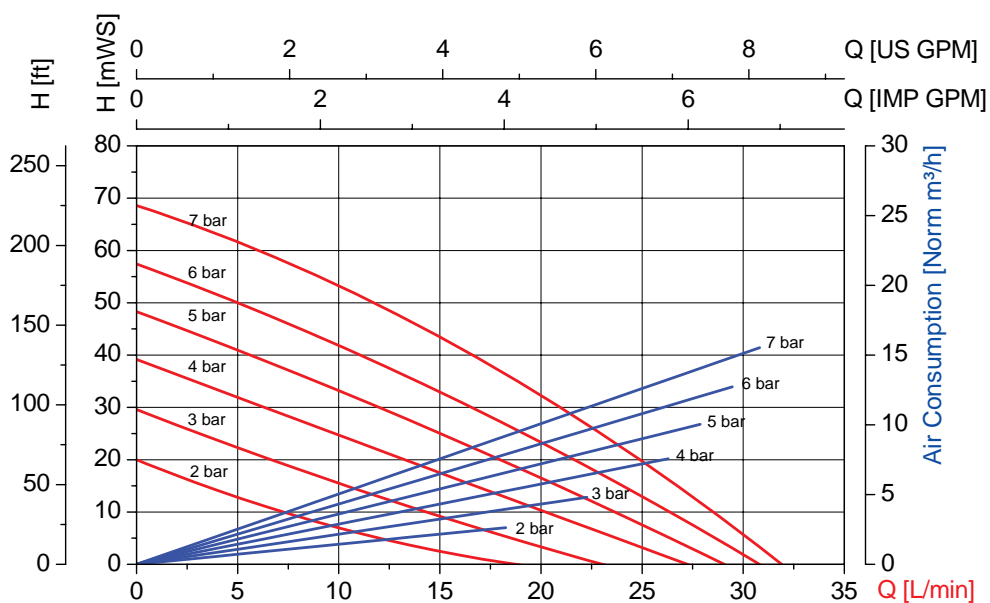

Values ± 10% with water at 20 °C

Type / Material	Pump housing	Diaphragm/ Ball	Seal	Weight	Part No.
RFML 10 PP/NN	PP conductive	NBR	NBR	3,0 kg	D10 41 010
RFML 10 PP/TT	PP conductive	PTFE	PTFE	3,0 kg	D10 41 110
RFML 10 PP/EE	PP conductive	EPDM	EPDM	3,0 kg	D10 41 210
RFML 10 PP/VV	PP conductive	FKM	FKM	3,0 kg	D10 41 310
RFML 10 PTFE/TT	PTFE conductive	PTFE	PTFE	5,0 kg	D10 01 110
RFML 10 PTFE/EE	PTFE conductive	EPDM	EPDM	5,0 kg	D10 01 210
RFML 10 PTFE/VV	PTFE conductive	FKM	FKM	5,0 kg	D10 01 310

REKO-FLUX AIR-OPERATED DIAPHRAGM PUMP TYPE RFM 15 IN POLYPROPYLENE (PP) OR POLYTETRAFLUORETHYLENE (PTFE), 1/2"



TECHNICAL DATA

Delivery rate max.	55 l/min
Operating pressure max.	7 bar
Suction head, dry	up to 3 m
Suction head, liquid-filled	up to 8 m
Max. size of solids	4 mm
Connection pump	
suction side	G 1/2 (BSP 1/2" female)
discharge side	G 1/2 (BSP 1/2" female)
Connection air	
inlet	G 1/4 (BSP 1/4" female)
outlet*	G 1/4 (BSP 1/4" female)

*with silencer

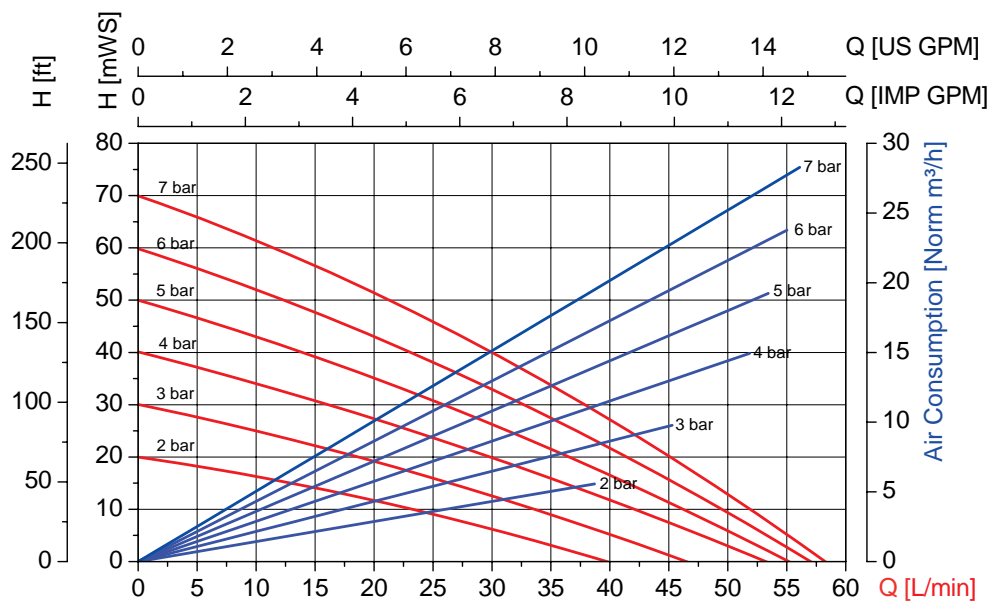

Values ± 10% with water at 20 °C

Type / Material	Pump housing	Diaphragm/ Ball	Seal	Weight	Part No.
RFM 15 PP/NN	PP	NBR	NBR	5,0 kg	D15 40 010
RFM 15 PP/TT	PP	PTFE	PTFE	5,0 kg	D15 40 110
RFM 15 PP/EE	PP	EPDM	EPDM	5,0 kg	D15 40 210
RFM 15 PP/VV	PP	FKM	FKM	5,0 kg	D15 40 310
RFM 15 PTFE/TT	PTFE	PTFE	PTFE	10,0 kg	D15 00 110
RFM 15 PTFE/EE	PTFE	EPDM	EPDM	10,0 kg	D15 00 210
RFM 15 PTFE/VV	PTFE	FKM	FKM	10,0 kg	D15 00 310

REKO-FLUX AIR-OPERATED DIAPHRAGM PUMP TYPE RFML 15 IN POLYPROPYLENE (PP) OR POLYTETRAFLUORETHYLENE (PTFE), 1/2"

ELECTRICALLY CONDUCTIVE FOR USE IN HAZARDOUS AREAS ACCORDING TO DIRECTIVE 94/9/EC-ATEX100a



TECHNICAL DATA

Delivery rate max.	55 l/min
Operating pressure max.	7 bar
Suction head, dry	up to 3 m
Suction head, liquid-filled	up to 8 m
Max. size of solids	4 mm
Explosion-proof to	Ex II 2 G cp IIB X
PTB Registration No.	04 ATEX D102

Connection pump

suction side	G 1/2 (BSP 1/2" female)
discharge side	G 1/2 (BSP 1/2" female)

Connection air

inlet	G 1/4 (BSP 1/4" female)
outlet*	G 1/4 (BSP 1/4" female)

*with silencer

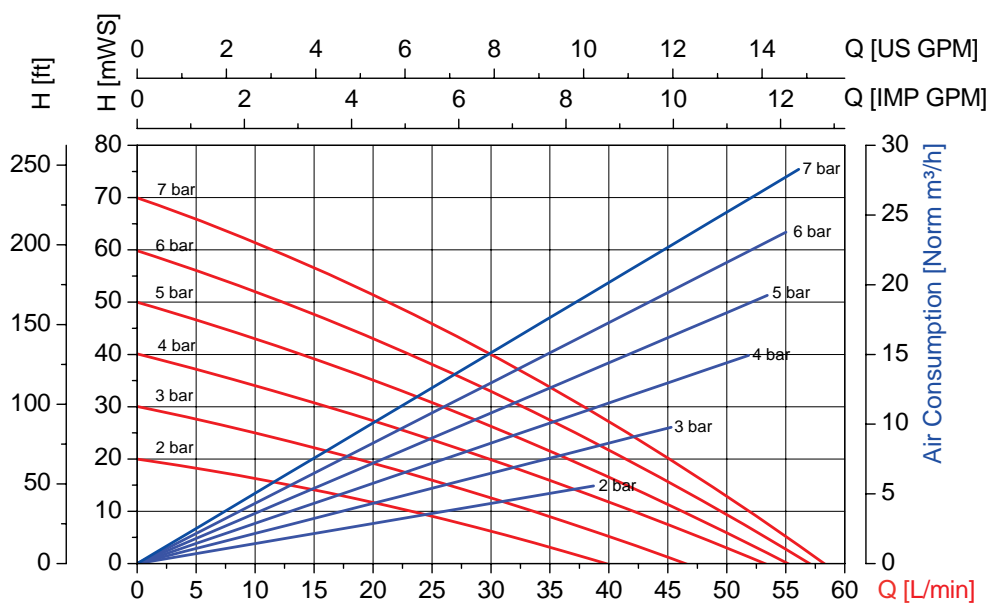

Values ± 10% with water at 20 °C

Type / Material	Pump housing	Diaphragm/ Ball	Seal	Weight	Part No.
RFML 15 PP/NN	PP conductive	NBR	NBR	5,0 kg	D15 41 010
RFML 15 PP/TT	PP conductive	PTFE	PTFE	5,0 kg	D15 41 110
RFML 15 PP/EE	PP conductive	EPDM	EPDM	5,0 kg	D15 41 210
RFML 15 PP/VV	PP conductive	FKM	FPM	5,0 kg	D15 41 310
RFML 15 PTFE/TT	PTFE conductive	PTFE	PTFE	10,0 kg	D15 01 110
RFML 15 PTFE/EE	PTFE conductive	EPDM	EPDM	10,0 kg	D15 01 210
RFML 15 PTFE/VV	PTFE conductive	FKM	FPM	10,0 kg	D15 01 310

REKO-FLUX AIR-OPERATED DIAPHRAGM PUMP TYPE RFM 25 IN POLYPROPYLENE (PP) OR POLYTETRAFLUORETHYLENE (PTFE), 1"



TECHNICAL DATA

Delivery rate max.	110 l/min
Operating pressure max.	7 bar
Suction head, dry	up to 3 m
Suction head, liquid-filled	up to 8 m
Max. size of solids	6 mm
Connection pump	
suction side	G 1 (BSP 1" female)
discharge side	G 1 (BSP 1" female)
Connection air	
inlet	G 1/4 (BSP 1/4" female)
outlet*	G 1/4 (BSP 1/4" female)

*with silencer

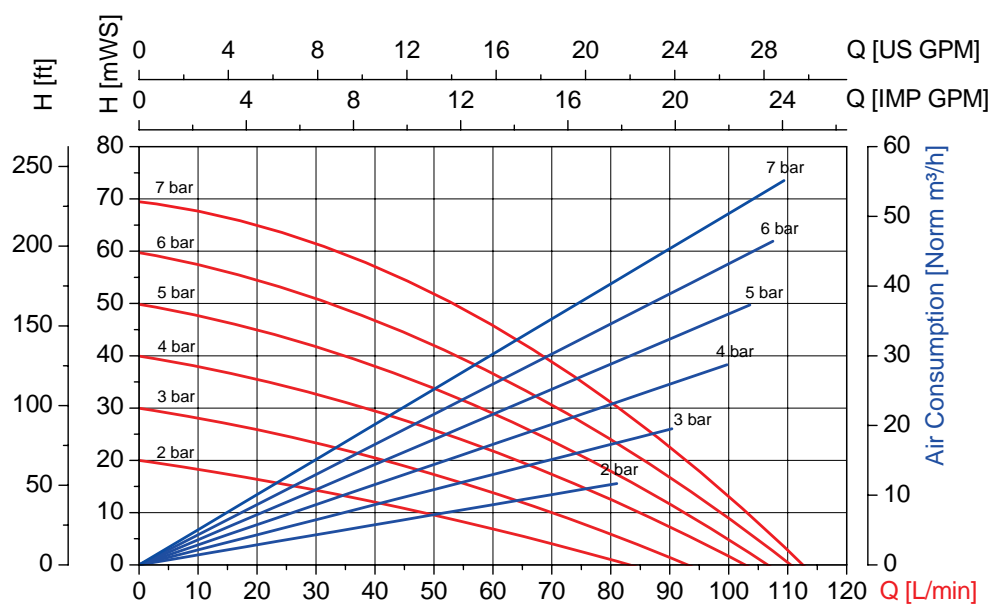

Type / Material	Pump housing	Diaphragm/ Ball	Seal	Weight	Part No.
RFM 25 PP/NN	PP	NBR	NBR	12,0 kg	D25 40 010
RFM 25 PP/TT	PP	PTFE	PTFE	12,0 kg	D25 40 110
RFM 25 PP/EE	PP	EPDM	EPDM	12,0 kg	D25 40 210
RFM 25 PP/VV	PP	FKM	FKM	12,0 kg	D25 40 310
RFM 25 PTFE/TT	PTFE	PTFE	PTFE	26,0 kg	D25 00 110
RFM 25 PTFE/EE	PTFE	EPDM	EPDM	26,0 kg	D25 00 210
RFM 25 PTFE/VV	PTFE	FKM	FKM	26,0 kg	D25 00 310

REKO-FLUX AIR-OPERATED DIAPHRAGM PUMP TYPE RFML 25 IN POLYPROPYLENE (PP) OR POLYTETRAFLUORETHYLENE (PTFE), 1"

ELECTRICALLY CONDUCTIVE FOR USE IN HAZARDOUS AREAS ACCORDING TO DIRECTIVE 94/9/EC-ATEX100a



TECHNICAL DATA

Delivery rate max.	110 l/min
Operating pressure max.	7 bar
Suction head, dry	up to 3 m
Suction head, liquid-filled	up to 8 m
Max. size of solids	6 mm
Explosion-proof to	Ex II 2 G cp IIB X
PTB Registration No.	04 ATEX D102

Connection pump

suction side	G 1 (BSP 1" female)
discharge side	G 1 (BSP 1" female)

Connection air

inlet	G 1/4 (BSP 1/4" female)
outlet*	G 1/4 (BSP 1/4" female)

*with silencer

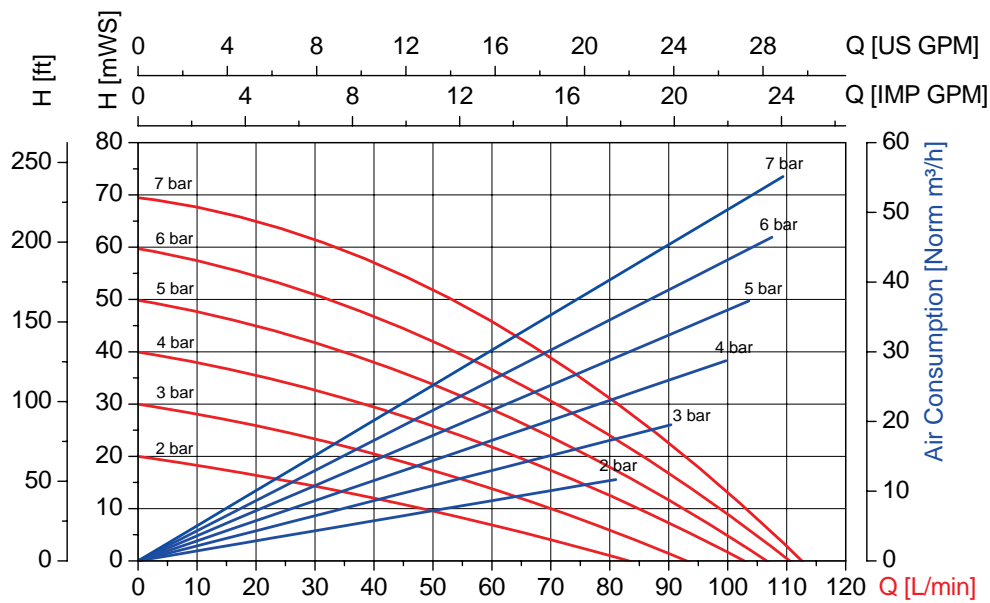

Values ± 10% with water at 20 °C

Type / Material	Pump housing	Diaphragm/ Ball	Seal	Weight	Part No.
RFML 25 PP/NN	PP conductive	NBR	NBR	12,0 kg	D25 41 010
RFML 25 PP/TT	PP conductive	PTFE	PTFE	12,0 kg	D25 41 110
RFML 25 PP/EE	PP conductive	EPDM	EPDM	12,0 kg	D25 41 210
RFML 25 PP/VV	PP conductive	FKM	FKM	12,0 kg	D25 41 310
RFML 25 PTFE/TT	PTFE conductive	PTFE	PTFE	26,0 kg	D25 01 110
RFML 25 PTFE/EE	PTFE conductive	EPDM	EPDM	26,0 kg	D25 01 210
RFML 25 PTFE/VV	PTFE conductive	FKM	FKM	26,0 kg	D25 01 310

REKO-FLUX AIR-OPERATED DIAPHRAGM PUMP TYPE RFM 40 IN POLYPROPYLENE (PP) OR POLYTETRAFLUORETHYLENE (PTFE), 1 1/2"



TECHNICAL DATA

Delivery rate max.	235 l/min
Operating pressure max.	7 bar
Suction head, dry	up to 4,5 m
Suction head, liquid-filled	up to 8 m
Max. size of solids	8 mm
Connection pump	
suction side	G 1 1/2 (BSP 1 1/2" female)
discharge side	G 1 1/2 (BSP 1 1/2" female)
Connection air	
inlet	G 1/2 (BSP 1/2" female)
outlet*	G 1/2 (BSP 1/2" female)

*with silencer

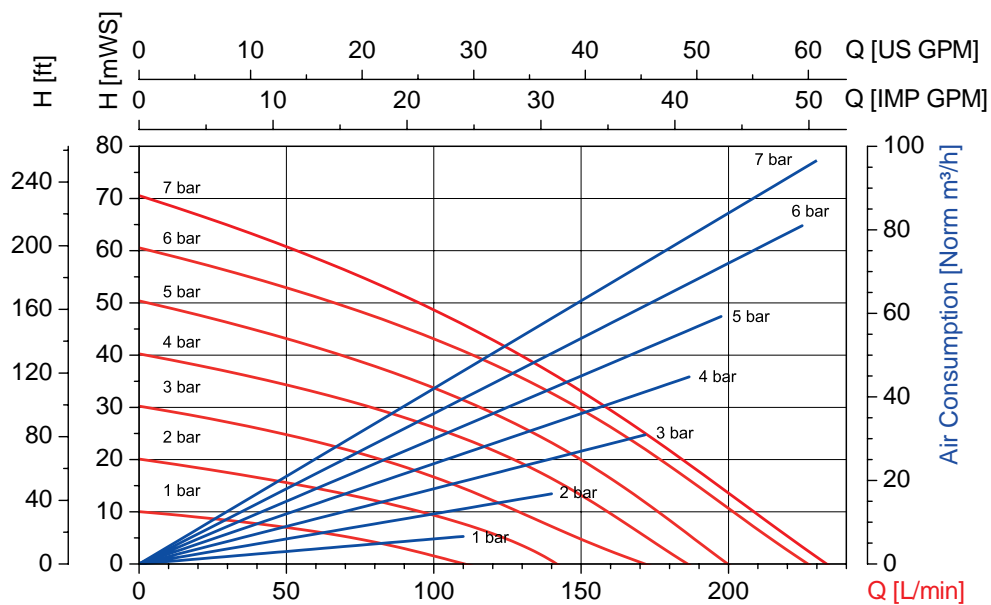

Values ± 10% with water at 20 °C

Type / Material	Pump housing	Diaphragm/ Ball	Seal	Weight	Part No.
RFM 40 PP/NN	PP	NBR	NBR	34,0 kg	D40 40 000
RFM 40 PP/TT	PP	PTFE	PTFE	34,0 kg	D40 40 100
RFM 40 PP/EE	PP	EPDM	EPDM	34,0 kg	D40 40 200
RFM 40 PP/VV	PP	FKM	FKM	34,0 kg	D40 40 300
RFM 40 PTFE/TT	PTFE	PTFE	PTFE	74,0 kg	D40 00 100
RFM 40 PTFE/EE	PTFE	EPDM	EPDM	74,0 kg	D40 00 200
RFM 40 PTFE/VV	PTFE	FKM	FKM	74,0 kg	D40 00 300

REKO-FLUX AIR-OPERATED DIAPHRAGM PUMP TYPE RFM 50 IN POLYPROPYLENE (PP) OR POLYTETRAFLUORETHYLENE (PTFE), 2"



TECHNICAL DATA

Delivery rate max.	385 l/min
Operating pressure max.	7 bar
Suction head, dry	up to 6 m
Suction head, liquid-filled	up to 8 m
Max. size of solids	8 mm
Connection pump	
suction side	G 2 (BSP 2" female)
discharge side	G 2 (BSP 2" female)
Connection air	
inlet	G 1/2 (BSP 1/2" female)
outlet*	G 1/2 (BSP 1/2" female)

*with silencer

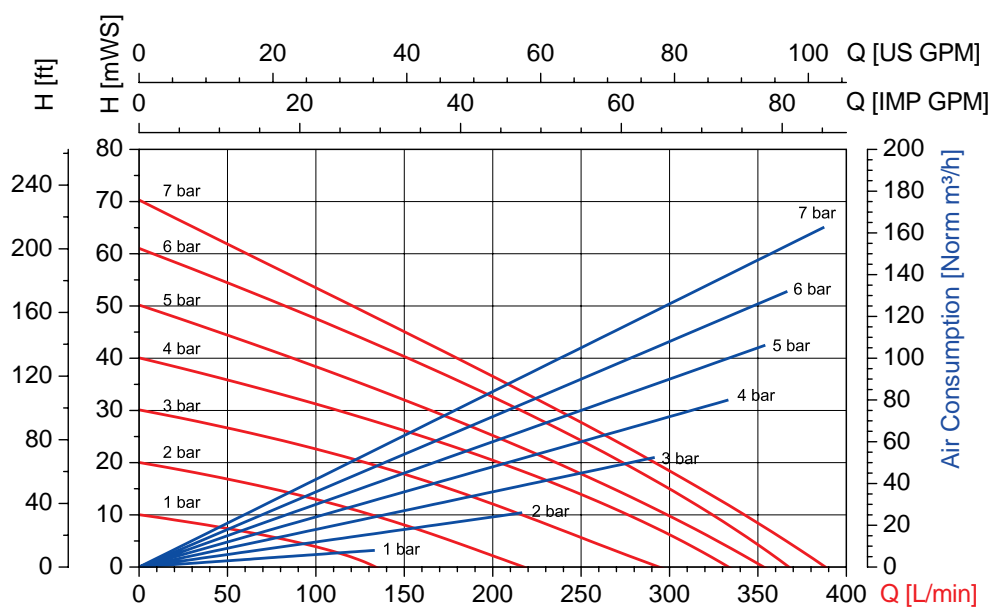

Values \pm 10% with water at 20 °C

Type / Material	Pump housing	Diaphragm/ Ball	Seal	Weight	Part No.
RFM 50 PP/NN	PP	NBR	NBR	52,0 kg	D50 40 000
RFM 50 PP/TT	PP	PTFE	PTFE	52,0 kg	D50 40 100
RFM 50 PP/EE	PP	EPDM	EPDM	52,0 kg	D50 40 200
RFM 50 PP/VV	PP	FKM	FKM	52,0 kg	D50 40 300
RFM 50 PTFE/TT	PTFE	PTFE	PTFE	108,0 kg	D50 00 100
RFM 50 PTFE/EE	PTFE	EPDM	EPDM	108,0 kg	D50 00 200
RFM 50 PTFE/VV	PTFE	FKM	FKM	108,0 kg	D50 00 300

DIMENSIONS

Type RFM 10 / RFML 10

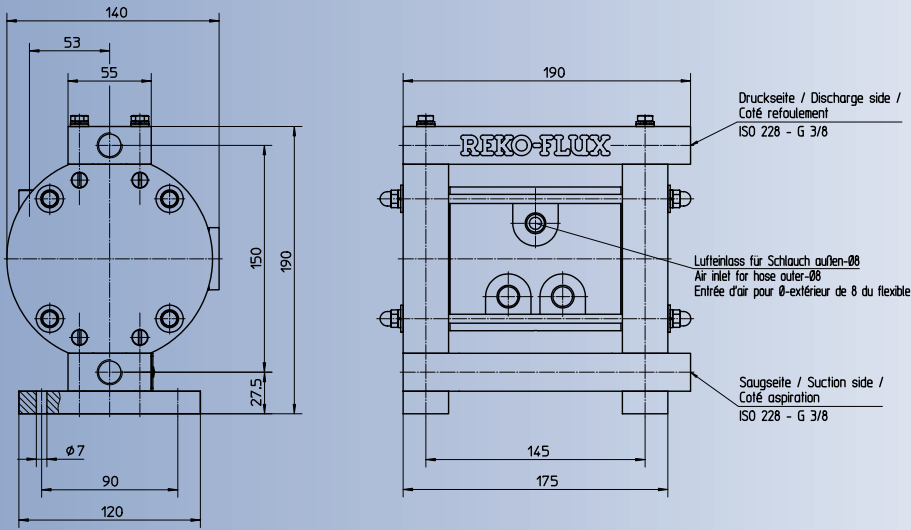

Type RFM 15 / RFML 15

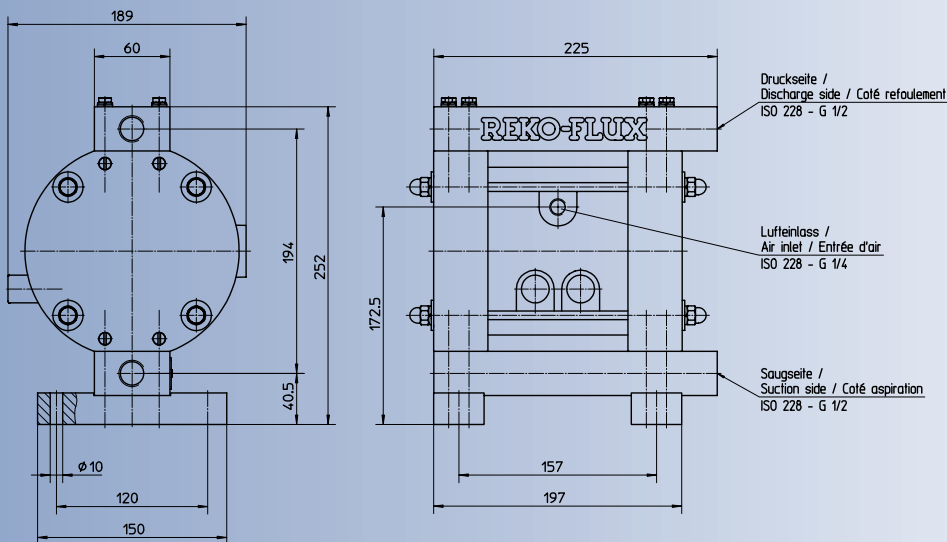

Type RFM 25 / RFML 25

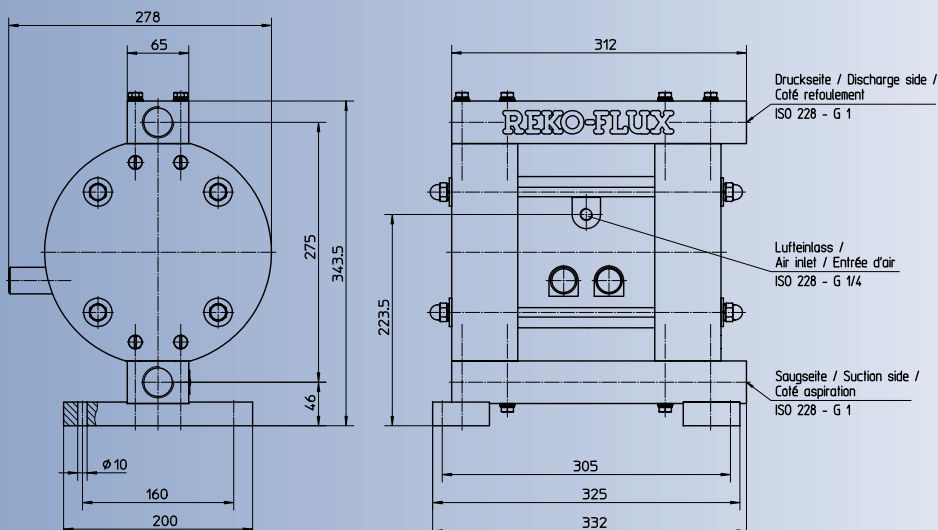

Type RFM 40

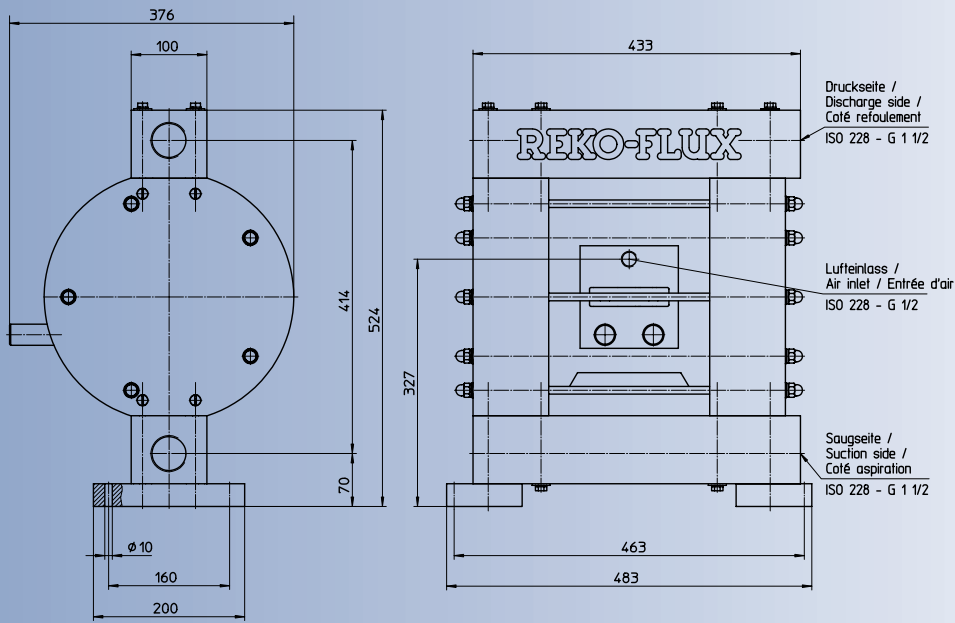

Type RFM 50

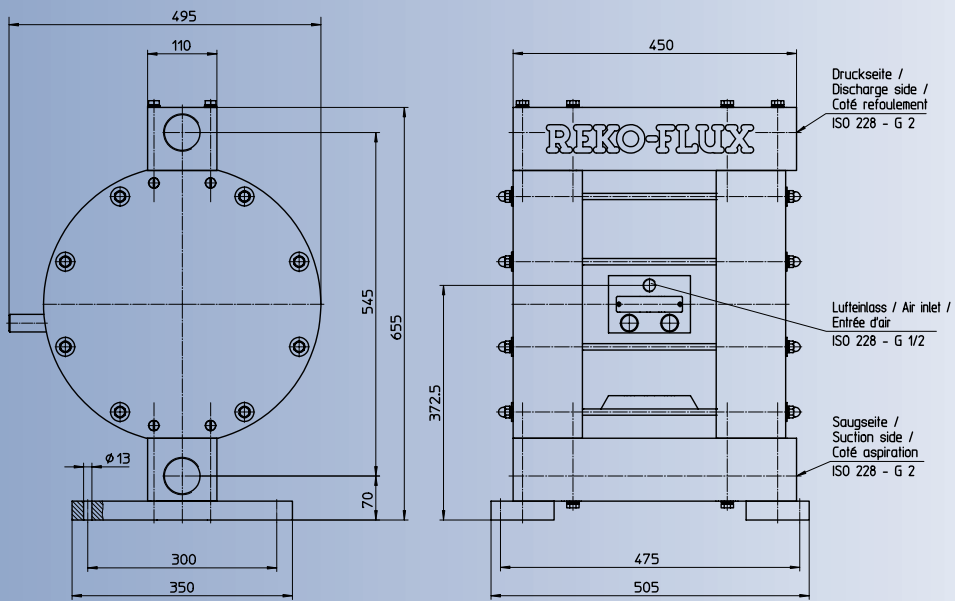

ACCESSORIES FOR REKO-FLUX AIR-OPERATED DIAPHRAGM PUMPS



PRESSURE CONTROLLER WITH FILTER AND SPEED REGULATOR,
MOUNTED ONTO PUMP

Pump Type	Connection	Part No./Weight
RFM 10	G 1/4 – G 3/8 (1/4"–3/8" female)	D01 00 410 /0,70 kg
RFM 15/25	G 1/4 – G 1/4 (1/4"–1/4" female)	D01 00 412 /0,72 kg
RFM 40	G 1/2 – G 1/2 (1/2"–1/2" female)	D01 00 403 /2,20 kg
RFM 50	G 1/2 – G 1/2 (1/2"–1/2" female)	D01 00 404 /2,30 kg

PRESSURE CONTROLLER WITH FILTER AND SPEED REGULATOR,
MOUNTED ONTO PUMP, VERSION FOR USE IN HAZARDOUS AREAS

Pump Type	Connection	Part No./Weight
RFML 10	G 1/4 – G 3/8 (1/4"–3/8" female)	D01 00 320 /0,96 kg
RFML 15/25	G 1/4 – G 1/4 (1/4"–1/4" female)	D01 00 322 /0,96 kg



PULSATION DAMPER, PASSIVE TYPE, MAX. OPERATING PRESSURE 8 BAR

Description	Diaphragm	Part No./Weight
PDP 15 PP/N	NBR	D01 15 400 /1,20 kg
PDP 15 PP/E	EPDM	D01 15 420 /1,20 kg
PDP 15 PP/V	FKM	D01 15 430 /1,20 kg
PDP 25 PP/N	NBR	D01 25 400 /2,00 kg
PDP 25 PP/E	EPDM	D01 25 420 /2,00 kg
PDP 25 PP/V	FKM	D01 25 430 /2,00 kg
PDP 40 PP/N	NBR	D01 40 400 /4,00 kg
PDP 40 PP/E	EPDM	D01 40 420 /4,00 kg
PDP 40 PP/V	FKM	D01 40 430 /4,00 kg
PDP 50 PP/N	NBR	D01 50 400 /14,0 kg
PDP 50 PP/E	EPDM	D01 50 420 /14,0 kg
PDP 50 PP/V	FKM	D01 50 430 /14,0 kg

Connection for filling end of pulsation damper

Version	Connection	Part No./Weight
Material: brass	G 1/4 - filling end	D01 00 000 /0,01 kg

STROKE COUNTER COMPLETE WITH 5/2-WAY VALVE

Pump Type	Part No./Weight
RFM 10/15	D01 00 101 /0,02 kg
RFM 25	D01 00 102 /0,02 kg
RFM 40/50	D01 00 103 /0,02 kg

Connecting cable, 5 m long

for use with digital display unit	934 08 038 /0,20 kg
for use with Process Control System PCS	934 08 030 /0,20 kg

External digital display unit

with mounting flange	001 42 008 /0,70 kg
----------------------	----------------------------



HOSE NIPPLE FOR DIRECT MOUNTING ONTO THE PUMP



Pump Type	Material	Connection	Part No./Weight
RFM 10	PP	DN 10 – G 3/8 A (3/8" male)	959 05 265 /0,01 kg
	PVDF	DN 10 – G 3/8 A (3/8" male)	959 05 267 /0,01 kg
	PP	DN 13 – G 3/8 A (3/8" male)	959 05 266 /0,01 kg
	PVDF	DN 13 – G 3/8 A (3/8" male)	959 05 270 /0,01 kg
RFM 15	PP	DN 13 – G 1/2 A (1/2" male)	959 05 183 /0,01 kg
	PVDF	DN 13 – G 1/2 A (1/2" male)	959 05 271 /0,01 kg
	PP	DN 19 – G 1/2 A (1/2" male)	959 05 268 /0,01 kg
	PVDF	DN 19 – G 1/2 A (1/2" male)	959 05 272 /0,01 kg
RFM 25	PP	DN 19 – G 1 A (1" male)	959 05 269 /0,01 kg
	PVDF	DN 19 – G 1 A (1" male)	959 05 273 /0,01 kg
	PP	DN 25 – G 1 A (1" male)	959 05 192 /0,01 kg
	PVDF	DN 25 – G 1 A (1" male)	959 05 275 /0,01 kg

HOSE CONNECTION COMPLETE, CONSISTING OF:
HOSE CONNECTOR WITH UNION NUT AND SEAL,
MOUNTING ONTO THE PUMP VIA REDUCTION NIPPLE



Pump Type	Material	Connection	Part No./Weight
RFM 10/15	PP	DN 13 – G 1 (1" female)	959 04 073 /0,02 kg
	PVDF	DN 13 – G 1 (1" female)	959 04 071 /0,02 kg
	PP	DN 19 – G 1 (1" female)	959 04 074 /0,02 kg
	PVDF	DN 19 – G 1 (1" female)	959 04 072 /0,02 kg
RFM 25	PP	DN 25 – G 1 1/4 (1 1/4" female)	959 04 052 /0,03 kg
	PVDF	DN 25 – G 1 1/4 (1 1/4" female)	959 04 102 /0,03 kg
	PP	DN 32 – G 1 1/4 (1 1/4" female)	959 04 054 /0,03 kg
	PVDF	DN 32 – G 1 1/4 (1 1/4" female)	959 04 103 /0,05 kg
RFM 40/50	PP	DN 32 – G 2 (2" female)	959 04 010 /0,05 kg
	PVDF	DN 32 – G 2 (2" female)	959 04 084 /0,05 kg
	PP	DN 38 – G 2 (2" female)	959 04 011 /0,14 kg
	PVDF	DN 38 – G 2 (2" female)	959 04 085 /0,14 kg
	PP	DN 50 – G 2 (2" female)	959 04 012 /0,19 kg
	PVDF	DN 50 – G 2 (2" female)	959 04 086 /0,19 kg

REDUCTION NIPPLE FOR CONNECTING THE HOSE CONNECTION COMPLETE
ONTO THE PUMP

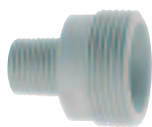

Pump Type	Material	Connection	Part No./Weight
RFM 10	PP	G 1 A – G 3/8 A (1" – 3/8" male)	959 06 159 /0,01 kg
	PVDF	G 1 A – G 3/8 A (1" – 3/8" male)	959 06 169 /0,01 kg
RFM 15	PP	G 1 A – G 1/2 A (1" – 1/2" male)	959 06 160 /0,01 kg
	PVDF	G 1 A – G 1/2 A (1" – 1/2" male)	959 06 170 /0,02 kg
RFM 25	PP	G 1 1/4 A – G 1 A (1 1/4" – 1" male)	959 06 161 /0,03 kg
	PVDF	G 1 1/4 A – G 1 A (1 1/4" – 1" male)	959 06 171 /0,03 kg
RFM 40	PP	G 2 A – G 1 1/2 A (2" – 1 1/2" male)	959 06 162 /0,03 kg
	PVDF	G 2 A – G 1 1/2 A (2" – 1 1/2" male)	959 06 172 /0,04 kg
RFM 50	PP	G 2 A – G 2 A (2" – 2" male)	959 06 163 /0,04 kg
	PVDF	G 2 A – G 2 A (2" – 2" male)	959 06 173 /0,04 kg

SUCTION TUBES FOR TYPE RFM 10, RFM 15 AND RFM 25, WITH THREAD CONNECTION G 3/4 A (3/4" MALE) ON BOTTOM END

Connection top end	Material	Immersion length	Ø	Part No./Gewicht
Hose nozzle DN 13	PP	700 mm	20 mm	959 18 020 /0,17 kg
		1000 mm		959 18 021 /0,17 kg
Hose nozzle DN 25	PP	700 mm	25 mm	959 18 008 /0,17 kg
		1000 mm		959 18 009 /0,17 kg
Male thread G 1 A	PP	700 mm	25 mm	959 18 010 /0,10 kg
		1000 mm		959 18 011 /0,10 kg
Male thread G 1 1/4 A	PP	700 mm	25 mm	959 18 012 /0,10 kg
		1000 mm		959 18 013 /0,10 kg

SUCTION STRAINERS FOR SUCTION TUBES

Connection	Material	Ø	Part No./Weight
Female thread G 1/2	PP	20 mm	001 10 335 /0,01 kg
Female thread G 3/4	PP	25 mm	001 10 324 /0,02 kg





YES!

I am interested in top class pump technology.
Please send the following catalogues:

- | | |
|---|---|
| <input type="checkbox"/> FLUX JUNIORFLUX | <input type="checkbox"/> FLUX CENTRIFUGAL IMMERSION PUMPS |
| <input type="checkbox"/> FLUX BARREL AND CONTAINER PUMPS | <input type="checkbox"/> FLUX LIQUID METERS |
| <input type="checkbox"/> FLUX PUMP KITS | <input type="checkbox"/> FLUX MIXERS |
| <input type="checkbox"/> FLUX HIGH VISCOSITY LIQUID PUMPS | <input type="checkbox"/> FLUX PROCESS CONTROL SYSTEM PCS |

Mr / Ms

Company

Address

Telephone

Fax

e-mail

Please mark with a cross, complete the address and then sent us a fax. Fax number see on the back side!

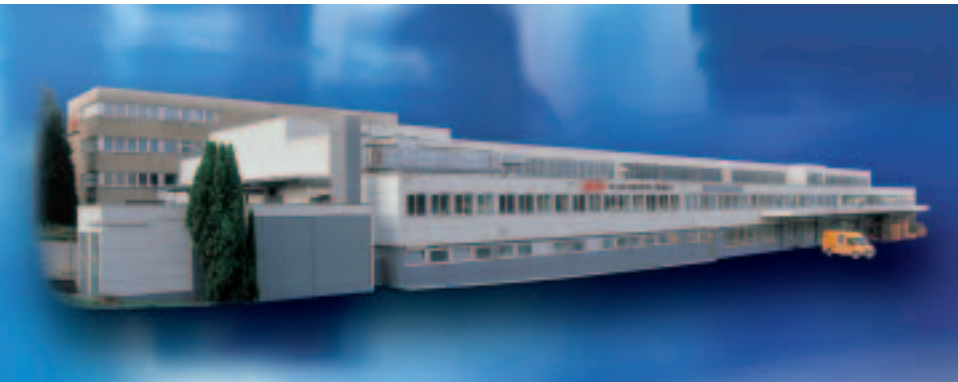

INNOVATORS IN FLOW TECHNOLOGY

All around the globe, FLUX is synonymous with top standards in pump technology. Whether it is barrel pumps, high viscosity liquid pumps, vertical centrifugal immersion pumps, air-operated diaphragm pumps, liquid meters, mixers or top class accessories – FLUX with its complete and comprehensive range is always the one to address to. Benefit from our competence. We look forward to hearing from you!

FLUX-GERÄTE GMBH
Talweg 12 · D-75433 Maulbronn
Tel. 070 43/101-0 · Fax 070 43/101-444
Fax International +49 70 43 / 1 01 -555
info@flux-pumpen.de · www.flux-pumpen.com