



Innovators in Flow Technology



JUNIORFLUX

Laboratory and
barrel pumps
for low volumes

JUNIORFLUX – The small Power Package



For filling, emptying, transferring or dispensing small amounts of liquids out of carboys, hobboscks, canisters, narrow-necked containers or barrels FLUX now offers a better performance: the new JUNIORFLUX pumps type F 310 and F 314.

The JUNIORFLUX pumps are available in polypropylene (PP), polyvinylidene fluoride (PVDF) or stainless steel (S), both in version with mechanical seal Type F 310 or sealless Type F 314.

A powerful 230 Watt commutator motor with a 2-speed switch allows sensitive, fast and therefore low-cost and safe filling operations. The motor is built to protection class II, splash-proof and comprises an overload cut-out switch. Another feature is the modern and ergonomically structured design for single-hand operation.

The JUNIORFLUX pump can be used in almost every field of industry. With a weight of 2 kg and being easy to handle, it may be used wherever small amounts of low flammability liquids, like acids, alkaline solutions, solvents, detergents, etc. must be decanted. Major fields of application are laboratories, chemical store rooms and workshops.

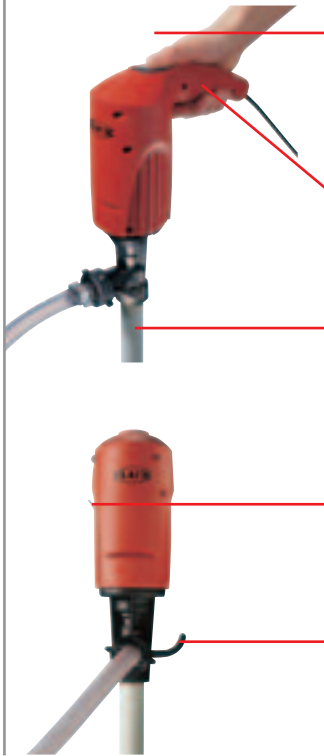

2-speed switch for control of delivery rate

ergonomic handle for single-hand operation

outer tube can be removed by hand

integral clip to suspend the pump

hook for fixing a hand tap

Special features and benefits:

- high safety factor: powerful 230 Watt motor with built-in overload cut-out switch, double insulated and splash-proof
- 2-speed switch for sensitive filling operations
- ergonomic handle
- version in 230 Volt tested to German VDE and GS specifications
- pumps with mechanical seal in polypropylene (PP) or sealless pumps in polypropylene (PP), polyvinylidene fluoride (PVDF) or stainless steel 316 Ti (S)
- easy cleaning: outer tube can be removed by hand
- integral clip to suspend the pump
- hook on pump outlet for fixing a hand tap



JUNIORFLUX F 310 PP, with mechanical seal	4 – 5
JUNIORFLUX F 314 PP, sealless	
JUNIORFLUX F 314 PVDF, sealless	
JUNIORFLUX F 314 S, sealless	
JUNIORFLUX pump kits and accessories	6
The Great Range of FLUX Pumps	7

Examples of liquids, the JUNIORFLUX pumps can be used for:

F 310 PP and F 314 PP: acetic acid up to 80%, ammonia water, boric acid, caustic soda, caustic potash solution, citric acid, formic acid, fruit acids, lactic acid, liquid fertilizers, liquid soap, phosphoric acid, distilled water.

For short periods: chlorine water, hydrochloric acid, hydrofluoric acid, sulphuric acid.

F 314 PVDF: chromic acid, nitric acid, sulphuric acid as well as all liquids listed under PP (except caustic soda).

F 314 S: acetic acid up to 80%, ammonia water, caprylic acid, caustic soda, caustic potash solution, fatty acids, lactic acid, methylene chloride, nitric acid up to 40%, perchloroethylene, trichloroethylene.

A detailed **Resistance Chart** on further liquids is available on request.

JUNIORFLUX F 310 and F 314



F 310
PP-25/19

Type/Curve	F 310 PP-25/19	F 314 PP-25/19	F 314 PVDF-25/19
Seal type	mechanical seal	sealless	sealless
Material (wetted parts)	Polypropylene, ETFE, ceramic oxide/PTFE/carbon, FKM, Hastelloy C	Polypropylene, ETFE, PTFE/carbon, Hastelloy C	Polyvinylidene fluoride, ETFE, PTFE/carbon, Hastelloy C
Outer-Ø	25 mm	25 mm	25 mm
Thread on outlet	G 1 A (BSP 1" male) Hose connections DN 13 and DN 19 included with the pump.		
Motor	Commutator motor 230 Watt, 240, 230 Volt, 50 Hz or 110 Volt, 50-60 Hz, double insulated, protection class II, splash-proof to IP 24, with overload cut-out switch, 2-speed switch, 5 m power supply cable with 2-pole plug		
Delivery rate max.	27 l/min	40 l/min	40 l/min
Delivery head max.	5,0 m	5,2 m	5,2 m
Viscosity max.	250 mPas (cP)	250 mPas (cP)	250 mPas (cP)
Temperature max.	45 °C	45 °C	60 °C
Part No. 230 Volt*/Weight			
Immersion length 500 mm	310 41 005/1,8 kg	314 41 005/1,8 kg	314 61 005/2,0 kg
Immersion length 700 mm	310 41 007/2,0 kg	314 41 007/2,0 kg	314 61 007/2,2 kg
Immersion length 1000 mm	310 41 010/2,1 kg	314 41 010/2,1 kg	314 61 010/2,4 kg
Part No. 240 Volt*/Weight			
Immersion length 500 mm	310 41 405/1,8 kg	314 41 405/1,8 kg	314 61 405/2,0 kg
Immersion length 700 mm	310 41 407/2,0 kg	314 41 407/2,0 kg	314 61 407/2,2 kg
Immersion length 1000 mm	310 41 410/2,1 kg	314 41 410/2,1 kg	314 61 410/2,4 kg
Part No. 110 Volt*/Weight			
Immersion length 500 mm	310 41 205/1,8 kg	314 41 205/1,8 kg	314 61 205/2,0 kg
Immersion length 700 mm	310 41 207/2,0 kg	314 41 207/2,0 kg	314 61 207/2,2 kg
Immersion length 1000 mm	310 41 210/2,1 kg	314 41 210/2,1 kg	314 61 210/2,4 kg

*tested to German VDE and GS specifications

Performance Chart

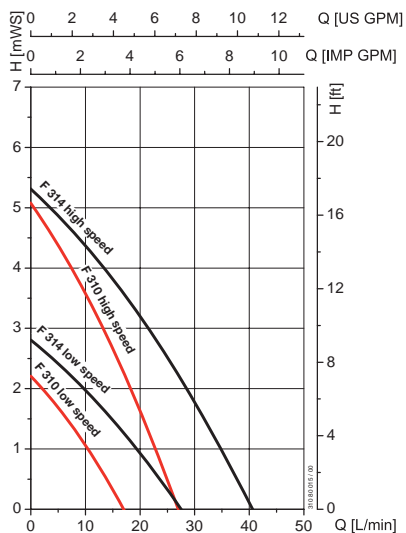

Dimensions F 310 PP-25/19 and F 314 PP/PVDF-25/19

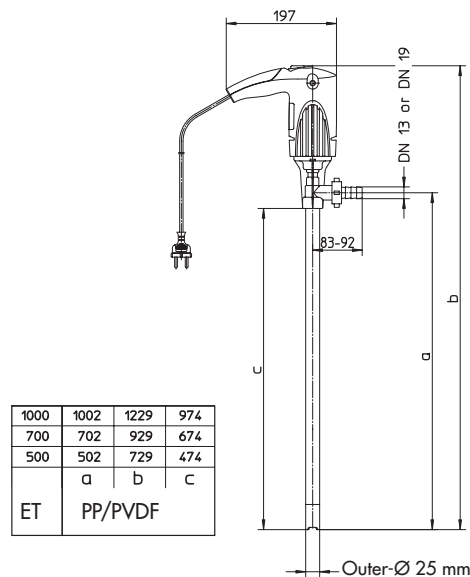



F 314
S-28/25

Type/Curve	F 310 PP-32/25	F 314 PP-32/25	F 314 S-28/25
Seal type	mechanical seal	sealless	sealless
Material (wetted parts)	Polypropylene, ETFE, ceramic oxide/PTFE/carbon, FKM, Hastelloy C	Polypropylene, ETFE, PTFE/carbon, Hastelloy C	Stainless steel 1.4571, ETFE, PTFE/carbon
Outer-Ø	32 mm	32 mm	28 mm
Thread on outlet	G 1 A (BSP 1" male) Hose connections DN 13 and DN 19 included with the pump.		G ¾ A (BSP ¾" male) Part numbers of hose connections see accessories page 6
Motor	Commutator motor 230 Watt, 240, 230 Volt, 50 Hz or 110 Volt, 50-60 Hz, double insulated, protection class II, splash-proof to IP 24, with overload cut-out switch, 2-speed switch, 5 m power supply cable with 2-pole plug		
Delivery rate max.	47 l/min	57 l/min	57 l/min
Delivery head max.	6,8 m	8,5 m	8,5 m
Viscosity max.	250 mPas (cP)	250 mPas (cP)	250 mPas (cP)
Temperature max.	45 °C	45 °C	80 °C
Part No. 230 Volt*/Weight			
Immersion length 500 mm	310 42 005/1,8 kg	314 42 005/2,0 kg	314 21 005/2,8 kg
Immersion length 700 mm	310 42 007/2,0 kg	314 42 007/2,2 kg	314 21 007/3,0 kg
Immersion length 1000 mm	310 42 010/2,1 kg	314 42 010/2,4 kg	314 21 010/3,2 kg
Part No. 240 Volt*/Weight			
Immersion length 500 mm	310 42 405/1,8 kg	314 42 405/2,0 kg	314 21 405/2,8 k
Immersion length 700 mm	310 42 407/2,0 kg	314 42 407/2,2 kg	314 21 407/3,0 kg
Immersion length 1000 mm	310 42 410/2,1 kg	314 42 410/2,4 kg	314 21 410/3,2 kg
Part No. 110 Volt*/Weight			
Immersion length 500 mm	310 42 205/1,8 kg	314 42 205/2,0 kg	314 21 205/2,8 kg
Immersion length 700 mm	310 42 207/2,0 kg	314 42 207/2,2 kg	314 21 207/3,0 kg
Immersion length 1000 mm	310 42 210/2,1 kg	314 42 210/2,4 kg	314 21 210/3,2 kg

*tested to German VDE and GS specifications

Performance Chart

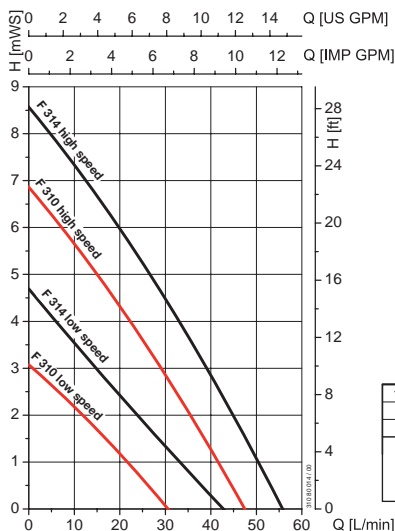

Messwerte / Values / Valeurs: ± 10%

Dimensions F 310 PP-32/25 and F 314 PP-32/25

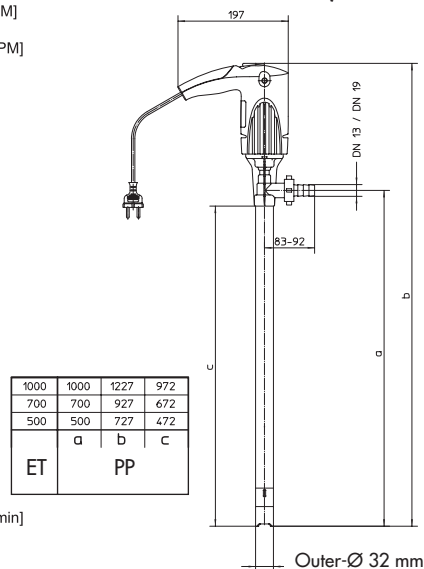

Dimensions F 314 S-28/25

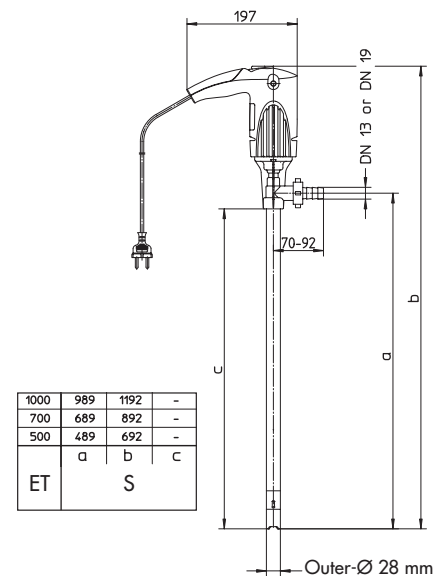

Pump Kit and Accessories



Description	Part No./Weight
FLUX Pump Kit JUNIORFLUX, consisting of	
1 JUNIORFLUX F 314 PP-25/19 230 Volt, 50 Hz, 230 Watt, IP 24, immersion length 700 mm	314 43 007/2,40 kg
1 Hose connection PP, DN 13	
1,5 m flexible PVC hose DN 13	
2 Hose clips	
1 Hand tap PP, DN 13, seal FKM	
FLUX Pump Kit JUNIORFLUX, consisting of	
1 JUNIORFLUX F 314 PP-32/25 230 Volt, 50 Hz, 230 Watt, IP 24, immersion length 1000 mm	314 43 010/2,60 kg
1 Hose connection PP, DN 19	
1,5 m flexible PVC hose DN 19	
2 Hose clips	
1 Hand tap PP, DN 19, seal FKM	
Hand tap PP with small outlet nozzle	
for filling and dispensing of neutral or corrosive liquids. Material: Polypropylene Seal: FKM	
Inlet with hose connector DN 13, outlet nozzle Ø 11 mm	001 13 034/0,11 kg
Inlet with hose connector DN 19, outlet nozzle Ø 20 mm	001 13 000/0,11 kg
Flexible PVC hose with wire-helix	
for neutral or corrosive liquids. Operating pressure: max. 2 bar Temperature: max. 60 °C	
Nominal-Ø DN 13, outer-Ø 18 mm	001 10 039/0,21 kg
Nominal-Ø DN 19, outer-Ø 27 mm	001 10 040/0,34 kg
Hose connection complete	
consisting of nut, hose connector and seal	
with nut G ¾ female for F 314 S:	
Nominal-Ø DN 13, material: stainless steel	959 04 133/0,03 kg
Nominal-Ø DN 19, material: stainless steel	959 04 147/0,03 kg

The great Range of FLUX Pumps



Yes!

I am interested in top class pump technology.
Please send the following catalogues:

- | | |
|---|--|
| <input type="checkbox"/> FLUX Barrel and Container Pumps | <input type="checkbox"/> FLUX Centrifugal Immersion Pumps |
| <input type="checkbox"/> FLUX Pump Kits | <input type="checkbox"/> FLUX Air-operated Diaphragm Pumps |
| <input type="checkbox"/> FLUX High Viscosity Liquid Pumps | <input type="checkbox"/> FLUX Mixers |
| | <input type="checkbox"/> FLUX Liquid Meters |

Name

Company

Address

Telephone

Fax

E-mail

Please mark with a cross, complete the address and then send us a fax. Fax number see on the back side!



Innovators in Flow Technology



All around the globe, FLUX is synonymous with top standards in pump technology. Whether it is barrel pumps, high viscosity liquid pumps, vertical centrifugal immersion pumps, air-operated diaphragm pumps, liquid meters, mixers or top class accessories – FLUX with its complete and comprehensive range is always the one to address to. Benefit from our competence. We look forward to hearing from you!

FLUX-GERÄTE GMBH
Talweg 12 · D-75433 Maulbronn
Tel. 070 43/101-0 · Fax 070 43/101-444
Fax International +49 70 43 / 1 01 -555
info@flux-pumpen.de · www.flux-pumpen.com



Innovators in Flow Technology



All around the globe, FLUX is synonymous with top standards in pump technology. Whether it is barrel pumps, high viscosity liquid pumps, vertical centrifugal immersion pumps, air-operated diaphragm pumps, liquid meters, mixers or top class accessories – FLUX with its complete and comprehensive range is always the one to address to. Benefit from our competence. We look forward to hearing from you!

FLUX PUMPS INTERNATIONAL (U.K.)
12 Enterprise Park, Blackmoor Road
Verwood, Dorset BH31 6YS
Tel. (01202) 823304 · Fax (01202) 813387
info@flux-pumps.co.uk · www.flux-pumps.co.uk