



Flojet LF Plus

LOW FLOW INDUSTRIAL MOTOR DRIVEN DIAPHRAGM PUMPS

The New LF Plus Motor Driven Industrial Pumps are backed by Flojet's diaphragm pump technology, a brand enjoying over 35 years of operational excellence.

Flojet's new LF Series compact pumps offer up to a 1.0 GPM (3.8 LPM) flow rate and optional industry leading switch technology, proven with over 1 million cycles. The 360° quick connect swivel ports allow for complete freedom of port orientation, a cost effective solution, minimizing the need for additional components. These pumps are the ideal solution for many applications including spraying, fluid transfer, filtration, cooling, dispensing and pressure boosting.

The Flojet LF Plus pumps are made from Geolast® or Santoprene® diaphragm and EPDM or Viton® check valves, resulting in true compatibility with most harsh and abrasive chemicals.

Features and Benefits:

- Flow rates up to 1.0 GPM (3.8 LPM.) and operating pressures up to 40 PSI (2.75 bar)
- Demand (pressure switch shut-off) or non-switch models available
- Bypass option reduces cycling, offering ideal pressures of 0.2 to 0.3 GPM for backpack spraying
- Robust material selection, suitable for handling a broad range of chemicals
- Sealed motor and pressure switch, providing years of dependable reliability
- Flojet Diaphragm pumps provide dependable run dry capabilities, extending the life of the pump
- Self priming, accommodating up to 6ft. (1.8m)
- Built in thermal protector, prevents overheating to protect the pump from damage
- Quick Disconnect Ports allow for quick cleaning and easy hose replacement in seconds
- Low amp draw, ideal for battery powered applications



FLOJET
a xylem brand

LF PLUS LOW FLOW INDUSTRIAL MOTOR DRIVEN DIAPHRAGM PUMP

Applications



General Industrial

- Chemical Washdown
- Evaporative Cooling Systems
- Fluid Transfer
- RO Filtration
- Food Processing
- Water Dispense



Agricultural

- Fogging / Misting
- ATV & Backpack Sprayers



Automotive

- Fluid Exchange



Head-Flow Chart

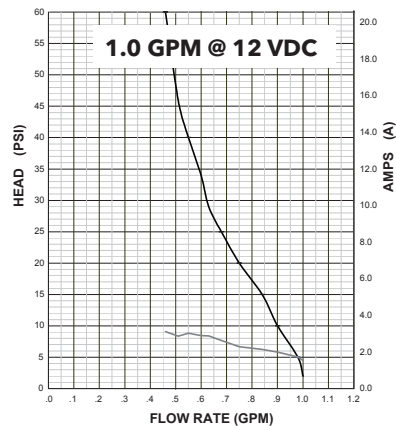
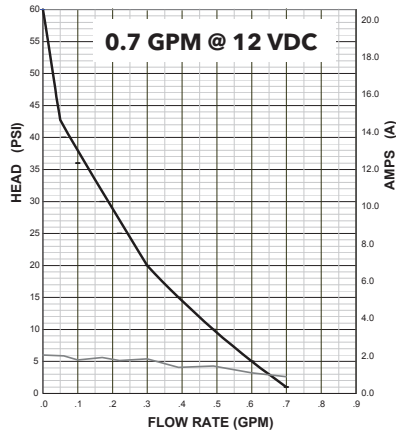

Specifications

Pump Design	Reciprocating Diaphragm
Maximum Flow Rate	1.0 GPM (3.78 LPM) @ open flow
Duty Cycle	Intermittent
Housing Material	Polypropylene
Diaphragm Elastomers	Santoprene®, Geolast®
Check Valve Materials	EPDM, Viton®
Check Valve Spring	316 Stainless Steel
Port Type	Quick Disconnect - 3/8 HB Straight, Celcon**
Operating Pressure	40 PSI (2.75 Bar) Max. (no pressure switch version)
Pressure Switch Setting	40 PSI (2.75 Bar) Off / 25 PSI (1.7 Bar) On
Self Priming	Up to 6ft. (1.8m)
Liquid Temperature	110° F (43° C) Maximum
Motor Type	Permanent Magnet Motor
Motor Voltage	12 VDC, 24 VDC, 115 VAC
Current for 12 VDC	2.5 Amps @ 25 PSI (1.7 Bar)
Certifications	CSA, CE*, NSF*, UL*
Weight	1.25 lbs. (0.5 Kg)

*Available on certain models

**Reference datasheet PN#81000-230 for additional fittings

Dimensional Drawing

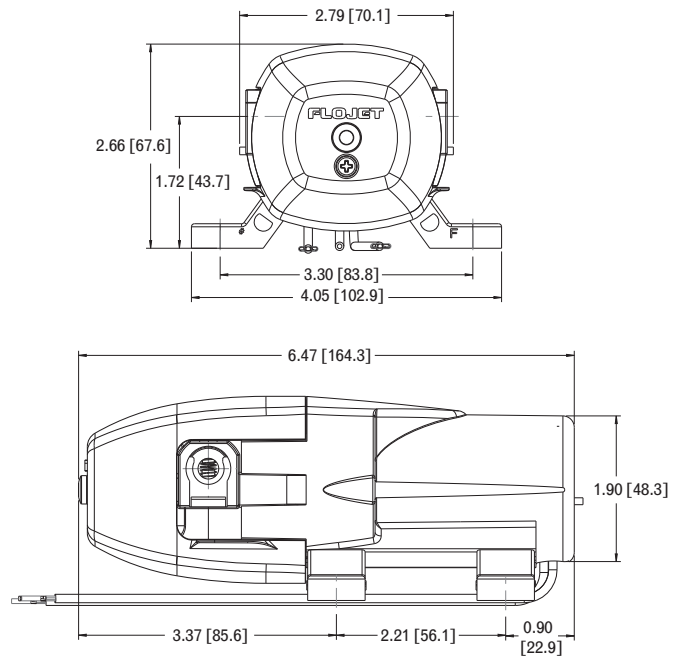

Dimensions in inches [mm]

Part No.	Volts	GPM (LPM)	Pressure Switch	Switch PSI (Bar)	Diaphragm	Check Valve	Port Fitting	Certifications
LFP122005	12	1.0 (3.78)	NO	40 (2.75)	Geolast	Viton	3/8 HB Straight, Celcon	CSA,
LFP121421	12	0.7 (2.70)	YES	40 (2.75)	Santoprene	Viton	3/8 HB Straight, Celcon	CSA,
RLFP222201	24	1.0 (3.78)	YES	40 (2.75)	Santoprene	Viton	3/8 HB Straight, Celcon	CSA, CE
LFP122201 (Available March 2012)	12	1.0 (3.78)	YES	40 (2.75)	Santoprene	Viton	3/8 HB Straight, Celcon	CSA,
LFP122202 (Available March 2012)	12	1.0 (3.78)	YES	40 (2.75)	Santoprene	EPDM	3/8 HB Straight, Celcon	CSA, NSF
LFP521002 (Available March 2012)	115	0.7 (2.70)	NO	40 (2.75)	Santoprene	EPDM	3/8 HB Straight, Celcon	CSA, NSF, UL

Geolast® & Santoprene® is a registered trademark of Monsanto.
Viton® is registered trademark of DuPont Performance Elastomers.

xylem
Let's Solve Water

Xylem, Inc.
USA
17942 Cowan
Irvine, CA 92614
Tel +1.714.557.4700
Fax +1.714.628.7890

Xylem, Inc.
ENGLAND
Bingley Road, Hoddesdon
Hertfordshire EN11 OBU
Tel: +44 (0) 1992 450145
Fax: +44 (0) 1992 467132

Xylem, Inc.
CHINA
30/F Tower A
100 Zunyi Road
Shanghai, China 200051
Tel: +86-21-2208-2888
Fax: +86-21-2208-2999

Xylem, Inc.
GERMANY
Oststrasse 28
22844 Norderstedt
Tel: +49-40-53 53 73-0
Fax: +49-40-53 53 73-11

Xylem, Inc.
ITALY
Via Tommaseo, 6
20059 Vimercate, Milano
Tel: +39 039 685 2323
Fax: +39 039 666 307