

## 2500 SERIES PUMPS

**Edson's 2500 Series Pumps are outstanding, electric powered, double diaphragm, plastic, transfer pumps.**

The Edson 2500 series pumps combine pumping features that include **dry start suction lift**, the ability to **pump liquids with suspended solids**, a **low emulsion pumping action** and the ability to **run dry indefinitely** with the **chemical resistsants** of polypropylene.

The 2500 series pumps are available as:

**The Model 2500** - a variable speed, inverter controlled version that includes a VFD mounted to a 3/4 hp integral gear motor.

**The Models 25060, 25050, 25040, 25030 & 25020** - fixed speed versions each of which are built with 1 of 5 different ratio gear reducers and to which you can mount any 3/4 Hp (.55kw), 56C frame motor to create a pump that meets the performance and electrical specifications needed for your application. **The motor for a 25060 thru 25020 is ordered separately. (On page 4 is a partial list of motors available from Edson for these fixed speed pumps.)**

Flexibility in a simple to understand and maintain package, the 2500s can do just about any pumping task you need done at suction lifts up to 25 ft, discharge heads up to 25 ft and volumes up to 25 gpm.



**Model 2500**  
Variable Speed Version  
Shown With Optional Wheels and Handle



**Model 25060**  
Fixed Speed Version  
Shown With A 110/230V Single Phase TEFC Motor and Optional Wheels and Handle

### SPECIFICATIONS

#### Pump Drive:

##### Model 2500

- Variable Speed Programmable Drive Includes:  
.75 hp / .55 kw; 60/50 hz; TEFC Gear Motor  
Lenze VFD Wired for 110V Input.  
*Optional VFDs are available to match any voltage and frequency.*

##### Models 25060, 25050, 25040, 25030, 25020

- One of 5 Different Ratio Gear Reducers:  
Model 25060 is built with a 30 to 1 gear reducer.  
Model 25050 is built with a 34 to 1 gear reducer.  
Model 25040 is built with a 43 to 1 gear reducer.  
Model 25030 is built with a 60 to 1 gear reducer.  
Model 25020 is built with a 83 to 1 gear reducer.
- Optional .75 hp / .55 kw; 60/50 hz Motor  
*Motors for the Models 25060, 25050, 25040, 25030 and 25020 are ordered separately. Edson offers a wide range of motors to meet any conditions. See page 4 for a partial list.*

#### Pump Construction All Models:

- 2 Polypropylene Pump Bodies.
- Inlet & Discharge Ports - 1.5+MNPT Polypropylene
- Diaphragm - Viton
- Valve Assembly - Viton, Flapper Type
- Optional Stainless Handle and 8+Wheels  
*Handle and Wheels are optional for portable applications.*

#### Pump Performance All Models:

- Max Volume:  
**Model 2500** - 25 gpm / 94.6 lpm / 5.68 m<sup>3</sup>hr.  
**Models 25060, 25050, 25040, 25030, 25020** -  
Varies based on model and motor combination.  
*See page 3 for details.*
- Suction Lift to 25 ft / 7.62 meters
- Dry Prime Suction Lift to 12 ft / 3.657 meters
- Discharge Head to 25 ft / 7.62 meters

## DIMENSIONS

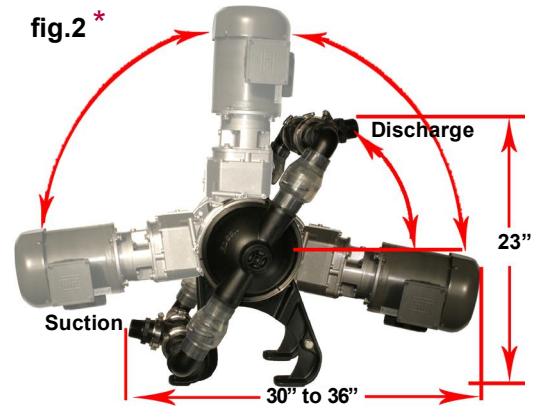
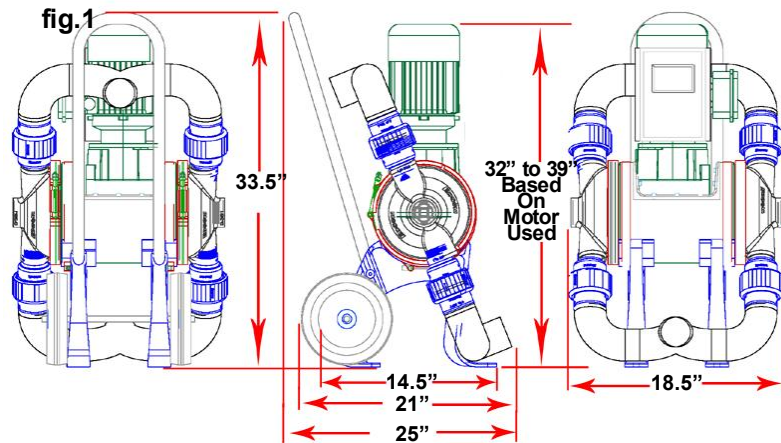

**\* As shown in fig.2 the dimensions can change because the pump drive and mounting assembly can be rotated forward or backwards on the support legs and because the pump chambers which includes the suction and discharge plumbing can also be rotated on the pump frame.**

## APPLICATIONS & CONFIGURATIONS

**What Can You Do With A 2500?** Clean out a process tank? Test and pump remediation site wells? Transfer liquid? Pump liquids with suspended solids? Suck out a sump? Transfer waste water from wash down stations? Transfer contaminated liquids with very low emulsive pumping action? Sewage transfer or collection? Transfer or collect all types of liquids?

**Need Versatility?** The 2500 version with itsqVFD lets you match the pump performance to the application at hand. See the Performance Charts on page 3. You can get the pump performance you need with just the push of a button. The Variable Frequency Drive also allows for remote start-stop stations, float switch control, setting run times and a variety of other capabilities.

**Want To Just Keep It Simple?** The 25060, 25050, 25040, 25030, 25020 versions are built to run at a fixed speed determined by the model and the motor combination. If your application calls for the pump to perform at just one cycle rate, we can supply the pump with the gear reducer and motor combination to meet just that performance rate. See Pump Cycles Per Minute Chart on page 3.

**Need 1 Pump To Do 2 Jobs?** The inlet and discharge of a 2500 Series pump can be reconfigured so each of the 2 pump bodies has individual suction and/or discharge lines. One 2500 can be used as two pumps with a common drive.

**Need High Suction Lift For A Dry Hose Start?** Add the optional high suction lift plumbing. Prime the pump and keep it primed even when the suction line runs dry. In factory tests, the vacuum gauge recorded 25-hg when this optional plumbing was used on the inlet of the pump.

**Pump Dimensions Not Right?** Consider rotating the drive modular from vertical to horizontal.



## 2500 SERIES PUMP PERFORMANCE CHARTS

The following charts are a guide in determining which version of the 2500 is best for a specific application. Each of the charts show the gallons per minute (**gpm**) performance of a 2500 pump operating at a different speeds (**Cycle/ Minute**) under 25 different combinations of suction pressure in inches of mercury (**hg**) and discharge pressure in pounds per square inch (**psi**). These suction and discharge pressures are also displayed as suction and discharge head in both feet and meters. **The cycle rate** of the pump and the suction and discharge pressures created by a specific application will determine the actual volume performance of the pump being used.

Results In Gallon Per Minute  
1 Gallon Per Min. = 3.785 Liters Per Min. = .2271 Cubic Meters Per Hour

		Discharge Head				
		5 ft / 1.52 m	10 ft / 3.04 m	20 ft / 6.09 m	25 ft / 7.62 m	
60 Cycles / Min.		0	2.2 psi	4.4 psi	8.7 psi	10.8 psi
Suction Head	0	25.0 gpm	21.4 gpm	20.0 gpm	16.7 gpm	12.5 gpm
5 ft / 1.52 m	4.5 hg	25.0 gpm	21.4 gpm	20.0 gpm	16.7 gpm	12.5 gpm
10 ft / 3.04 m	9.1 hg	21.4 gpm	16.7 gpm	14.3 gpm	11.5 gpm	11.1 gpm
20 ft / 6.09 m	18.2 hg	18.8 gpm	16.7 gpm	12.5 gpm	10.7 gpm	10.3 gpm
25 ft / 7.62 m	22.7 hg	15.0 gpm	14.3 gpm	11.5 gpm	10.7 gpm	10.0 gpm

		Discharge Head				
		5 ft / 1.52 m	10 ft / 3.04 m	20 ft / 6.09 m	25 ft / 7.62 m	
40 Cycles / Min.		0	2.2 psi	4.4 psi	8.7 psi	10.8 psi
Suction Head	0	15.8 gpm	12.5 gpm	11.5 gpm	10.0 gpm	9.4 gpm
5 ft / 1.52 m	4.5 hg	15.0 gpm	12.5 gpm	11.5 gpm	10.0 gpm	9.4 gpm
10 ft / 3.04 m	9.1 hg	13.6 gpm	11.5 gpm	10.3 gpm	8.8 gpm	8.8 gpm
20 ft / 6.09 m	18.2 hg	12.5 gpm	11.1 gpm	9.4 gpm	6.3 gpm	5.0 gpm
25 ft / 7.62 m	22.7 hg	10.0 gpm	9.4 gpm	6.0 gpm	5.0 gpm	4.4 gpm

		Discharge Head				
		5 ft / 1.52 m	10 ft / 3.04 m	20 ft / 6.09 m	25 ft / 7.62 m	
30 Cycles / Min.		0	2.2 psi	4.4 psi	8.7 psi	10.8 psi
Suction Head	0	12.0 gpm	10.7 gpm	10.0 gpm	8.3 gpm	7.9 gpm
5 ft / 1.52 m	4.5 hg	10.7 gpm	10.7 gpm	7.5 gpm	5.6 gpm	5.0 gpm
10 ft / 3.04 m	9.1 hg	10.0 gpm	8.8 gpm	6.7 gpm	5.0 gpm	4.5 gpm
20 ft / 6.09 m	18.2 hg	8.3 gpm	7.1 gpm	5.0 gpm	4.2 gpm	3.8 gpm
25 ft / 7.62 m	22.7 hg	7.1 gpm	6.0 gpm	4.3 gpm	3.8 gpm	3.5 gpm

		Discharge Head				
		5 ft / 1.52 m	10 ft / 3.04 m	20 ft / 6.09 m	25 ft / 7.62 m	
20 Cycles / Min.		0	2.2 psi	4.4 psi	8.7 psi	10.8 psi
Suction Head	0	6.3 gpm	6.0 gpm	4.7 gpm	4.3 gpm	4.1 gpm
5 ft / 1.52 m	4.5 hg	6.0 gpm	4.7 gpm	4.1 gpm	3.3 gpm	3.0 gpm
10 ft / 3.04 m	9.1 hg	6.0 gpm	4.1 gpm	3.5 gpm	3.0 gpm	2.9 gpm
20 ft / 6.09 m	18.2 hg	5.0 gpm	3.3 gpm	3.0 gpm	2.6 gpm	2.4 gpm
25 ft / 7.62 m	22.7 hg	4.4 gpm	3.0 gpm	2.3 gpm	2.1 gpm	1.9 gpm

### CYCLE RATES

The **Model 2500** is built with a variable speed, programable control (VFD-Variable Frequency Drive) wired to a 60 rpm gear motor that allows the operator to just dial in the cycle rate of the pump to meet the performance requirements of the application. Cycle rates from 0 to 60 at the push of a button.

The **Models 25060 25050 25040 25030 and 25020** are built with specific ratio gear reducers. Since each can be ordered with a variety of motors, the actual cycle per minute rate of the pump will be determined by the combination of the pump and the rpm of the motor ordered. Use the following chart to determine the best combination for your application.

#### Example:

The Model 25060 pump is built with a 30 to 1 ratio gear reducer.

The Motor 161-A-1432 is 12 volt, dc motor with a speed of 1800 rpm.

The cycle rate of the pump with this combination will be 60 cycles/min.  
1800 divided by 30

$$\frac{\text{Motor RPM}}{\text{Gear Reducer Ratio}} = \text{Pump Cycle Rate}$$

		Pump Model No. and Gear Reducer Ratio				
		25060	25050	25040	25030	25020
		30 to 1	34 to 1	43 to 1	60 to 1	83 to 1
Typical Motor RPMs	1150	38.3	33.8	26.7	19.2	13.9
	1425	47.5	41.9	33.1	23.8	17.2
	1725	57.5	50.7	40.1	28.7	20.8
	1745	58	51.3	40.6	29.1	21
	1800	60	52.9	41.8	30	21.7
	2850			66.2	47.5	34.3
	3450				57.5	41.5

**Pump Cycle Rates Per Minute**



***PARTIAL LIST OF MOTORS  
AVAILABLE FOR THE 25060 25050 25040 25030 & 25020 PUMPS  
(Motors are ordered separately with these pumps.)***



**60 Hertz Totally Enclosed Fan Cooled Motors**

Order No.	Description
161-A-161	3/4Hp 115/208-230V 60Hz 1745Rpm 1Ph TEFC Motor
161-A-1429	3/4Hp 208-230/460V 60Hz 1745Rpm 3Ph TEFC Motor



**12 Volt Totally Enclosed Fan Cooled Motors**

Order No.	Description
161-A-1432	3/4Hp 12 Volt DC 1800Rpm TEFC Motor
161-A-1433	3/4Hp 24 Volt DC 1800Rpm TEFC Motor



**Explosion Proof Motors**

Order No.	Description
161-A-1430	3/4Hp 115/208-230V 60Hz 1725Rpm 1Ph Explosion Proof Mtr
161-A-1431	3/4Hp 208-230/460V 60Hz 1725Rpm 3Ph Explosion Proof Mtr
161-A-1500	3/4Hp 115/208-230V 50Hz 2850Rpm 1Ph Explosion Proof Mtr
161-A-1557	3/4Hp 208-230/460V 50Hz 1425Rpm 3Ph Explosion Proof Mtr



**50 Hertz Totally Enclosed Fan Cooled Motors**

Order No.	Description
161-A-1501	3/4Hp 115/208-230V 50Hz 2850Rpm 1Ph TEFC Motor
161-A-1558	3/4Hp 115/208-230V 50Hz 1425Rpm 1Ph TEFC Motor
161-A-1559	3/4Hp 208-230/460V 50Hz 2850Rpm 3Ph TEFC Motor
161-A-1560	3/4Hp 208-230/460V 50hz 1425Rpm 3Ph TEFC Motor