

Demersible Chopper Pumps

#5 Frame Driver

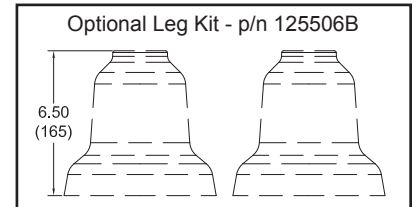
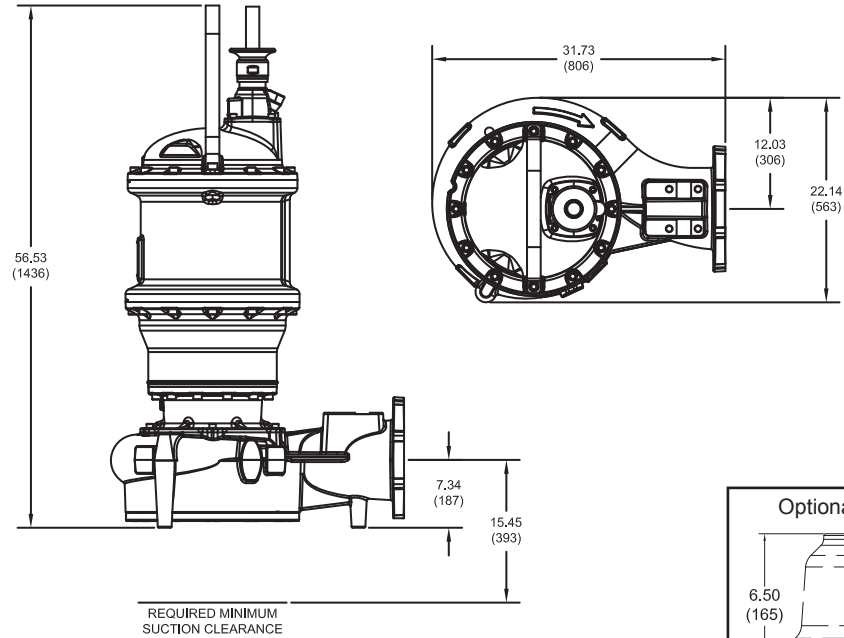

| Model No. | Imp. Dia. inches (mm) | HP | Volt | PH | Hz | RPM | NEMA Start Code | Full Load Amps | S.F. | S.F. Amps | Locked Rotor Amps | Cord P/N ▲ | Cord Size |
|------------------|-----------------------|-------|------|----|----|------|-----------------|----------------|------|-----------|-------------------|------------|--------------|
| 7366*-867-68-32N | ** | 100.0 | 460 | 3 | 60 | 1750 | E | 136.6 | 1.15 | 155.3 | 578.0 | 138319 | 2/4 - 18/4 |
| 7366*-867-83-32N | ** | 100.0 | 575 | 3 | 60 | 1750 | E | 109.2 | 1.15 | 124.2 | 462.4 | 138319 | 2/4 - 18/4 |
| 7366*-867-69-32N | 12.60 (320) | 125.0 | 460 | 3 | 60 | 1750 | F | 169.4 | 1.15 | 191.5 | 800.0 | 138320 | 1/0/4 - 18/4 |
| 7366*-867-84-32N | 12.60 (320) | 125.0 | 575 | 3 | 60 | 1750 | F | 135.6 | 1.15 | 153.2 | 640.0 | 138319 | 2/4 - 18/4 |
| 7366*-867-97-32N | 13.78 (350) | 150.0 | 460 | 3 | 60 | 1750 | D | 187.0 | 1.0 | 187.0 | 800.0 | 138320 | 1/0/4 - 18/4 |
| 7366*-867-1G-32N | 13.78 (350) | 150.0 | 575 | 3 | 60 | 1750 | D | 159.5 | 1.0 | 159.5 | 640.0 | 138320 | 1/0/4 - 18/4 |

IMPORTANT !

Moisture and Temperature sensor leads are integral to power cord.
 Pump rated for operation at ± 10% voltage at motor.
 ▲ Cord Suffix: XC - 30 Feet, XF - 50 Feet, XJ - 75 Feet, or XL - 100 Feet.
 ▲ Cord sold separately.
 ** Select impeller diameter when ordering.