

# Size 6MH (Mono Vane)

7366\*-617

# DEMING®

www.cranepumps.com

## Demersible Chopper Pumps

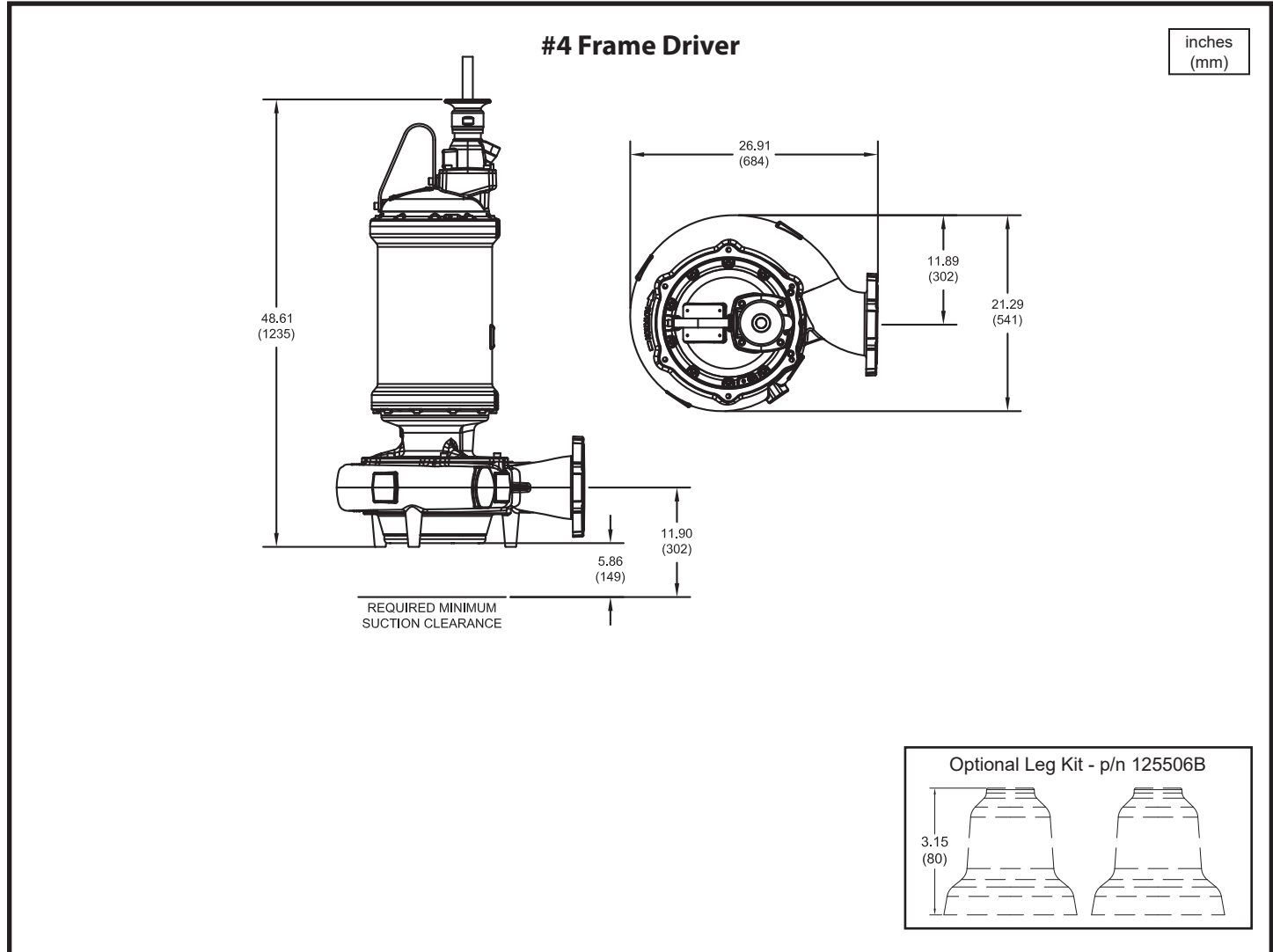

Model No.	Imp. Dia. inches (mm)	HP	Volt	PH	Hz	RPM	NEMA Start Code	Full Load Amps	S.F.	S.F. Amps	Locked Rotor Amps	Cord P/N ▲	Cord Size
7366*-617-65-32N	12.80 (325)	50	460	3	60	1750	F	67.1	1.2	79.0	339.0	138318	6/4 - 18/4
7366*-617-80-32N	12.80 (325)	50	575	3	60	1750	F	53.7	1.2	63.2	271.2	138318	6/4 - 18/4
7366*-617-66-32N	13.58 (345)	60	460	3	60	1750	E	79.0	1.2	95.5	339.0	138319	2/4 - 18/4
7366*-617-81-32N	13.58 (345)	60	575	3	60	1750	E	63.2	1.2	76.4	271.2	138318	6/4 - 18/4

\* FOR NON-EXPLOSION PROOF (STANDARD) MODELS, USE FIGURE NUMBER 7366N.

▲ CORD SOLD SEPARATELY.

**IMPORTANT !**

- 1.) MOISTURE AND TEMPERATURE SENSORS **MUST** BE CONNECTED TO VALIDATE THE CSA LISTING.
- 2.) A SPECIAL MOISTURE SENSOR RELAY IS REQUIRED IN THE CONTROL PANEL FOR PROPER OPERATION OF THE MOISTURE SENSORS. CONTACT CP&S FOR INFORMATION CONCERNING MOISTURE SENSING RELAYS FOR CUSTOMER SUPPLIED CONTROL PANELS.
- 3.) THESE PUMPS ARE CSA LISTED FOR PUMPING WATER AND WASTEWATER. **DO NOT USE TO PUMP FLAMMABLE LIQUIDS.** NOT SUITABLE FOR ENVIRONMENTS CONTAINING GASOLINE OR HEXANE.
- 4.) INSTALLATIONS SUCH AS DECORATIVE FOUNTAINS OR WATER FEATURES PROVIDED FOR VISUAL ENJOYMENT MUST BE INSTALLED IN ACCORDANCE WITH THE NATIONAL ELECTRIC CODE ANSI/NFPA 70 AND/OR THE AUTHORITY HAVING JURISDICTION. THIS PUMP IS NOT INTENDED FOR USE IN SWIMMING POOLS, RECREATIONAL WATER PARKS, OR INSTALLATIONS IN WHICH HUMAN CONTACT WITH PUMPED MEDIA IS A COMMON OCCURRENCE.
- 5.) A **NON-SPARKING** BREAKAWAY FITTING MUST BE USED TO VALIDATE THE EXPLOSION PROOF LISTING.
- 6.) WINDING RESISTANCE ± 7.5%. WINDING RESISTANCE MEASURED IN OHMS @ 25°C (BETWEEN LINES) AT MOTOR LEADS.
- 7.) PUMP RATED FOR OPERATION AT ± 10% VOLTAGE AT MOTOR.
- 8.) CORD SUFFIX: XF - 50 FEET, XJ - 75 FEET, OR XL - 100 FEET. CORD SOLD SEPARATELY.
- 9.) ALL EXPLOSION PROOF PUMPS AND MOTORS ARE CSA EXPLOSION-PROOF TO CLASS I DIVISION 1 GROUPS C&D T4 RATING

SECTION 42B  
PAGE 42  
DATE 2/19

**CRANE**®

**PUMPS & SYSTEMS**

A Crane Co. Company

USA: (937) 778-8947 • Canada: (905) 457-6223 • International: (937) 615-3598

### Demersible Chopper Pumps

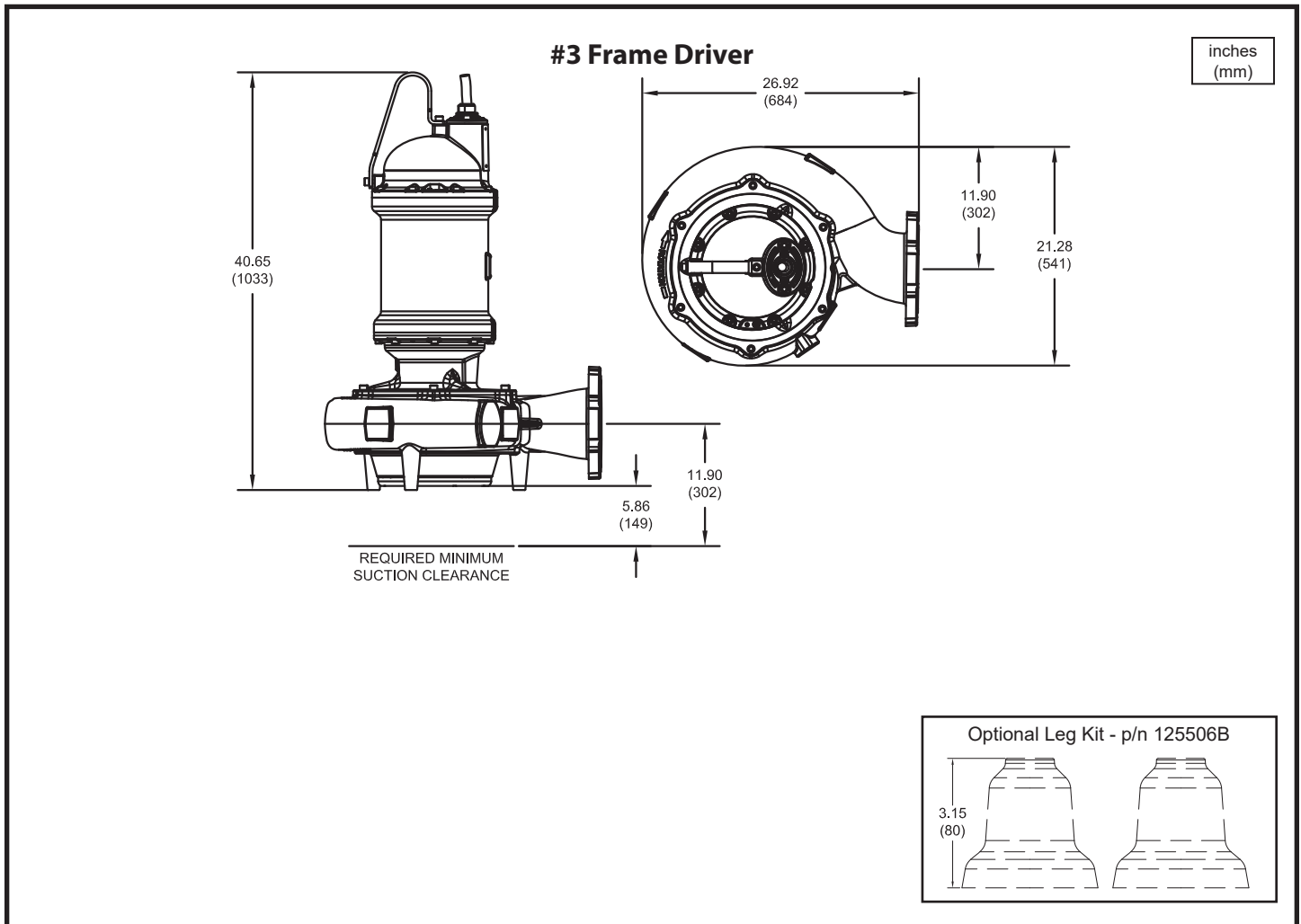

Model No.	Imp. Dia. inches (mm)	HP	Volt	PH	Hz	RPM	NEMA Start Code	Full Load Amps	S.F.	S.F. Amps	Locked Rotor Amps	Cord P/N ▲	Cord Size
7366*-621-1K-32N	12.60 (320)	15	208	3	60	1150	H	47.0	1.2	56.8	248.6	125498	8/4 - 18/4
			230					44.1		51.4		125498	8/4 - 18/4
			460					22.0		25.7		125497	12/4 - 18/4
7366*-621-75-32N	12.60 (320)	15	575	3	60	1150	H	17.6	1.2	20.6	99.4	125497	12/4 - 18/4
7366*-621-61-32N	13.58 (345)	20	460	3	60	1150	E	28.6	1.2	34.9	124.3	125499	8/4 - 18/4
7366*-621-76-32N	13.58 (345)	20	575	3	60	1150	E	22.9	1.2	27.9	99.4	125497	12/4 - 18/4

\* FOR NON-EXPLOSION PROOF (STANDARD) MODELS, USE FIGURE NUMBER 7366N.  
▲ CORD SOLD SEPARATELY.

**IMPORTANT !**

- 1.) MOISTURE AND TEMPERATURE SENSORS **MUST** BE CONNECTED TO VALIDATE THE CSA LISTING.
- 2.) A SPECIAL MOISTURE SENSOR RELAY IS REQUIRED IN THE CONTROL PANEL FOR PROPER OPERATION OF THE MOISTURE SENSORS. CONTACT CP&S FOR INFORMATION CONCERNING MOISTURE SENSING RELAYS FOR CUSTOMER SUPPLIED CONTROL PANELS.
- 3.) THESE PUMPS ARE CSA LISTED FOR PUMPING WATER AND WASTEWATER. **DO NOT USE TO PUMP FLAMMABLE LIQUIDS.** NOT SUITABLE FOR ENVIRONMENTS CONTAINING GASOLINE OR HEXANE.
- 4.) INSTALLATIONS SUCH AS DECORATIVE FOUNTAINS OR WATER FEATURES PROVIDED FOR VISUAL ENJOYMENT MUST BE INSTALLED IN ACCORDANCE WITH THE NATIONAL ELECTRIC CODE ANSI/NFPA 70 AND/OR THE AUTHORITY HAVING JURISDICTION. THIS PUMP IS NOT INTENDED FOR USE IN SWIMMING POOLS, RECREATIONAL WATER PARKS, OR INSTALLATIONS IN WHICH HUMAN CONTACT WITH PUMPED MEDIA IS A COMMON OCCURRENCE.
- 5.) A **NON-SPARKING** BREAKAWAY FITTING MUST BE USED TO VALIDATE THE EXPLOSION PROOF LISTING.
- 6.) WINDING RESISTANCE ± 7.5%. WINDING RESISTANCE MEASURED IN OHMS @ 25°C (BETWEEN LINES) AT MOTOR LEADS.
- 7.) PUMP RATED FOR OPERATION AT ± 10% VOLTAGE AT MOTOR.
- 8.) CORD SUFFIX: XF - 50 FEET, XJ - 75 FEET, OR XL - 100 FEET. CORD SOLD SEPARATELY.
- 9.) ALL EXPLOSION PROOF PUMPS AND MOTORS ARE CSA EXPLOSION-PROOF TO CLASS I DIVISION 1 GROUPS C&D T4 RATING

# Size 6MH (Mono Vane)

7366\*-621

# DEMING®

www.cranepumps.com

## Demersible Chopper Pumps

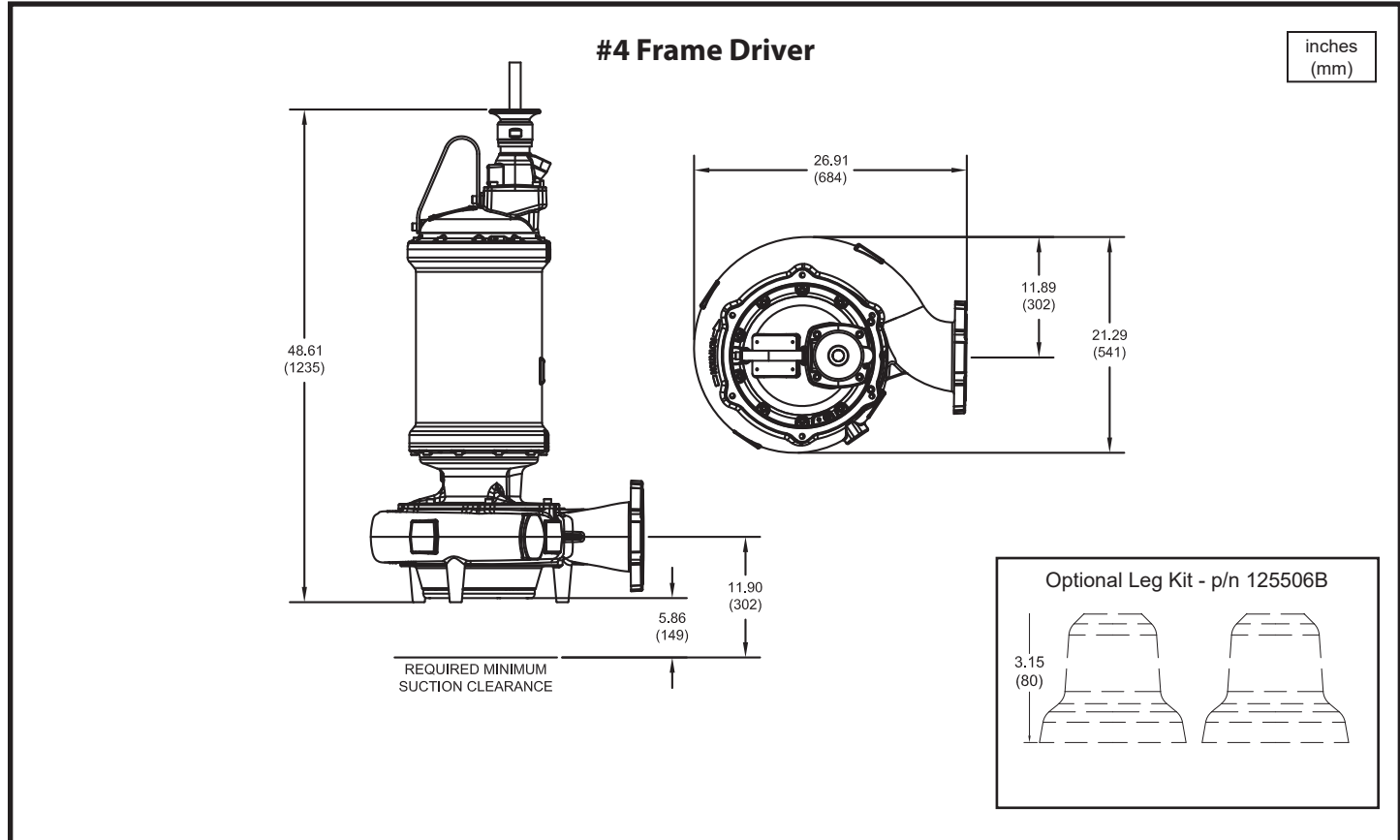

Model No.	Imp. Dia. inches (mm)	HP	Volt	PH	Hz	RPM	NEMA Start Code	Full Load Amps	S.F.	S.F. Amps	Locked Rotor Amps	Cord P/N ▲	Cord Size
7366*-621-31-32N	13.58 (345)	20	208	3	60	1150	H	60.3	1.2	71.5	354.0	138318	6/4 - 18/4
			230					57.2	1.2	69.8		138318	6/4 - 18/4
7366*-621-32-32N	13.98 (355)	25	208	3	60	1150	G	75.2	1.2	90.8	354.0	138319	2/4 - 18/4
			230					70.8	1.2	82.6			
7366*-621-92-32N	13.98 (355)	25	460	3	60	1150	G	35.4	1.2	41.3	177.0	138317	8/4 - 18/4
7366*-621-1B-32N	13.98 (355)	25	575	3	60	1150	G	28.3	1.2	33.0	141.6	138317	8/4 - 18/4
7366*-621-33-32N	14.57 (370)	30	208	3	60	1150	E	90.8	1.2	114.9	354.0	138319	2/4 - 18/4
			230					82.6	1.2	99.7		138319	2/4 - 18/4
7366*-621-93-32N	14.57 (370)	30	460	3	60	1150	E	41.3	1.2	49.9	177.0	138317	8/4 - 18/4
7366*-621-1C-32N	14.57 (370)	30	575	3	60	1150	E	33.0	1.2	39.9	141.6	138317	8/4 - 18/4

\* FOR NON-EXPLOSION PROOF (STANDARD) MODELS, USE FIGURE NUMBER 7366N.

▲ CORD SOLD SEPARATELY.

**IMPORTANT !**

- 1.) MOISTURE AND TEMPERATURE SENSORS **MUST** BE CONNECTED TO VALIDATE THE CSA LISTING.
- 2.) A SPECIAL MOISTURE SENSOR RELAY IS REQUIRED IN THE CONTROL PANEL FOR PROPER OPERATION OF THE MOISTURE SENSORS. CONTACT CP&S FOR INFORMATION CONCERNING MOISTURE SENSING RELAYS FOR CUSTOMER SUPPLIED CONTROL PANELS.
- 3.) THESE PUMPS ARE CSA LISTED FOR PUMPING WATER AND WASTEWATER. **DO NOT USE TO PUMP FLAMMABLE LIQUIDS.** NOT SUITABLE FOR ENVIRONMENTS CONTAINING GASOLINE OR HEXANE.
- 4.) INSTALLATIONS SUCH AS DECORATIVE FOUNTAINS OR WATER FEATURES PROVIDED FOR VISUAL ENJOYMENT MUST BE INSTALLED IN ACCORDANCE WITH THE NATIONAL ELECTRIC CODE ANSI/NFPA 70 AND/OR THE AUTHORITY HAVING JURISDICTION. THIS PUMP IS NOT INTENDED FOR USE IN SWIMMING POOLS, RECREATIONAL WATER PARKS, OR INSTALLATIONS IN WHICH HUMAN CONTACT WITH PUMPED MEDIA IS A COMMON OCCURRENCE.
- 5.) A **NON-SPARKING** BREAKAWAY FITTING MUST BE USED TO VALIDATE THE EXPLOSION PROOF LISTING.
- 6.) WINDING RESISTANCE ± 7.5%. WINDING RESISTANCE MEASURED IN OHMS @ 25°C (BETWEEN LINES) AT MOTOR LEADS.
- 7.) PUMP RATED FOR OPERATION AT ± 10% VOLTAGE AT MOTOR.
- 8.) CORD SUFFIX: XF - 50 FEET, XJ - 75 FEET, OR XL - 100 FEET. CORD SOLD SEPARATELY.
- 9.) ALL EXPLOSION PROOF PUMPS AND MOTORS ARE CSA EXPLOSION-PROOF TO CLASS I DIVISION 1 GROUPS C&D T4 RATING

SECTION 42B  
PAGE 44  
DATE 4/19



PUMPS & SYSTEMS

A Crane Co. Company

USA: (937) 778-8947 • Canada: (905) 457-6223 • International: (937) 615-3598