

DEMING®

INSTALLATION and OPERATION MANUAL X-Pruf® Demersible Chopper Pump

#2 Frame

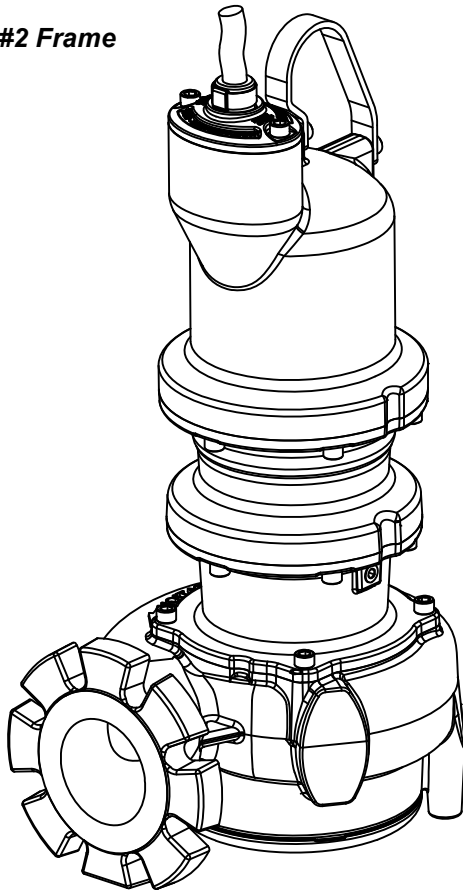

3MA
Monovane Pumps
3 - 7.5HP, 1750RPM

4M
Monovane Pumps
3 - 7.5HP, 1750RPM

4ML
Monovane Pumps
5 - 10HP, 1750RPM

4D
Dual Vane Pumps
3 - 7.5HP, 1750RPM

4DM
Dual Vane Pumps
5 - 10HP, 1750RPM

This product may be covered by one or more of the following patents and other patent(s) pending: US Patent 7,931,473, 8,128,360, NZ DSN NO. 424412, NZ DSN NO. 424413, AUS DSN NO. 201812608, AUS DSN NO. 201812609, EU Design Reg. 005293040-0001

These pumps are classified as a Class I Division 1 Groups C&D T4 Explosion-Proof by CSA to NEC and CEC specifications. Opening the motor, including maintenance of the upper mechanical seal, must be performed by CP&S to maintain the certification. Internal maintenance performed by non-certified personnel will void the explosion-proof rating

IMPORTANT!

*Read all instructions in this manual before operating pump.
As a result of Crane Pumps & Systems, Inc., constant product improvement program,
product changes may occur. As such Crane Pumps & Systems reserves the right to
change product without prior written notification.*

CRANE[®]

A Crane Co. Company

PUMPS & SYSTEMS

420 Third Street
Piqua, Ohio 45356
Phone: (937) 778-8947
Fax: (937) 773-7157
www.cranepumps.com

83 West Drive, Brampton
Ontario, Canada L6T 2J6
Phone: (905) 457-6223
Fax: (905) 457-2650



TABLE OF CONTENTS

SAFETY FIRST	3
A. GENERAL INFORMATION.....	4
B. INSTALLATION.....	4 - 12
ELECTRICAL DATA.....	6 - 12
C. START-UP OPERATION	12 - 13
D. PREVENTATIVE MAINTENANCE.....	13
E. SERVICE and REPAIR.....	13 - 14
F. REPLACEMENT PARTS	15
TROUBLE SHOOTING.....	16
XSC - CROSS-SECTION, (Fig. 9) & EXPLODED VIEW, (Fig. 10)	17 - 18
PARTS LISTS AND KITS	19 - 28
WARRANTY	31
RETURNED GOODS POLICY	32
WARRANTY REGISTRATION.....	32
START-UP REPORT	33 - 34

Other brand and product names are trademarks or registered trademarks of their respective holders.

© Deming is a registered trademark of Crane Pumps & Systems, Inc
2018

Alteration Rights Reserved

SAFETY FIRST!

Please Read This Before Installing Or Operating Pump.
This information is provided for **SAFETY and to PREVENT EQUIPMENT PROBLEMS**. To help recognize this information, observe the following symbols:



IMPORTANT! Warns about hazards that can result in personal injury or Indicates factors concerned with assembly, installation, operation, or maintenance which could result in damage to the machine or equipment if ignored.

CAUTION ! Warns about hazards that can or will cause minor personal injury or property damage if ignored. Used with symbols below.

WARNING ! Warns about hazards that can or will cause serious personal injury, death, or major property damage if ignored. Used with symbols below.



Hazardous fluids can cause fire or explosions, burns or death could result.



Extremely hot - Severe burns can occur on contact.



Biohazard can cause serious personal injury.



Hazardous fluids can Hazardous pressure, eruptions or explosions could cause personal injury or property damage.



Rotating machinery Amputation or severe laceration can result.



Hazardous voltage can shock, burn or cause death.

Only qualified personnel should install, operate and repair pump. Any wiring of pumps should be performed by a qualified electrician.



WARNING ! - To reduce risk of electrical shock, pumps and control panels must be properly grounded in accordance with the National Electric Code (NEC) or the Canadian Electrical Code (CEC) and all applicable state, province, local codes and ordinances.

WARNING! - To reduce risk of electrical shock, always disconnect the pump from the power source before handling or servicing. Lock out power and tag.



WARNING! Operation against a closed discharge valve will cause premature bearing and seal failure on any pump, and on end suction and

self priming pump the heat build may cause the generation of steam with resulting dangerous pressures. It is recommended that a high case temperature switch or pressure relief valve be installed on the pump body.



CAUTION ! Never operate a pump with a plug-in type power cord without a ground fault circuit interrupter.



CAUTION! Pumps build up heat and pressure during operation-allow time for pumps to cool before handling or servicing.



WARNING! - **DO NOT** pump hazardous materials (flammable, caustic, etc.) unless the pump is specifically designed and designated to handle them.



Do not block or restrict discharge hose, as discharge hose may whip under pressure.



WARNING! - **DO NOT** wear loose clothing that may become entangled in the impeller or other moving parts.



WARNING! - Keep clear of suction and discharge openings. **DO NOT** insert fingers in pump with power connected.



Always wear eye protection when working on pumps.



Make sure lifting handles are securely fastened each time before lifting. **DO NOT** operate pump without safety devices in place. Always replace safety devices that have been removed during service or repair. Secure the pump in its operating position so it can not tip over, fall or slide.



DO NOT exceed manufacturers recommendation for maximum performance, as this could cause the motor to overheat.

DO NOT remove cord and strain relief. Do not connect conduit to pump.



WARNING! Cable should be protected at all times to avoid punctures, cut, bruises and abrasions - inspect frequently. Never handle connected power cords with wet hands.



WARNING! To reduce risk of electrical shock, all wiring and junction connections should be made per the NEC or CEC and applicable state or province and local codes. Requirements may vary depending on usage and location.

WARNING! Submersible Pumps are not approved for use in swimming pools, recreational water installations, decorative fountains or any installation where human contact with the pumped fluid is common.



WARNING! Products Returned Must Be Cleaned, Sanitized, Or Decontaminated As Necessary Prior To Shipment, To Insure That Employees Will Not Be Exposed To Health Hazards In Handling Said Material. All Applicable Laws And Regulations Shall Apply.



Bronze/brass and bronze/brass fitted pumps may contain lead levels higher than considered safe for potable water systems. Lead is known to cause cancer and birth defects or other reproductive harm. Various government agencies have determined that leaded copper alloys should not be used in potable water applications. For non-leaded copper alloy materials of construction, please contact factory.



IMPORTANT! - Crane Pumps & Systems, Inc. is not responsible for losses, injury, or death resulting from a failure to observe these safety precautions, misuse or abuse of pumps or equipment.

SECTION A: GENERAL INFORMATION

A-1) To the Purchaser:

Congratulations! You are the owner of one of the finest pumps on the market today. CP&S pumps are products engineered and manufactured of high quality components. Over one hundred years of pump building experience along with a continuing quality assurance program combine to produce a pump which will stand up to the toughest applications. This manual will provide helpful information concerning installation, maintenance, and proper service guidelines.

A-2) Receiving:

Upon receiving the pump, it should be inspected for damage or shortages. If damage has occurred, file a claim immediately with the company that delivered the pump. **MAKE CERTAIN TO RETAIN THIS MANUAL!**

A-3) Storage:

Short Term- CP&S Pumps are manufactured for efficient performance following short inoperative periods in storage. For best results, pumps can be retained in storage, as factory assembled, in a dry atmosphere with constant temperatures for up to six (6) months.

Long Term - Any length of time exceeding six (6) months, but not more than twenty-four (24) months. The unit should be stored in a temperature controlled area, a roofed over walled enclosure that provides protection from the elements (rain, snow, wind-blown dust, etc.), and whose temperature can be maintained between +40 deg. F and +120 deg. F. (4.4 - 49°C). Pump should be stored in its original shipping container. On initial start up, rotate impeller by hand to assure seal and impeller rotate freely. If it is required that the pump be installed and tested before the long term storage begins, such installation will be allowed provided:

- 1.) The pump is not installed under water for more than one (1) month.
- 2.) Immediately upon satisfactory completion of the test, the pump is removed, thoroughly dried, repacked in the original shipping container, and placed in a temperature controlled storage area.

A-4) Service Centers:

For the location of the nearest Deming Service Center, contact Crane Pumps & Systems, Inc., Service Department in Piqua, Ohio, telephone (937) 778-8947 or Crane Pumps & Systems Canada, in Brampton, Ontario, (905) 457-6223.

SECTION B: INSTALLATION

B-1) Location:

These self-contained pumping units are recommended for use in a sump, lift station or basin. This pump is designed for submerged continuous duty (15 minutes duty in air at nameplate horsepower), pumping sewage, effluent, wastewater or other nonexplosive or noncorrosive liquids not above 104°F (40°C). Never install the pump in a trench, ditch or hole with a dirt bottom; the legs will sink into the dirt and the suction will become plugged.

B-1.1) Submergence:

It is recommended that the pump be operated in the Continuous Duty Submergence condition and the sump liquid level should never be less than the Minimum Submergence Level (See Fig. 1). The time required to draw the well down from top of motor to the minimum submergence level should not be greater than 15 minutes.

NOTE: Outer shaft seal must be in liquid when motor is operated, whether motor is submerged or in air.

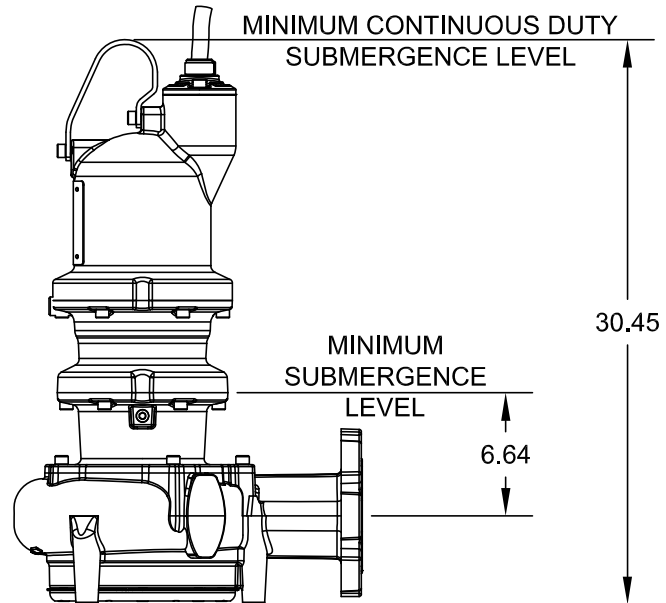

FIGURE 1

B-2) Discharge:

Discharge piping should be as short as possible. Both a check valve and a shut-off valve are recommended for each pump being used. The check valve is used to prevent backflow into the sump. Excessive backflow can cause flooding and/or damage to the pump. The shut-off valve is used to stop system flow during pump or check valve servicing.

Crane Pumps & Systems manufactures a break away fitting discharge system designed to allow the submersible wastewater pump to be installed or removed without requiring personnel to enter the wet well. Place the Break Away Fitting (BAF) in position. Temporarily secure the guide rails in the upper mounting brackets and locate the base elbow on the bottom of the wet well. Level the base elbow with grout and/or shims. Install the intermediate support brackets, if required. Make sure the rails are in a true vertical position so the pump will clear the access opening and will slide freely down the rails into place on the discharge base elbow. Once the rails are in proper alignment, bolt the base elbow into the floor of the station and connect the discharge pipe to the elbow. Connect the movable portion and other supplied fittings of the BAF onto the pump and lower into wet well. See the Break Away Fitting manual for more information.

B-3) Liquid Level Controls:

It is recommended to use a liquid level control system that allows the on and off point to be separated by at least twelve inches. An additional set point (lag point) should be incorporated with an alternator switching system for a duplex (two pump) station. A high level alarm may be required to alert maintenance personnel that there is a high water situation in the wet well should the output of the pump station drop below the inflow rate. A low level cut off may be installed to provide system shutdown if the main level control system malfunctions. The off point should be positioned so that the liquid level never drops below the minimum continuous duty point for the pump shown in figure 1.

B-4.1) Electrical Connections:

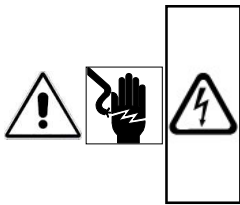

WARNING! - All model pumps and control panels must be properly grounded per the NATIONAL ELECTRIC CODE or CANADIAN ELECTRIC CODE, State, Province and local codes. Improper grounding voids warranty.

B-4) Power/Control Cord:

The power/control cord used with pump has a patented “quick disconnect” feature that allows the cord to be easily attached and disconnected at the pump. The maximum amperage rating for the cord is cast in the top of the cast stainless mounting plate. The voltage connection for the motor is determined by the cord assembly used. Low voltage cords (208 & 230 Volt) utilize a molded quick connect plug that is colored black. High voltage cords (460 & 575 Volt) utilize a molded quick connect cord that is colored orange. **It is important to verify that the cord being used is rated for the nameplate voltage and amperage rating shown on the pump nameplate. Refer to Chart on page 7.** No internal wiring adjustments are necessary for dual and tri-voltage pumps. All jumper connections to set the proper voltage are made by the cord plug itself.

A flat alignment mark is molded into the plug and mating socket on the pump. These should be used as a visual indication as to the correct orientation of the plug. Insert the plug into the pump and install the two 12 mm socket head cap screws into the clamping plate. Slowly tighten the two screws alternating back and forth until the clamping plate is drawn down flush to the top of the cord boss on the pump. The two screws should be torqued until the plate is down to a point where **metal to metal** contact is made between the stainless steel plate and pump housing. (See Fig. 2)

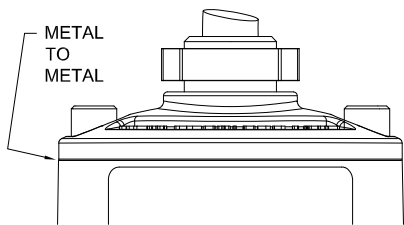

FIGURE 2a

The cord assembly mounted to the pump must not be modified in any way except for shortening to a specific application. Any splice between the pump and the control panel must be made in accordance with all applicable electric codes. It is recommended that a junction box (if used) be mounted outside the sump or be of at least Nema 6 or 6P construction with NEMA 6 or 6P watertight cord grips if located within the wet well. A water and vapor tight seal fitting **MUST** be used in conduit leaving the wet well to prevent moisture and gases from reaching the control panel. Prior to installation, the pump power cable should be inspected for nicks or damage. If damaged, the cord should be replaced before installation.

CORD CLAMPING PLATE SHOULD BE DRAWN METAL TO METAL (50 FT/LBS BOLT TORQUE). IF A GAP EXISTS CONTINUE TO TIGHTEN BOLTS. DO NOT USE ANY TYPE OF SEALANT OR GREASE ON THE CORD ENTRY.

DO NOT USE THE POWER CORD TO LIFT PUMP.

B-4.1) Electrical Connections:

When the electrical connections are made, the lead wires from the power cable should be stripped so that the ground wire is at least two inches longer than the power leads. This will ensure that if the cable is inadvertently pulled out of the connection point, the ground wire will be the last lead to break the circuit.

B-4.2) Wire Size:

If additional cable is required consult a qualified electrician for proper wire size. Voltage drop due to wire resistance between the pump and power connection point should be limited to 3% when additional cable is added.

WARRANTY NOTE:



Both the temperature sensor and moisture detection system must be connected to the motor circuitry such that the motor will be de-energized or sound alarm if excessive motor temperatures are reached and/or if water is detected in the seal chamber and/or motor chamber. Failure to have the above mentioned systems installed and operative, nullifies warranty.

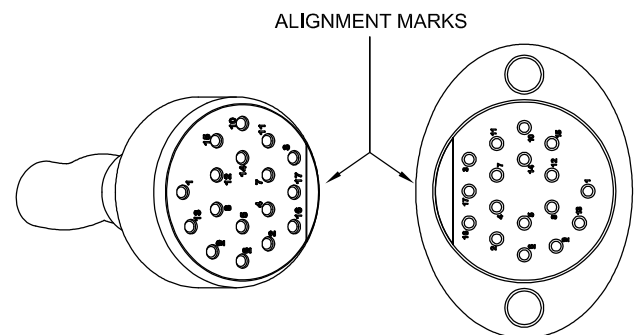

FIGURE 2b

MODEL NO	SIZE	IMP. DIA. (MM)	HP	VOLT	PH	Hz	RPM	NEMA START CODE	FULL LOAD AMPS	1-2 SERVICE FACTOR AMPS	LOCKED ROTOR AMPS	DRIVER FRAME	CORD P/N ▲	CORD SIZE	CORD O.D.	WINDING RESISTANCE
7366-335-1P-32N	3MA	6.69 (170)	3.0	208	3	60	1750	K	9.7	11.4	58.2 / 65.8	2	125496	12/4 - 18/4	.86 ± .02	1.08
				230					10.6	1.08						
				460					5.3	4.32						
7366-335-71-32N	3MA	6.69 (170)	3.0	575	3	60	1750	N	4.5	4.9	37.0	2	125497	12/4 - 18/4	.86 ± .02	4.32
				208					18.7	0.72						
				230					17.2	0.72						
7366-335-1R-32N	3MA	7.68 (195)	5.0	460	3	60	1750	J	7.5	8.6	46.2	2	125497	12/4 - 18/4	.86 ± .02	2.88
				575					6.9	4.32						
				208					28.5	0.43						
7366-335-1S-32N	3MA	8.07 (205)	7.5	230	3	60	1750	H	23.8	27.2	105.9 / 123.6	2	125496	12/4 - 18/4	.86 ± .02	0.43
				460					13.6	1.72						
				575					10.9	2.69						
7366-335-87-32N	3MA	8.07 (205)	7.5	575	3	60	1750	H	9.5	10.9	49.4	2	125497	12/4 - 18/4	.86 ± .02	2.69

▲ CORD SOLD SEPARATELY.

IMPORTANT !

- 1.) MOISTURE AND TEMPERATURE SENSORS **MUST** BE CONNECTED TO VALIDATE THE CSA LISTING.
- 2.) A SPECIAL MOISTURE SENSOR RELAY IS REQUIRED IN THE CONTROL PANEL FOR PROPER OPERATION OF THE MOISTURE SENSORS. CONTACT CP&S FOR INFORMATION CONCERNING MOISTURE SENSING RELAYS FOR CUSTOMER SUPPLIED CONTROL PANELS.
- 3.) THESE PUMPS ARE CSA LISTED FOR PUMPING WATER AND WASTEWATER. **DO NOT USE TO PUMP FLAMMABLE LIQUIDS.** NOT SUITABLE FOR ENVIRONMENTS CONTAINING GASOLINE OR HEXANE.
- 4.) INSTALLATIONS SUCH AS DECORATIVE FOUNTAINS OR WATER FEATURES PROVIDED FOR VISUAL ENJOYMENT **MUST** BE INSTALLED IN ACCORDANCE WITH THE NATIONAL ELECTRIC CODE ANSI/NFPA 70 AND/OR THE AUTHORITY HAVING JURISDICTION. THIS PUMP IS NOT INTENDED FOR USE IN SWIMMING POOLS, RECREATIONAL WATER PARKS, OR INSTALLATIONS IN WHICH HUMAN CONTACT WITH PUMPED MEDIA IS A COMMON OCCURRENCE.
- 5.) A **NON-SPARKING** BREAKAWAY FITTING **MUST** BE USED TO VALIDATE THE EXPLOSION PROOF LISTING.
- 6.) WINDING RESISTANCE ± 7.5%. WINDING RESISTANCE MEASURED IN OHMS @ 25°C (BETWEEN LINES) AT MOTOR LEADS.
- 7.) PUMP RATED FOR OPERATION AT ± 10% VOLTAGE AT MOTOR.
- 8.) CORD SUFFIX: XC - 30 FEET, XF - 50 FEET, XJ - 75 FEET, XK - 100 FEET. CORD SOLD SEPARATELY.
- 9.) ALL EXPLOSION PROOF PUMPS AND MOTORS ARE CSA EXPLOSION-PROOF TO CLASS I DIVISION 1 GROUPS C&D T4 RATING

CHART 'A'

MODEL NO	SIZE	IMP. DIA. (MM)	HP	VOLT	PH	Hz	RPM	NEMA START CODE	FULL LOAD AMPS	1.2 SERVICE FACTOR AMPS	LOCKED ROTOR AMPS	DRIVER FRAME	CORD P/N ▲	CORD SIZE	CORD O.D.	WINDING RESISTANCE
7366-424-1P-32N	4M	6.10 (155)	3.0	208	3	60	1750	K	9.7	11.4	58.2 / 65.8	2	125496	12/4 - 18/4	.86 ± .02	1.08
				230					10.6							
				460					5.3							
7366-424-71-32N	4M	6.10 (155)	3.0	575	3	60	1750	N	4.5	4.9	37.0	2	125497	12/4 - 18/4	.86 ± .02	4.32
				208					18.7							
				230					17.2							
7366-424-1R-32N	4M	7.48 (190)	5.0	460	3	60	1750	J	7.5	8.6	46.2	2	125497	12/4 - 18/4	.86 ± .02	2.88
				575					6.9							
				208					28.5							
7366-424-1S-32N	4M	7.87 (200)	7.5	230	3	60	1750	H	23.7	27.2	123.6	2	125496	12/4 - 18/4	.86 ± .02	0.43
				460					13.6							
				575					10.9							
7366-424-87-32N	4M	7.87 (200)	7.5	575	3	60	1750	H	9.5	10.9	49.4	2	125497	12/4 - 18/4	.86 ± .02	2.69
				208					18.7							
				230					17.2							
7366-410-1R-32N	4ML	7.28 (185)	5.0	460	3	60	1750	J	15.8	18.7	82.4/92.4	2	125496	12/4 - 18/4	.86 ± .02	0.72
				575					8.6							
				208					6.9							
7366-410-72-32N	4ML	7.28 (185)	5.0	575	3	60	1750	J	6.0	6.9	37.0	2	125497	12/4 - 18/4	.86 ± .02	4.32
				208					28.5							
				230					27.2							
7366-410-1S-32N	4ML	8.27 (210)	7.5	460	3	60	1750	H	11.9	13.6	61.8	2	125497	12/4 - 18/4	.86 ± .02	1.72
				575					10.9							
				208					41.4							
7366-410-87-32N	4ML	8.27 (210)	7.5	208	3	60	1750	H	23.8	28.5	105.9 / 123.6	2	125496	12/4 - 18/4	.86 ± .02	0.43
				230					27.2							
				460					13.6							
7366-410-1T-32N	4ML	8.86 (225)	10.0	575	3	60	1750	E	9.5	10.9	49.4	2	125497	12/4 - 18/4	.86 ± .02	2.69
				208					35.6							
				230					35.6							
7366-410-88-32N	4ML	8.86 (225)	10.0	460	3	60	1750	E	14.9	17.8	61.8	2	125497	12/4 - 18/4	.86 ± .02	1.72
				575					14.2							
				208					17.8							

▲ CORD SOLD SEPARATELY.

IMPORTANT !

- 1.) MOISTURE AND TEMPERATURE SENSORS **MUST** BE CONNECTED TO VALIDATE THE CSA LISTING.
- 2.) A SPECIAL MOISTURE SENSOR RELAY IS REQUIRED IN THE CONTROL PANEL FOR PROPER OPERATION OF THE MOISTURE SENSORS. CONTACT CP&S FOR INFORMATION CONCERNING MOISTURE SENSING RELAYS FOR CUSTOMER SUPPLIED CONTROL PANELS.
- 3.) THESE PUMPS ARE CSA LISTED FOR PUMPING WATER AND WASTEWATER. **DO NOT USE TO PUMP FLAMMABLE LIQUIDS.** NOT SUITABLE FOR ENVIRONMENTS CONTAINING GASOLINE OR HEXANE.
- 4.) INSTALLATIONS SUCH AS DECORATIVE FOUNTAINS OR WATER FEATURES PROVIDED FOR VISUAL ENJOYMENT MUST BE INSTALLED IN ACCORDANCE WITH THE NATIONAL ELECTRIC CODE ANS/NFPA 70 AND/OR THE AUTHORITY HAVING JURISDICTION. THIS PUMP IS NOT INTENDED FOR USE IN SWIMMING POOLS; RECREATIONAL WATER PARKS, OR INSTALLATIONS IN WHICH HUMAN CONTACT WITH PUMPED MEDIA IS A COMMON OCCURRENCE.
- 5.) A **NON-SPARKING** BREAKAWAY FITTING MUST BE USED TO VALIDATE THE EXPLOSION PROOF LISTING.
- 6.) WINDING RESISTANCE ± 7.5%. WINDING RESISTANCE MEASURED IN OHMS @ 25°C (BETWEEN LINES) AT MOTOR LEADS.
- 7.) PUMP RATED FOR OPERATION AT ± 10% VOLTAGE AT MOTOR.
- 8.) CORD SUFFIX: XC - 30 FEET, XF - 50 FEET, XJ - 75 FEET, OR XL - 100 FEET. CORD SOLD SEPARATELY.
- 9.) ALL EXPLOSION PROOF PUMPS AND MOTORS ARE CSA EXPLOSION-PROOF TO CLASS I DIVISION 1 GROUPS C&D T4 RATING

CHART 'B'

MODEL NO	SIZE	IMP. DIA. INCHES (MM)	HP	VOLT	PH	Hz	RPM	NEMA START CODE	FULL LOAD AMPS	1.2 SERVICE FACTOR AMPS	LOCKED ROTOR AMPS	DRIVER FRAME	CORD P/N ▲	CORD SIZE	CORD O.D.	WINDING RESISTANCE
7366-425-1P-32N	4D	6.30 (160)	3.0	208	3	60	1750	K	9.7	11.4	58.2 / 65.8	2	125496	12/4 - 18/4	.86 ± .02	1.08
				230					10.6							
				460					5.3							
7366-425-71-32N	4D	6.30 (160)	3.0	575	3	60	1750	N	4.5	4.9	37.0	2	125497	12/4 - 18/4	.86 ± .02	4.32
				208					18.7							
				230					17.2							
7366-425-1R-32N	4D	7.09 (180)	5.0	460	3	60	1750	J	7.5	8.6	46.2	2	125497	12/4 - 18/4	.86 ± .02	2.88
				575					6.9							
				208					28.5							
7366-425-72-32N	4D	7.09 (180)	5.0	208	3	60	1750	J	6.0	6.9	37.0	2	125497	12/4 - 18/4	.86 ± .02	4.32
				230					27.2							
				460					13.6							
7366-425-1S-32N	4D	7.48 (190)	7.5	230	3	60	1750	H	23.7	27.2	123.6	2	125496	12/4 - 18/4	.86 ± .02	0.43
				460					13.6							
				575					10.9							
7366-425-87-32N	4D	7.48 (190)	7.5	575	3	60	1750	H	9.5	10.9	49.4	2	125497	12/4 - 18/4	.86 ± .02	2.69
				208					18.7							
				230					17.2							
7366-413-1R-32N	4DM	6.50 (165)	5.0	208	3	60	1750	J	15.8	18.7	82.4 / 92.4	2	125496	12/4 - 18/4	.86 ± .02	0.72
				230					7.5							
				460					8.6							
7366-413-72-32N	4DM	6.50 (165)	5.0	575	3	60	1750	J	6.0	6.9	37.0	2	125497	12/4 - 18/4	.86 ± .02	4.32
				208					28.5							
				230					27.2							
7366-413-1S-32N	4DM	7.28 (185)	7.5	460	3	60	1750	H	23.7	27.2	123.6	2	125496	12/4 - 18/4	.86 ± .02	0.43
				575					13.6							
				208					10.9							
7366-413-87-32N	4DM	7.28 (185)	7.5	575	3	60	1750	H	9.5	10.9	49.4	2	125497	12/4 - 18/4	.86 ± .02	2.69
				208					41.4							
				230					35.6							
7366-413-1T-32N	4DM	7.08 (205)	10.0	460	3	60	1750	E	29.8	17.8	61.8	2	125497	12/4 - 18/4	.86 ± .02	1.72
				575					14.2							
				208					14.2							
7366-413-88-32N	4DM	7.08 (205)	10.0	575	3	60	1750	E	11.9	14.2	49.4	2	125497	12/4 - 18/4	.86 ± .02	2.69
				208					14.2							
				230					14.2							

▲ CORD SOLD SEPARATELY.

IMPORTANT !

- 1.) MOISTURE AND TEMPERATURE SENSORS **MUST** BE CONNECTED TO VALIDATE THE CSA LISTING.
- 2.) A SPECIAL MOISTURE SENSOR RELAY IS REQUIRED IN THE CONTROL PANEL FOR PROPER OPERATION OF THE MOISTURE SENSORS. CONTACT CP&S FOR INFORMATION CONCERNING MOISTURE SENSING RELAYS FOR CUSTOMER SUPPLIED CONTROL PANELS.
- 3.) THESE PUMPS ARE CSA LISTED FOR PUMPING WATER AND WASTEWATER. **DO NOT USE TO PUMP FLAMMABLE LIQUIDS.** NOT SUITABLE FOR ENVIRONMENTS CONTAINING GASOLINE OR HEXANE.
- 4.) INSTALLATIONS SUCH AS DECORATIVE FOUNTAINS OR WATER FEATURES PROVIDED FOR VISUAL ENJOYMENT MUST BE INSTALLED IN ACCORDANCE WITH THE NATIONAL ELECTRIC CODE ANS/NFPA 70 AND/OR THE AUTHORITY HAVING JURISDICTION. THIS PUMP IS NOT INTENDED FOR USE IN SWIMMING POOLS; RECREATIONAL WATER PARKS, OR INSTALLATIONS IN WHICH HUMAN CONTACT WITH PUMPED MEDIA IS A COMMON OCCURRENCE.
- 5.) A **NON-SPARKING** BREAKAWAY FITTING MUST BE USED TO VALIDATE THE EXPLOSION PROOF LISTING.
- 6.) WINDING RESISTANCE ± 7.5%. WINDING RESISTANCE MEASURED IN OHMS @ 25°C (BETWEEN LINES) AT MOTOR LEADS.
- 7.) PUMP RATED FOR OPERATION AT ± 10% VOLTAGE AT MOTOR.
- 8.) CORD SUFFIX: XC - 30 FEET, XF - 50 FEET, XJ - 75 FEET, OR XL - 100 FEET. CORD SOLD SEPARATELY.
- 9.) ALL EXPLOSION PROOF PUMPS AND MOTORS ARE CSA EXPLOSION-PROOF TO CLASS I DIVISION 1 GROUPS C&D T4 RATING

CHART 'C'

THREE PHASE 460-575 VOLT AC (orange molded plug)	
Power Cable	Motor Lead ID
Green (Ground)	Green
Black	1
Red	2
White	3
Jumpered Inside Cord Automatically (No user jump-ering required)	T4 & T7 Together T5 & T8 Together T6 & T9 Together

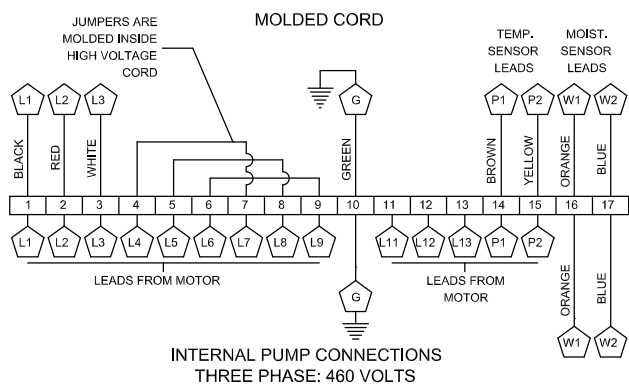

MOISTURE AND TEMPERATURE SENSORS	
Power Cable	Lead ID
Brown	P1 (Temperature Sensor)
Yellow	P2 (Temperature Sensor)
Orange	W1 (Moisture Sensor)
Blue	W2 (Moisture Sensor)

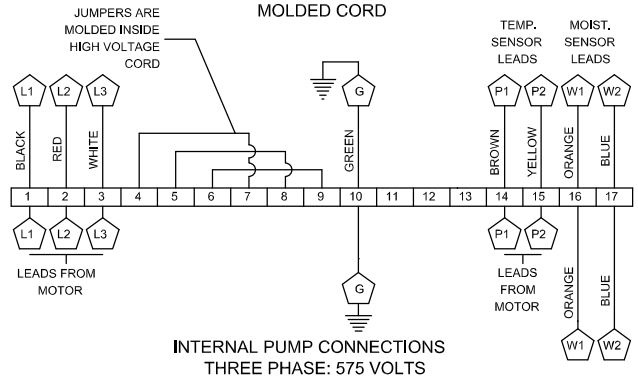

THREE PHASE 208-230 VOLT AC (black molded plug)	
Power Cable	Motor Lead ID
Green (Ground)	Green
Black	1
Red	2
White	3
Jumpered Inside Cord Automatically (No user jump-ering required)	T4, T5 & T6 Together T11 & T7 Together T13 & T9 Together T12 & T8 Together

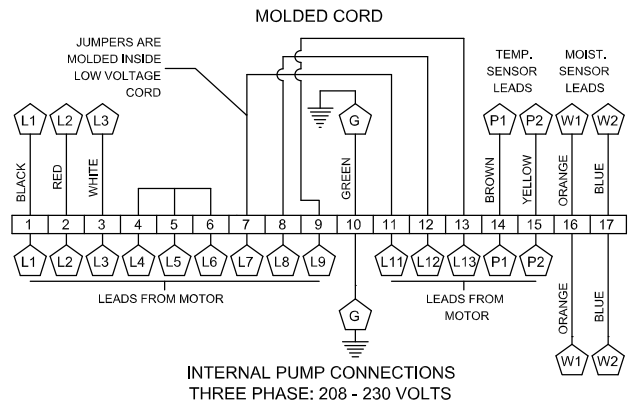

SINGLE PHASE 208-230 VOLT AC (black molded plug)	
Power Cable	Motor Lead ID
Green (Ground)	Green
Black	1 (Run)
Red	2 (Start)
White	3 (Common)
Jumpered Inside Cord Automatically (No user jump-ering required)	T4, T5 & T6 Together T11 & T7 Together T13 & T9 Together T12 & T8 Together

* Requires Start/Run Caps and Start Relay in panel *

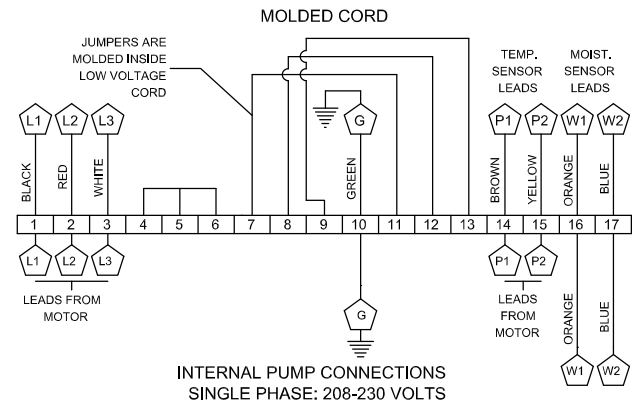

FIGURE 3

External Ground Note:

(Grd symbol) An external ground screw is provided on the side of the motor cap which can be used for supplemental bonding connection where local codes permit or require such connection.

TYPICAL POWER CIRCUIT

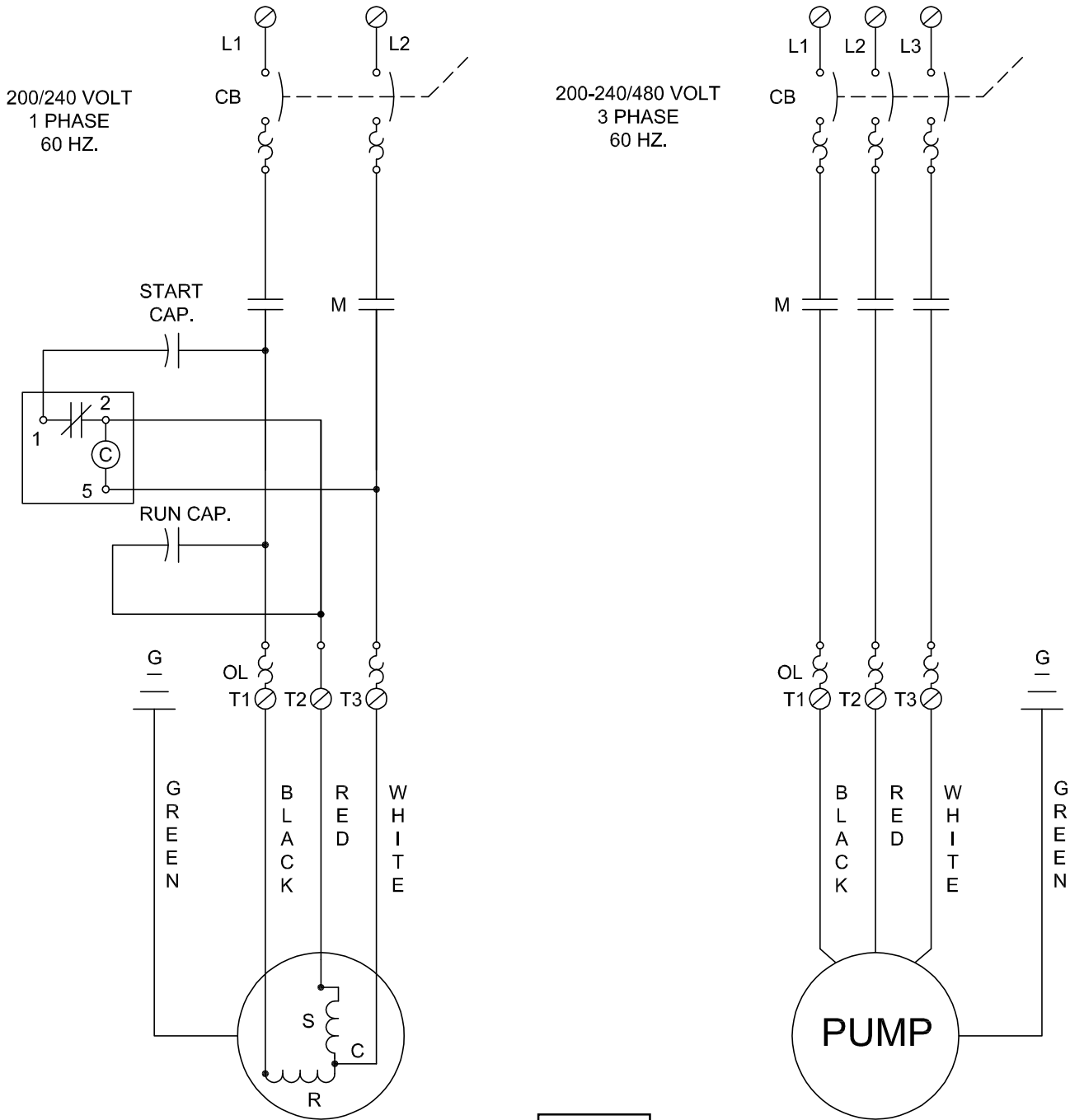

FIGURE 3b

Single Phase Cap Chart					
HP	RPM	Cap Kit	Start Relay	Start Cap	Run Cap
5	1750	133042	Mars 64	440MFD @ 330V	50MFD @370V
5	3450	141361	Mars 64	297MFD @ 330V	40MFD @440V
3	1750				
2	1750				

Single Phase Start Components

TYPICAL THERMAL PROTECTION WIRING DIAGRAM

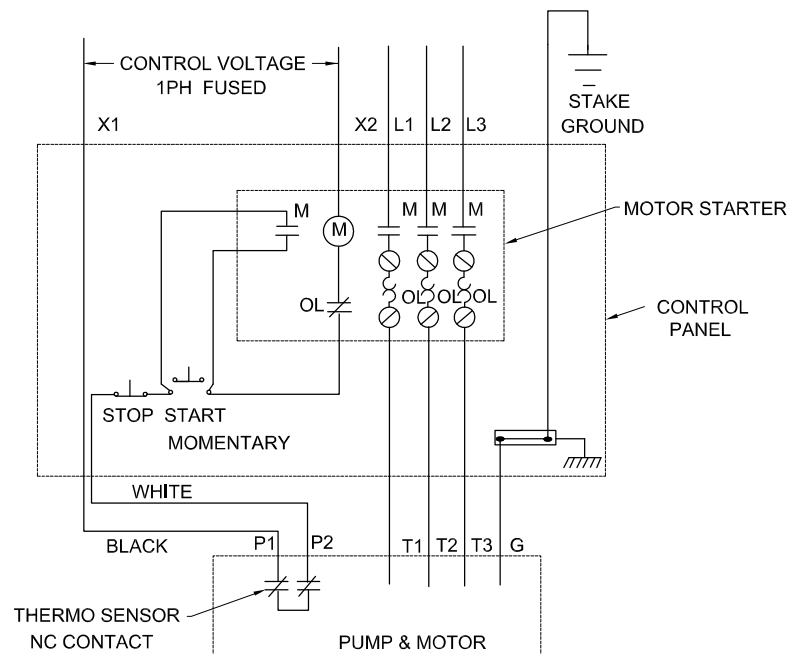

FIGURE 4

B-4.3) Overload Protection:

Current sensing overloads must be provided in the pump control panel and should be properly sized for the full load current of the pump. Three normally closed (N/C) thermal sensors wired in series (one per phase) are embedded in the motor windings and will detect excessive heat in the event an overload condition occurs which will then trip and stop the pump when wired in series with the pump contactor control circuit. The thermal sensor leads marked P1 and P2 **MUST** be connected in series with the stop button of the pilot circuit of the magnetic motor controller located in the control panel so that the thermostat will open the circuit before dangerous temperatures are reached. A manual momentary start switch is required to prevent the automatic restarting of the motor when the thermostat resets. For a typical wiring diagram, refer to Figure 4.

In the event of an over temperature condition, the source of this condition should be determined and rectified before the pump is put back into normal operation. **DO NOT LET THE PUMP CYCLE OR RUN IF AN OVER TEMPERATURE CONDITION OCCURS!**

If current through the temperature sensor exceeds the values listed, an intermediate control circuit relay must be used to reduce the current or the sensor will not work properly.

TEMPERATURE SENSOR ELECTRICAL RATINGS		
Volts	Continuous Amperes	Inrush Amperes
110-120	3.00	20.0
220-240	2.00	18.0

B-4.4) Moisture Sensors:

A normally open (N/O) detector is installed in the pump seal chamber, which will detect any moisture present, and a continuity test resistor built into the motor. The test resistor is rated 1 watt at 330K ohms. The moisture sensors **MUST** be connected to moisture detector control in the control panel which includes a continuity test circuit, see Figure 4 for typical wiring diagram. The normally closed (N/C) contact of the moisture detector **MUST** be connected in series with the stop button of the pilot circuit of the magnetic motor controller. Wiring must be provided from the moisture detector sensor probe leads of the motor designated W1 and W2 to terminals 9 and 10 of the 2800-XXX control. Terminal pair 1-2 must be continuously energized from an A-C supply line of electrical characteristics shown on the data table. In the event of moisture detection, the pump should be pulled and the source of the failure located and repaired. **IF MOISTURE DETECTION HAS OCCURRED, SCHEDULE MAINTENANCE AS SOON AS POSSIBLE !**

B-4.5) Control Panel and Electrical System:

The control panel and the electrical system **MUST** be properly designed and wired to include at least, but not limited to the following;

- Proper grounding per NEC.
- A temperature sensing circuit (See Fig. 4)
- A moisture detection circuit with continuity test circuit (See Fig. 5)
- A level control system.
- A main power manual disconnect and lock out.
- A motor starter and overload system.
- Start Capacitor, Run Capacitor & Start Relay (single phase only).

TYPICAL WIRING DIAGRAM FOR MOISTURE SENSOR RELAY

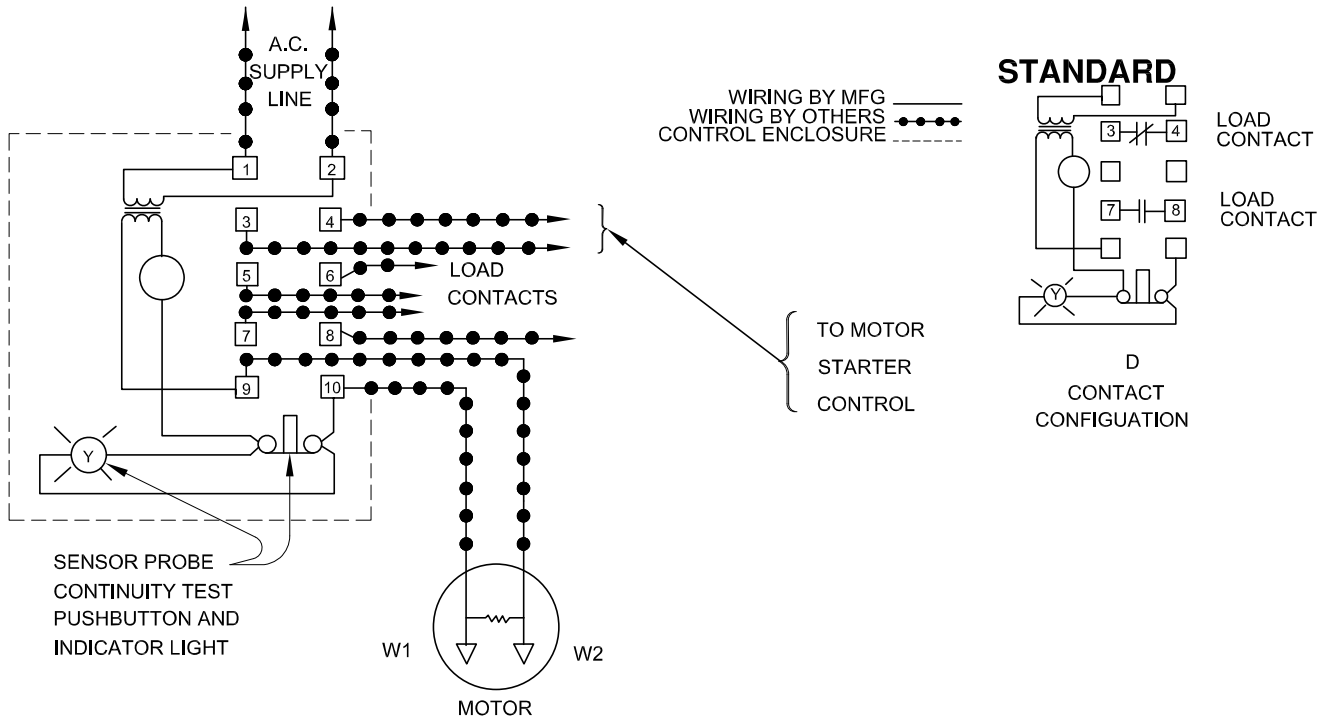

FIGURE 5

B-5) When Used with a Variable Speed Drive:

Maximum turndown should not exceed 2:1. Drive should be set to operate in constant torque mode.

It is advisable that all three phase control panels be purchased from the factory.

SECTION: C START-UP OPERATION

C-1) Check Voltage and Phase:

Before operating pump, compare the voltage and phase information stamped on the pump's identification plate to the available power.

C-2) Check Pump Rotation:

Before putting pump into service for the first time, the motor rotation must be checked. Improper motor rotation can result in poor pump performance and can damage the motor and/or pump. To check the rotation, suspend the pump freely, momentarily apply power and observe the "kickback". "Kickback" should always be in a counter-clockwise direction as viewed from the top of the pump motor housing and will always be in the opposite direction of the rotation arrows cast in the pump volute.

C-2.1) Incorrect Rotation for Three-Phase Pumps:

In the event that the rotation is incorrect for a three-phase installation, interchange any two power cable leads at the control box. Recheck the "kickback" rotation again by momentarily applying power.

C-2.2) Test Procedure For Moisture Sensor Control:

With a moisture detection control, a normally closed push button and neon indicating lamp is typically provided as a means of checking the moisture sensing components. When the push button is depressed, the indicating lamp will be illuminated to indicate (A) power is supplied to the control, (B) the control is operative, and (C) wiring to the moisture sensing probes in the motor is intact. This procedure should be performed periodically to confirm integrity of the circuit.

C-3) Start-Up Report:

Included at the end of this manual is one start-up report sheet, this sheet is to be completed as applicable. Return a copy to Deming and store the second in the control panel or with the pump manual. It is important to record this data at initial start-up since it will be useful to refer to should servicing the pump be required in the future.

C-3.1) Identification Plate:

Record the numbers from the pump's identification plate on the START-UP REPORT provided at the end of the manual for future reference.

C-3.2) Insulation Test:

Before the pump is put into service, an insulation (megger) test should be performed on the motor. The resistance values (ohms) as well as the voltage (volts) and current (amps) should be recorded on the start-up report. Pumps/systems with an insulation value of less than 5 M-Ohms should be investigated for moisture or damaged cables before proceeding.

C-3.3) Pump-Down Test:

After the pump has been properly wired and lowered into the basin, sump or lift station, it is advisable to check the system by filling with liquid and allowing the pump to operate through it's pumping cycle. The time needed to empty the system, or pump-down time along with the volume of water, should be recorded on the start-up report.

IMPORTANT! THE MAXIMUM ALLOWABLE STARTS PER HOUR IS 15, EVENLY SPACED.

SECTION D: PREVENTATIVE MAINTENANCE

As the motor and seal chamber are oil-filled, no lubrication or other maintenance is required, and generally Deming Pumps will give very reliable service and can be expected to operate for years of normal sewage pumping without failing. However, as with any mechanical piece of equipment a preventive maintenance program is recommended and suggested to include the following checks:

- 1) Test moisture detector control "Test Switch" for continuity of circuit. Water in the seal chamber will energize a seal leak warning light at the control panel. This is a warning light only and does not stop the motor. It indicates the seal has leaked and must be repaired. This should be done within 2 or 3 weeks to prevent further damage. See section C-2.2.
- 2) Inspect impeller and body for excessive buildup or clogging and repair as required per section E-2.
- 3) Inspect outer shaft seal and replace as required per section E-3.
- 4) Check motor for ground leakage and proper amp draw.

SECTION E: SERVICE AND REPAIR

NOTE: All item numbers in () refer to Figures 9 & 10.

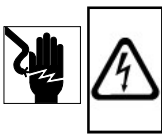

WARNING ! - Electrical power to the pump motors must be disconnected and locked out to prevent any dangerous electrical hazards or personnel danger before any service work is done to the pump.



CAUTION ! - Operating pump builds up heat and pressure; allow time for pump to cool to room temperature before handling or servicing.

E-1) Lubrication

E-1.1) Checking Oil

1. Place pump on it's side, and drain oil into a clean, dry container.
2. Check oil for contamination using an oil tester with a range to 30 Kilovolts breakdown.
3. If oil is found to be clean and uncontaminated (measure above 15 KV. breakdown), refill the seal chamber as per section E-1.2.
4. If oil is found to be dirty or contaminated (or measures below 15 KV. breakdown), the pump must be carefully inspected for leaks at the shaft seal (4), before refilling with oil. To locate the leak, perform a pressure test as per section E-1.3. After leak is repaired, refill with new oil as per section E-1.2.

E-1.2) Replacing Oil:

Seal Chamber - Drain all oil from seal chamber and dispose of properly. Refill with (see parts list for amount) (Oil amount for seal chamber for 18 frame pumps = 47oz. +/- 1 oz.) new cooling oil as per Table 1. An air space must remain to compensate for oil expansion (See Fig. 9). Set unit on side and fill.



IMPORTANT! - Do not overfill oil. Overfilling of seal chamber with oil can create excessive and dangerous hydraulic pressure which can destroy the pump and create a hazard. Overfilling oil voids warranty.

E-1.3) Pressure Test:

Seal Chamber - Before checking the pump for leaks around the shaft seal, the oil level should be full. Remove pipe plug. Apply pipe sealant to pressure gauge assembly and tighten into pipe plug hole. Pressurize motor housing to 10 P.S.I. Use a soap solution around the sealed area and inspect joints for "air bubbles". If, after five minutes, the pressure is still holding constant, and no "bubbles" are observed, slowly bleed the pressure and remove the gauge assembly. Replace the pipe plug using a sealant. If the pressure does not hold, then the leak must be located.



CAUTION! - Pressure builds up extremely fast, increase pressure by "tapping" air nozzle. Too much pressure will damage seal. Do Not exceed 10 P.S.I. in seal chamber.

TABLE 1 - COOLING OIL - Dielectric	
SUPPLIER	GRADE
BP	Enerpar SE100
Conoco	Pale Paraffin 22
Mobil	D.T.E. Oil Light
G & G Oil	Circulating 22
Imperial Oil	Voltesso-35
Shell Canada	Transformer-10
Texaco	Diala-Oil-AX
Woco	Premium 100

E-2) Impeller and Volute Service:

E-2.1) Disassembly and Inspection:

To clean out the volute (11), or clean out or replace impeller (6), disconnect power, remove cap screws (2) then vertically lift motor assembly from the pump body (11). Clean out the volute, if necessary, clean and examine impeller (6) for pitting or wear, replace if required. To remove Impeller (6), remove cap screw (8) and washer (8A). The impeller is keyed onto the shaft with a square key (7) and to remove, pull impeller straight off the shaft using a wheel puller if required. Inspect o-ring (9) and replace if cut or damaged. Before reinstallation, check the motor shaft and impeller bore for damage.

E-2.2) Reassembly:

To install impeller (6), apply a thin film of oil to motor shaft and slide impeller straight onto shaft, keeping keyways lined up. Drive key (7) into keyway. Thread cap screw (8) and washer (8A) into shaft and torque to 45 ft. lbs. Rotate impeller to check for binding. Place o-ring (9) on seal plate pilot diameter lining up holes and install impeller and motor assembly onto volute (11). Loctite cap screws (2), insert into volute and motor assembly and torque to 35 ft. lbs. Check for free rotation of motor and impeller.

E-3) Outer Shaft Seal Service:



CAUTION ! - Handle seal parts with extreme care. DO NOT scratch or mar lapped surfaces.

E-3.1) Disassembly and Inspection:

To expose outer shaft seal (4) for examination, remove Impeller and Volute per Section E-2.1. Set motor assembly (1) in the inverted position to prevent loss of oil. Remove snap ring from motor shaft, then retaining ring (5), spring (4C) and rotating member (4B) from shaft, See Figure 6. Examine all seal parts and especially contact faces. Inspect seal for signs of wear such as uneven wear pattern on stationary members, chips and scratches on either seal face. **DO NOT** interchange seal components, replace the entire shaft seal (4). If replacing seal, remove stationary (4A) from mounting plate by prying out with flat screw driver.

E-3.2) Reassembly:

Lightly oil (**DO NOT use grease**) outer surface of stationary member (4A). Press stationary member (4A) firmly into mounting plate using a seal pusher but the seal pusher is to come in contact with seal face (See Fig. 7).

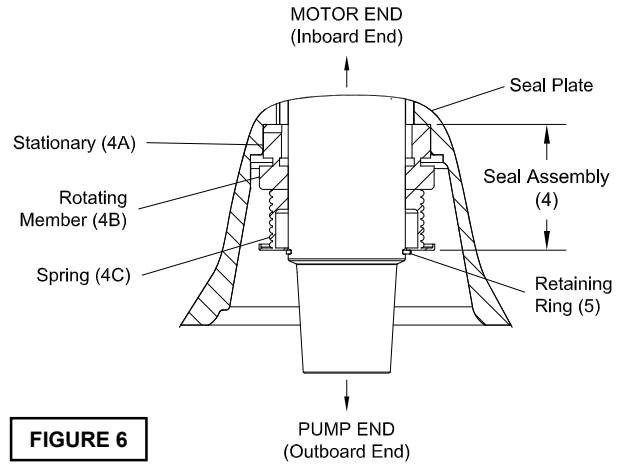

FIGURE 6

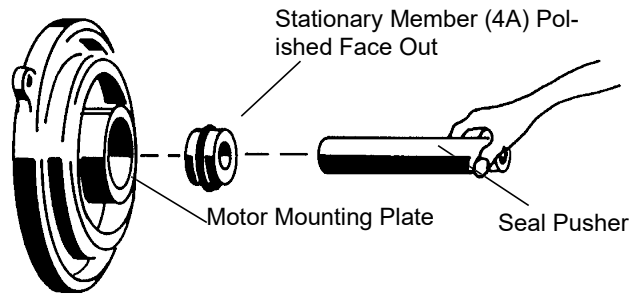

FIGURE 7

Make sure the stationary member is in straight and that the rubber ring is not out of it's groove. Lightly oil (**DO NOT use grease**) shaft and inner surface of bellows on rotating member (4B) see Figure 8. With lapped surface of rotating member (4B) facing inward toward stationary member (4A), slide rotating member (4B) onto shaft using a seal pusher, until lapped faces of (4A) and (4B) are together. (See Fig. 8).

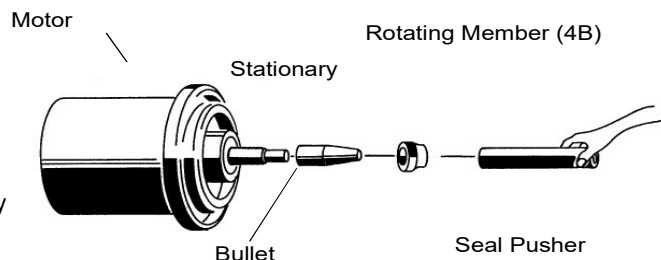

FIGURE 8



IMPORTANT ! - It is extremely important to keep seal faces clean during assembly. dirt particles lodged between these faces will cause the seal to leak.

Place spring (4C) over shaft and in place on rotating member (4B), making sure it is seated on retainer and not cocked or resting on bellows tail. Slide retaining ring (5) over shaft and let rest on spring (4C). Replace snap ring onto motor shaft. Inspect gasket (9) and replace if cut or damaged. Assemble impeller and volute as outlined in paragraph E-2.2.

SECTION: F REPLACEMENT PARTS

F-1 ORDERING REPLACEMENT PARTS:

When ordering replacement parts, ALWAYS furnish the following information:

1. Pump serial number and date code. (Paragraph F-4)
2. Pump model number. (Paragraph F-3)
3. Pump part number. (Paragraph F-2)
4. Part description.
5. Item part number.
6. Quantity required.
7. Shipping instructions.
8. Billing Instructions.

F-2 PART NUMBER:

This number is used for ordering and obtaining information.

F-3 MODEL NUMBER:

This designation consists of numbers and letters which represent the discharge size, series, horsepower, motor phase and voltage, speed and pump design. This number is used for ordering and obtaining information.

F-4 SERIAL NUMBER:

The serial number block will consist of a six digit number, which is specific to each pump and may be preceded by an alpha character, which indicates the plant location. This number will also be suffixed with a four digit number, which indicates the date the unit was built (Date Code).

EXAMPLE: A012345 0490.

Reference the six digit portion (Serial Number) of this number when referring to the product.

CRANE		<small>PUMPS & SYSTEMS</small>		DEMING®	
Power		Ph.	RPM	Volts	
Hz.	FLA.		SFA	SF	
Ambient 0-40°C	Duty CONT.	Code	Weight	Part No.	
Model No.		Serial No.		Imp. Dia.	

- THERMALLY PROTECTED - CONNECT THERMAL CONTACTS
 - SUBMERSIBLE TO 66 FT - SUBMERSIBLE SEWAGE PUMP - INSUL. CL.: F
 - CLASS I DIV.1 GROUP C AND D HAZARDOUS LOCATIONS - TEMP CODE: T4

WARNING

1. A.) SEE INSTRUCTION MANUAL FOR: PROPER INSTALLATION, CORD REPLACEMENT, MOISTURE SENSOR AND THERMAL CUTOFF WIRING REQUIREMENTS. B.) PUMP MUST BE PROPERLY GROUNDED IN ACCORDANCE WITH THE NATIONAL ELECTRICAL CODE AND ALL LOCAL CODES. C.) DISCONNECT THE PUMP FROM THE POWER SOURCE BEFORE HANDLING OR SERVICING. D.) INSTALLATION AND SERVICE SHALL BE CONDUCTED BY A QUALIFIED PERSON.

2. USE WITH APPROVED MOTOR CONTROL THAT MATCHES MOTOR INPUT IN FULL LOAD AMPERES WITH OVERLOAD ELEMENT(S) SELECTED OR ADJUSTED IN ACCORDANCE WITH CONTROL INSTRUCTIONS. (UTILISER UN DÉMARREUR APPROUVÉ CONVENANT AU COURANT À PLEINE CHARGE DU MOTEUR ET DONT LES ÉLÉMENTS THERMIQUES SONT RÉGLÉS OU CHOISIS CONFORMÉMENT AUX INSTRUCTION QUI L'ACCOMPAGNENT).

3. KEEP CLEAR OF SUCTION AND DISCHARGE OPENING AT ALL TIMES WHEN POWER IS CONNECTED.

4. MOTOR HOUSING WILL CONTAIN HOT OIL UNDER PRESSURE, ALLOW MOTOR TO COOL BEFORE OPENING.

5. THIS PUMP IS NOT INTENDED FOR USE IN SWIMMING POOLS, DECORATIVE FOUNTAINS OR INSTALLATIONS IN WHICH HUMAN CONTACT WITH THE PUMPED MEDIA IS A COMMON OCCURRENCE.

6. DO NOT REMOVE CORD AND STRAIN RELIEF. CSA 108
 7. DO NOT CONNECT CONDUIT TO PUMP. LR16667
 8. DO NOT PUMP FLAMMABLE LIQUIDS
 9. NOT SUITABLE FOR ENVIRONMENTS CONTAINING GASOLINE OR HEXANE.

127265A

TROUBLE SHOOTING

CAUTION ! Always disconnect the pump from the electrical power source before handling.
 If the system fails to operate properly, carefully read instructions and perform maintenance recommendations.
 If operating problems persist, the following chart may be of assistance in identifying and correcting them:
MATCH “CAUSE” NUMBER WITH CORRELATING “CORRECTION” NUMBER.

NOTE: Not all problems and corrections will apply to each pump model.

PROBLEM	CAUSE	CORRECTION
Pump will not run	<ol style="list-style-type: none"> 1. Poor electrical connection, blown fuse, tripped breaker or other interruption of power, improper power supply. 2. Motor or switch inoperative (to isolate cause, go to manual operation of pump). <ol style="list-style-type: none"> 2a. Float movement restricted. 2b. Switch will not activate pump or is defective. 2c. Defective motor 3. Insufficient liquid level. 	<ol style="list-style-type: none"> 1. Check all electrical connections for security. Have electrician measure current in motor leads, if current is within $\pm 20\%$ of locked rotor Amps, impeller is probably locked. If current is 0, overload may be tripped. Remove power, allow pump to cool, then recheck current. 2a. Reposition pump or clean basin as required to provide adequate clearance for float.
Pump will not turn off	<ol style="list-style-type: none"> 2a. Float movement restricted. 2b. Switch will not activate pump or is defective. 4. Excessive inflow or pump not properly sized for application. 9. Pump may be airlocked 14. H-O-A switch on panel is in “HAND” position 	<ol style="list-style-type: none"> 2b. Disconnect level control. Set ohmmeter for a low range, such as 100 ohms full scale and connect to level control leads. Actuate level control manually and check to see that ohmmeter shows zero ohms for closed switch and full scale for open switch. (Float Switch). 2c. Check winding insulation (Megger Test) and winding resistance. If check is outside of range, dry and recheck. If still defective, replace per service instructions.
Pump hums but does not run	<ol style="list-style-type: none"> 1. Incorrect voltage 8. Impeller jammed or loose on shaft, worn or damaged, impeller cavity or inlet plugged. 	<ol style="list-style-type: none"> 2c. Check winding insulation (Megger Test) and winding resistance. If check is outside of range, dry and recheck. If still defective, replace per service instructions.
Pump delivers insufficient capacity	<ol style="list-style-type: none"> 1. Incorrect voltage. 4. Excessive inflow or pump not properly sized for application. 5. Discharge restricted. 6. Check valve stuck closed or installed backwards. 7. Shut-off valve closed. 8. Impeller jammed or loose on shaft, worn or damaged, impeller cavity or inlet plugged. 9. Pump may be airlocked. 10. Pump running backwards 	<ol style="list-style-type: none"> 3. Make sure liquid level is at least equal to suggested turn-on point. 4. Recheck all sizing calculations to determine proper pump size. 5. Check discharge line for restrictions, including ice if line passes through or into cold areas. 6. Remove and examine check valve for proper installation and freedom of operation. 7. Open valve.
Pump cycles too frequently or runs periodically when fixtures are not in use	<ol style="list-style-type: none"> 6. Check valve stuck closed or installed backwards. 11. Fixtures are leaking. 15. Ground water entering basin. 	<ol style="list-style-type: none"> 8. Check impeller for freedom of operation, security and condition. Clean impeller and inlet of any obstruction. 9. Loosen union slightly to allow trapped air to escape. Verify that turn-off level of switch is set so that the suction is always flooded. Clean vent hole.
Pump shuts off and turns on independent of switch, (trips thermal overload protector). CAUTION! Pump may start unexpectedly. Disconnect power supply.	<ol style="list-style-type: none"> 1. Incorrect voltage. 4. Excessive inflow or pump not properly sized for application. 8. Impeller jammed, loose on shaft, worn or damaged, impeller cavity or inlet plugged. 12. Excessive water temperature. (internal protection only) 	<ol style="list-style-type: none"> 10. Check rotation. If power supply is three phase, reverse any two of three power supply leads to ensure proper impeller rotation.. 11. Repair fixtures as required to eliminate leakage.
Pump operates noisily or vibrates excessively	<ol style="list-style-type: none"> 2c. Worn bearings, motor shaft bent. 5. Debris in impeller cavity or broken impeller 10. Pump running backwards 13. Piping attachments to building structure too rigid or too loose. 	<ol style="list-style-type: none"> 12. Check pump temperature limits & fluid temperature. 13. Replace portion of discharge pipe with flexible connector. 14. Turn to automatic position. 15. Check for leaks around basin inlet and outlets.

Cross Section

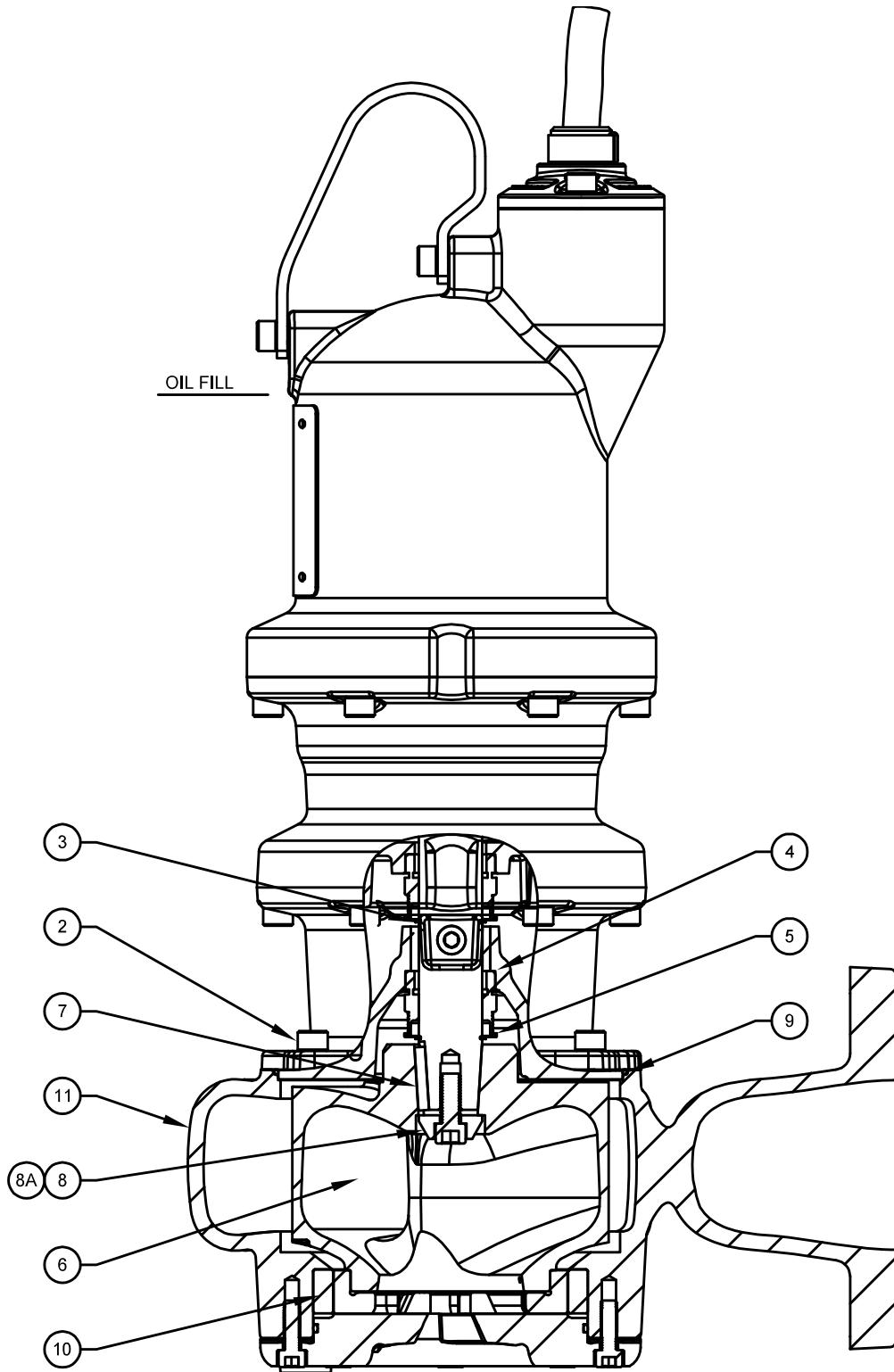
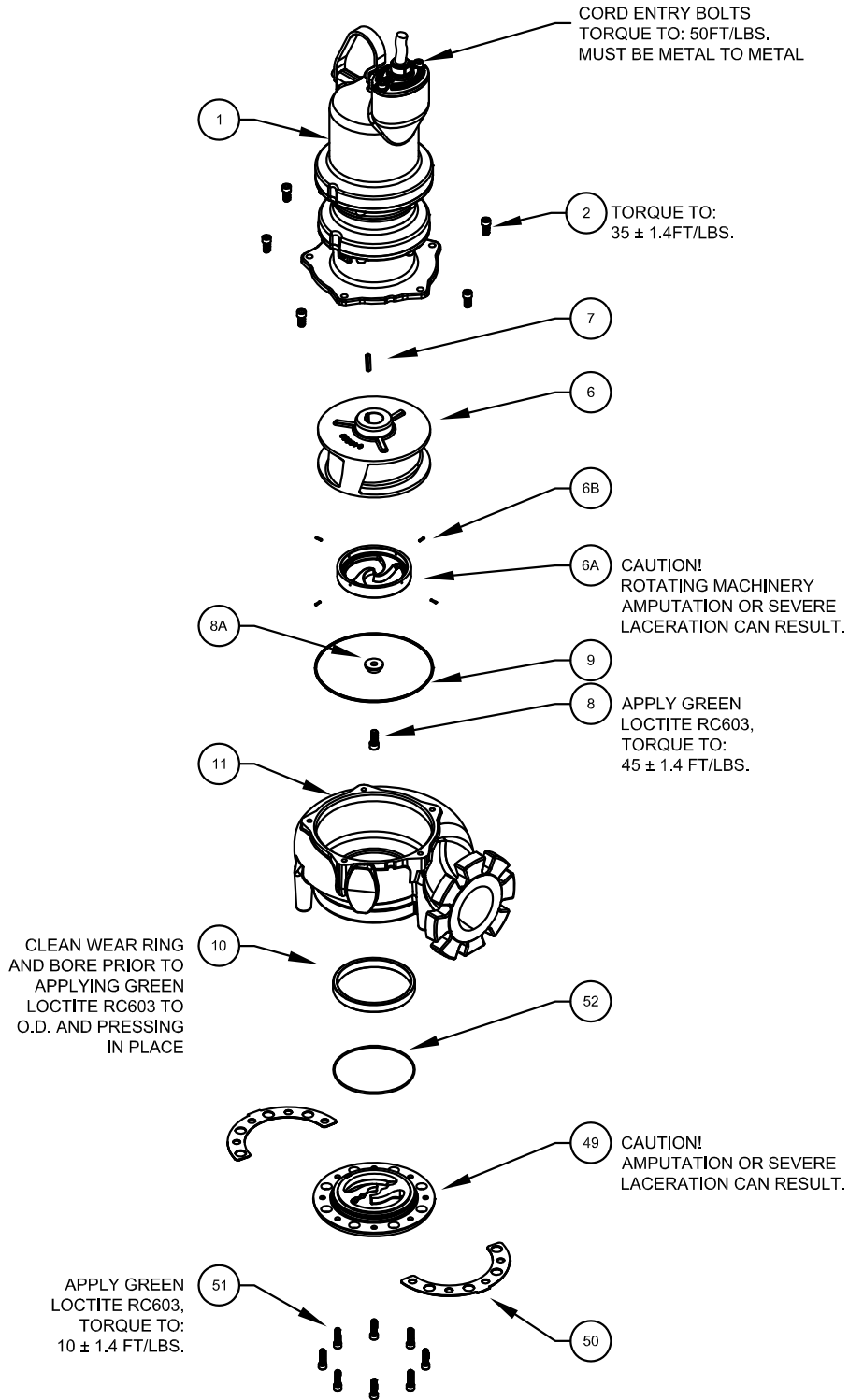

FIGURE 9

Exploded View



WARNING!
OVERTIGHTENING OF BOLTS WILL LEAD TO DEFORMATION OF THE STRIKER PLATE AND AN INCREASE OF THE CUTTING SURFACE CLEARANCE.

ITEMS NOT SHOWN: 4, 41, 42

FIGURE 10

PARTS LIST

O-Ring Kit.....	138580-XP	(+)	5, 9
Seal Kit	See Table on Page 25		
Hardware Kit	138615-D	(♦)	2, 7, 8, 8A
Volute Kit.....	See Table on Page 20	(■)	10, 11, 41, 42
Cord Attachment Kit.....	140152-18	(π)	2
Lifting Handle Kit.....	133032-D-KIT	(>)	2, 23
Leg Kit	See Table on Page 25		
Slicer Blade Attachement Kit	138614D	(○)	7, 8, 8A
Slicer Blade Kit	See Table on Page 23	(∂)	6, 6A, 6B
Shim Kit.....	See Table on Page 21	(Δ)	50
Striker Plate Kit.....	See Table on Page 21	(Σ)	49, 50, 51, 52
Striker Shell Kit.....	See Table on Page 21	(△)	10, 11, 41, 42, 49, 50, 51, 52
Striker Hardware Kit.....	See Table on Page 21	(∩)	51, 52
Striker O-Ring Stock Kit.....	See Table on Page 21	(▲)	52

ITEM	QTY	PART NO.	DESCRIPTION	MATERIAL	
1	1	-	No Resale	Driver Assembly	
2	6	127223	♦ π>	Screw, SHCS, M12 x 1.75 x 25	18-8 SS
4	1	See Table		Seal, Mechanical, Lower	
5	2	133048	+	Ring, Retaining, EXT, 5100	420 SS
6		See Table		Impeller	Ductile Iron
6A	1	See Table		Slicer Blade	Stainless 440C
6B	4	See Table		Slicer Pins	Stainless 400
7	1	Q21-20-J8	♦ ○	Key, ¼ x ¼ x 1½"	303 SS
8	1	136284	♦ ○	Screw, SHCS, M12 x 1.75 x 30	18-8 SS
8A	1	136233	♦ ○	Washer, Impeller, .50 x 1.50	18-8 SS
9		See Table	+	O-Ring (Volute)	Buna-N
10		See Table	■ △	Wear Ring (Volute)	Bronze
11		See Table	■ △	Volute	Cast Iron
23	1	133032	>	Handle, Lifting	304 Stainless Steel
41	5oz	125502	■ △	Paint, Epoxy, Part A	Epoxy
42	5oz	125503	■ △	Paint, Epoxy, Part B	Epoxy
49	1	See Table	Σ△	Striker Plate	Stainless 440C
50	*	See Table	ΔΣ△	Shims	Plastic
51	8	143110	Σ△∩	Screw, SHCS, M10 x 1.5 x 35	Stainless
	8	131147	Σ△∩	Screw, SHCS, M10 x 1.5 x 35	(DG Model ONLY)
52	1	See Table	Σ△∩▲	O-Ring, Buna-N, 70 Duro	Buna-N

*NOTE: Quantity dependent on Blade clearance, nominal is 0.09 Shim Stack, with 0.003 gap between Blade and Plate.

Power Cable Chart					
Part No.	Length (feet)	Volt	Max. Amps	CORD SIZE	CORD O.D. +/- .02in (.5mm)
125496XC	30	208-240	31.7	12/4 - 18/4	0.86in (22.0mm)
125496XF	50	208-240	31.7	12/4 - 18/4	0.86in (22.0mm)
125496XJ	75	208-240	31.7	12/4 - 18/4	0.86in (22.0mm)
125496XL	100	208-240	31.7	12/4 - 18/4	0.86in (22.0mm)
125497XC	30	400-600	31.7	12/4 - 18/4	0.86in (22.0mm)
125497XF	50	400-600	31.7	12/4 - 18/4	0.86in (22.0mm)
125497XJ	75	400-600	31.7	12/4 - 18/4	0.86in (22.0mm)
125497XL	100	400-600	31.7	12/4 - 18/4	0.86in (22.0mm)
125498XC	30	208-240	59.0	8/4 - 18/4	1.12in (28.4mm)
125498XF	50	208-240	59.0	8/4 - 18/4	1.12in (28.4mm)
125498XJ	75	208-240	59.0	8/4 - 18/4	1.12in (28.4mm)
125498XL	100	208-240	59.0	8/4 - 18/4	1.12in (28.4mm)
125499XC	30	400-600	59.0	8/4 - 18/4	1.12in (28.4mm)
125499XF	50	400-600	59.0	8/4 - 18/4	1.12in (28.4mm)
125499XJ	75	400-600	59.0	8/4 - 18/4	1.12in (28.4mm)
125499XL	100	400-600	59.0	8/4 - 18/4	1.12in (28.4mm)

Note: 1 - Standard Motor includes, Moisture & Temperature Sensors
and Carbon/Ceramic/Buna-N Inner & Silicon Carbide/Silicon Carbide/ Buna-N Outer Shift Seals.
Note: 2 - Item 4 is for Outer seal replacement **ONLY**.

Volute Pilot Diameter					
Model	Volute Size	Volute P/N *	Volute Kit P/N	Volute Wear Ring P/N *	O-Ring P/N *
3MA	208mm	143127S	143127SK-D-KIT	143112	125857-200
4M	208mm	133033S	133033SK-D-KIT	133045	125857-200
4ML	240mm	129994S	129994S4K-4D-KIT	129996	125857-235
4MM	305mm	Not Available in 18 Frame			
4MB	370mm				
4MH	370mm				
4MHA	370mm				
4D	208mm	133033S	133033SK-D-KIT	133045	125857-200
4DM	240mm	129994S	129994S4K-5D-KIT	129997	125857-235
4DH	370mm	Not Available in 18 Frame			
6ML	370mm				
6MM	370mm				
6MH	370mm				
6DL	305mm				
6D	370mm				

* **NOTE:** Listed for Reference Only. Must purchase as a kit.

Striker Kits									
Model	Plate Flange Size	Striker Shell Kit	Striker Plate Kit	Shim Kit	Striker Hardware Kit	Kit Component Info (Ref. ONLY)			
						Striker Plate	Striker Plate O-Ring	Striker Plate Shims	
3MA	4 INCH	143127SK-ASSY-KIT	142125D-ASSY-KIT	142157D-KIT	142633-4D-KIT	142125	142174-259	142157-002 (RED) 142157-004 (TAN) 142157-010 (BROWN) 142157-025 (WHITE) 142157-060 (CLEAR)	
4ML	4 INCH	129994SK-4D-ASSY-KIT							
4MM	4 INCH	Not Available in 18 Frame	Not Available in 18 Frame	Not Available in 18 Frame	Not Available in 18 Frame	Not Available in 18 Frame	Not Available in 18 Frame	Not Available in 18 Frame	
4MB	4 INCH								
4MH	4 INCH								
4DH	4 INCH								
4MHA	4 INCH								
4M	4 INCH								
4D	4 INCH	133033SK-D-ASSY-KIT	142137D-ASSY-KIT	142157D-KIT	142633-4D-KIT	142137	142174-259	141579-002 (RED) 141579-004 (TAN)	
4DM	5 INCH	129994SK-5D-ASSY-KIT	141601D-ASSY-KIT	141579D-KIT	142633-5D-KIT	141601	142174-260	141579-010 (BROWN) 141579-025 (WHITE) 141579-060 (CLEAR)"	
6ML	6 INCH	Not Available in 18 Frame	Not Available in 18 Frame	Not Available in 18 Frame	Not Available in 18 Frame	Not Available in 18 Frame	Not Available in 18 Frame	Not Available in 18 Frame	
6MM	6 INCH								
6MH	6 INCH								
6DL	6 INCH								
6D	6 INCH								

Model	Striker Plate Flange Size	Striker O-ring Stock Kit	Shim Stock Kit	Spacing Kit
3MA	4 INCH	142635D	142157D-STK-KIT	142634D
4ML	4 INCH			
4MM	4 INCH	Not Available in 18 Frame	Not Available in 18 Frame	Not Available in 18 Frame
4MB	4 INCH			
4MH	4 INCH			
4DH	4 INCH			
4MHA	4 INCH			
4M	4 INCH			
4D	4 INCH	142635D	142157D-STK-KIT	142634D
4DM	5 INCH			
6ML	6 INCH	Not Available in 18 Frame	Not Available in 18 Frame	Not Available in 18 Frame
6MM	6 INCH			
6MH	6 INCH			
6DL	6 INCH			
6D	6 INCH			

Striker Plate Kit includes:
<ul style="list-style-type: none"> • Striker Plate • O-ring (Plate) • M10 Bolts (qty. 8) • Shim Kit

Striker Shell Kit includes:
<ul style="list-style-type: none"> • Striker Plate Kit • Volute Kit

Striker Hardware Kit includes:
<ul style="list-style-type: none"> • M10 Bolts (qty. 8) • O-ring (Plate)

Spacing Kit includes:
<ul style="list-style-type: none"> • Level 4 Cut Proof Gloves • Spacer Gage

Striker O-ring Stock Kit includes: *
<ul style="list-style-type: none"> • Small O-ring (4 inch Plate)(qty. 4) • Medium O-ring (5 inch Plate)(qty. 2) • Large O-ring (6 inch Plate)(qty. 4)

Shim Kit includes:
<ul style="list-style-type: none"> • 0.002" Shims (4) • 0.004" Shims (4) • 0.010" Shims (4) • 0.025" Shims (2) • 0.060" Shims (2) • Level 4 Cut Proof Gloves • Spacer Gage

Shim Stock Kit includes:
<ul style="list-style-type: none"> • 0.002" Shims (12) • 0.004" Shims (12) • 0.010" Shims (12) • 0.025" Shims (8) • 0.060" Shims (6)

NOTE:
 *This kit includes sizes not applicable to 18 frame.

"4ML = C" Impeller						
Trim Dia. mm (in)	Ductile Iron Slicer Blade Kit	Nihard Slicer Blade Kit	Kit Component Info (Ref. ONLY)			
			Ductile Iron Part No.	Nihard Part No.	Blade	Pin
235mm (9.25in)	127263-ASSY-KIT	143276-ASSY-KIT	127263-C	143276-C	142124	142133-0750
230mm (9.06in)	127263TA-ASSY-KIT	143276TA-ASSY-KIT	127263TA-C	143276TA-C	142124	142133-0750
225mm (8.86in)	127263TB-ASSY-KIT	143276TB-ASSY-KIT	127263TB-C	143276TB-C	142124	142133-0750
220mm (8.66in)	127263TC-ASSY-KIT	143276TC-ASSY-KIT	127263TC-C	143276TC-C	142124	142133-0750
215mm (8.47in)	127263TD-ASSY-KIT	143276TD-ASSY-KIT	127263TD-C	143276TD-C	142124	142133-0750
210mm (8.27in)	127263TE-ASSY-KIT	143276TE-ASSY-KIT	127263TE-C	143276TE-C	142124	142133-0750
205mm (8.07in)	127263TF-ASSY-KIT	143276TF-ASSY-KIT	127263TF-C	143276TF-C	142124	142133-0750
200mm (7.87in)	127263TG-ASSY-KIT	143276TG-ASSY-KIT	127263TG-C	143276TG-C	142124	142133-0750
195mm (7.68in)	127263TH-ASSY-KIT	143276TH-ASSY-KIT	127263TH-C	143276TH-C	142124	142133-0750
190mm (7.48in)	127263TJ-ASSY-KIT	143276TJ-ASSY-KIT	127263TJ-C	143276TJ-C	142124	142133-0750
185mm (7.28in)	127263TK-ASSY-KIT	143276TK-ASSY-KIT	127263TK-C	143276TK-C	142124	142133-0750

"4D = F" Impeller						
Trim Dia. mm (in)	Ductile Iron Slicer Blade Kit	Nihard Slicer Blade Kit	Kit Component Info (Ref. ONLY)			
			Ductile Iron Part No.	Nihard Part No.	Blade	Pin
190mm (7.48in)	133052-ASSY-KIT	143277-ASSY-KIT	133052-C	143277-C	142136	142133-1000
185mm (7.28in)	133052TA-ASSY-KIT	143277TA-ASSY-KIT	133052TA-C	143277TA-C	142136	142133-1000
180mm (7.09in)	133052TB-ASSY-KIT	143277TB-ASSY-KIT	133052TB-C	143277TB-C	142136	142133-1000
175mm (6.89in)	133052TC-ASSY-KIT	143277TC-ASSY-KIT	133052TC-C	143277TC-C	142136	142133-1000
170mm (6.69in)	133052TD-ASSY-KIT	143277TD-ASSY-KIT	133052TD-C	143277TD-C	142136	142133-1000
165mm (6.50in)	133052TE-ASSY-KIT	143277TE-ASSY-KIT	133052TE-C	143277TE-C	142136	142133-1000
160mm (6.30in)	133052TF-ASSY-KIT	143277TF-ASSY-KIT	133052TF-C	143277TF-C	142136	142133-1000
155mm (6.10in)	133052TG-ASSY-KIT	143277TG-ASSY-KIT	133052TG-C	143277TG-C	142136	142133-1000
150mm (5.91in)	133052TH-ASSY-KIT	143277TH-ASSY-KIT	133052TH-C	143277TH-C	142136	142133-1000
145mm (5.71in)	133052TJ-ASSY-KIT	143277TJ-ASSY-KIT	133052TJ-C	143277TJ-C	142136	142133-1000
140mm (5.51in)	133052TK-ASSY-KIT	143277TK-ASSY-KIT	133052TK-C	143277TK-C	142136	142133-1000
135mm (5.31in)	133052TN-ASSY-KIT	143277TN-ASSY-KIT	133052TN-C	143277TN-C	142136	142133-1000
130mm (5.11in)	133052TL-ASSY-KIT	143277TL-ASSY-KIT	133052TL-C	143277TL-C	142136	142133-1000
125mm (4.92in)	133052TM-ASSY-KIT	143277TM-ASSY-KIT	133052TM-C	143277TM-C	142136	142133-1000

"4DM = G" Impeller						
Trim Dia. mm (in)	Ductile Iron Slicer Blade Kit	Nihard Slicer Blade Kit	Kit Component Info (Ref. ONLY)			
			Ductile Iron Part No.	Nihard Part No.	Blade	Pin
235mm (9.25in)	129991-ASSY-KIT	143204-ASSY-KIT	129991-C	143204-C	142131	142133-0562
230mm (9.06in)	129991TA-ASSY-KIT	143204TA-ASSY-KIT	129991TA-C	143204TA-C	142131	142133-0562
225mm (8.86in)	129991TB-ASSY-KIT	143204TB-ASSY-KIT	129991TB-C	143204TB-C	142131	142133-0562
220mm (8.66in)	129991TC-ASSY-KIT	143204TC-ASSY-KIT	129991TC-C	143204TC-C	142131	142133-0562
215mm (8.47in)	129991TD-ASSY-KIT	143204TD-ASSY-KIT	129991TD-C	143204TD-C	142131	142133-0562
210mm (8.27in)	129991TE-ASSY-KIT	143204TE-ASSY-KIT	129991TE-C	143204TE-C	142131	142133-0562
205mm (8.07in)	129991TF-ASSY-KIT	143204TF-ASSY-KIT	129991TF-C	143204TF-C	142131	142133-0562
200mm (7.87in)	129991TG-ASSY-KIT	143204TG-ASSY-KIT	129991TG-C	143204TG-C	142131	142133-0562
195mm (7.68in)	129991TH-ASSY-KIT	143204TH-ASSY-KIT	129991TH-C	143204TH-C	142131	142133-0562
190mm (7.48in)	129991TJ-ASSY-KIT	143204TJ-ASSY-KIT	129991TJ-C	143204TJ-C	142131	142133-0562
185mm (7.28in)	129991TK-ASSY-KIT	143204TK-ASSY-KIT	129991TK-C	143204TK-C	142131	142133-0562
180mm (7.09in)	129991TL-ASSY-KIT	143204TL-ASSY-KIT	129991TL-C	143204TL-C	142131	142133-0562
175mm (6.89in)	129991TM-ASSY-KIT	143204TM-ASSY-KIT	129991TM-C	143204TM-C	142131	142133-0562
170mm (6.69in)	129991TN-ASSY-KIT	143204TN-ASSY-KIT	129991TN-C	143204TN-C	142131	142133-0562
165mm (6.50in)	129991TP-ASSY-KIT	143204TP-ASSY-KIT	129991TP-C	143204TP-C	142131	142133-0562

"4M = S" Impeller						
Trim Dia. mm (in)	Ductile Iron Slicer Blade Kit	Nihard Slicer Blade Kit	Kit Component Info (Ref. ONLY)			
			Ductile Iron Part No.	Nihard Part No.	Blade	Pin
200mm (7.87in)	133044-ASSY-KIT	143287-ASSY-KIT	133044-C	143287-C	142136	142133-1000
195mm (7.68in)	133044TA-ASSY-KIT	143287TA-ASSY-KIT	133044TA-C	143287TA-C	142136	142133-1000
190mm (7.48in)	133044TB-ASSY-KIT	143287TB-ASSY-KIT	133044TB-C	143287TB-C	142136	142133-1000
185mm (7.28in)	133044TC-ASSY-KIT	143287TC-ASSY-KIT	133044TC-C	143287TC-C	142136	142133-1000
180mm (7.09in)	133044TD-ASSY-KIT	143287TD-ASSY-KIT	133044TD-C	143287TD-C	142136	142133-1000
175mm (6.89in)	133044TE-ASSY-KIT	143287TE-ASSY-KIT	133044TE-C	143287TE-C	142136	142133-1000
170mm (6.69in)	133044TF-ASSY-KIT	143287TF-ASSY-KIT	133044TF-C	143287TF-C	142136	142133-1000
165mm (6.50in)	133044TG-ASSY-KIT	143287TG-ASSY-KIT	133044TG-C	143287TG-C	142136	142133-1000
160mm (6.30in)	133044TH-ASSY-KIT	143287TH-ASSY-KIT	133044TH-C	143287TH-C	142136	142133-1000
155mm (6.10in)	133044TJ-ASSY-KIT	143287TJ-ASSY-KIT	133044TJ-C	143287TJ-C	142136	142133-1000

"3MA = PA" Impeller						
Trim Dia. mm (in)	Ductile Iron Slicer Blade Kit	Nihard Slicer Blade Kit	Kit Component Info (Ref. ONLY)			
			Ductile Iron Part No.	Nihard Part No.	Blade	Pin
205mm (8.07in)	137223-ASSY-KIT	143288-ASSY-KIT	137223-C	143288-C	142126	142133-0750
200mm (7.87in)	137223TA-ASSY-KIT	143288TA-ASSY-KIT	137223TA-C	143288TA-C	142126	142133-0750
195mm (7.68in)	137223TB-ASSY-KIT	143288TB-ASSY-KIT	137223TB-C	143288TB-C	142126	142133-0750
190mm (7.48in)	137223TC-ASSY-KIT	143288TC-ASSY-KIT	137223TC-C	143288TC-C	142126	142133-0750
185mm (7.28in)	137223TD-ASSY-KIT	143288TD-ASSY-KIT	137223TD-C	143288TD-C	142126	142133-0750
180mm (7.09in)	137223TE-ASSY-KIT	143288TE-ASSY-KIT	137223TE-C	143288TE-C	142126	142133-0750
175mm (6.89in)	137223TF-ASSY-KIT	143288TF-ASSY-KIT	137223TF-C	143288TF-C	142126	142133-0750
170mm (6.69in)	133044TG-ASSY-KIT	143288TG-ASSY-KIT	137223TG-C	143288TG-C	142126	142133-0750

Slicer Blade Kit includes:
<ul style="list-style-type: none"> • Impeller (Balanced, trimmed) • Blade (Pressed) • Attachment Pins (Pressed) <p><i>(Components are Fully Assembled)</i></p>

Slicer Blade Attachment Kit includes:
<ul style="list-style-type: none"> • Impeller Washer • Impeller Bolt • Impeller Key

Seal Kits		
Seal Kit Part No.	Seal Part No.	Seal Material
138580-DX-CC	133029	Carbon / Ceramic
138580-DX-SD (STD)	133029SD	Silicon Carbide / Silicon Carbide
138580-DX-TC	133029SB	Tungsten Carbide / Tungsten Carbide

Hardware Kit includes:
<ul style="list-style-type: none"> • Impeller key • Volute attachment screws • Impeller attachment screws

Cord Attachment Kit includes:
<ul style="list-style-type: none"> • Attachment screws

Seal Kit includes:
<ul style="list-style-type: none"> • Volute O-Ring (option 1) • Volute O-Ring (option 2) • Volute O-Ring (option 3) • Volute O-Ring (option 4) • External Retaining Ring • Lower Mechanical Seal

NOTE: Kit contains hardware your pump may not require.

O-Ring Kit includes:
<ul style="list-style-type: none"> • Volute O-Ring (option 1) • Volute O-Ring (option 2) • Volute O-Ring (option 3) • External Retaining Ring

NOTE: Kit contains hardware your pump may not require.

Volute Kit includes:
<ul style="list-style-type: none"> • Wear Ring (pressed) • Volute (painted)

Lifting Handle Kit includes:
<ul style="list-style-type: none"> • Lifting Handle • Attachment hardware

Additional Components			
Component	Part No.	Single Sale	Kit
Impeller	See Table	Yes	N/A
Wear Ring	See Table	Yes	Volute Kit, Shell Kit
Lifting Handle	133032	Yes	N/A
Nameplate	No Resale		
Nameplate/Model Plate Rivets	001628	No Resale	Rivet Kit (p/n 139398D)

Leg Kits		
Model	Leg Kit Part No.	Leg Kit Height Inches (mm)
3MA	125506	3.15 (80)
4M	125506	3.15 (80)
4D	125506	3.15 (80)
4ML	125506	3.15 (80)
4DM	125506	3.15 (80)
4MM	125506B	6.50 (165)
6DL	125506B	6.50 (165)
4MB	125506B	6.50 (165)
4MH	125506B	6.50 (165)
4MHA	125506B	6.50 (165)
4DH	125506B	6.50 (165)
6ML	125506B	6.50 (165)
6MM	125506B	6.50 (165)
6MH	125506B	6.50 (165)
6D	125506B	6.50 (165)

Leg Kit includes:
<ul style="list-style-type: none"> • 3 Legs (painted) • attachment hardware

Model	Seal Kit	O-Ring Kit	Hardware Kit	Volute Kit	Slicer Blade Attachment Kit	Cord Attachment Kit	Lifting Handle Kit	Leg Kit	Slicer Blade Kit	Shim Kit	Striker Plate Kit	Striker Shell Kit	Striker Hardware Kit
7366-335-1P-32N			138615-D	143127SK-D-KIT	138614D	140152-18	133032-D-KIT	125506	137223TG-ASSY-KIT	142157D-KIT	142125D-ASSY-KIT	143127SK-D-ASSY-KIT	142633-4D-KIT
7366-335-71-32N			138615-D	143127SK-D-KIT	138614D	140152-18	133032-D-KIT	125506	137223TG-ASSY-KIT	142157D-KIT	142125D-ASSY-KIT	143127SK-D-ASSY-KIT	142633-4D-KIT
7366-335-1R-32N	*138581-DX-SD		138615-D	143127SK-D-KIT	138614D	140152-18	133032-D-KIT	125506	137223TB-ASSY-KIT	142157D-KIT	142125D-ASSY-KIT	143127SK-D-ASSY-KIT	142633-4D-KIT
7366-335-72-32N	138581-DX-CC	138680-XP	138615-D	143127SK-D-KIT	138614D	140152-18	133032-D-KIT	125506	137223TB-ASSY-KIT	142157D-KIT	142125D-ASSY-KIT	143127SK-D-ASSY-KIT	142633-4D-KIT
7366-335-1S-32N	138581-DX-TC		138615-D	143127SK-D-KIT	138614D	140152-18	133032-D-KIT	125506	137223-ASY-KIT	142157D-KIT	142125D-ASSY-KIT	143127SK-D-ASSY-KIT	142633-4D-KIT
7366-335-87-32N			138615-D	143127SK-D-KIT	138614D	140152-18	133032-D-KIT	125506	137223-ASY-KIT	142157D-KIT	142125D-ASSY-KIT	143127SK-D-ASSY-KIT	142633-4D-KIT

* **NOTE:** Standard part number. For more information see page 25.

Model	Seal Kit	O-Ring Kit	Hardware Kit	Volute Kit	Slicer Blade Attachment Kit	Cord Attachment Kit	Lifting Handle Kit	Leg Kit	Slicer Blade Kit	Shim Kit	Striker Plate Kit	Striker Shell Kit	Striker Hardware Kit
7366-424-1P-32N			138615-D	133033SK-D-KIT	138614D	140152-18	133032-D-KIT	125506	133044TJ-ASSY-KIT	142157D-KIT	142137D-ASSY-KIT	133033SK-D-ASSY-KIT	142633-4D-KIT
7366-424-71-32N			138615-D	133033SK-D-KIT	138614D	140152-18	133032-D-KIT	125506	133044TJ-ASSY-KIT	142157D-KIT	142137D-ASSY-KIT	133033SK-D-ASSY-KIT	142633-4D-KIT
7366-424-1R-32N	*138581-DX-SD		138615-D	133033SK-D-KIT	138614D	140152-18	133032-D-KIT	125506	133044TB-ASSY-KIT	142157D-KIT	142137D-ASSY-KIT	133033SK-D-ASSY-KIT	142633-4D-KIT
7366-424-72-32N	138581-DX-CC 138581-DX-TC	138580-XP	138615-D	133033SK-D-KIT	138614D	140152-18	133032-D-KIT	125506	133044TB-ASSY-KIT	142157D-KIT	142137D-ASSY-KIT	133033SK-D-ASSY-KIT	142633-4D-KIT
7366-424-1S-32N			138615-D	133033SK-D-KIT	138614D	140152-18	133032-D-KIT	125506	133044-ASY-KIT	142157D-KIT	142137D-ASSY-KIT	133033SK-D-ASSY-KIT	142633-4D-KIT
7366-424-87-32N			138615-D	133033SK-D-KIT	138614D	140152-18	133032-D-KIT	125506	133044-ASY-KIT	142157D-KIT	142137D-ASSY-KIT	133033SK-D-ASSY-KIT	142633-4D-KIT
7366-410-1R-32N			138615-D	129994S4K-4D-KIT	138614D	140152-18	133032-D-KIT	125506	127263TK-ASSY-KIT	142157D-KIT	142125D-ASSY-KIT	129994SK-4D-ASSY-KIT	142633-4D-KIT
7366-410-72-32N			138615-D	129994S4K-4D-KIT	138614D	140152-18	133032-D-KIT	125506	127263TK-ASSY-KIT	142157D-KIT	142125D-ASSY-KIT	129994SK-4D-ASSY-KIT	142633-4D-KIT
7366-410-1S-32N	*138581-DX-SD		138615-D	129994S4K-4D-KIT	138614D	140152-18	133032-D-KIT	125506	127263TE-ASSY-KIT	142157D-KIT	142125D-ASSY-KIT	129994SK-4D-ASSY-KIT	142633-4D-KIT
7366-410-87-32N	138581-DX-CC 138581-DX-TC	138580-XP	138615-D	129994S4K-4D-KIT	138614D	140152-18	133032-D-KIT	125506	127263TE-ASSY-KIT	142157D-KIT	142125D-ASSY-KIT	129994SK-4D-ASSY-KIT	142633-4D-KIT
7366-410-1T-32N			138615-D	129994S4K-4D-KIT	138614D	140152-18	133032-D-KIT	125506	127263TB-ASSY-KIT	142157D-KIT	142125D-ASSY-KIT	129994SK-4D-ASSY-KIT	142633-4D-KIT
7366-410-88-32N			138615-D	129994S4K-4D-KIT	138614D	140152-18	133032-D-KIT	125506	127263TB-ASSY-KIT	142157D-KIT	142125D-ASSY-KIT	129994SK-4D-ASSY-KIT	142633-4D-KIT

* NOTE: Standard part number. For more information see page 25.

Model	Seal Kit	O-Ring Kit	Hardware Kit	Volute Kit	Slicer Blade Attachment Kit	Cord Attachment Kit	Lifting Handle Kit	Leg Kit	Slicer Blade Kit	Shim Kit	Striker Plate Kit	Striker Shell Kit	Striker Hardware Kit
7366-425-1P-32N			138615-D	133033SK-D-KIT	138614D	140152-18	133032-D-KIT	125506	133052TF-ASSY-KIT	142157D-KIT	142137D-ASSY-KIT	133033SK-D-ASSY-KIT	142633-4D-KIT
7366-425-71-32N			138615-D	133033SK-D-KIT	138614D	140152-18	133032-D-KIT	125506	133052TF-ASSY-KIT	142157D-KIT	142137D-ASSY-KIT	133033SK-D-ASSY-KIT	142633-4D-KIT
7366-425-1R-32N	*138581-DX-SD	138580-XP	138615-D	133033SK-D-KIT	138614D	140152-18	133032-D-KIT	125506	133052TB-ASSY-KIT	142157D-KIT	142137D-ASSY-KIT	133033SK-D-ASSY-KIT	142633-4D-KIT
7366-425-72-32N	138581-DX-CC		138615-D	133033SK-D-KIT	138614D	140152-18	133032-D-KIT	125506	133052TB-ASSY-KIT	142157D-KIT	142137D-ASSY-KIT	133033SK-D-ASSY-KIT	142633-4D-KIT
7366-425-1S-32N	138581-DX-TC		138615-D	133033SK-D-KIT	138614D	140152-18	133032-D-KIT	125506	133052-ASY-KIT	142157D-KIT	142137D-ASSY-KIT	133033SK-D-ASSY-KIT	142633-4D-KIT
7366-425-87-32N			138615-D	133033SK-D-KIT	138614D	140152-18	133032-D-KIT	125506	133052-ASY-KIT	142157D-KIT	142137D-ASSY-KIT	133033SK-D-ASSY-KIT	142633-4D-KIT
7366-413-1R-32N			138615-D	129994S5K-5D-KIT	138614D	140152-18	133032-D-KIT	125506	127263TP-ASSY-KIT	141579D-KIT	141601D-ASSY-KIT	129994SK-5D-ASSY-KIT	142633-5D-KIT
7366-413-72-32N			138615-D	129994S5K-5D-KIT	138614D	140152-18	133032-D-KIT	125506	127263TP-ASSY-KIT	141579D-KIT	141601D-ASSY-KIT	129994SK-5D-ASSY-KIT	142633-5D-KIT
7366-413-1S-32N	*138581-DX-SD	138580-XP	138615-D	129994S5K-5D-KIT	138614D	140152-18	133032-D-KIT	125506	127263TK-ASSY-KIT	141579D-KIT	141601D-ASSY-KIT	129994SK-5D-ASSY-KIT	142633-5D-KIT
7366-413-87-32N	138581-DX-CC		138615-D	129994S5K-5D-KIT	138614D	140152-18	133032-D-KIT	125506	127263TK-ASSY-KIT	141579D-KIT	141601D-ASSY-KIT	129994SK-5D-ASSY-KIT	142633-5D-KIT
7366-413-1T-32N	138581-DX-TC		138615-D	129994S5K-5D-KIT	138614D	140152-18	133032-D-KIT	125506	127263TF-ASSY-KIT	141579D-KIT	141601D-ASSY-KIT	129994SK-5D-ASSY-KIT	142633-5D-KIT
7366-413-88-32N			138615-D	129994S5K-5D-KIT	138614D	140152-18	133032-D-KIT	125506	127263TF-ASSY-KIT	141579D-KIT	141601D-ASSY-KIT	129994SK-5D-ASSY-KIT	142633-5D-KIT

* NOTE: Standard part number. For more information see page 25.

BARNES®



burks®

WEINMAN®

DEMING®

PROSSER®

Limited 24 Month Warranty

Crane Pumps & Systems warrants that products of our manufacture will be free of defects in material and workmanship under normal use and service for twenty-four (24) months after manufacture date, when installed and maintained in accordance with our instructions. This warranty gives you specific legal rights, and there may also be other rights which vary from state to state. In the event the product is covered by the Federal Consumer Product Warranties Law (1) the duration of any implied warranties associated with the product by virtue of said law is limited to the same duration as stated herein, (2) this warranty is a LIMITED WARRANTY, and (3) no claims of any nature whatsoever shall be made against us, until the ultimate consumer, his successor, or assigns, notifies us in writing of the defect, and delivers the product and/or defective part(s) freight prepaid to our factory or nearest authorized service station. Some states do not allow limitations on how long an implied warranty lasts, so the above limitation may not apply. **THE SOLE AND EXCLUSIVE REMEDY FOR BREACH OF ANY AND ALL WARRANTIES WITH RESPECT TO ANY PRODUCT SHALL BE TO REPLACE OR REPAIR AT OUR ELECTION, F.O.B. POINT OF MANUFACTURE OR AUTHORIZED REPAIR STATION, SUCH PRODUCTS AND/OR PARTS AS PROVEN DEFECTIVE. THERE SHALL BE NO FURTHER LIABILITY, WHETHER BASED ON WARRANTY, NEGLIGENCE OR OTHERWISE.** Unless expressly stated otherwise, guarantees in the nature of performance specifications furnished in addition to the foregoing material and workmanship warranties on a product manufactured by us, if any, are subject to laboratory tests corrected for field performance. Any additional guarantees, in the nature of performance specifications must be in writing and such writing must be signed by our authorized representative. Due to inaccuracies in field testing if a conflict arises between the results of field testing conducted by or for user, and laboratory tests corrected for field performance, the latter shall control. **RECOMMENDATIONS FOR SPECIAL APPLICATIONS OR THOSE RESULTING FROM SYSTEMS ANALYSES AND EVALUATIONS WE CONDUCT WILL BE BASED ON OUR BEST AVAILABLE EXPERIENCE AND PUBLISHED INDUSTRY INFORMATION. SUCH RECOMMENDATIONS DO NOT CONSTITUTE A WARRANTY OF SATISFACTORY PERFORMANCE AND NO SUCH WARRANTY IS GIVEN.**

This warranty shall not apply when damage is caused by (a) improper installation, (b) improper voltage (c) lightning (d) excessive sand or other abrasive material (e) scale or corrosion build-up due to excessive chemical content. Any modification of the original equipment will also void the warranty. We will not be responsible for loss, damage or labor cost due to interruption of service caused by defective parts. Neither will we accept charges incurred by others without our prior written approval.

This warranty is void if our inspection reveals the product was used in a manner inconsistent with normal industry practice and/or our specific recommendations. The purchaser is responsible for communication of all necessary information regarding the application and use of the product. **UNDER NO CIRCUMSTANCES WILL WE BE RESPONSIBLE FOR ANY OTHER DIRECT OR CONSEQUENTIAL DAMAGES, INCLUDING BUT NOT LIMITED TO TRAVEL EXPENSES, RENTED EQUIPMENT, OUTSIDE CONTRACTOR FEES, UNAUTHORIZED REPAIR SHOP EXPENSES, LOST PROFITS, LOST INCOME, LABOR CHARGES, DELAYS IN PRODUCTION, IDLE PRODUCTION, WHICH DAMAGES ARE CAUSED BY ANY DEFECTS IN MATERIAL AND/OR WORKMANSHIP AND/OR DAMAGE OR DELAYS IN SHIPMENT. THIS WARRANTY IS EXPRESSLY IN LIEU OF ANY OTHER EXPRESS OR IMPLIED WARRANTY, INCLUDING ANY WARRANTY OF MERCHANTABILITY OR FITNESS FOR A PARTICULAR PURPOSE.**

No rights extended under this warranty shall be assigned to any other person, whether by operation of law or otherwise, without our prior written approval.



PUMPS & SYSTEMS

A Crane Co. Company

420 Third Street
Piqua, Ohio 45356
(937) 778-8947
Fax (937) 773-7157
www.cranepumps.com

83 West Drive
Brampton, Ont. Canada L6T 2J6
(905) 457-6223
Fax (905) 457-2650

**IMPORTANT!
WARRANTY INFORMATION**

Warranty will be voided if the product
is serviced by any
Unauthorized Service Center.

**IMPORTANT!
WARRANTY REGISTRATION**

Your product is covered by the enclosed Warranty.
To complete the Warranty Registration Form go to:

<http://www.cranepumps.com/ProductRegistration/>

If you have a claim under the provision of the warranty, contact your local
Crane Pumps & Systems, Inc. Distributor.

RETURNED GOODS

**RETURN OF MERCHANDISE REQUIRES A "RETURNED GOODS AUTHORIZATION".
CONTACT YOUR LOCAL CRANE PUMPS & SYSTEMS, INC. DISTRIBUTOR.**



**Products Returned Must Be Cleaned, Sanitized,
Or Decontaminated As Necessary Prior To Shipment,
To Insure That Employees Will Not Be Exposed To Health
Hazards In Handling Said Material. All Applicable Laws
And Regulations Shall Apply.**



START-UP REPORT

General Information

Pump Owner's Name: _____
Address: _____
Location of Installation: _____
Contact Person: _____ Phone: _____
Purchased From: _____

Nameplate Data

Pump Model #: _____ Serial #: _____
Part #: _____ Impeller Diameter: _____
Voltage: _____ Phase: _____ \emptyset Hertz: _____ Horsepower: _____
Full Load Amps: _____ Service Factor Amps: _____
Motor Manufacturer: _____

Controls

Control panel manufacturer: _____
Model/Part number: _____
Number of pumps operated by control panel: _____
Short circuit protection? YES___ NO___ Type: _____
Number and size of short circuit device(s): _____ Amp rating: _____
Overload Type: _____ Size: _____ Amp rating: _____
Do protection devices comply with pump and motor Amp rating? YES___ NO___
Are all electrical and panel entry connections tight? YES___ NO___
Is the interior of the panel dry? YES___ NO___
Liquid level Control Brand and Model: _____

Pre-Startup

All Pumps

Type of equipment: NEW___ REBUILT___ USED___
Condition of equipment at Start-Up: DRY___ WET___ MUDDY___
Was Equipment Stored? YES___ NO___ Length of Storage: _____
Liquid being pumped: _____ Liquid Temperature: _____
Supply Voltage/Phase/Frequency matches nameplate? YES___ NO___
Shaft turns freely? YES___ NO___
Direction of rotation verified for 3 \emptyset motors? YES___ NO___
Debris in piping or wet well? YES___ NO___
Debris removed in your presence? YES___ NO___
Pump case/wet well filled with liquid before startup? YES___ NO___
Is piping properly supported? YES___ NO___

Non-Submersible Pumps

Is base plate properly installed / grouted? YES___ NO___ N/A___
Coupling Alignment Verified per I&O Manual? YES___ NO___ N/A___
Grease Cup/Oil Reservoir Level checked? YES___ NO___ N/A___

Submersible Pumps

Resistance of cable and pump motor (measured at pump control):

Red-Black: _____ Ohms(Ω) Red-White: _____ Ohms(Ω) White-Black: _____ Ohms(Ω)

Resistance of Ground Circuit between Control Panel and outside of pump: _____ Ohms(Ω)

MEG Ohms check of insulation:

Red to Ground: _____ White to Ground: _____ Black to Ground: _____

Operational Checks

Is there noise or vibration present? YES___ NO___ Source of noise/vibration: _____

Does check valve operate properly? YES___ NO___ N/A___

Is system free of leaks? YES___ NO___ Leaks at: _____

Does system appear to operate at design flow rate? YES___ NO___

Nominal Voltage: _____ Phase: 1Ø 3Ø (select one)

Voltage Reading at panel connection, Pump OFF: L1, L2 _____ L2, L3 _____ L1, L3 _____

Voltage Reading at panel connection, Pump ON: L1, L2 _____ L2, L3 _____ L1, L3 _____

Amperage Draw, Pump ON: L1 _____ L2 _____ L3 _____

Submersible Pumps

Are BAF and guide rails level / plumb? YES___ NO___

Is pump seated on discharge properly? YES___ NO___

Are level controls installed away from turbulence? YES___ NO___

Is level control operating properly? YES___ NO___

Is pump fully submerged during operation? YES___ NO___

Follow up/Corrective Action Required

YES___ NO___

Additional Comments:

Startup performed by: _____ Date: _____

Present at Start-Up

() Engineer: _____ () Operator: _____

() Contactor: _____ () Other: _____

All parties should retain a copy of this report for future trouble shooting/reference



PUMPS & SYSTEMS

A Crane Co. Company

420 Third Street
Piqua, Ohio 45356
(937) 778-8947
Fax (937) 773-7157
www.cranepumps.com

83 West Drive
Brampton, Ont. Canada L6T 2J6
(905) 457-6223
Fax (905) 457-2650