

Demersible Non-Clog Pumps

#4 Frame Driver

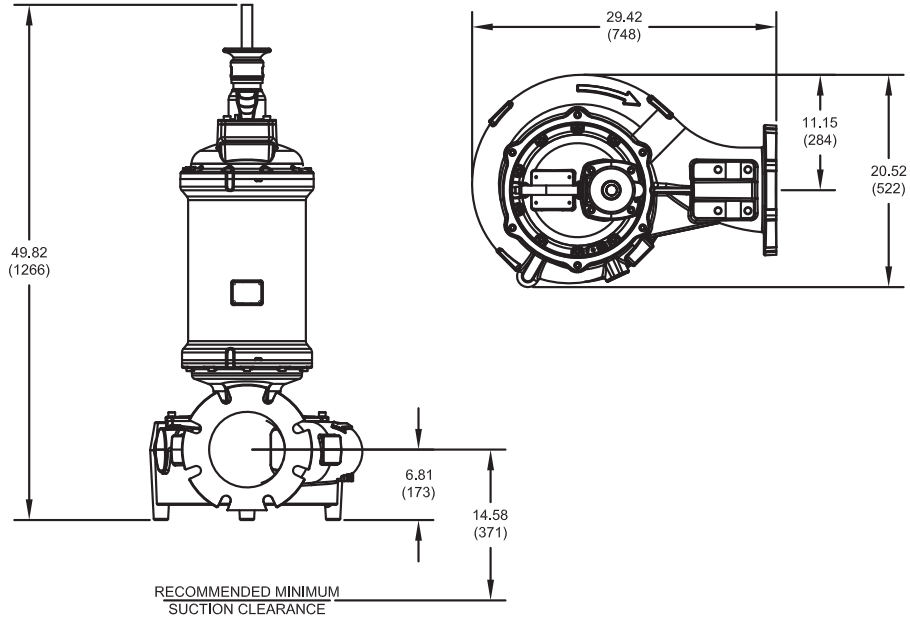

inches
(mm)

Model No.	Imp. Dia. inches (mm)	HP	Volt	PH	Hz	RPM	NEMA Start Code	Full Load Amps	S.F.	S.F. Amps	Locked Rotor Amps	Cord P/N ▲	Cord Size
7365*-867-65-30N	10.63 (270)	50.0	460	3	60	1750	G	77.8	1.2	93.4	359.0	138319	2/4 - 18/4
								71.4		82.3			
7365*-867-80-30N	10.63 (270)	50.0	575	3	60	1750	G	33.2	1.2	38.9	191.9	125499	8/4 - 18/4
7365*-867-66-30N	11.02 (280)	60.0	460	3	60	1750	G	26.6	1.2	31.1	153.5	125497	12/4 - 18/4
7365*-867-81-30N	11.02 (280)	60.0	575	3	60	1750	E	93.4	1.2	116.9	359.0	138319	2/4 - 18/4
								82.3		98.7			

IMPORTANT !

Moisture and Temperature sensor leads are integral to power cord.

Pump rated for operation at ± 10% voltage at motor.

▲ Cord Suffix: XC - 30 Feet, XF - 50 Feet, XJ - 75 Feet, or XL - 100 Feet.

▲ Cord sold separately.

Size 8DA (Vortex)

3.50" Spherical Solids Handling
7365*-867

DEMING®

www.cranepumps.com

Demersible Non-Clog Pumps

#5 Frame Driver

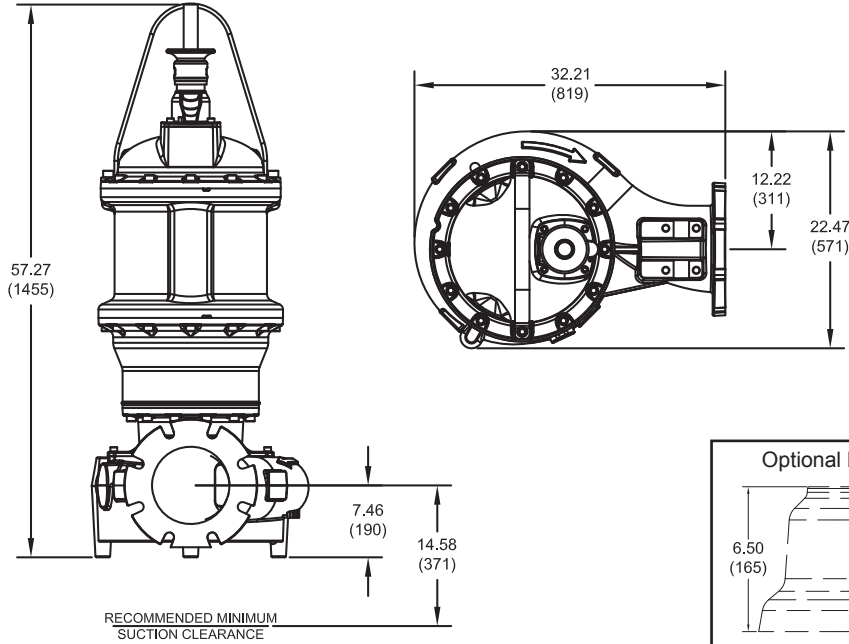

Model No.	Imp. Dia. inches (mm)	HP	Volt	PH	Hz	RPM	NEMA Start Code	Full Load Amps	S.F.	S.F. Amps	Locked Rotor Amps	Cord P/N ▲	Cord Size
7365*-867-67-30N	11.61 (295)	75.0	460	3	60	1750	F	38.9	1.2	45.9	191.9	125499	8/4 - 18/4
7365*-867-82-30N	11.61 (295)	75.0	575	3	60	1750	F	31.1	1.2	36.7	153.5	125499	8/4 - 18/4
7365*-867-68-30N	12.00 (305)	100.0	460	3	60	1750	E	106.0	1.2	126.4	486.0	138319	2/4 - 18/4
7365*-867-83-30N	12.00 (305)	100.0	575	3	60	1750	E	53.0	1.2	63.2	243.0	138318	6/4 - 18/4
7365*-867-69-30N	12.60 (320)	125.0	460	3	60	1750	E	42.4	1.2	50.6	194.4	138317	8/4 - 18/4
7365*-867-84-30N	12.60 (320)	125.0	575	3	60	1750	F	67.1	1.2	79.0	339.0	138318	6/4 - 18/4
7365*-867-97-30N	13.78 (350)	150.0	460	3	60	1750	F	53.7	1.2	63.2	271.2	138318	6/4 - 18/4
7365*-867-1G-30N	13.78 (350)	150.0	575	3	60	1750	E	79.0	1.2	95.5	339.0	138319	2/4 - 18/4

IMPORTANT !

Moisture and Temperature sensor leads are integral to power cord.

Pump rated for operation at ± 10% voltage at motor.

▲ Cord Suffix: XC - 30 Feet, XF - 50 Feet, XJ - 75 Feet, or XL - 100 Feet.

▲ Cord sold separately.

SECTION 42A
PAGE 88
DATE

CRANE
A Crane Co. Company

PUMPS & SYSTEMS

USA: (937) 778-8947 • Canada: (905) 457-6223 • International: (937) 615-3598