

**Note:** If the pump is dismantled during the warranty period, the pump is no longer under warranty.

### Dismantling:

1. Tools required for dismantling the PAH 25 - 32 pump.



2. Remove the parallel key and unscrew the front screw.



3. Unscrew the screws in the front flange.



4. Remove the front flange.



5. Remove the shaft seal using two screwdrivers.



6. Remove the guide pin from the housing and the two guide pins from the swash plate.





7. Remove the swash plate using the front screw.



8. Remove the cylinder barrel from the housing.



9. Unscrew the six screws in the end cover.

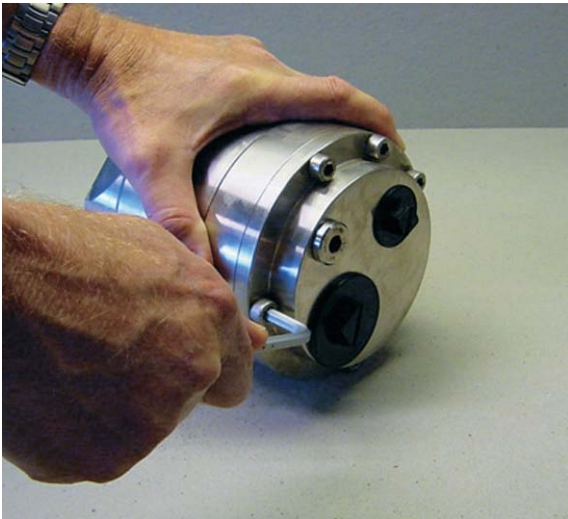

10. Separate the housing and the end cover.



11. Remove the valve plate from the end cover.



12. Remove the guide pins and the guide.

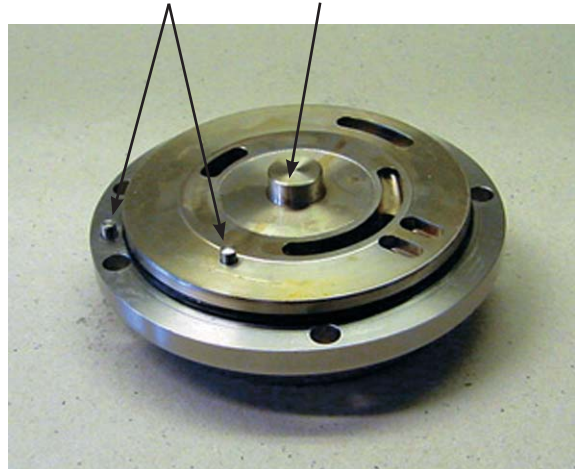



13. Remove the pistons.



14. Remove the retaining plate.



15. Remove the retaining ball.



16. Remove the the thrust plate using two screwdrivers.

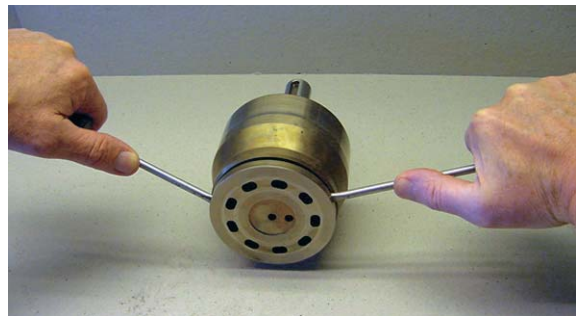

17. Remove the ceramic ring from the front flange.



18. The ceramic ring removed from the front flange.



19. Wash all parts and replace all seals (inclusive shaft seal).

20. Inspect all parts carefully (see "Inspection") and replace any worn parts.

21. If the pump has failed, the reason for the failure must be found and fixed before the repaired pump is re-installed.

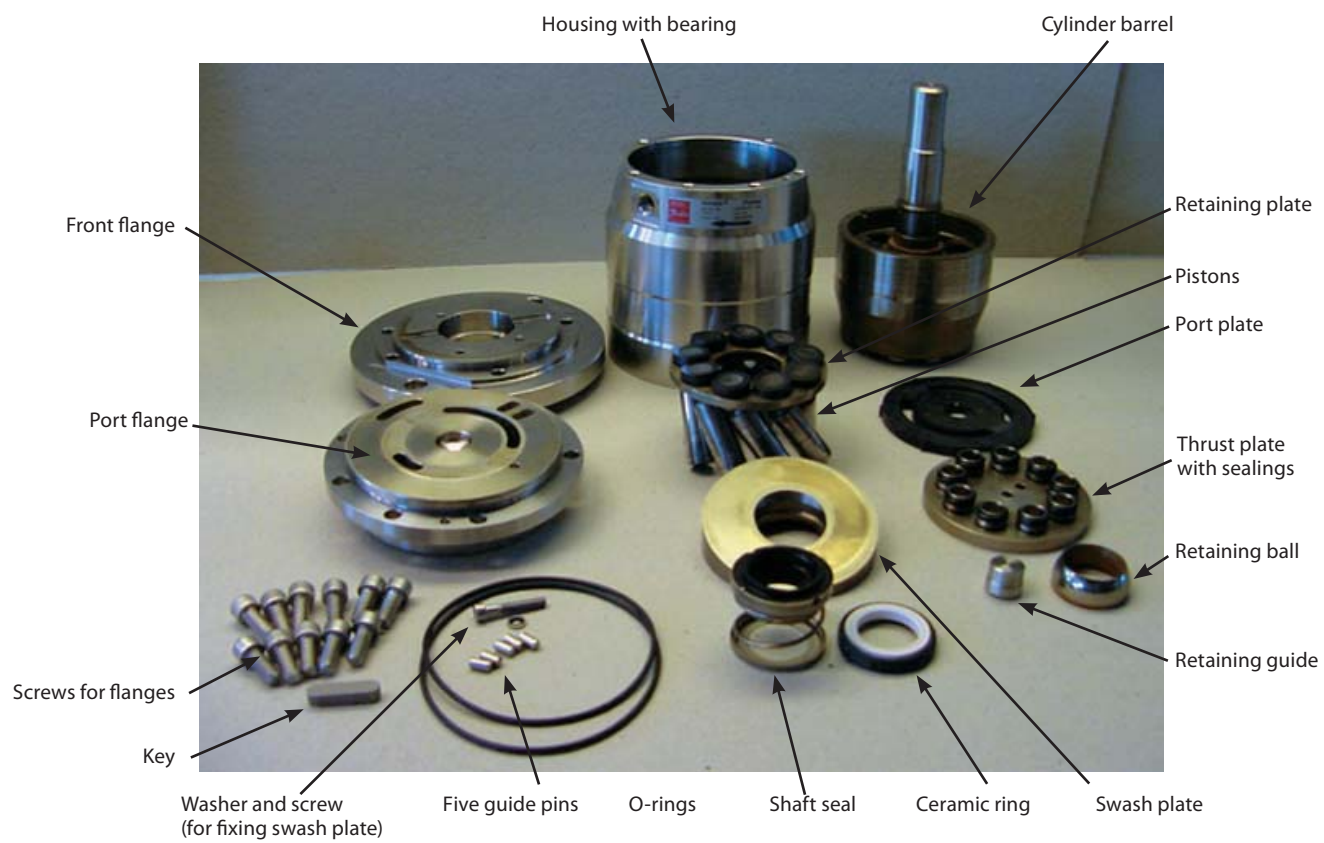

## Inspection:

### Port plate and thrust plate

1. Neither port plate nor thrust plate must show any sign of wear.

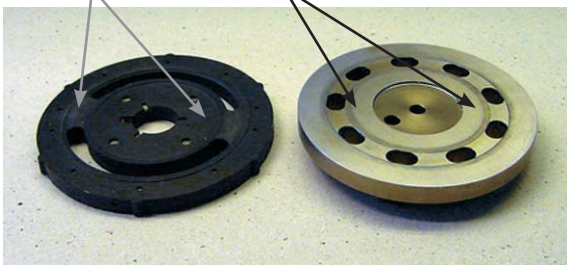

2. Hold a ruler against the surface of the plate and check the tightness against a light source.



3. Check that both O-rings and back-up rings are not broken and do not show severe wear.

### Pistons

1. The play in the ball and socket joint must not exceed 0.1 mm.
2. The thickness of the piston shoes must be at least 4.1 mm.

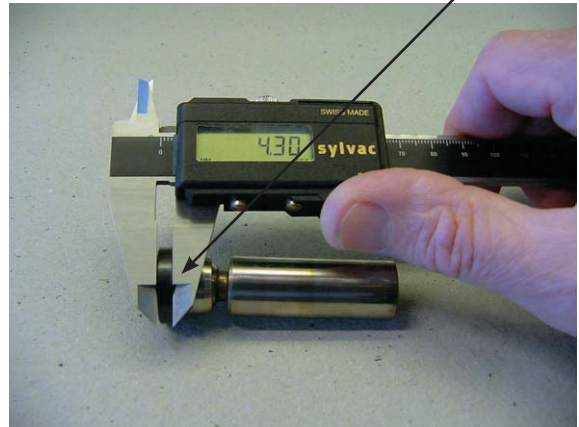

3. Hold a ruler against the surfaces of the piston shoes to check that the surfaces are even and smooth and without any scratches.

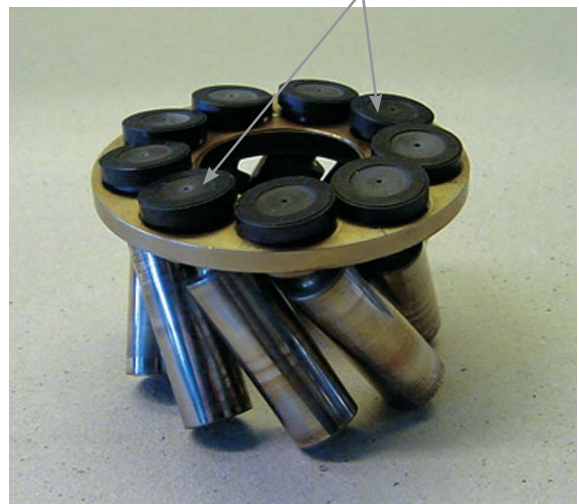

4. Pumps for technical water only:

It is acceptable that the (black) treated surfaces of the pistons are partly worn.



*Cylinder barrel:*

1. Check the outer bearing surface for large wear grooves (not critical).
2. Check that the bushings are free from seizure and large scratches.



3. Ensure that the pistons can move freely in the bushings.

*Housing:*

1. Check the bearing (black) for large wear grooves (not critical).

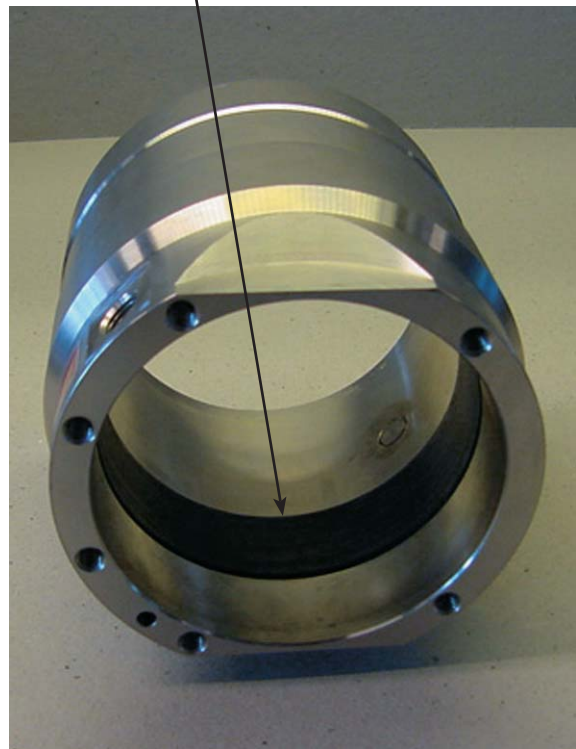

*Swash plate:*

1. Check that the surface of the swash plate is smooth and without any large scratches (depth more than 0.1 mm).



## Assembly:

1. Parts and tools required for assembly.



2. Check that all parts are OK. Replace all seals.
3. Mount the O-ring, the guide and the guide pins on the port flange.

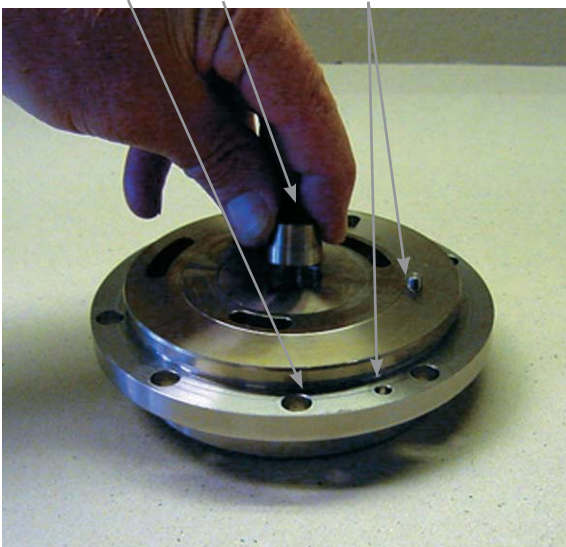

4. Mount the valve plate in its right position using the pin as guide.



5. Mount the housing using the pin as guide.



6. Mount the thrust plate with sealings on the cylinder barrel.



7. Press the thrust plate into the cylinder barrel using a table or the like as support.





8. Mount the cylinder barrel in the housing.



10. Mount the retaining plate (smallest centre diameter pointing upwards).

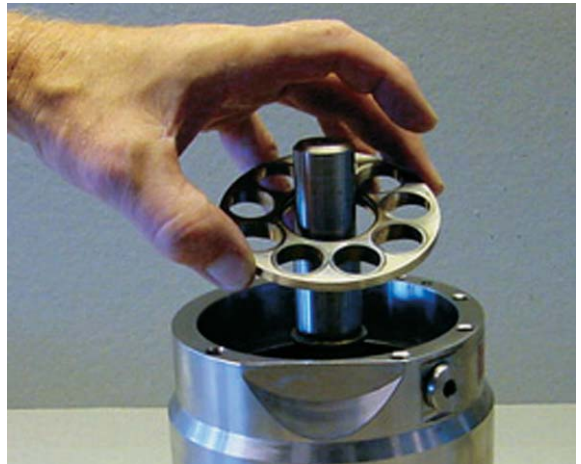

9. Slide the retaining ball (smallest diameter pointing upwards) down the shaft.



11. Mount the pistons.



12. Mount the ceramic ring on the tool.

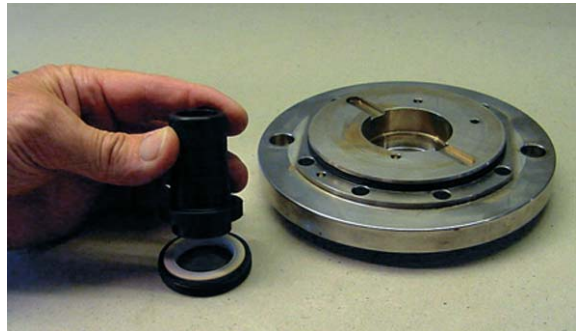

13. Mount the ceramic ring by pressing the tool as far down in the front flange as possible.





14. Push the tool through the front flange.



17. Press the swash plate against the flange and screw the tools together.



15. Mount the shaft seal (carbon surface pointing downwards), the spring, and the washer (edge pointing downwards) by sliding them over the tool.

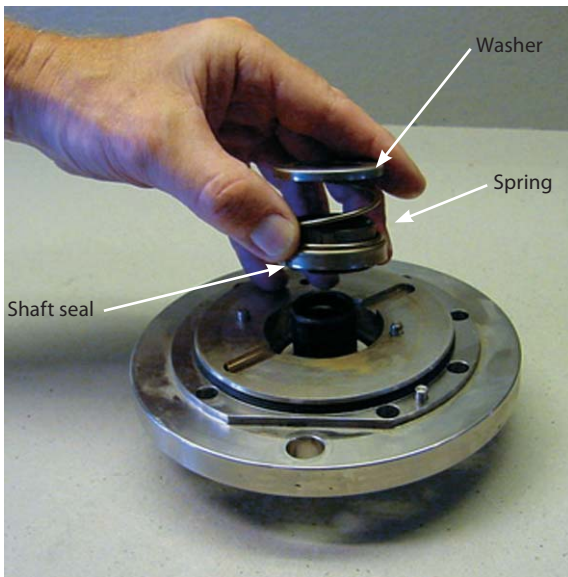

18. Mount the O-ring on the front flange.

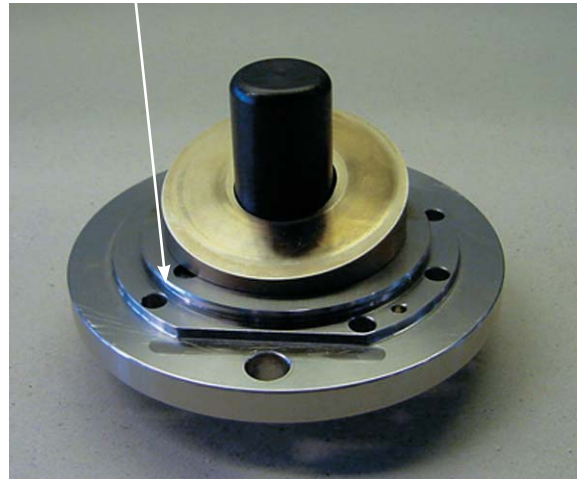

16. Mount the swash plate on the front flange using the pins as guide.

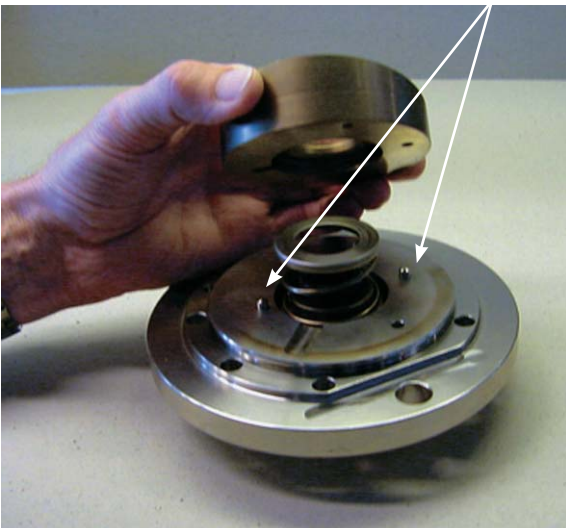

19. Mount the washer and the screw in the front flange to fix the swash plate.

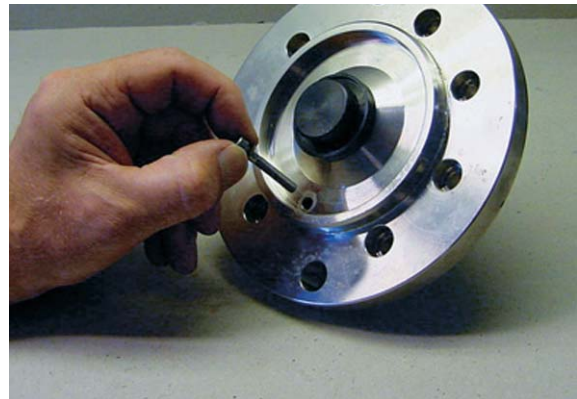

20. Tighten the screw to a torque of 5 Nm and remove the tool.





21. Mount the tool over the shaft.



25. Tighten the screws to a torque of 30 Nm and mount the parallel key on the shaft.



22. Mount the front flange on the housing using the pin as guide.



23. Remove the tool.

24. Mount the screws in the front flange.



Service kit list for PAH 25 - 32

Pos.	Qty.	Unit	Designation	Material	180B4115 - Shaft seal	180B4116 - Valve plate	180B4119 - Piston kit (standard pump)	180B4117 - Piston kit (tech. water pump)	180B4120 - Cylinder barrel; (standard pump)	180B4118 - Cylinder barrel; (tech. water pump)	180Z0236 - Shaft seal tool set
-	1	Pc.	Shaft bush, torpedo	-							X
-	1	Pc.	Press tool for 28 mm shaft	-							X
-	1	Pc.	Mounting screw	-							X
4	1	Pc.	Shaft seal	AISI304/NBR	X						
5	1	Pc.	Housing	AISI304							
6	1	Pc.	Swash plate	Stainless steel (1.4057)							
7	5	Pcs.	Pin	AISI304	X						
10	1	Pc.	Retaining plate	AISI304			X	X			
11	9	Pcs.	Piston	Stainless steel (1.4057)			X	X			
12	9	Pcs.	O-ring	NBR		X					
13	9	Pcs.	Back-up ring	PEEK		X					
14	1	Pc.	Valve plate	Stainless steel (1.4057)		X					
16	1	Pc.	Retainer guide	Stainless steel (1.4057)			X	X			
17	1	Pc.	Cylinder barrel	Stainless steel (1.4057)					X	X	
18	1	Pc.	Spring	Stainless steel (1.4068)							
19	1	Pc.	Spring guide	PEEK							
20	1	Pc.	Cir clips	Stainless steel (1.4068)							
21	1	Pc.	Port plate	AISI304/PEEK		X					
22	1	Pc.	Pin	AISI304							
24	1	Pc.	O-ring	NBR							
25	1	Pc.	Port flange	AISI304							
26	12	Pcs.	Screw	AISI304	X						
27	1	Pc.	Bleed screw	AISI304							
28	1	Pc.	Flange	AISI304							
29	2	Pcs.	Screw	AISI304							
30	1	Pc.	Key	AISI302	X						
31	1	Pc.	Plug	Polymer							
32	1	Pc.	Plug	Polymer							
33	1	Pc.	Sealing	NBR	X						
34	1	Pc.	Screw	AISI304	X						
35	1	Pc.	O-ring	NBR	X						
36	2	Pcs.	O-ring	NBR							
-	1	Pc.	Service instruction (180R9095)		X	X	X	X	X	X	



Exploded view PAH 25 -32

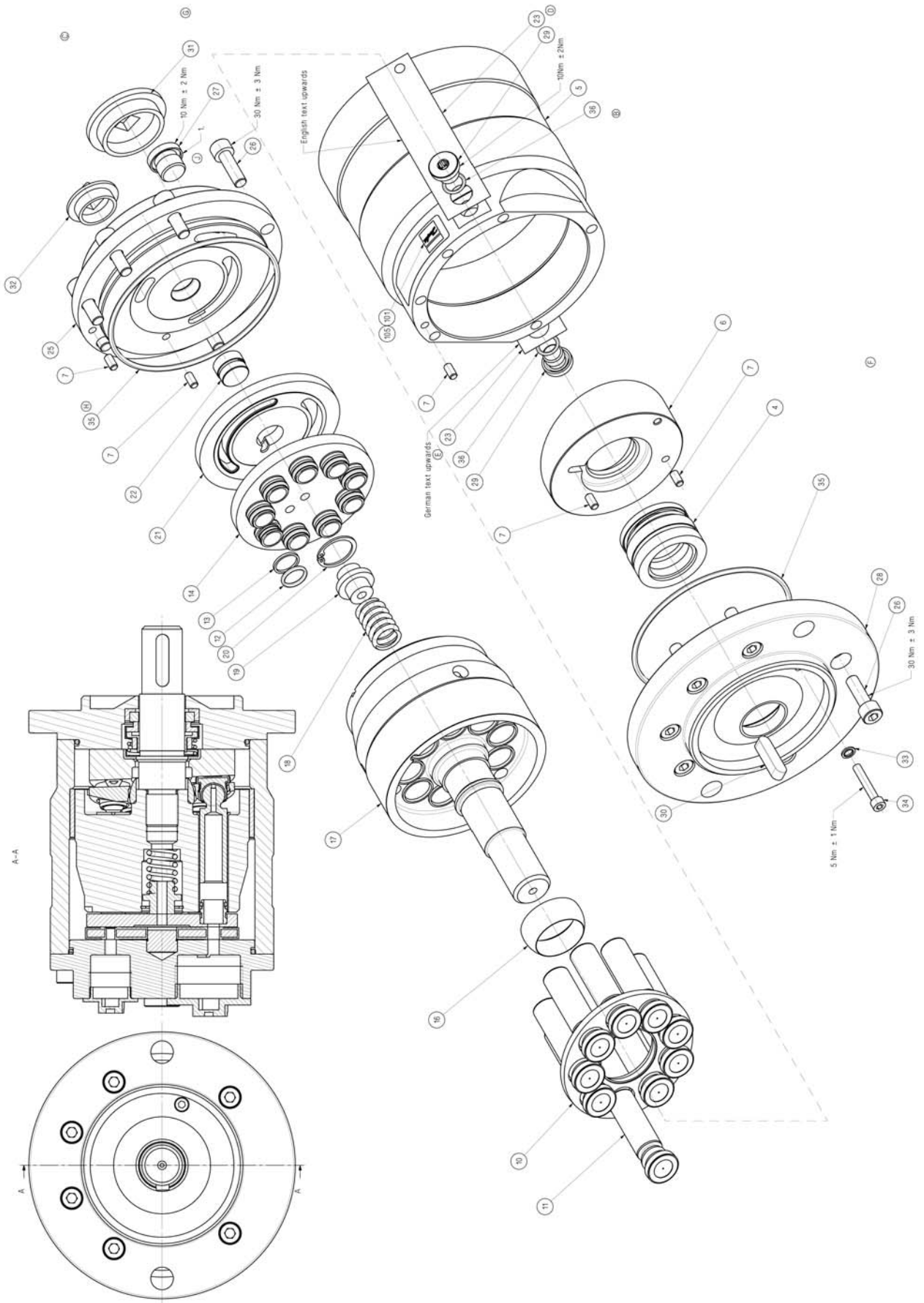







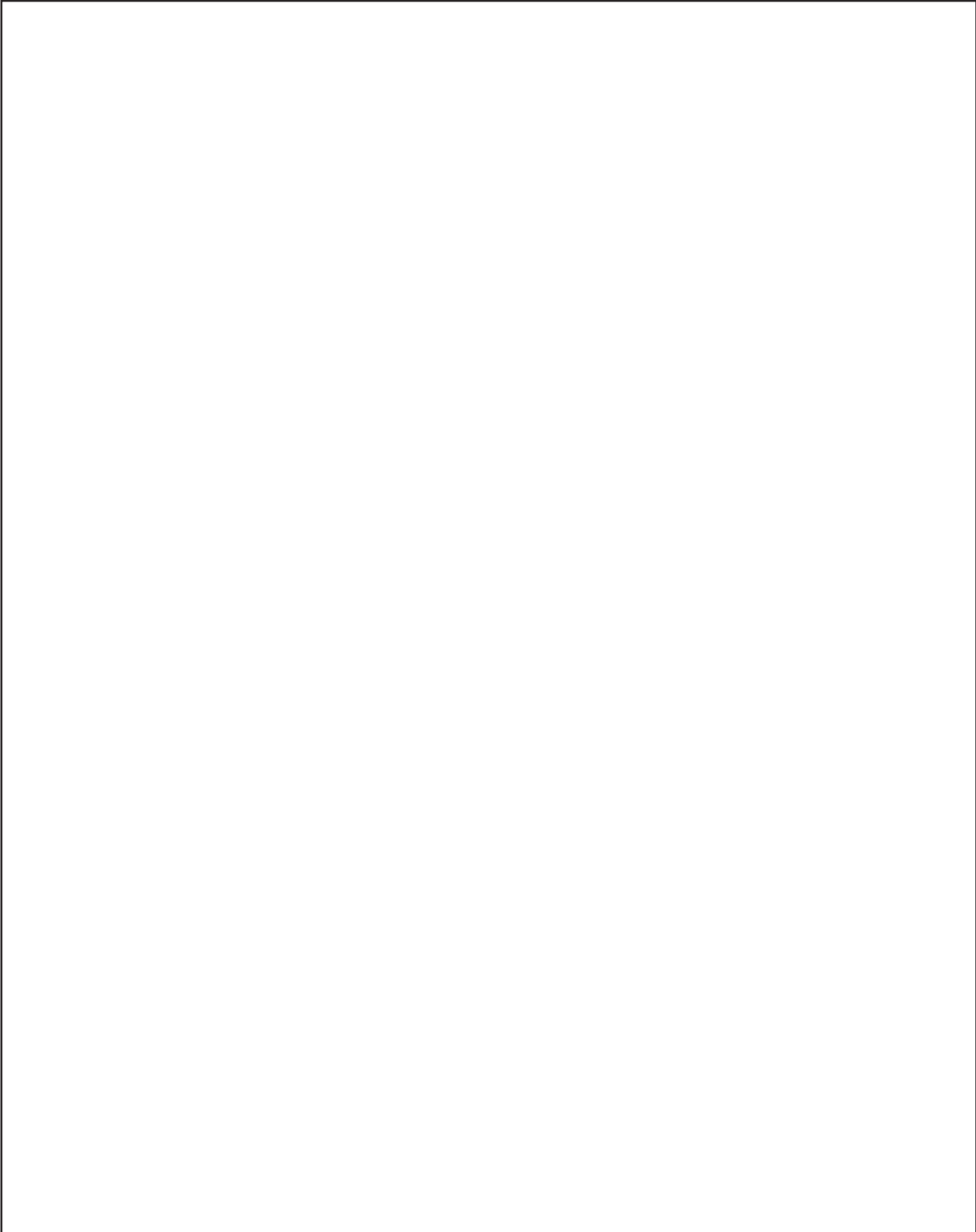

Danfoss can accept no responsibility for possible errors in catalogues, brochures and other printed material. Danfoss reserves the right to alter its products without notice. This also applies to products already on order provided that such alterations can be made without subsequential changes being necessary in specifications already agreed. All trademarks in this material are property of the respective companies. Danfoss and the Danfoss logotype are trademarks of Danfoss A/S. All rights reserved.

