



Data sheet

Data sheet APP 21-43



Table of Contents

1.	General information.....	2
2.	Benefits.....	3
3.	Technical data	3
4.	Variants.....	4
5.	Flow at different rpm.....	4
6.	Flushing valve.....	6
7.	Power requirements	6
8.	Temperature and corrosion.....	7
8.1	Operation.....	7
8.2	Storage	7
9.	Noise level	7
10.	Filtration.....	8
11.	Dimensions	8
12.	Dimensions, complete unit.....	9
13.	Installation.....	11
13.1	Mounting	11
13.2	Open-ended system with direct water supply.....	11
13.3	RO system with APP pump	12
14.	Service.....	12
14.1	Warranty.....	12
14.2	Maintenance.....	12
14.3	Repair	12

1. General information

APP 21-43 pumps are designed to supply low viscosity and corrosive fluids under high pressure, e.g. in seawater reverse osmosis filtration applications and for high pressure salt water pumping.

The pumps are based on the axial piston principle enabling a very light and compact design, and they are designed so that the

lubrication of the moving parts in the pumps is provided by the fluid itself. No oil lubrication is thus required.

The pumps are supplied with an integrated flushing valve that allows the salt water to flow from inlet to the outlet, when the pump is not running.

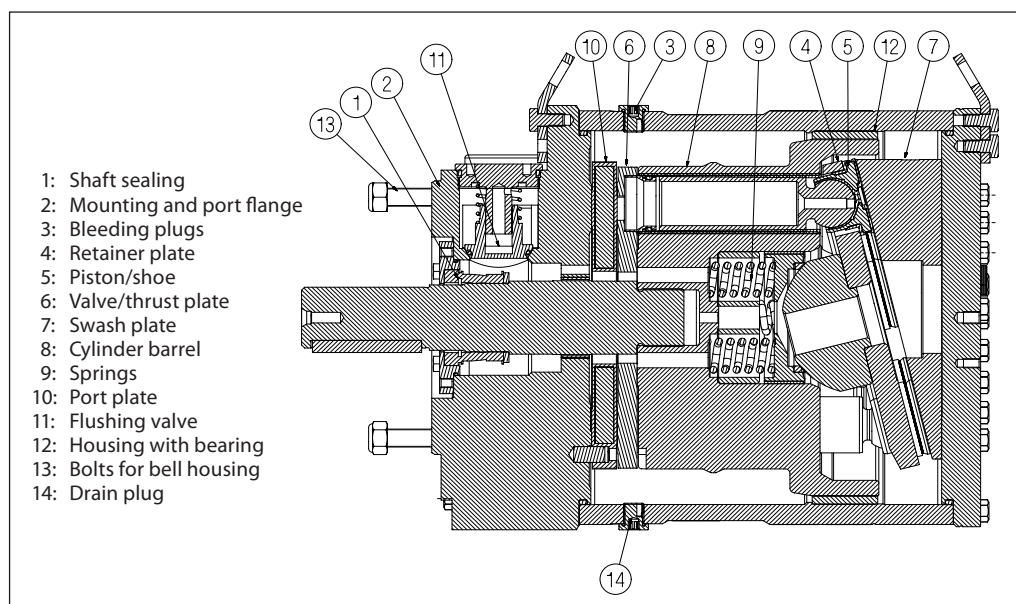

All parts included in the pumps are designed to provide long service life, i.e. long service life with a constantly high efficiency and minimum service required.

The pumps are fixed displacement pumps in which the flow is proportional to the number of revolutions of the input shaft and the pump displacement.

2. Benefits

- One of the smallest and lightest pumps on the market
- Can be powered by a combustion engine provided that a special coupling is used.
- Long service life / No preventive maintenance required in the warranty period.
- Generates insignificant pulsations in the pressure line.
- No oil lubricant required
- Integrated flushing valve
- All parts of the pump are made of non-corrosive materials, e.g. Duplex (EN1.4462/ UNS S31803-S32205) and Super Duplex (EN1.4410/UNS S32750) stainless steel and carbon reinforced PEEK
- High efficiency

3. Technical data

APP Pumps		APP 21 1200	APP 21 1500	APP 24 1200	APP 24 1500	APP 26 / 1200	APP 26 / 1500	APP 30 / 1200	APP 30 / 1500	APP 38 / 1500	APP 43 / 1700
Code number Standard		180B3051	180B3052	180B3054	180B3055	180B3056	180B3057	180B3060	180B3062	180B3071	180B3072
Geometric displacement	cm ³ /rpm	308	256	362	282	389	308	444	362	444	444
	in ³ /rpm	18.8	15.6	22.1	17.2	23.7	18.8	27.1	22.1	27.1	27.1
Rated flow at max. speed ¹⁾	m ³ /h	21.1	21.9	24.8	24.1	26.6	26.6	30.7	31.3	38.4	44.6
	gpm	92.9	96.4	109	106.2	117.1	117.4	135.1	137.7	168.9	196.4
Outlet min. pressure ²⁾	bar	30	30	30	30	30	30	30	30	30	30
	psi	435	435	435	435	435	435	435	435	435	435
Outlet max. pressure, continuous ³⁾	bar	80	80	80	80	80	80	80	80	80	70
	psi	1,160	1,160	1,160	1,160	1,160	1,160	1,160	1,160	1,160	1,015
Inlet min. pressure	bar	2	2	2	2	2	2	2	2	2	3
	psi	29	29	29	29	29	29	29	29	29	43
Inlet max. pressure, continuous	bar	5	5	5	5	5	5	5	5	5	5
	psi	72.5	72.5	72.5	72.5	72.5	72.5	72.5	72.5	72.5	72.5
Inlet max. pressure, peak	bar	10	10	10	10	10	10	10	10	10	10
	psi	145	145	145	145	145	145	145	145	145	145
Max. speed continuous	rpm	1200	1500	1200	1500	1200	1500	1200	1500	1500	1700
Min. speed continuous	rpm	700	700	700	700	700	700	700	700	700	700
Power requirement at max. speed and 80 bar (1160 psi)	kW	55	59	64	65	70	71	81	83	101	105
	hp	73.6	78.9	86.3	86.9	93.8	95.1	108.3	111.6	135.3	141.4
Torque at 80 bar	Nm	431	371	510	410	556	451	639	530	643	593 ⁴⁾
	lbf-ft	318	273.6	376	302	410	332.6	471.3	391	474.3	437.1 ⁴⁾
Weight	kg	105	105	105	105	105	105	105	105	105	105
	lb	231.5	231.5	231.5	231.5	231.5	231.5	231.5	231.5	231.5	231.5
Integrated flushing valve		Yes	Yes	Yes	Yes	Yes	Yes	Yes	Yes	Yes	Yes

¹⁾ Typical average flow at 60 bar (870 psi)

²⁾ For lower pressure, please contact Danfoss High Pressure Pumps

³⁾ For higher pressure, please contact Danfoss High Pressure Pumps

⁴⁾ Torque at 70 bar

The pump is designed according to EN809.

4. Variants

- Available as ATEX certified. Category 2, zone 1 and category 3, zone 2
- Available with pressure containing parts in Super Duplex (according to NORSOK)
- Available with material certificates on metallic wetted parts
- Available with API 674 design verification

For more details on the variants, please contact the Danfoss High Pressure Pumps.

5. Flow at different rpm

When using the diagrams shown below, it is easy to select the pump which fits the application best if the flow required and the rotation speed (rpm) of the pump are known.

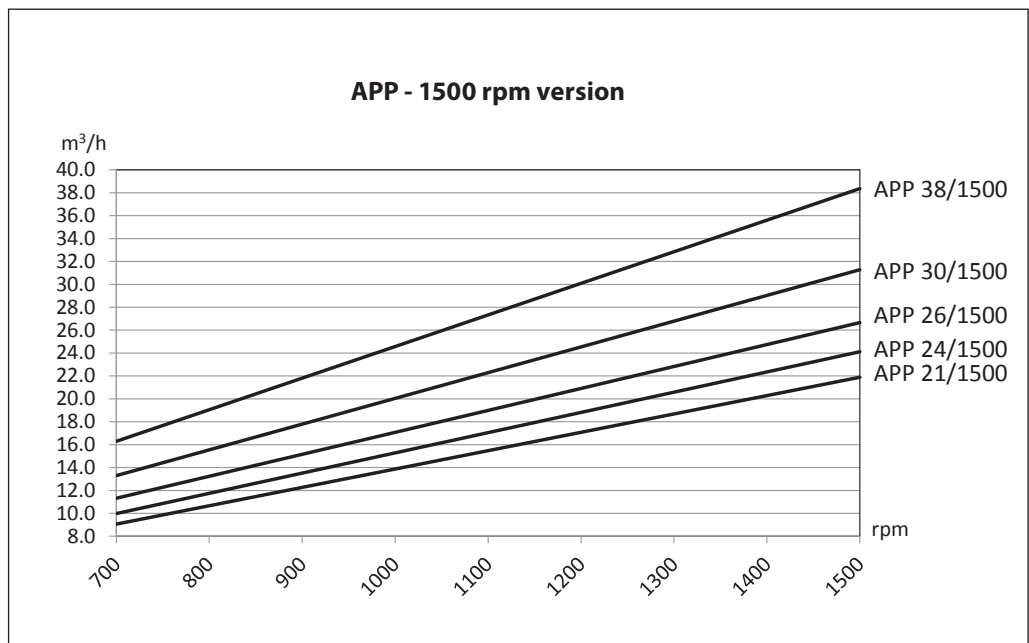
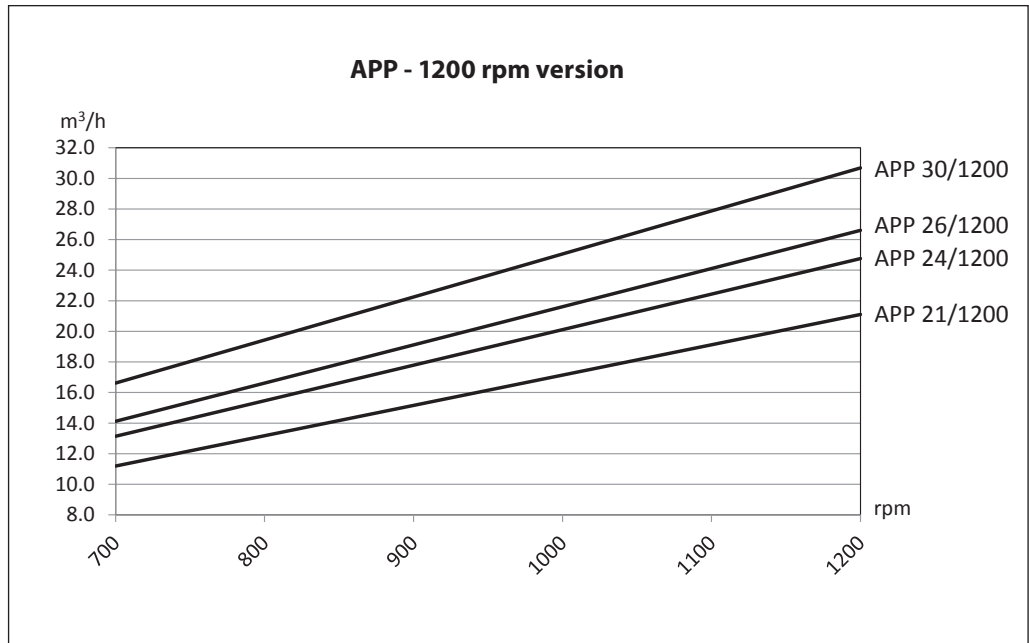

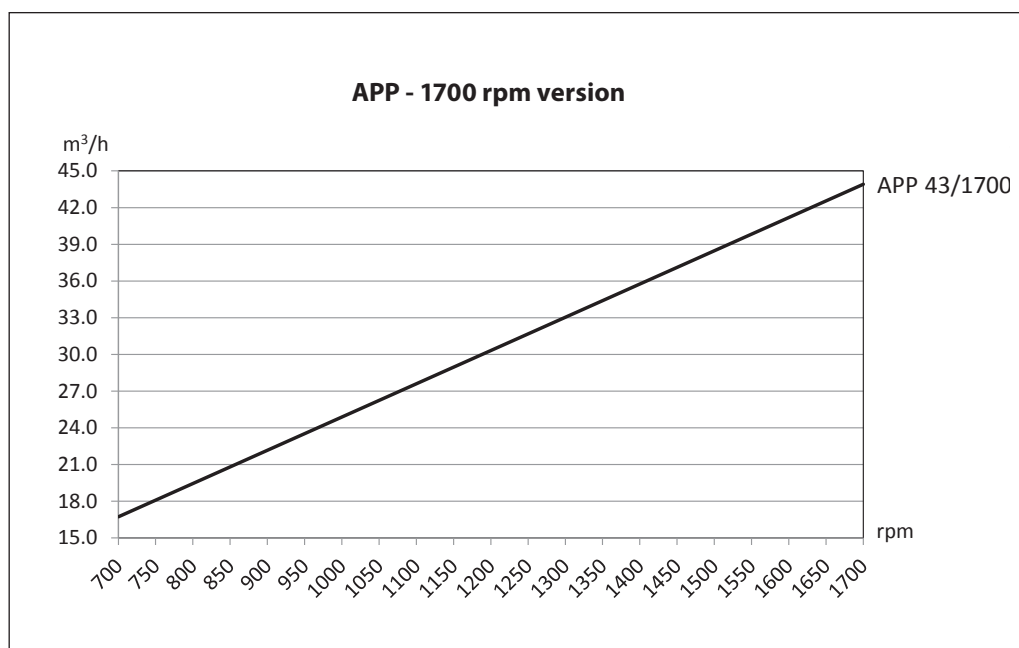

Furthermore, these diagrams shows that the flow can be changed by changing the rotation speed of the pump. The flow/rpm ratio is constant, and the "required" flow can be obtained by changing the rotation speed to a corresponding value. Thus, the required rpm can be determined as:

$$\text{Required rpm} = \frac{\text{Required flow} \times \text{Rated rpm}}{\text{Rated flow}}$$

6. Flushing valve

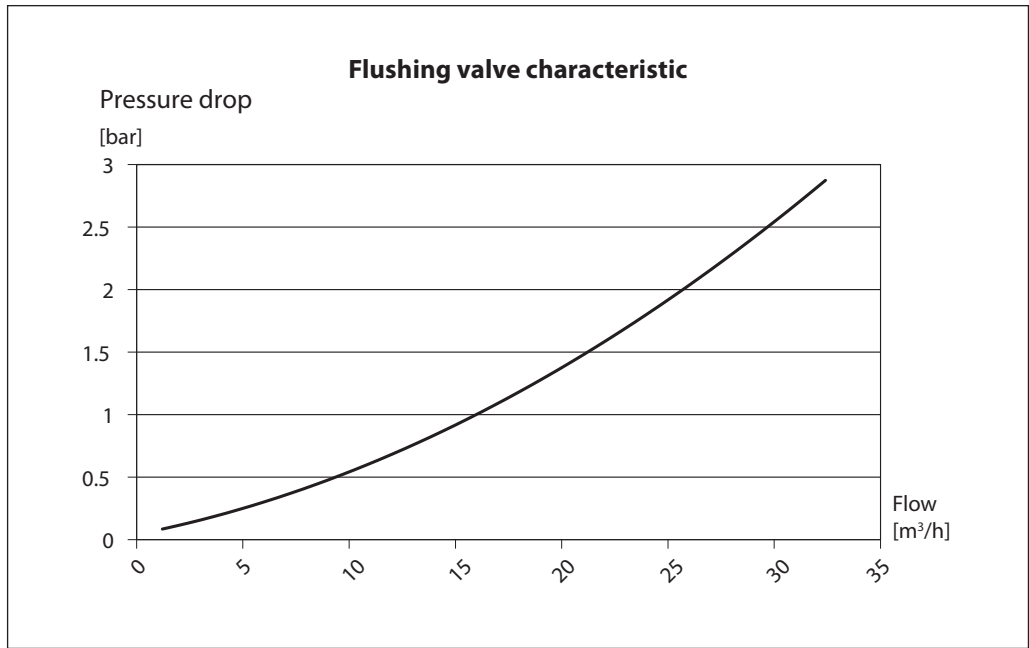

7. Power requirements

Pump model	Flow			Pressure			rpm	Calc. factor
	l/min	m³/h	gpm	60 bar	70 bar	80 bar		
				870 psi	1,015 psi	1,160 psi		
APP 21/1200	352	21.1	92.9	41 kW	48 kW	55 kW	1200	516
APP 21/1500	365	21.9	96.4	44 kW	52 kW	59 kW	1500	498
APP 24/1200	412	24.7	109	48 kW	56 kW	64 kW	1200	516
APP 24/1500	402	24.1	106.1	49 kW	57 kW	65 kW	1500	496
APP 26/1200	443	26.6	117.2	52 kW	61 kW	70 kW	1200	510
APP 26/1500	443	26.6	117.2	53 kW	62 kW	71 kW	1500	504
APP 30/1200	512	30.7	135.1	61 kW	71 kW	81 kW	1200	504
APP 30/1500	522	31.3	137.7	62 kW	73 kW	83 kW	1500	504
APP 38/1500	640	38.4	168.9	76 kW	88 kW	101 kW	1500	505
APP 43 / 1700	743	44.6	196.4	91 kW	106 kW		1700	503

The power requirements can be determined using one of the following guiding equations:

$$\text{Required power} = \frac{\text{l/min} \times \text{bar}}{\text{Calc. factor}} \text{ [kW]} \text{ or } \frac{16.7 \times \text{m}^3/\text{h} \times \text{bar}}{\text{Calc. factor}} \text{ [kW]} \text{ or } \frac{0.26 \times \text{gpm} \times \text{psi}}{\text{Calc. factor}} \text{ [kW]}$$

1 hp	=	0.75 kW
1 kW	=	1.34 hp
1 gpm	=	3.79 l/min
1 l/min	=	0.26 gpm
1 m³/h	=	4.40 gpm
1 gpm	=	0.23 m³/h

8. Temperature and corrosion

Fluid temperature: +2°C to +50°C (+35.6°F to 122°F) - dependent on the NaCl concentration
Ambient temperature: +2°C to +50°C (+35.6°F to 122°F)

8.1 Operation

The chart on the next page illustrates the corrosive resistance of different types of stainless steel related to NaCl concentration and temperature.

If the water pump is operated at high salinity, always flush the water pump with fresh water at operation stop in order to minimize the risk of crevice corrosion.

All critical parts of the APP water pump is made of Super Duplex.

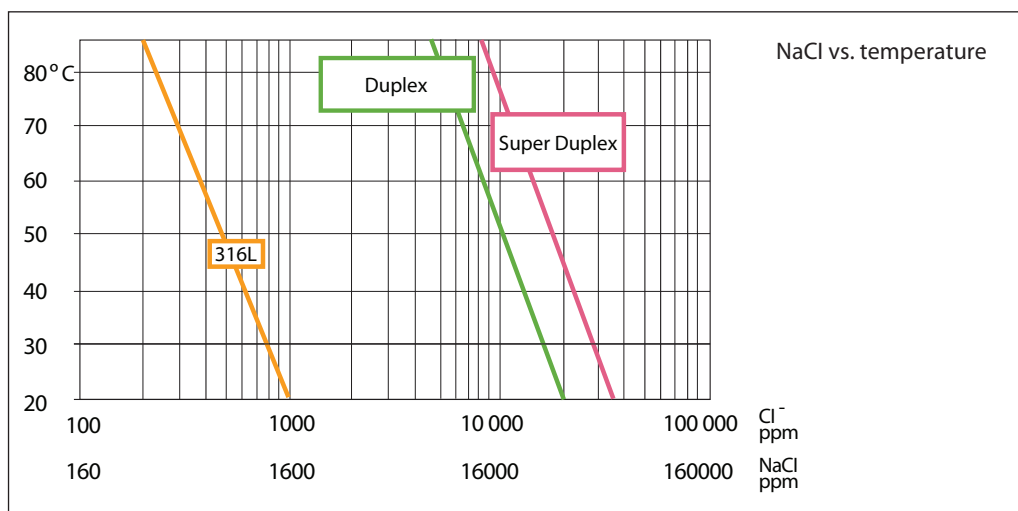

8.2 Storage

Storage temperature: -40°C to +70°C (+40°F to 158°F) – provided that the pump is drained of fluid and stored “plugged”.
--

Frost protection is required at temperatures below 2°C. Danfoss recommends to use DOW-FROST from DOW Chemical Company or Chilsafe mono propylene glycol from Arco Chemical Company.

9. Noise level

The sound pressure levels, L PA, 1m db(A)* for APP 21-38 pumps are typically 85 dB(A) at 80 bar/1500 rpm. For APP 43 the sound pressure level, L PA, 1m db(A)* is 85.3 at 70 bar/1700 rpm. The sound pressure level for the APP 43 is including a rubber damper.

It is therefore very important that the motor/pump unit is mounted correctly on a frame with anti-vibration isolation to minimize vibrations and noise.

Generally, noise will be reduced if speed is reduced and vice versa. Use flexible hoses in order to minimize vibrations and noise.

The noise level is influenced by:

- The speed of the pump, high rpm create more noise than low rpm
- Rigid mounting of the pump generates more noise than flexible mounting
- Pipe mounting direct to the pump increases the noise level compared to a flexible hose
- If using a VFD the motors can produce higher noise values depending on the operation point.

Since the pump is typically mounted on a bell housing or frame, the noise level must be determined for the complete unit (system).

* Measurements according to EN ISO 3744 : 2010 dB(A)LPA, 1m) values is calculated according to EN ISO 20361 section 6.2.

10. Filtration

As water has very low viscosity, the APP pumps have been designed with very narrow clearance in order to control internal leakage rates and improve component performance. Therefore it is important that the inlet water is filtered properly to minimize the wear of the pump.

efficiency. This means that for each 100,000 particles reaching the filter, 50,000 particles pass through it compared to only 20 particles in a filter with an efficiency of 99.98%.

The main filter must have a filtration efficiency of 99.98% at 10 µm. We recommend to use precision depth filter cartridges rated 10µm abs. $\beta_{10} \geq 5000$ (equivalent to a filtration efficiency of 99.98%). Bag filters and string wound filter cartridges typically have only 50% filtration

For more information on the importance of proper filtration, please consult our publication "Filtration" (code number 521B1009), which also will provide you with an explanation of filtration definitions and a guidance on how to select the right filter.

11. Dimensions

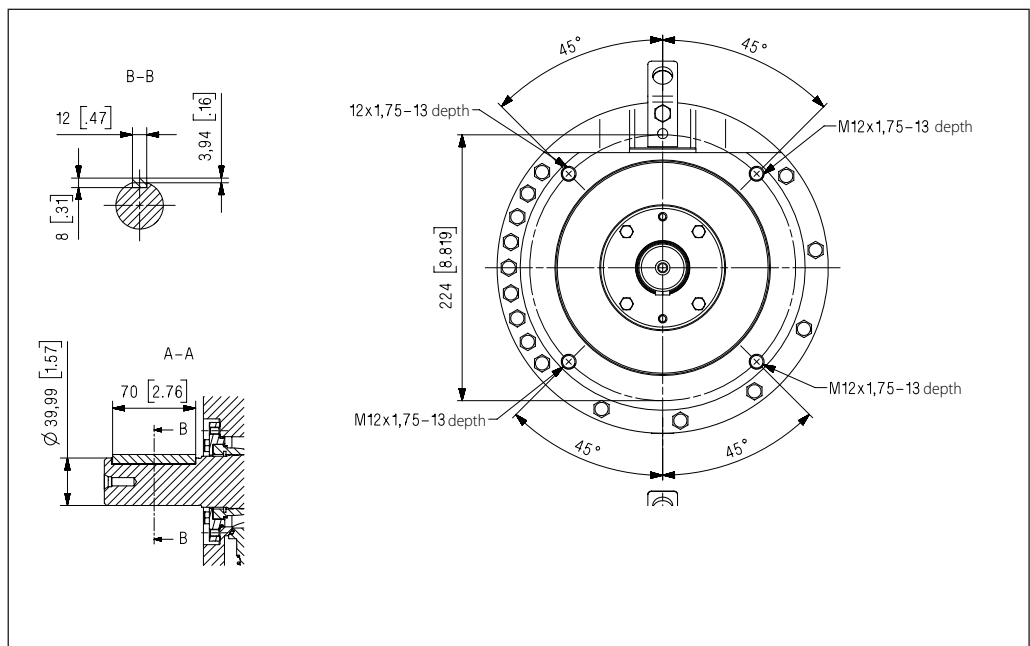
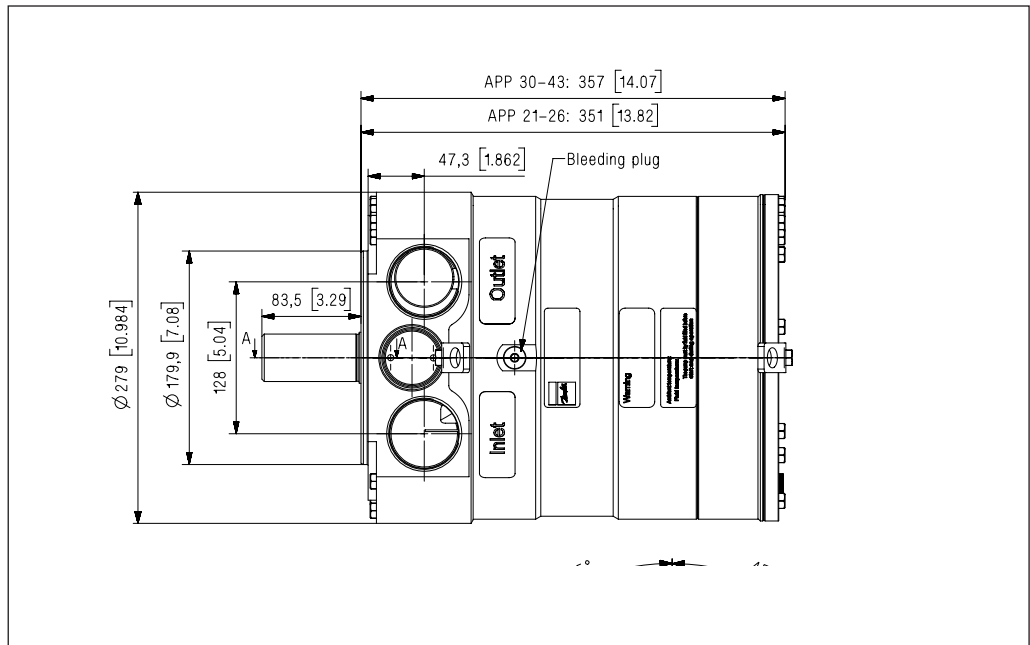

Description			APP 21 - APP 43
E	Parallel key, DIN 6885,	mm	12 × 8 × 70
		in	0.47 × 0.31 × 2.76
F	Bleeding	G ¼", Hexagon AF = 6 mm	
I	Inlet port	M60 x 1.5; depth 24 mm	
O	Outlet port	M60 x 1.5; depth 24 mm	
Mounting flange			ISO 3019-2 180B4TW

For more details on the accessories, please contact Danfoss High Pressure Pumps. Or check Data Sheets 521B1303/521B0909 available on website.

Accessories	Type	Code no.	
3" inlet hose kit	3" Victaulic	180Z0144	2.00 m [79"]
2" outlet hose kit APP 21-38	2½" Victaulic	180Z0263	1.78 m [70"]
		180Z0280	1.00 m [39.4"]
2½" outlet hose kit APP 43	2½" Victaulic	180Z0618	1.00 m [39.4"]
		180Z0619	1.78 m [70"]
2½" inlet connector APP 21-24	2½" Victaulic	180B3206	
3" inlet connector APP 21-43	3" Victaulic	180B3208	
Non-return valve (outlet) Duplex APP 21-38	2½" Victaulic (OD 73.1 mm)	180H0050	
Non-return valve (outlet) Super Duplex APP 21-38	2½" Victaulic (OD 73 mm)	180H0052	
Non-return valve (outlet) Super Duplex APP 21-43	2½" Victaulic (OD 73 mm)	180H0055	

12. Dimensions, complete unit

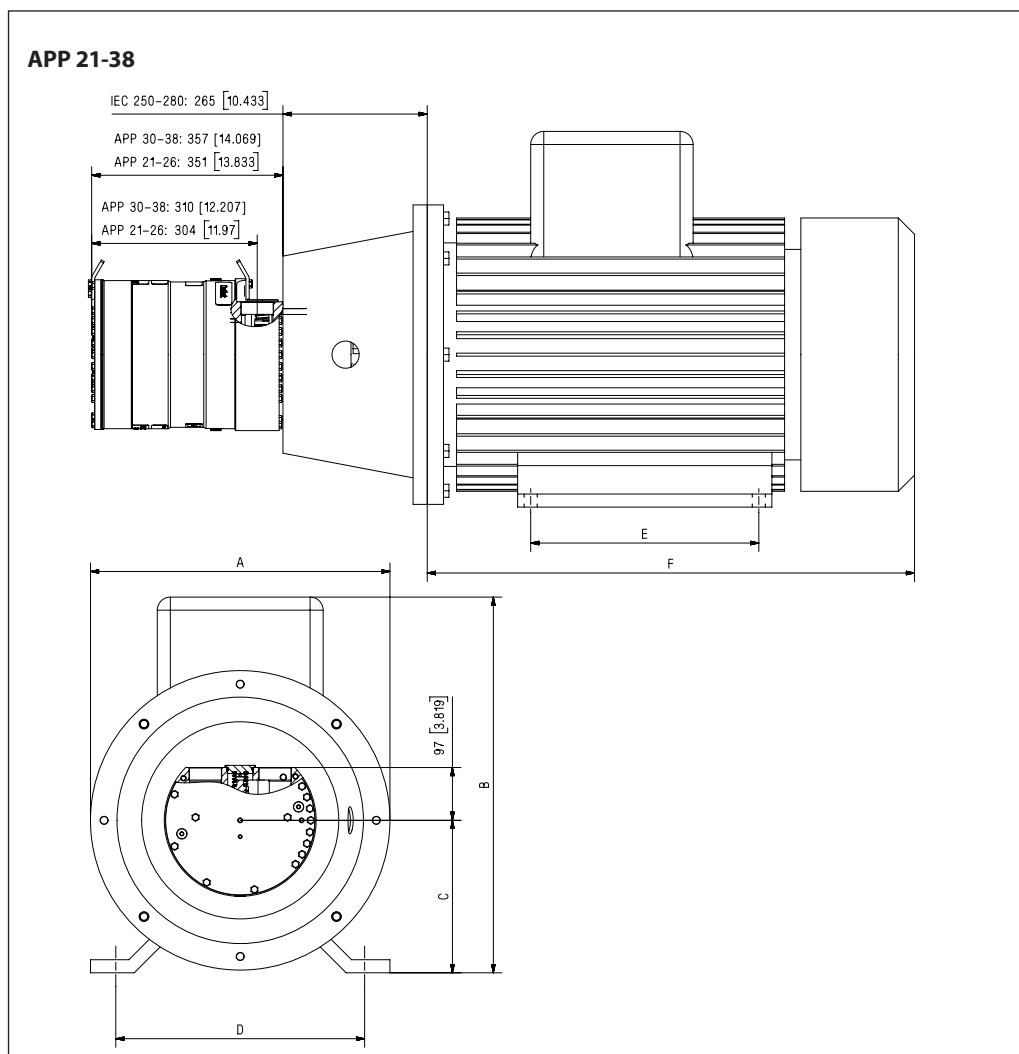

Pump	A (mm)	B (mm)	C (mm)	D (mm)	E (mm)	F (mm)	IEC Electric motor
APP 21-24	550	635	250	406	349	770	55 kW, IEC 250 M-4
APP 24-26	550	693	280	457	368	845	75 kW, IEC 280 S-4
APP 26-38	550	693	280	457	419	895	90 kW, IEC 280 M-4

Examples of different pump/motor sizes. Check required power.

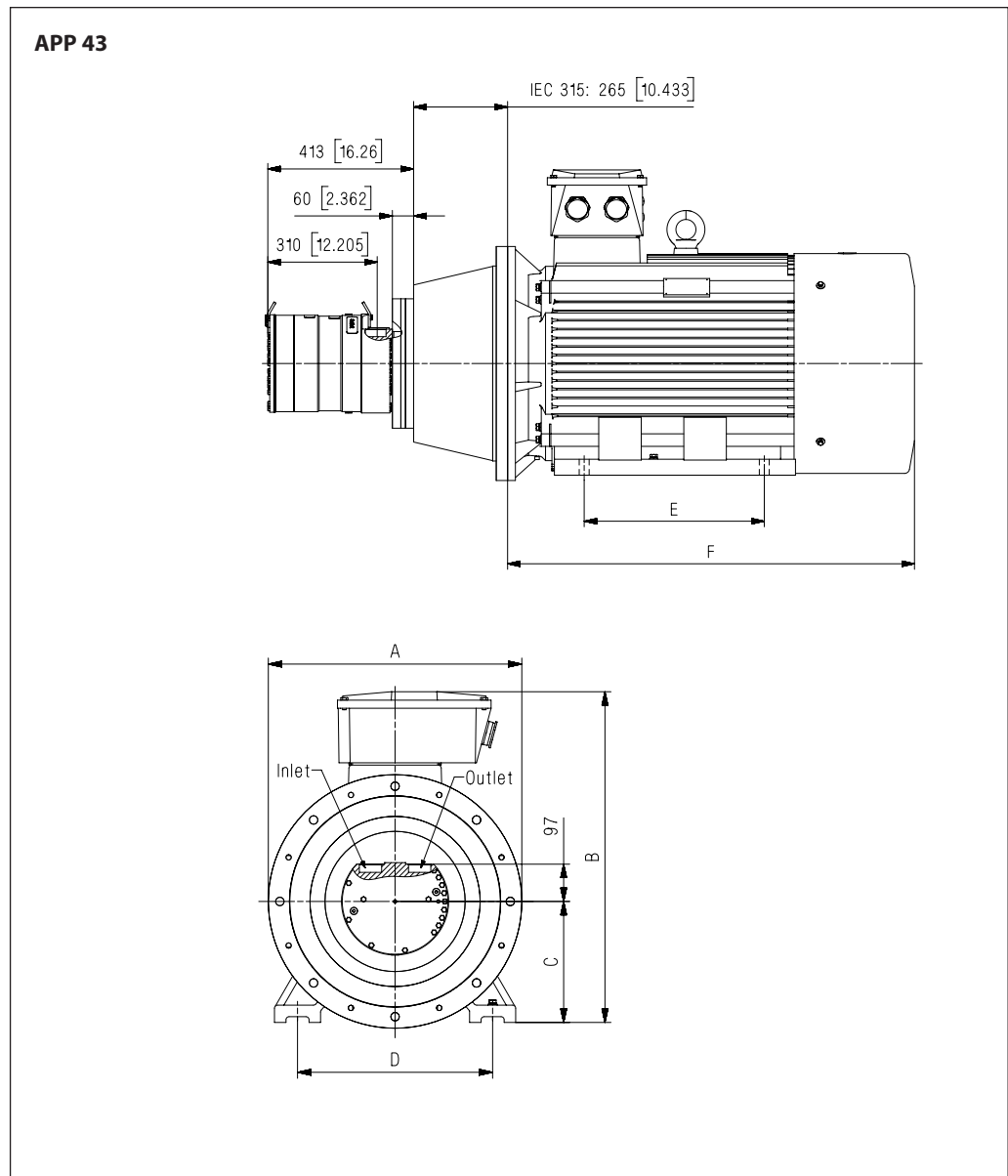

Pump	A (mm)	B (mm)	C (mm)	D (mm)	E (mm)	F (mm)	IEC Electric motor
APP 43	660	861	315	508	406	1038	110 kW, IEC 315 S-4

Above examples of different pump/motor sizes and drawing dimensions are only for IEC motors and couplings. Please make sure to check required motor power and dimensions when selecting size of pump and motor.

Due to the design and dimensions of an APP 43 pump, bell-housing and IEC motor, a dampening flange on the bell-housing is standard when an IEC 315 motor is selected.

If this dampening flange for some reason is deselected, an extension for the non-return valve may be needed in order to mount the pipe or hose with Victaulic clamps.

13. Installation

13.1 Mounting

The figure below illustrates how to mount the pump and connect it to the electric motor/ combustion engine.

If alternative mounting is required, please contact Danfoss High Pressure Pumps for further

information. To ensure easy mounting of the flexible coupling without using tools, the tolerances must be dimensioned accordingly.

Note: Any axial and radial loads on the pump shaft must be avoided.

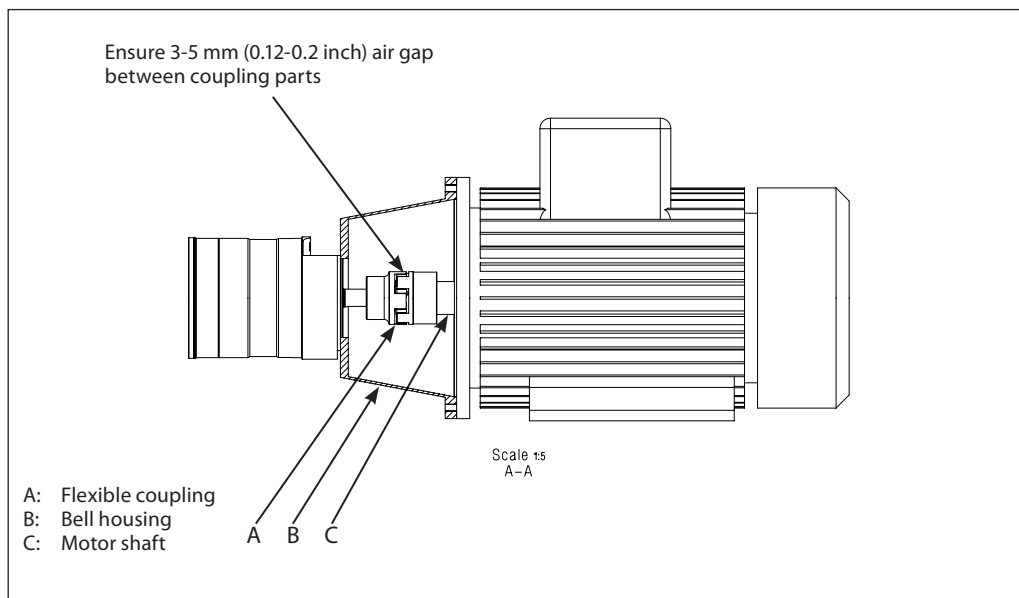

13.2 Open-ended system with direct water supply

In order to eliminate the risk of cavitation, a positive inlet pressure is always to be maintained. Please see technical data (section 3.) for specific pressure values.

1. Place the filter (1) in the water supply line in front of the pump.
2. Place a monitoring pressure switch (2) - set at min. inlet pressure - between filter and pump inlet. The monitoring switch must stop the pump at pressures lower than min. inlet pressure. Please see technical data (section 3.) for specific pressure values
3. Install a low pressure safety valve or a pressure relief valve (3) in order to avoid system or pump damage in case the pump stops momentarily or spinning backwards.

Note: If a non return valve is mounted in the inlet line, a low pressure relief valve is also required between non return valve and pump as protection against high pressure peaks.

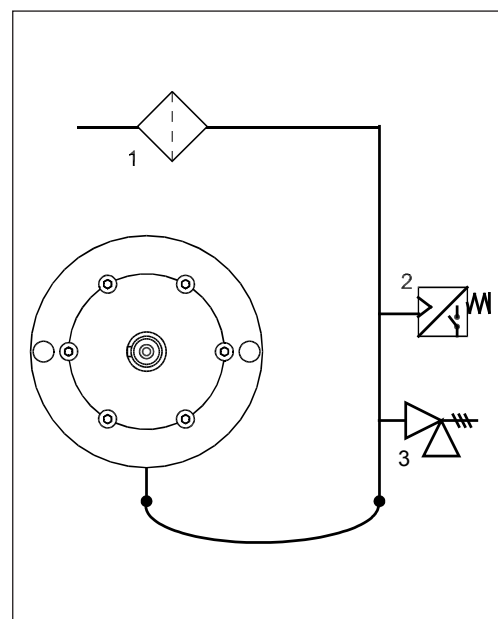

13.3 RO system with APP pump

1. Dimension the inlet line to obtain minimum pressure loss (large flow, minimum pipe length, minimum number of bends/connections, and fittings with small pressure losses).
2. Place an inlet filter (1) in front of the APP pump (2). Please consult section 10, "Filtration" for guidance on how to select the right filter. Thoroughly clean pipes and flush system prior to start-up.
3. Place a monitoring pressure switch (3) set at min. inlet pressure between filter and pump inlet. The monitoring switch must stop the pump at pressures lower than minimum pressure.
4. Use flexible hoses (4) to minimize vibrations and noise.
5. In order to eliminate the risk of damage and cavitation, a positive pressure at the inlet (5) is always to be maintained at min. inlet pressure and max. inlet pressure. Recommend to install safety valve or a

6. For easy system bleeding and flushing, a bypass non-return valve (6) is integrated in the APP pump.
7. A non-return valve (7) in outlet can be installed in order to avoid backspin of the pump. The volume of water in the membrane vessel works as an accumulator and will send flow backwards in case of the pump stops momentarily.
8. A safety valve or a pressure relief valve (8) can be installed in order to avoid system damage as the Danfoss APP pump creates pressure and flow immediately after start-up, regardless of any counterpressure.

Note: If a non return valve is mounted in the inlet line, a low pressure relief valve is also required between non return valve and pump as protection against high pressure peaks.

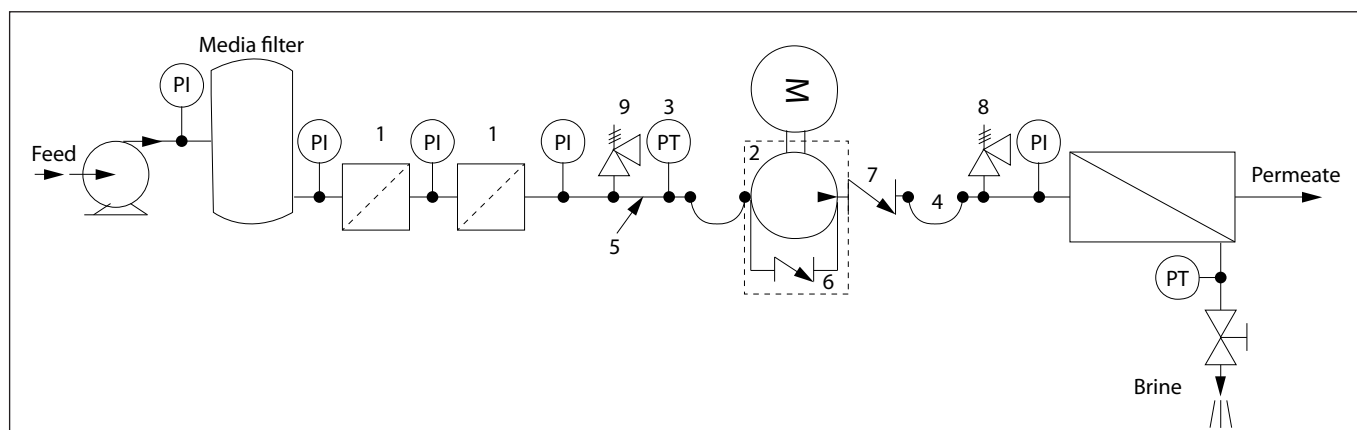

14. Service

14.1 Warranty

Danfoss APP pumps are designed for long operation, low maintenance and reduced lifecycle costs.

Provided that the pump has been running according to the Danfoss specifications, Danfoss guarantees 8,000 hours service-free operation, however, max. 18 months from date of production.

If Danfoss recommendations concerning system-design are not followed, **it will strongly influence the life of the APP pumps.**

14.2 Maintenance

After 8,000 hours of operation **it is strongly recommended to inspect the pump and change any worn parts, e.g. pistons and shaft seal.** This is done in order to prevent a potential breakdown of the pump.

If the parts are not replaced, more frequent inspection is recommended according to our guidelines.

Standstill

The APP pumps are made of Duplex/Super Duplex materials with excellent corrosion properties. **It is, however, always recommended to flush the pump with freshwater when the system is shut down.**

14.3 Repair

In case of irregular function of the APP, please contact Danfoss High Pressure Pumps.

Danfoss A/S
High Pressure Pumps
DK-6430 Nordborg
Denmark

Danfoss can accept no responsibility for possible errors in catalogues, brochures and other printed material. Danfoss reserves the right to alter its products without notice. This also applies to products already on order provided that such alterations can be made without subsequential changes being necessary in specifications already agreed. All trademarks in this material are property of the respective companies. Danfoss and the Danfoss logotype are trademarks of Danfoss A/S. All rights reserved.
