



Model 7CP6171 Shown
(Rails and shaft protector sold separately)

FEATURES

- 316SS head with optional FPM and EPDM elastomers offer compatibility with a wide range of liquids.
- Flexible coupling/bell housing, gearbox and belt drive options provide flexibility with a compact footprint.
- Rugged continuous-duty triplex design provides long life and low maintenance.
- Special flushed manifold with 7CP6111C and 7CP6171C permits external flush for added cooling with high temperature liquids and lubrication with low lubricity liquids.

COMMON SPECIFICATIONS

Inlet Pressure Range.....	Flooded to 70 psi	(Flooded to 4.9 bar)
Bore	0.866"	(22 mm)
Crankcase Capacity.....	38 oz.	(1.15 l)
Maximum Liquid Temperature	140°F	(60°C)
Above 130°F call Cat Pumps for inlet conditions and elastomer recommendations.		
Inlet Ports (2).....	3/4" NPTF	(3/4" NPTF)
Discharge Ports (2).....	1/2" NPTF	(1/2" NPTF)
Flushing Ports (2) (7CP6111C, 7CP6171C).....	1/8" NPTF	(1/8" NPTF)
Shaft Diameter	0.945"	(24 mm)
Weight (7CP6111, 7CP6171).....	29.1 lbs.	(13.2 kg)
Weight (7CP6111G1).....	38.6 lbs.	(17.5 kg)
Dimensions	13.45 x 9.26 x 6.89"	(342 x 235 x 175 mm)
Dimensions w/Gearbox.....	13.45 x 12.89 x 8.19"	(342 x 327 x 208 mm)

⚠ CAUTIONS AND WARNINGS

All High Pressure Systems require a primary pressure regulating device (i.e. regulator, unloader) and a secondary pressure relief device (i.e. pop-off valve, relief valve). Failure to install such relief devices could result in personal injury or damage to pump or property. CAT PUMPS does not assume any liability or responsibility for the operation of a customer's high pressure system.

Read all CAUTIONS and WARNINGS before commencing service or operation of any high pressure system. The CAUTIONS and WARNINGS are included in each service manual and with each Accessory Data sheet. CAUTIONS and WARNINGS can also be viewed online at www.catpumps.com/cautions-warnings or can be requested directly from CAT PUMPS.

WARRANTY

View the Limited Warranty on-line at www.catpumps.com/warranty.

7CP Stainless Steel Plunger Pump

Direct-Drive **7CP6111**
Standard and Flushed **7CP6111C**

Belt-Drive **7CP6171**
Standard and Flushed **7CP6171C**

Gearbox Model **7CP6111G1**

SPECIFICATIONS

U.S. Measure Metric Measure

MODEL 7CP6111, 7CP6111C

Flow	10.5 gpm	(40 l/m)
Pressure Range.....	100 to 2000 psi	(7 to 140 bar)
Pump RPM	1750 rpm	(1750 rpm)
Stroke.....	0.854"	(21.7 mm)

MODEL 7CP6171, 7CP6171C

Flow	10.5 gpm	(40 l/m)
Pressure Range.....	100 to 2000 psi	(7 to 140 bar)
Pump RPM	1450 rpm	(1450 rpm)
Stroke.....	1.024"	(26 mm)

MODEL 7CP6111G1

Flow	10.0 gpm	(38 l/m)
Pressure Range.....	100 to 2000 psi	(7 to 140 bar)
Pump RPM	1667 rpm	(1667 rpm)
Engine RPM	3400 rpm	(3400 rpm)
Stroke.....	0.854"	(21.7 mm)

ELECTRIC HORSEPOWER REQUIREMENTS

MODELS	FLOW		PRESSURE			MOTOR PULLEY SIZE Using 1725 rpm Motor & Std. 9.75" Pump Pulley	
			psi 1500	psi 1800	psi 2000		
	U.S. gpm	lpm	bar 105	bar 125	bar 140	rpm	Pulley O.D.
7CP6111 7CP6111C	10.5	40.0	10.8	12.9	14.4	1750	Direct-Drive
7CP6171	10.5	40.0	10.8	12.9	14.4	1450	8.4
7CP6171C	10.0	38.0	10.3	12.4	13.7	1318	7.6
7CP6111G1	10.0	38.0	Consult	Eng.	Mfg.	1667	Gearbox

DETERMINING THE PUMP RPM $\frac{\text{Rated gpm}}{\text{Rated rpm}} = \frac{\text{"Desired" gpm}}{\text{"Desired" rpm}}$

DETERMINING THE REQUIRED H.P. $\frac{\text{gpm} \times \text{psi}}{1460} = \text{Electric Brake H. P. Required}$

DETERMINING MOTOR PULLEY SIZE $\frac{\text{Motor Pulley O.D.}}{\text{Pump rpm}} = \frac{\text{Pump Pulley O.D.}}{\text{Motor rpm}}$

See complete Drive Packages (Incls: Pulleys, Belts, Hubs, Key) Tech Bulletin 003. Refer to pump **Service Manual** for repair procedure and additional technical information.

PARTS LIST

ITEM	P/N	MATL	DESCRIPTION	QTY
2	30067	STL	Key (M8x7.5x25)	1
5	49651	S	Screw, HHC Sems (M8x20)	8
8	49501	AL	Cover, Bearing	1
9	49503	FBR	Shim, Split, 2-Pc, Outer	0-2
10	12393	NBR	O-Ring, Bearing Cover - 70D	2
11	49190	NBR	Seal, Oil Crankshaft - 70D	1/2
12	49504	S	Shim, Split, 2-Pc, Inner	0-2
15	63479	STL	Bearing, Roller	2
20	48727	TNM	Rod, Connecting Assy [2/03]	3
25	49498	FCM	Crankshaft, Single-End (M21.7) (7CP6111, 7CP6111C, 7CP6111G1)	1
	49649	FCM	Crankshaft, Single-End (M26) (7CP6171, 7CP6171C)	1
30	48527	AL	Cover, Blind Bearing	1
31	828710	PE	Protector, Oil Cap w/Foam Gasket	1
32	43211	ABS	Cap, Oil Filler	1
33	14177	NBR	O-Ring, Oil Filler Cap - 70D	1
36	129343	RBR	Gasket, Flat	1
37	92241	—	Gauge, Oil, Bubble w/Gasket - 80D	1
38	44428	NBR	Gasket, Flat, Oil Gauge - 80D	1
39	49948	ABS	Stick, Dip	1
40	92538	S	Screw, HHC Sems (M6x16)	4
48	25625	STCP	Plug, Drain (1/4"x19BSP)	1
49	23170	NBR	O-Ring, Drain Plug - 70D	1
50	46959	AL	Cover, Rear	1
51	14030	NBR	O-Ring, Rear Cover - 70D	1
53	48577	AL	Crankcase	1
64	46969	CM	Pin, Crosshead	3
65	49637	SS	Rod, Plunger	3
70	48281	NBR	Seal, Oil Crankcase - 70D	3
75	43328	S	Slinger, Barrier	3
90	48559	CC	Plunger, Ceramic (M22x55)	3
95	49639	SS	Stud, Plunger Retainer (M6x50)	3
96	43235	PTFE	Back-up-Ring, Plunger Retainer	3
97	17399	NBR	O-Ring, Plunger Retainer - 80D	3
	14160	FPM	O-Ring, Plunger Retainer - 80D	3
	◆ 46204	EPDM	O-Ring, Plunger Retainer - 70D	3
98	44041	SS	Gasket	3
99	44031	SS	Retainer, Plunger (M6)	3
100	46964	NY	Retainer, Seal	3
106	49644	NBR	Seal, LPS w/SS-Spg	3
	49704	FPM	Seal, LPS w/SS-Spg	3
	◆ 48650	EPDM	Seal, LPS w/SS-Spg	3
120	49643	SS	Case, Seal	3
121	13984	NBR	O-Ring, Seal Case - 70D	3
	14333	FPM	O-Ring, Seal Case	3
	◆ 48649	EPDM	O-Ring, Seal Case	3
127	48278	STG*	V-Packing	6
128	49646	SS	Adapter, Male	6
162	43248	PTFE	Back-up-Ring, Seat	6
163	43249	NBR	O-Ring, Seat - 80D	6
	44383	FPM	O-Ring, Seat - 70D	3
	◆ 46206	EPDM	O-Ring, Seat - 70D	6
164	44037	SS	Seat	6
166	44038	SS	Valve	6
167	44039	SS	Spring	6
168	44564	PVDF	Retainer, Spring	6
172	17617	NBR	O-Ring, Valve Plug - 90D	6
	11691	FPM	O-Ring, Valve Plug - 90D	6
	◆ 46207	EPDM	O-Ring, Valve Plug - 70D	6
174	49293	SS	Plug, Valve	6
185	49641	SS	Head, Manifold	1
	49972	SS	Head, Manifold Flushed (1/8" Flushed Port)	1
188	49647	S	Screw, HSH (M8x70)	8
260	30613	STZP R	Mount, Rail, Assy	1
269	30206	F	Pulley (10") [See Tech Bulletin 003]	1
274	33000	STL	Hub, "H", M24 (Keyway M8) [See Tech Bulletin 003]	1
277	31570	AL	Bell Housing Assy, (184TC, 213-215TC, 20 Hp)	1
278	8370	STL	Flexible Coupling Assy (M24 x 1-1/8") (184TC)	1
	8375	STL	Flexible Coupling Assy (M24 x 1-3/8") (213-215T)	1
	8380	STL	Flexible Coupling Assy (M24 x 1-5/8") 254T)	1

EXPLODED VIEW

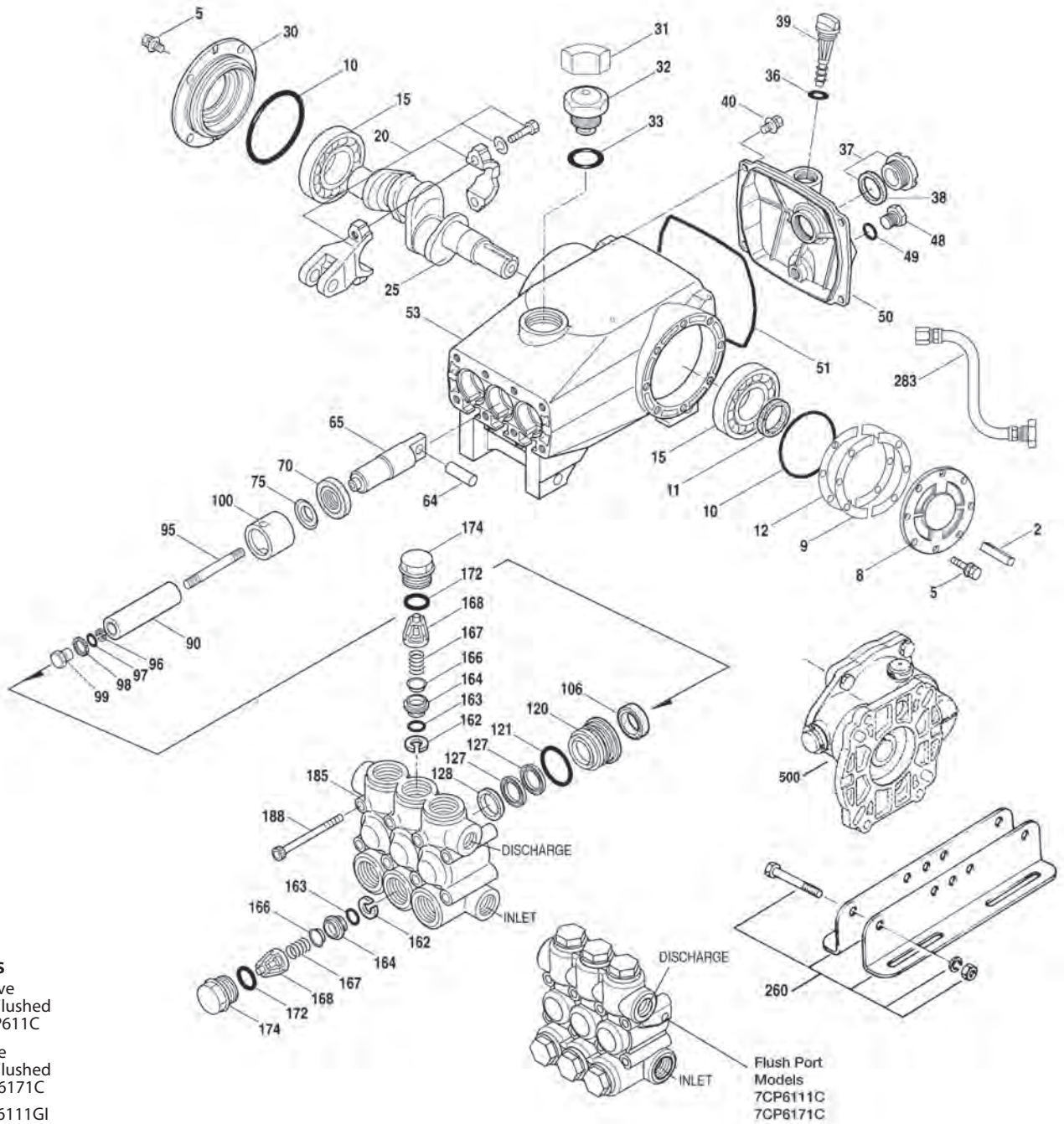

Models

Direct-Drive
Standard and Flushed
7CP6111, 7CP611C

Belt-Drive
Standard and Flushed
7CP6171, 7CP6171C

Gearbox - 7CP6111GI
February 2013

Flush Port
Models
7CP6111C
7CP6171C

ITEM	P/N	MATL	DESCRIPTION	QTY
283	34334	—	Kit, Oil Drain (3/8"x24)	1
299	818456	SS	Head, Complete	1
300	76933	NBR*	Kit, Seal (Incls: 97, 106, 121, 127)	1
	76950	FPM*	Kit, Seal (Incls: 97, 106, 121, 127) 7CP6111.0110, 7CP6111GI.0110	1
	◆ 31936	EPDM*	Kit, Seal (Incls: 97, 106, 121, 127) 7CP6111.0220	1
310	76387	NBR	Kit, Valve Pre-Assembled (Incls: 162, 163, 164, 166, 167, 168, 172)	2
	76940	FPM	Kit, Valve Pre-Assembled (Incls: 162, 163, 164, 166, 167, 168, 172) 7CP6111.0110, 7CP6111GI.0110	2
	◆ 76258	EPDM	Kit, Valve Pre-Assembled (Incls: 162, 163, 164, 166, 167, 168, 172) 7CP6111.0220	2
500	8081	—	Gearbox (See Individual Data Sheet)	1
—	6119	—	Lubricant, Antiseize (2 oz.) [See Tech Bulletin 095]	1
—	6107	—	Oil, Bottle (21 oz.) ISO 68 Hydraulic (Fill to specified crankcase capacity prior to start-up)	1-2

Bold print part numbers are unique to a particular pump model. Italics are optional items. [] Date of latest production change. ◆ Silicone oil/grease required.

R Components comply with RoHS Directive. *Review individual parts in each kit for material code identification.

View Tech Bulletins 002, 003, 024, 036, 043, 053, 064, 074, 077, 083 and 095 for additional information.

*MATERIAL CODES (Not Part of Part Number): ABS=ABS Plastic AL=Aluminum CC=Ceramic CM=Chrome-moly

EPDM=Ethylene Propylene Diene Monomer F=Cast Iron FBR=Fiber FCM=Forged Chrome-moly NBR=Medium Nitrile (Buna-N) NY= Nylon PE=Polyethylene

PTFE=Pure Polytetrafluoroethylene PVDF=Polyvinylidene Fluoride RBR= Rubber S=304SS SS=316SS STG=Special Blend PTFE White STL=Steel

STCP=Steel/Chrome Plated STZP=Steel/Zinc Plated TNM=Special High Strength

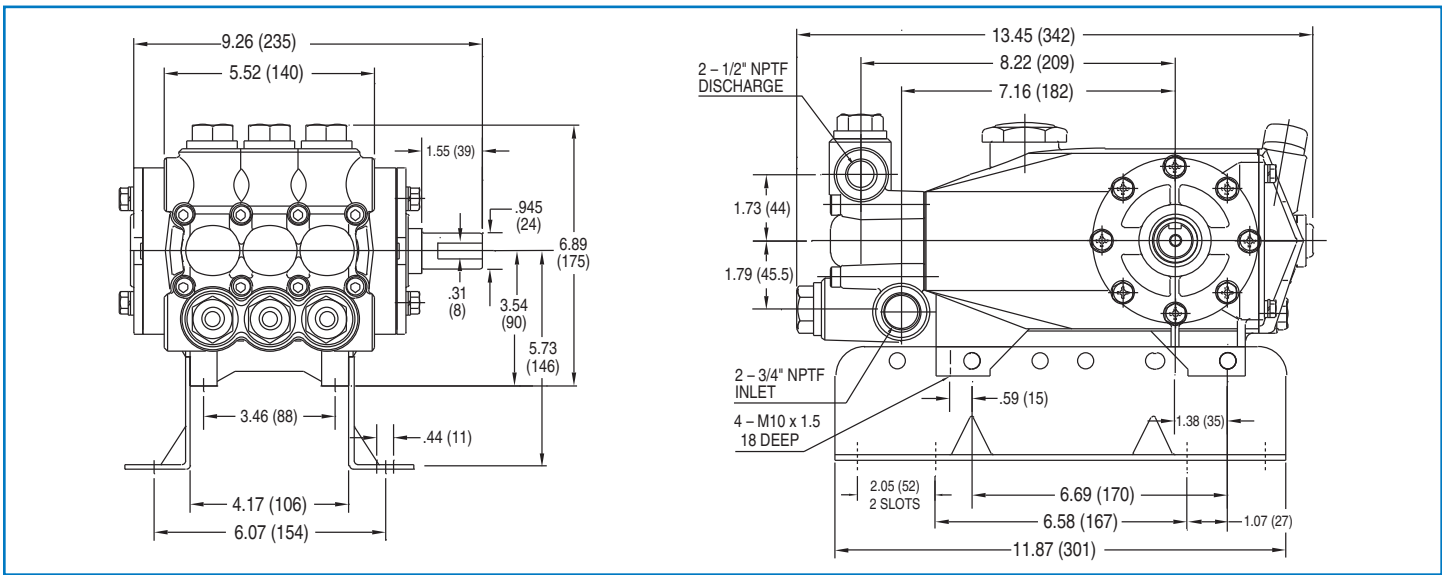

Models 7CP6111 and 7CP6171

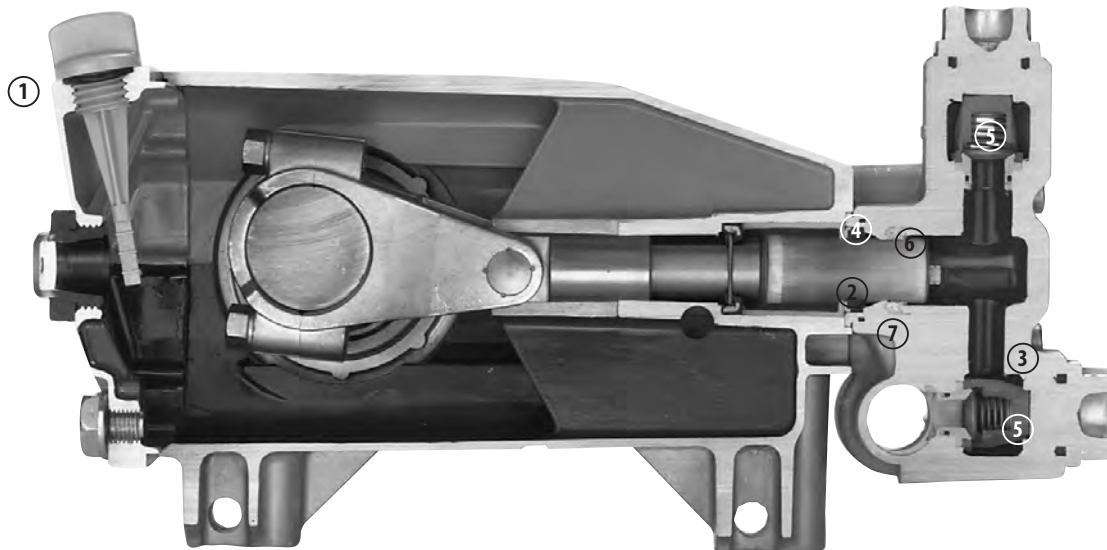

- 1 **Dipstick** offers optional top access in addition to rear bubble oil gauge for easy oil level check.
- 2 Special concentric, high-density, polished, solid ceramic **plungers** provide a true wear surface and extended seal life.
- 3 **Manifold** is a high tensile strength 316 stainless steel for strength and corrosion-resistance.
- 4 100% wet **seal** design adds to service life by allowing pumped liquids to cool and lubricate on both sides.
- 5 316 Stainless steel **valve** and seats are with hardened and polished for ultimate seating and extended life.
- 6 Exclusive specially formulated **V-Packings** offer unmatched performance and seal life.
- 7 Press-in style **seal case** offers alignment and support for seals and “no tools” servicing.
- 8 Special **flushed manifold** permits external flush for added cooling with high temperature liquids and lubrication with low lubricity liquids. (Not Shown)



CAT PUMPS
 1681 - 94TH LANE N.E. MINNEAPOLIS, MN 55449-4324
 PHONE (763) 780-5440 — FAX (763) 780-2958
 e-mail: techsupport@catpumps.com
 www.catpumps.com