

60 Frame Plunger Pump

Nickel Aluminum
Bronze Model

6747

FEATURES

- Triplex plunger design delivers high efficiency and low pulsation.
- Durable dual V-Packings are lubricated and cooled by pumped liquid.
- Pre-set Lo-Pressure Seals provide secondary protection against external leaks and require no packing adjustment.
- Special high-density, polished, concentric plungers provide a true wear surface and extended seal life.
- Specially formulated Seals and V-Packings offer unmatched performance and extended life.
- Wet-end easily serviced without entering crankcase.

SPECIFICATIONS

	U.S. Measure	Metric Measure
Flow	48 gpm	(182 l/m)
Pressure Range	100 to 2000 psi	(7 to 140 bar)
RPM	615 rpm	(615 rpm)
Inlet Pressure Range	Flooded to 50 psi	(Flooded to 3.5 bar)
Bore	1.772"	(45 mm)
Stroke	2.579"	(65.5 mm)
Crankcase Capacity	10 Qts.	(9.46 l)
Maximum Liquid Temperature	140°F	(60°C)
Above 130°F call CAT PUMPS for inlet conditions and elastomer recommendations.		
Inlet Ports (2)	2" NPTF	(2" NPTF)
Discharge Ports (2)	1-1/4" NPTF	(1-1/4" NPTF)
Shaft Diameter	1.772"	(45 mm)
Weight	335 lbs.	(151.95 kg)
Dimensions	31.14 x 24.37 x 12.87" (791 x 619 x 327 mm)	

ELECTRIC HORSEPOWER REQUIREMENTS

FLOW		PRESSURE				RPM
		psi 900	psi 1000	psi 1200	psi 2000	
U.S. gpm	l/m	bar 60	bar 70	bar 85	bar 140	
48	182	29.6	32.9	39.4	65.8	615

DETERMINING THE PUMP R.P.M.	$\frac{\text{Rated gpm}}{\text{Rated rpm}}$	=	$\frac{\text{"Desired" gpm}}{\text{"Desired" rpm}}$
DETERMINING THE REQUIRED H.P.	$\frac{\text{gpm} \times \text{psi}}{1460}$	=	Electric Brake H. P. Required
DETERMINING MOTOR PULLEY SIZE	$\frac{\text{Motor Pulley O.D.}}{\text{Pump rpm}}$	=	$\frac{\text{Pump Pulley O.D.}}{\text{Motor rpm}}$

See complete Drive Packages [Incls: Pulleys, Belts, Hubs, Key] Tech Bulletin 003.
Refer to pump **Service Manual** for repair procedure and additional technical information.

⚠ CAUTIONS AND WARNINGS

All High Pressure Systems require a primary pressure regulating device (i.e. regulator, unloader) and a secondary pressure relief device (i.e. pop-off valve, relief valve). Failure to install such relief devices could result in personal injury or damage to pump or property. CAT PUMPS does not assume any liability or responsibility for the operation of a customer's high pressure system.

Read all CAUTIONS and WARNINGS before commencing service or operation of any high pressure system. The CAUTIONS and WARNINGS are included in each service manual and with each Data sheet. CAUTIONS and WARNINGS can also be viewed online at www.catpumps.com/cautions-warnings or can be requested directly from CAT PUMPS.

WARRANTY

View the Limited Warranty on-line at www.catpumps.com/warranty.

"Customer confidence is our greatest asset"

PARTS LIST

ITEM	P/N	MATL	DESCRIPTION	QTY
2	43048	STL	Key (M14x9x90)	1
5	89728	S	Screw, HH (M10 x 40)	8
6	15847	S	Lockwasher (M10)	8
7	19934	S	Washer, Flat (M10)	8
8	29443	AL	Cover, Bearing, Outer	2
10	29444	NBR	O-Ring, Bearing Case - 70D	2
11	11443	NBR	Seal, Oil, Crankshaft - 70D	2
12	43642	STZP R	Washer, Shim (M120 x 0.3), Bearing, Inner	0-2
13	126595	STZP R	Washer, Shim (M120 x 0.5), Bearing, Inner	0-2
15	29441	STL	Bearing, Roller	2
16	29442	STL	Cover, Bearing, Inner	2
17	29444	NBR	O-Ring, Bearing Case - 70D	2
20	126612	BBHS	Rod, Connecting (Incls: 21,22)	3
21	126560	STCP R	Washer, Locking	3
22	126593	STCP R	Washer, Shim (M10.5 x 1.5)	6
25	29440	FCM	Crankshaft, Dual End	1
31	828710	—	Protector, Oil Cap	1
32	43211	ABS	Cap, Oil Filler	1
33	14177	NBR	O-Ring, Oil Filler Cap - 70D	1
34	126743	STCP R	Bolt, Eye (M12x1.75) (For Lifting Pump Only) [1/00]	1
38	103686	RBR	Gasket, Flat	1
39	27769	ABS	Stick, Dip	1
40	89627	S	Screw, HH (M10 x 30)	8
41	15847	S	Lockwasher (M10)	8
42	19934	S	Washer, Flat (M10)	8
48	25625	STCP	Plug, Drain (1/4 x 19BSP)	1
49	23170	NBR	O-Ring, Drain Plug - 70D	1
50	29438	AL	Cover, Rear	1
51	129386	NBR	Gasket, Rear Cover	1
53	45303	AL	Crankcase (Incls: 34,54)	1
54	43282	S	Pin, Guide	2
55	89615	S	Stud (M16 x 70)	2
64	29481	CM	Pin, Crosshead	3
65	45384	SSZZ	Rod, Plunger	3
69	126588	STCP R	Washer, Oil Seal	3
70	29454	NBR	Seal, Oil - 80D	3
75	44752	NBR	Slinger, Barrier	3
88	45677	SS	Washers, Keyhole (M14)	3
90	45672	CC	Plunger (M45 x 185)	3
95	44748	SS	Stud, Plunger Retainer (M14 x 147)	3
96	20214	PTFE	Back-up-Ring, Plunger Retainer	3
97	17616	NBR	O-Ring, Plunger Retainer - 80D	3
	11686	FPM	O-Ring, Plunger Retainer - 80D	3
	◆ 703369	EPDM	O-Ring, Plunger Retainer - 70D	3
98	44751	SS	Gasket, Plunger Retainer	3
99	44750	SS	Retainer, Plunger (M14)	3
100	702014	PVDF	Retainer, Seal	3
104	18178	NBR	O-Ring, Inlet Adapter - 80D	3
	13338	FPM	O-Ring, Inlet Adapter - 70D	3
	◆ 701657	EPDM	O-Ring, Inlet Adapter - 70D	3
105	701355	SS	Adapter, LPS	3
106	106147	NBR	Seal, LPS w/SS-Spg	3
	701752	SFTA*	Seal, LPS w/SS-Spg	3
107	701580	D	Spacer, LPS	3
110	44754	NAB	Manifold, Inlet	1
112	18175	NBR	O-Ring, Spacer, Inner - 80D	3
	13266	FPM	O-Ring, Spacer, Inner - 70D	3
	◆ 702442	EPDM	O-Ring, Spacer, Inner - 75D	3
114	44767	SS	Spacer, Inlet Manifold	3
115	18175	NBR	O-Ring, Spacer, Outer - 80D	3
	13266	FPM	O-Ring, Spacer, Outer - 70D	3
	702442	EPDM	O-Ring, Spacer, Outer - 75D	3
116	19086	S	Lockwasher (M16)	4
117	89729	S	Screw, HH (M16 x 55)	4
123	18178	NBR	O-Ring, Cylinder V/P - 80D	3
	13338	FPM	O-Ring, Cylinder V/P - 70D	3
	◆ 701657	EPDM	O-Ring, Cylinder V/P - 70D	3
124	701357	SS	Cylinder, V/P	3
126	701358	SS	Adapter, Female	3
127	104450	STG*	V-Packing	6
128	701359	SS	Adapter, Male	3
155	701978	NBR	O-Ring, Spacer	3
	701360	FPM	O-Ring, Spacer	3
	◆ 702045	EPDM	O-Ring, Spacer	3

ITEM	P/N	MATL	DESCRIPTION	QTY
156	701361	PTFE	Back-up Ring, Spacer Inner	3
157	701362	SS	Spacer, V-Packing w/Coil Springs	3
158	701363	PTFE	Back-up Ring, Spacer Outer	3
159	18178	NBR	O-Ring, Spacer - 80D	3
	13338	FPM	O-Ring, Spacer - 70D	3
	◆ 701657	EPDM	O-Ring, Spacer - 70D	3
160	44756	S	Pin, Guide	2
163	18176	NBR	O-Ring, Seat - 80D	6
	13278	FPM	O-Ring, Seat	6
	◆ 702445	EPDM	O-Ring, Seat - 70D	6
164	44772	SS	Seat	6
166	44774	SS	Valve	6
167	44773	SS	Spring	6
168	44775	PVDF	Retainer, Spring	6
170	44776	SS	Washer, Retainer	6
171	44780	SS	Spring, Coil, Valve Plug	6
172	18177	NBR	O-Ring, Valve Plug - 80D	6
	13279	FPM	O-Ring, Valve Plug - 70D	6
	◆ 701988	EPDM	O-Ring, Valve Plug	6
174	44778	NAB	Plug, Valve [3/00]	6
185	44769	NAB	Manifold, Discharge [3/00]	1
186	19086	S	Lockwasher (M16)	2
188	89694	S	Screw, HSH (M16 x 110)	8
194	81291	S	Nut, Hex (M16)	2
250	29445	AL	Protector, Shaft	1
255	33243	STZP	Kit, Mount (Included w/Pump)	1
259	29477	STZP	Rail (Included w/Pump) (Two per pump required)	2
275	990014	STL	Hub, 45mm (M14x9 Keyway) [See Tech Bulletin 003]	1
283	34314		Kit, Oil Drain (3/8" x 48")	1
290	6124		Gasket, Liquid (3.0 oz.)	1
299	702348	NAB	Head, Complete	1
300	702349	NBR*	Kit, Seal (Includes: 97,104,106,112,115,123,127,155,156,158,159)	1
	702350	FPM*	Kit, Seal (Includes 97,104,106,112,115,123,127,155,156,158,159)	1
	◆ 703545	EPDM*	Kit, Seal (Includes 97,104,106,112,115,123,127,155,156,158,159)	1
310	34092	NBR	Kit, Valve (Includes 163,164,166,167,168,170,172)	2
	31273	FPM	Kit, Valve (Includes 163,164,166,167,168,170,172)	2
	76092	EPDM	Kit, Valve (Includes 163,164,166,167,168,170,172)	2
	819010	F	Assy, Crankcase, Cast Iron Conversion	1
	88902	STZP	Stud (M16x277) (For removing D.M., I.M.)	2
390	717500	SS	C.A.T. (Inlet pressure stabilizer for R.O. and boosted inlet applications)	1
391	717508	SS	Adapters (2 per C.A.T.) (See Data Sheet for complete selection)	2
392	701833	SS	Elbow Assy used with Adapter Assembly 717508	1
	6105		Oil, Twin Pack (Two 2.5 Gal) ISO 68 Hydraulic (Fill to specified crankcase capacity prior to start-up)	1

Italics are optional items.

◆ Silicone Oil/Grease Required.

R Components comply with RoHS Directive.

[] Date of latest production change.

* Review individual parts in each kit for material code identification.

C.A.T. highly recommended for pressurized inlet, R.O. and Industrial applications.

View Tech Bulletins 003, 024, 036, 043, 052, 053, 054, 064, 074, 077, 082, 083 and 084 for additional information.

MATERIAL CODES (Not Part of Part Number): ABS=ABS Plastic AL=Aluminum CC=Ceramic CM=Chrome-Moly D=Acetal FCM=Forged Chrome-moly FPM=Fluorocarbon NAB=Nickel Aluminum Bronze NBR=Medium Nitrile (Buna-N) PTFE=Pure Polytetrafluoroethylene PVDF=Polyvinylidene Fluoride RBR=Rubber S=304SS SFTA=Special Blend PTFE Tan SS=316SS SSL=316SS/ Low Carbon SSZZ=316SS/Zamak STCP=Steel/Chrome Plated STG=Special Blend PTFE White STL=Steel STCP=Steel/Chrome Plated STZP=Steel/Zinc Plated

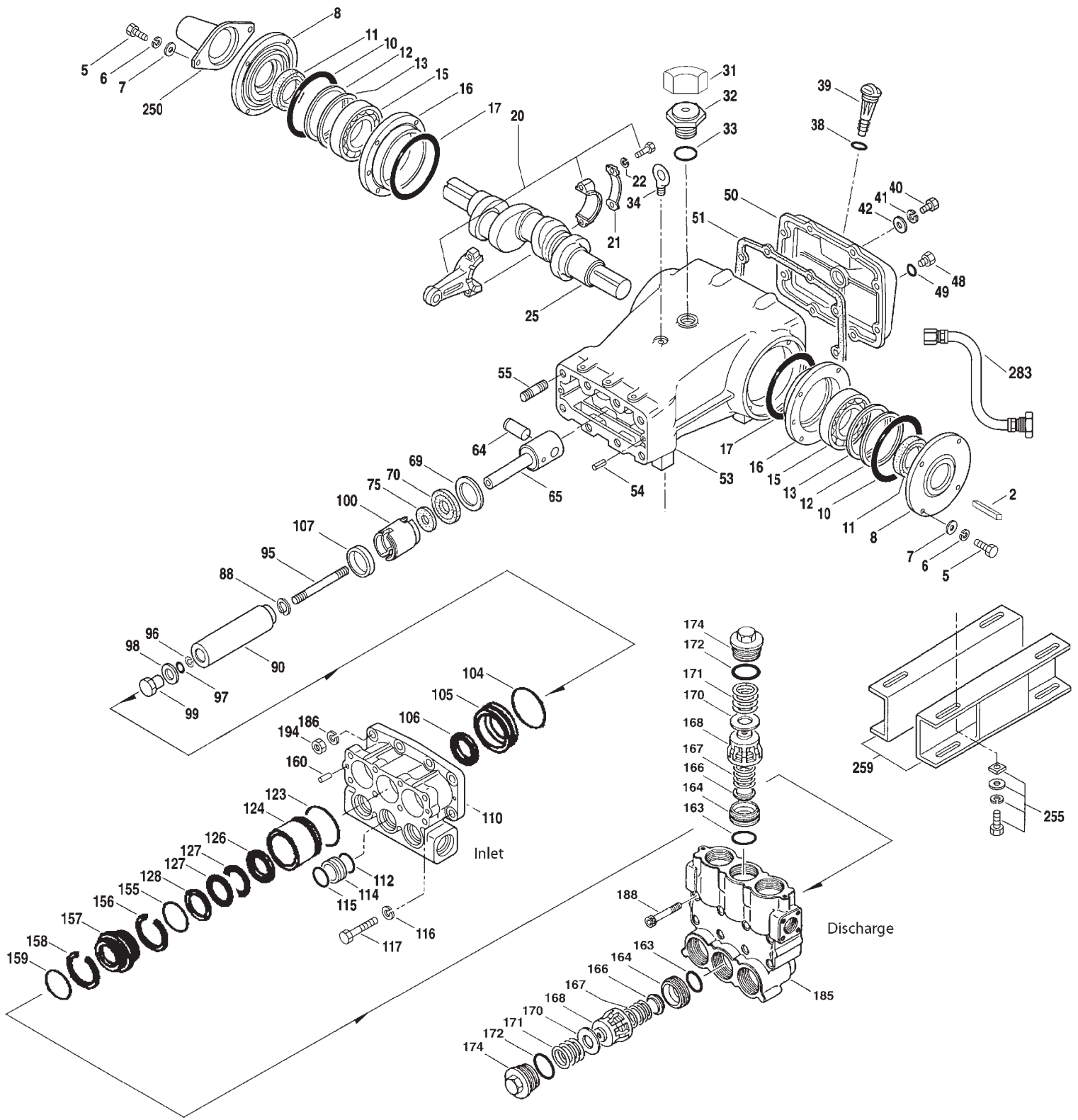

Model
 Nickel Aluminum Bronze - 6747
 June 2010

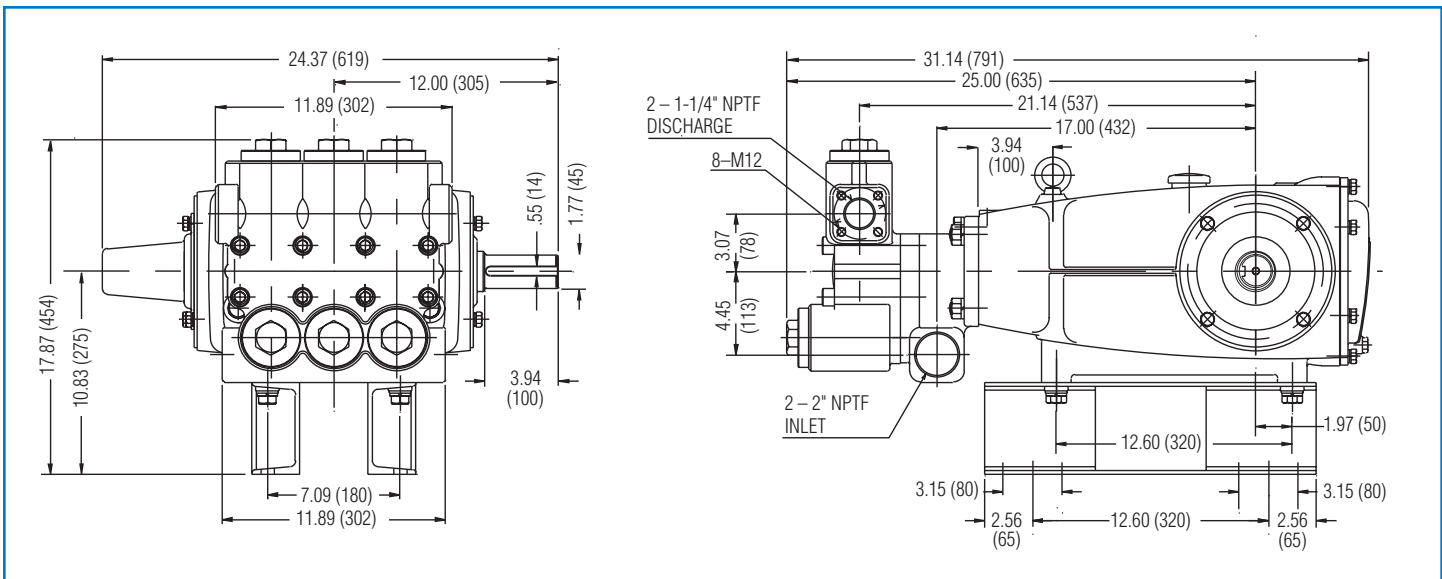

Model 6747

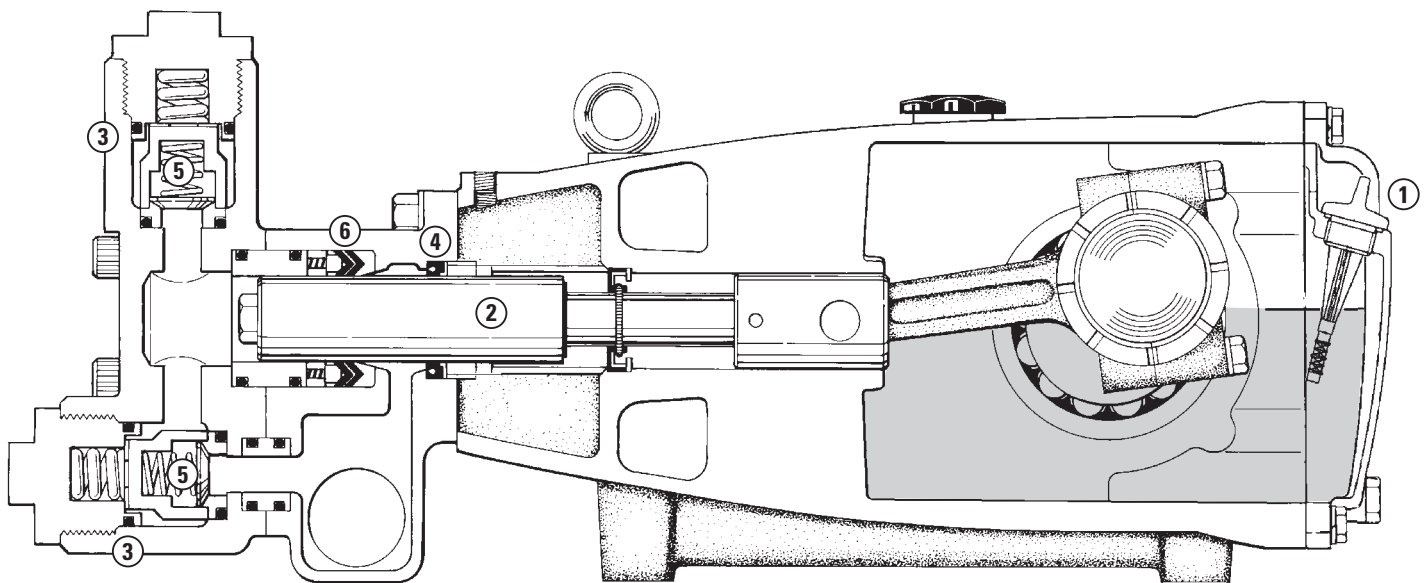

- 1 Dipstick offers convenient top access for easy oil level check.
- 2 Special concentric, high density, polished, solid ceramic **plungers** provide a true wear surface and extended seal life.
- 3 **Manifolds** are a high tensile strength nickel aluminum bronze for long term, continuous duty.
- 4 100% wet **seal** design adds to service life by allowing pumped liquids to cool and lubricate on both sides.
- 5 Stainless steel **valves, seats and springs** provide corrosion-resistance, positive seating and long life.
- 6 Specially formulated, Cat Pump exclusive, **V-Packings** offer unmatched performance and seal life.

World Headquarters

CAT PUMPS

1681 - 94th Lane N.E. Minneapolis, MN 55449 - 4324

Phone (763) 780-5440 — FAX (763) 780-2958

e-mail: techsupport@catpumps.com

www.catpumps.com

International Inquiries

FAX (763) 785-4329

e-mail: intlsales@catpumps.com



The Pumps with Nine Lives

CAT PUMPS (U.K.) LTD.

1 Fleet Business Park, Sandy Lane, Church Crookham

FLEET, Hampshire GU52 8BF, England

Phone Fleet 44 1252-622031 — Fax 44 1252-626655

e-mail: sales@catpumps.co.uk www.catpumps.co.uk

N.V. CAT PUMPS INTERNATIONAL S.A.

Heiveldekens 6A, 2550 Kontich, Belgium

Phone 32-3-450.71.50 — Fax 32-3-450.71.51

e-mail: cpi@catpumps.be www.catpumps.be

CAT PUMPS DEUTSCHLAND GmbH

Buchwiese 2, D-65510 Idstein, Germany

Phone 49 6126-9303 0 — Fax 49 6126-9303 33

e-mail: catpumps@t-online.de www.catpumps.de