

150 Frame R-Series Duplex Stainless Steel Reciprocating Process Pump

Models **157R060**
157R080

FEATURES

- Triplex design delivers high efficiency and low pulsation.
- Durable dual V-Packings are lubricated and cooled by pumped liquid.
- Pre-Set Lo-Pressure Seals provide secondary protection against external leaks and require no packing adjustment.
- Special high density, polished, concentric plungers provide a true wear surface and extended seal life.
- Specially formulated Seals and V-Packings offer unmatched performance and extended seal life.
- Ceramic plungers, Seals and V-Packings are serviceable from the top of the crankcase permitting easy in-field servicing.

COMMON SPECIFICATIONS

Inlet Pressure Range.....	Flooded to 50 psi	(Flooded to 3.5 bar)
Minimum rpm.....	75 rpm	(75 rpm)
Stroke.....	5.91"	(150 mm)
Crankcase Capacity.....	22.4 Gals	(85 l)
Lubrication.....	Splash	(splash)
Maximum Temperature.....	140°F	(60°C)
Inlet Ports (2) (Flange Required)	6.0"	(150 mm)
Discharge Ports (2) (Flange Required)	4.0"	(100 mm)
Shaft Diameter	3.397"	(100 mm)
Shaft Length.....	8.150"	(207 mm)
Weight.....	3087 Lbs	(1400 kg)
Dimensions.....	68.9 x 42.1 x 22"	(1750 x 1069 x 560 mm)

SPECIFICATIONS

	U.S. Measure	Metric Measure
STANDARD 157R060		
Flow	100 gpm	(378 l/m)
System Pressure*	2700 psi	(185 bar)
Maximum rpm.....	310 rpm	(310 rpm)
Bore	2.375"	(60.3 mm)

API

Flow	87 gpm	(329 l/m)
Barrels Per Day (U.S., Petroleum) 2983 bbl/d		(—)
System Pressure*	2700 psi	(185 bar)
Maximum rpm.....	270 rpm	(270 rpm)
Bore	2.375"	(60.3 mm)

STANDARD 157R080

Flow	200 gpm	(757 l/m)
System Pressure*	1560 psi	(108 bar)
Maximum rpm.....	355 rpm	(355 rpm)
Bore	3.150"	(80 mm)

API

Flow	152 gpm	(575 l/m)
Barrels Per Day (U.S., Petroleum) 5211 bbl/d		(—)
System Pressure*	1560 psi	(108 bar)
Maximum rpm.....	270 rpm	(270 rpm)
Bore	3.150"	(80 mm)

* Relief pressure should be set at maximum 10% over system pressure.

⚠ CAUTIONS AND WARNINGS

All High Pressure Systems require a primary pressure regulating device (i.e. regulator, unloader) and a secondary pressure relief device (i.e. pop-off valve, relief valve). Failure to install such relief devices could result in personal injury or damage to pump or property. CAT PUMPS does not assume any liability or responsibility for the operation of a customer's high pressure system.

Read all CAUTIONS and WARNINGS before commencing service or operation of any high pressure system. The CAUTIONS and WARNINGS are included in each service manual and with each Accessory Data sheet. CAUTIONS and WARNINGS can also be viewed online at www.catpumps.com/cautions-warnings or can be requested directly from CAT PUMPS.

WARRANTY

View the Limited Warranty on-line at www.catpumps.com/warranty.

ELECTRIC HORSEPOWER REQUIREMENTS

MODEL	FLOW		PRESSURE					RPM
			psi 1000	psi 1500	psi 2000	psi 2500	psi 2700	
	U.S. gpm	l/m	bar 70	bar 105	bar 140	bar 175	bar 185	
157R060	100	378	69	103	137	172	185	310
157R060 API	87	329	59	89	118	148	159	270
157R080	200	757	137	205	N/A	N/A	N/A	355
157R080 API	152	575	104	156	N/A	N/A	N/A	270

PARTS LIST

ITEM	PART NUMBER		DESCRIPTION		QTY	
2	157R060	MATL	157R080	MATL		
2	890602	STL	890602	STL	Key (M28x16x170)	1
3	891238	STL	891238	STL	Screw, Grub (M20x20)	4
4	891275	SS	891275	SS	Plate, Serial No. (Not Shown)	1
5	891228	STL	891228	STL	Screw, HH (M20x60)	10
8	891235	F	891235	F	Cover, Bearing	1
10	890215	FPM	890215	FPM	O-Ring, Bearing Cover - 70D	2
11	890270	NBR	890270	NBR	Seal, Oil	1
12	890230	POP	890230	POP	Shim Set	1
15	891240	STL	891240	STL	Bearing, Roller	2
20	891360	HS	891360	HS	Rod, Connecting Assy (Incls: 2-Sleeves, 2-Washers, 2-Screws)	3
25	891361	CM	891361	CM	Crankshaft, Single End	1
30	891230	F	891230	F	Cover, Bearing, Blind	1
32	891234	NY	891234	NY	Cap, Filler w/Gasket	1
35	891226	SS	891226	SS	Rivet, (M2.9x6.5) (Not Shown)	6
36	891202	SS	891202	SS	Nameplate (Not Shown)	1
37	891233	—	891233	—	Gauge, Oil Bubble w/Gasket	1
40	890295	STL	890295	STL	Screw, HH (M16x50)	10
42	891237	SS	891237	SS	Washer, Flat (M8)	6
43	891225	SS	891225	SS	Screw, HSH (M8x15)	6
45	891243	SS	891243	SS	Screw, Grub (M10x20) (Not Shown)	4
48	891232	AL	891232	AL	Plug, HH Drain	1
50	891250	F	891250	F	Cover, Rear	1
52	891244	STL	891244	STL	Screw, Grub (M16)	2
53	891272	F	891272	F	Crankcase	1
55	891203	SS	891203	SS	Pin, Guide (M16x50) (Not Shown)	2
60	891201	—	891201	—	Cover, Rod Box	1
61	891224	SS	891224	SS	Screw, HSH (M10x15)	2
62	891282	STL	891282	STL	Pin, Roll (M6x25)	3
63	891280	F	891280	F	Crosshead	3
64	891281	STL	891281	STL	Pin, Crosshead	3
65	891261	SS	891261	SS	Rod, Plunger	3
66	891236	RBR	891236	RBR	Grommet, Cover	6
70	890275	PTFE	890275	PTFE	Seal, Oil - 70D	3
77	890216	FPM	890216	FPM	O-Ring, Carrier	3
80	891255	SS	891255	SS	Carrier, Oil Seal	3
88	890347	SS	890347	SS	Insert, Plunger	3
90	890415	CC	—	—	Plunger (M60.3x262) (See Tech Bulletin 115)	3
95	890368	SS	890368	SS	Plunger (M80x262) (See Tech Bulletin 115)	3
96	890336	PTFE	890336	PTFE	Stud, M20 x 200	3
97	890335	NBR	890335	NBR	Back-Up Ring - 70D	3
98	890348	SSD	890348	SSD	O-Ring - 70D	3
99	890312	SSD	890312	SSD	Gasket, Plunger Retainer Bolt	3
102	890372	NAB	890371	NAB	Retainer, Plunger	3
104	890203	NBR	890204	NBR	Adjuster, Packing	3
	890227	FPM	890314	FPM	O-Ring, Spacer - 70D	3
105	890580	SSD	890332	SSD	O-Ring, Spacer - 70D	3
106	890565	NBR	890566	NBR	Case, Seal [01/11]	3
	890561	FPM	890563	FPM	Seal, LPS	3
118	890389	SSD	890389	SSD	Seal, LPS	3
124	890352	SSD	890351	SSD	Plug, 1/16"NPT	3
127	890520	SFTK	890521	SFTK	Housing, Seal	3
129	890202	NBR	890202	NBR	V-Packing, Set	3
	890228	FPM	890228	FPM	O-Ring, Housing - 70D	3
130	890591	PTFE	890591	PTFE	O-Ring, Housing - 70D	3
145	890589	D	890589	D	Back-up-Ring, Housing	6
164	890259	SS	890259	SS	Ring, Sealing	3
166	890250	SSSS	890250	SSSS	Seat, QV	6
167	890319	SS	890319	SS	Valve, QV	6
171	890300	SS	890300	SS	Spring	6
172	890225	NBR	890225	NBR	Nut, QV	6
	890245	FPM	890245	FPM	O-Ring, Plug - 70D	6
174	890292	SSD	890292	SSD	O-Ring, Plug - 70D	6
175	890222	STTC	890222	STTC	Plug, Valve, Inlet	3
176	891294	SSD	891294	SSD	Plug, Valve, Discharge	72
185	892009	SSD	892009	SSD	Screw, HSH (M12x55)	3
188	891273	STTC	891273	STTC	Plug, Valve, Discharge	1
200	892016	POP	892016	POP	Head, Manifold	1
201	892018	RBR	892018	RBR	Screw, HSH (M24x100)	8
202	892019	SS	892019	SS	Barb, 1/4" NPT x 1/4" Barb	6
290	890999	—	890999	—	Hose, 9"x1/4" LOP	3
	890997	—	890997	—	Clamp, 1/4" Hose	6
295	891101	—	891101	—	Loctite® 641, 10ML (Not Shown)	1
296	890395	SSD	890396	SSD	Loctite® 243, 10ML (Not Shown)	1
297	891151	SSD	891151	SSD	Drive-end w/o Plungers (Includes: Items 2 thru 80, 349, 351, 352)	1
300	890036	NBR*	890037	NBR	Assembly, Plunger (Incls: 88, 90, 95, 96, 97, 98, 99) (See Tech Bulletin 115)	1
310	890018	NBR	890018	NBR	Assembly, Head (Incls: 164 thru 202)	1
	890019	NBR	890019	NBR	Kit, Seal (Incls: 70,77, 96, 97, 104,106,127)	1
349	891231	SS	891231	SS	Kit, Valve w/o Seat (Incls: 166,167,171,172,290)	2
					Kit, Valve (Incls: 164,166,167,171,172,290)	2
					Screw, HSH (M3x5)	2

EXPLODED VIEW

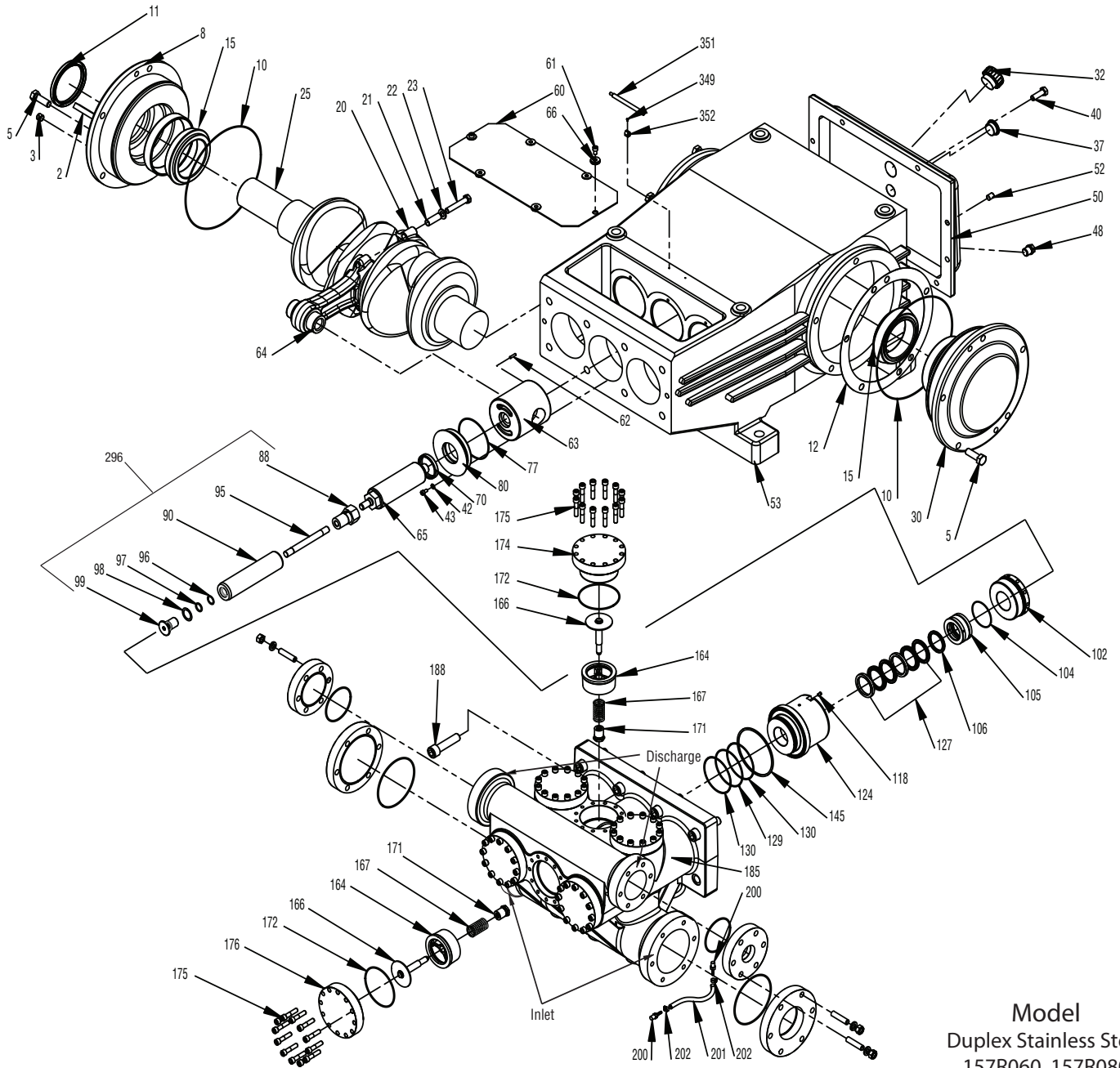

Model
Duplex Stainless Steel
157R060, 157R080
October 2012

ITEM	PART NUMBER		MATERIAL		DESCRIPTION	QTY
	157R060	MATL	157R080	MATL		
351	890990	SS	890990	SS	Tool, Packing Adjuster	1
352	890998	STZP	890998	STZP	Clip, Tool	2
390	719500	SS	719500	SS	C.A.T. (Inlet pressure stabilizer for RO and boosted inlet applications)	1
	890700	SS	890702	SS	Valve, Relief 2"	1
	701550	SS	—	—	Dampener, Pulsation (NBR Bladder)	1
393	892092	SS	892092	SS	Flange, Blank, Inlet (Specify Flange Type When Ordering)	1
394	892093	SS	892093	SS	Flange, Blank, Discharge ((Specify Flange Type When Ordering)	1
395	892096	SS	892096	SS	Flange, Discharge 2" NPT ((Specify Flange Type When Ordering)	1
396	892088	SS	892088	SS	Flange, Inlet 3" NPT (Specify Flange Type When Ordering)	1
—	6119	—	6119	—	Lubricant, Antiseize (1oz.)	1
—	6116	—	6116	—	Oil, Drum (16 gal.) ISO 100 Multiviscosity Hydraulic (Fill to specified crankcase capacity prior to start-up)	1-2

Loctite is a registered trademark of Henkel Corporation.

Bold print part numbers are unique to a particular pump model. *italics are optional items.* *Review material codes for individual items (SFTK generally may be used as alternate). MATERIAL CODES (Not Part of Part Number): AL=Aluminum CC=Ceramic CM=Chrome-Moly D=Acetal F=Cast Iron FPM=Fluorocarbon HS=High Strength NAB=Nickel Aluminum Bronze NBR=Medium Nitrile (Buna-N) NY=Nylon POP=Polypropylene PTFE=Pure Polytetrafluoroethylene RBR=RubberSFTK=Polytetrafluoroethylene/Aramid Fiber Blend SS=316SS SSSS=404SS SSD=Duplex Stainless STL=Steel STTC=Steel PTFE Coated STZP=Steel/Zinc Plated

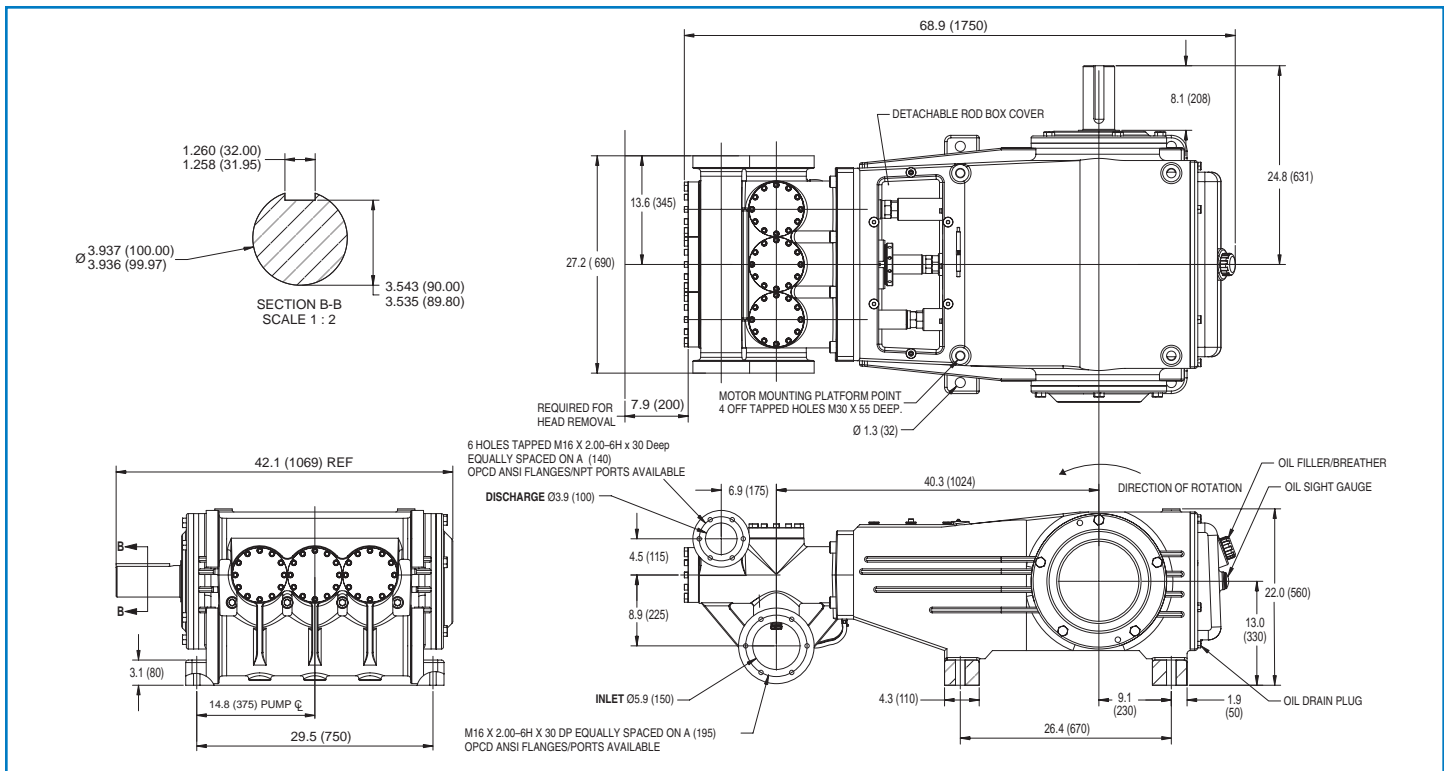

Models 157R060, 157R080

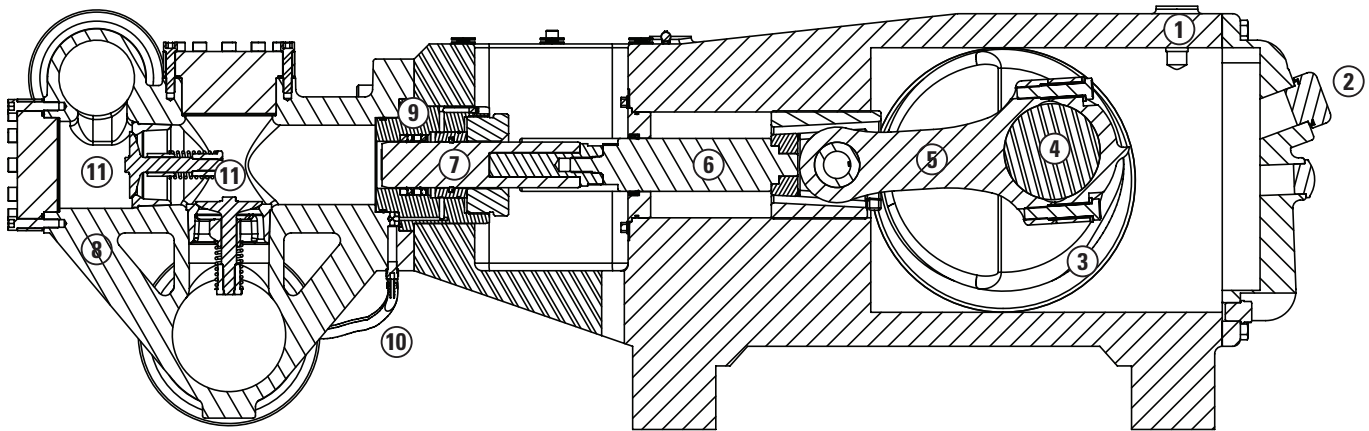

- 1 Spheroid graphite cast iron **crankcase** provides strength, vibration dampening and flame and spark resistance.
- 2 Convenient top rear access for **oil filler cap** permits easy access to oil level check.
- 3 Heavy-duty tapered roller **crankshaft bearings** for long life and secure alignment.
- 4 Chrome-moly, nitrided **crankshaft** provides unmatched strength and surface hardness for long life.
- 5 Matched oversized, **connecting rods** noted for superior tensile strength and bearing quality.
- 6 Special 316SS **plunger rods** with high-strength crossheads for longevity and corrosion resistance.
- 7 Special concentric, hardened, polished solid ceramic **plungers** offer resistance to corrosion and a true sealing surface for extended seal life. Plungers are conveniently serviceable from the top of the pump.
- 8 **Manifolds** are a high-strength, corrosion resistant Duplex stainless steel alloy for compatibility and long life.
- 9 High integrity **V-Packings** of PTFE/ Aramid Fiber Blend require no-adjustment and provide long life with harsh liquids.
- 10 High pressure V-Packing **bleed (weep) hose** captures leaks as V-Packings begin to wear preventing external leaks.
- 11 316 stainless steel **seats, valves and springs** for corrosion resistance and extended life.



CAT PUMPS

1681 - 94TH LANE N.E. MINNEAPOLIS, MN 55449-4324
 PHONE (763) 780-5440 — FAX (763) 780-2958
 e-mail: techsupport@catpumps.com
 www.catpumps.com