

FLANGE-MOUNT CENTRIFUGAL PUMPS

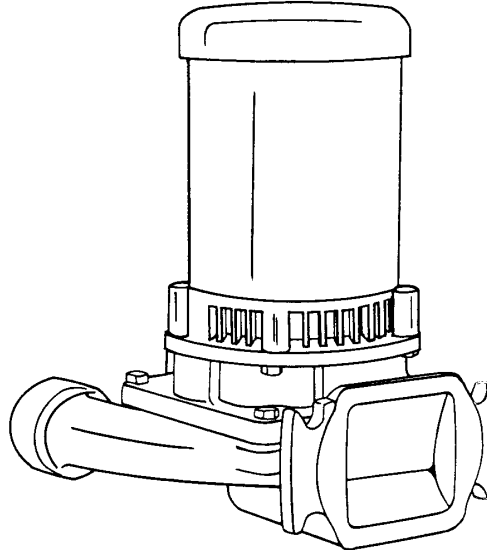

Ideal for OEM applications requiring a pump with inlet flange-mounted to tank or other vessel.

Flanged and gasketed inlet will adapt to any flat mounting surface.

Pump may be installed vertically or horizontally.

May be used as replacement pump on Burks Series GV Condensate Return Systems.

FEATURES

- 1/3 thru 3 hp - seven stock sizes.
- Capacities to 80 GPM (5 L.P.S.) - Heads to 130 feet (39.6M).
- Efficient hydraulic design.
- Enclosed bronze impeller threaded onto stainless steel motor shaft.
- Impeller balanced for smooth, quiet operation.
- Replaceable bronze casing wear ring.
- Back pull-out design allows servicing without disturbing piping. Pump casing stays in place.
- Mechanical shaft seal is self-adjusting - for temperatures to 225°F (107°C) and pressures to 150 PSI (1034kpa).
- Special seals available for higher temperatures and fluids other than water.
- Tappings provided for venting and flushing seal area.
- Bronze fitted, close grain cast iron construction is standard. All Iron available.
- ODP motors are standard. Drip cover provided for vertical installation.
- EVERY pump is factory tested.

SECTION	2E
PAGE	2
ISSUED	2/03
REPLACES	12/01



420 Third Street
Piqua, Ohio 45356-0603
Phone: (937) 778-8947 Fax: (937) 773-7157

FEATURES

MAXIMUM OPERATING CONDITIONS	
TEMPERATURE (For Standard Buna-N Seal)	225°F (107°C)
INLET PRESSURE	100 PSI (690 kpa)
CASING WORKING PRESSURE	200 PSI (1379kpa)

Overload Protection: All single phase ODP and Totally Enclosed motors have built-in overload protection. All three phase motors and all explosion proof motors must be installed with a magnetic starter which provides full 3-leg protection. Failure to use correct starter and overloads will void motor warranty.

MOTORS

Standard pump motors have open drip proof construction and are rated with jet pump service factors for continuous duty operation. Open Drip Proof motors are 56 frame size with NEMA standard mounting flange, one piece threaded stainless steel shaft and ball/ball bearing construction.

MOTOR INFORMATION

60 Hz - 3500 RPM - ODP

50 Hz - 2900 RPM - ODP

Single Phase: Thru 2Hp - 115/230 Volt.

3Hp is 230Volt only

Three Phase: 230/460 Volt.

Voltages may differ from some suppliers. Consult factory.

MATERIALS OF CONSTRUCTION

PART	ALL IRON	BRONZE FITTED
Adapter	Cast Iron	Cast Iron
Casing	Cast Iron	Cast Iron
Shaft	#303 Stainless	#303 Stainless
Impeller	Cast Iron	Bronze
Wear Ring	Steel	Bronze
Shaft Seal	Carbon-Ceramic S. Steel-Buna-N	Carbon-Ceramic S. Steel-Buna-N

Series GV6-11/4 pumps are not available with 3 HP Single Phase TEFC motors or 3 HP Explosion Proof motors - single phase.

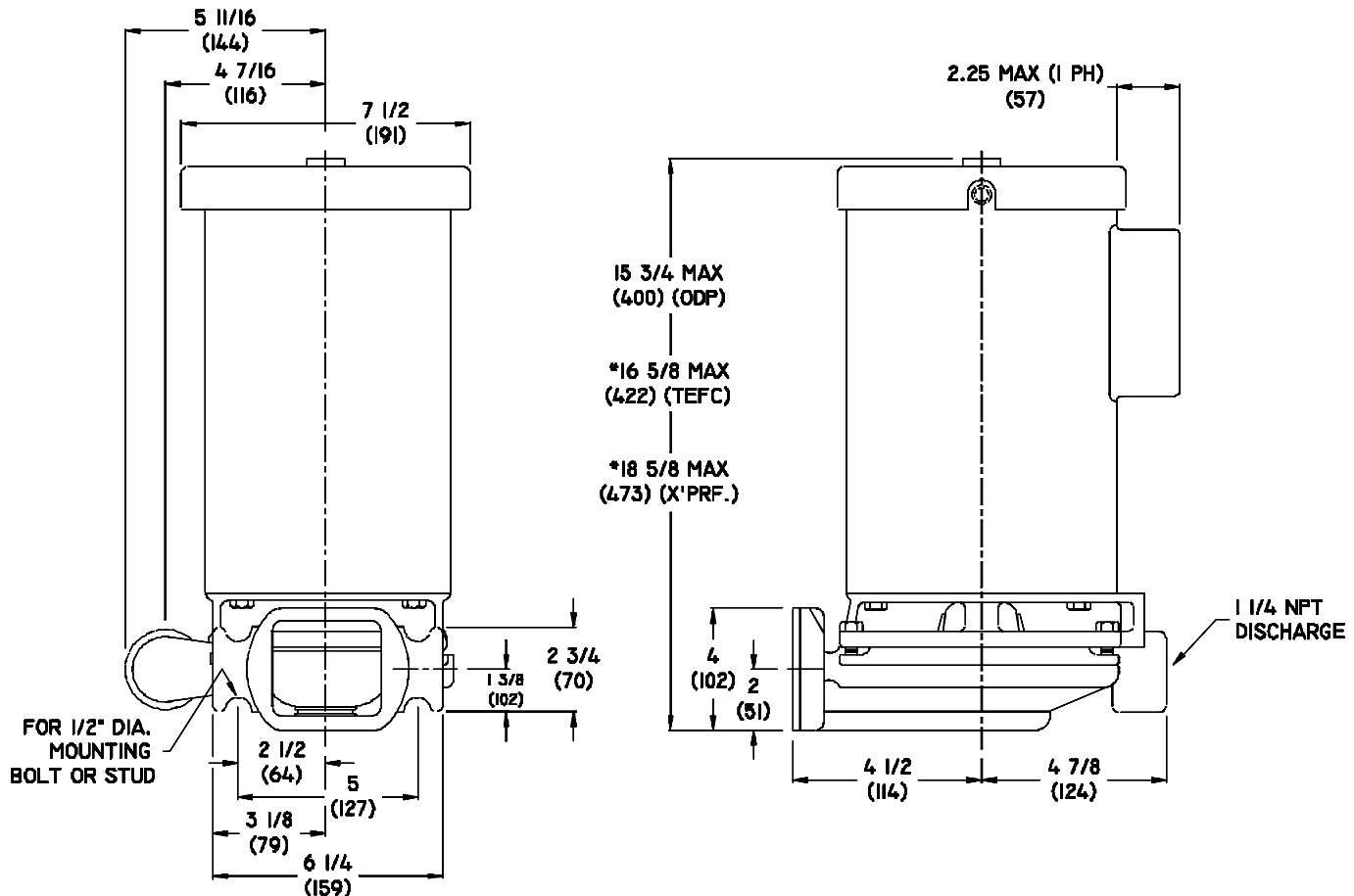

PUMPS & SYSTEMS

A Crane Co. Company

END SUCTION CENTRIFUGAL PUMPS

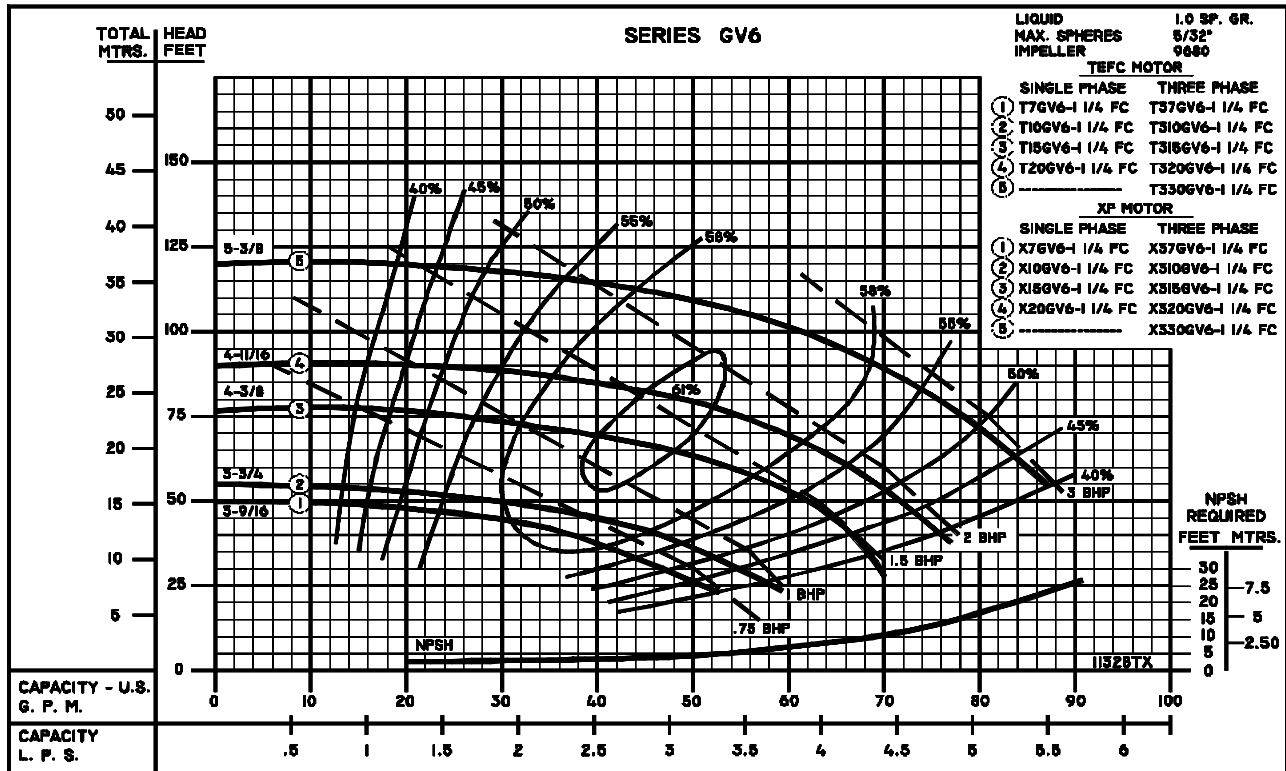
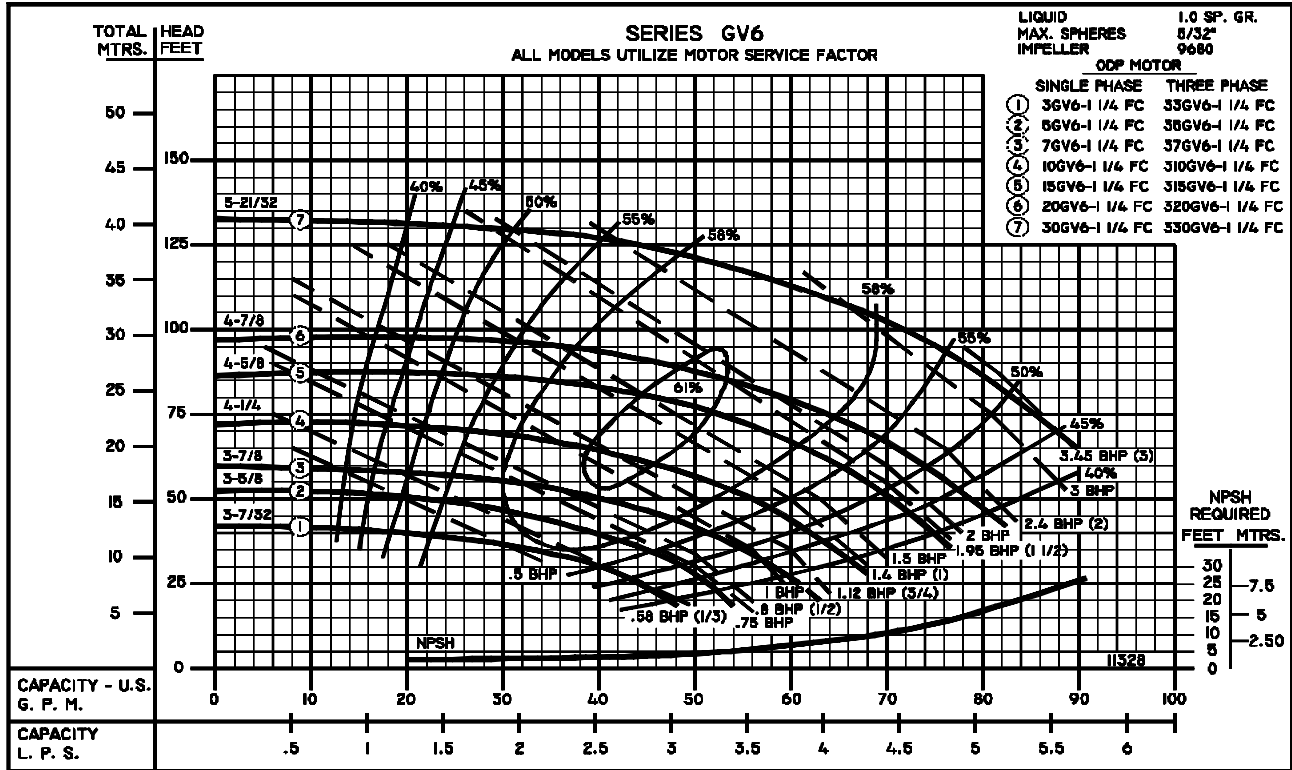

SECTION	2E
PAGE	4
ISSUED	2/03
REPLACES	12/01

50HZ PERFORMANCE CURVE



420 Third Street
Piqua, Ohio 45356-0603
Phone: (937) 778-8947 Fax: (937) 773-7157

END SUCTION CENTRIFUGAL PUMPS

2900
RPM

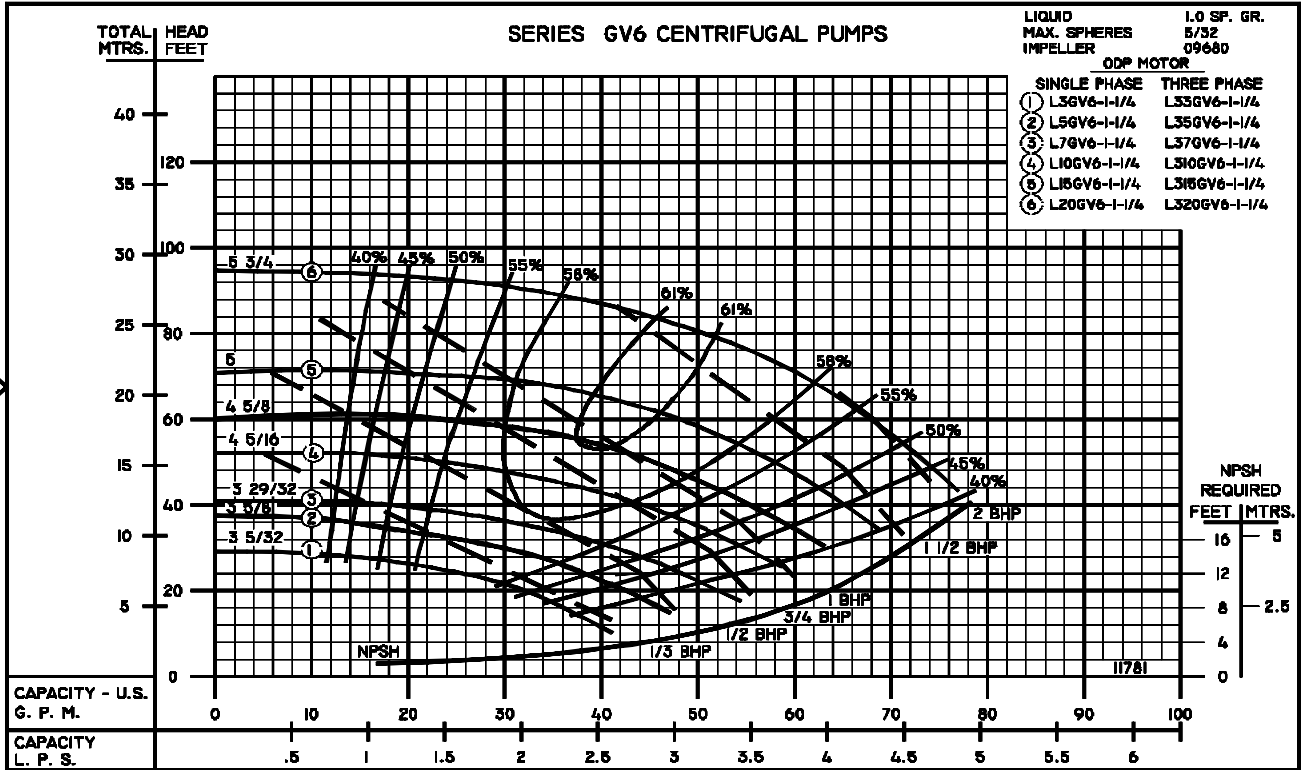

2900
RPM

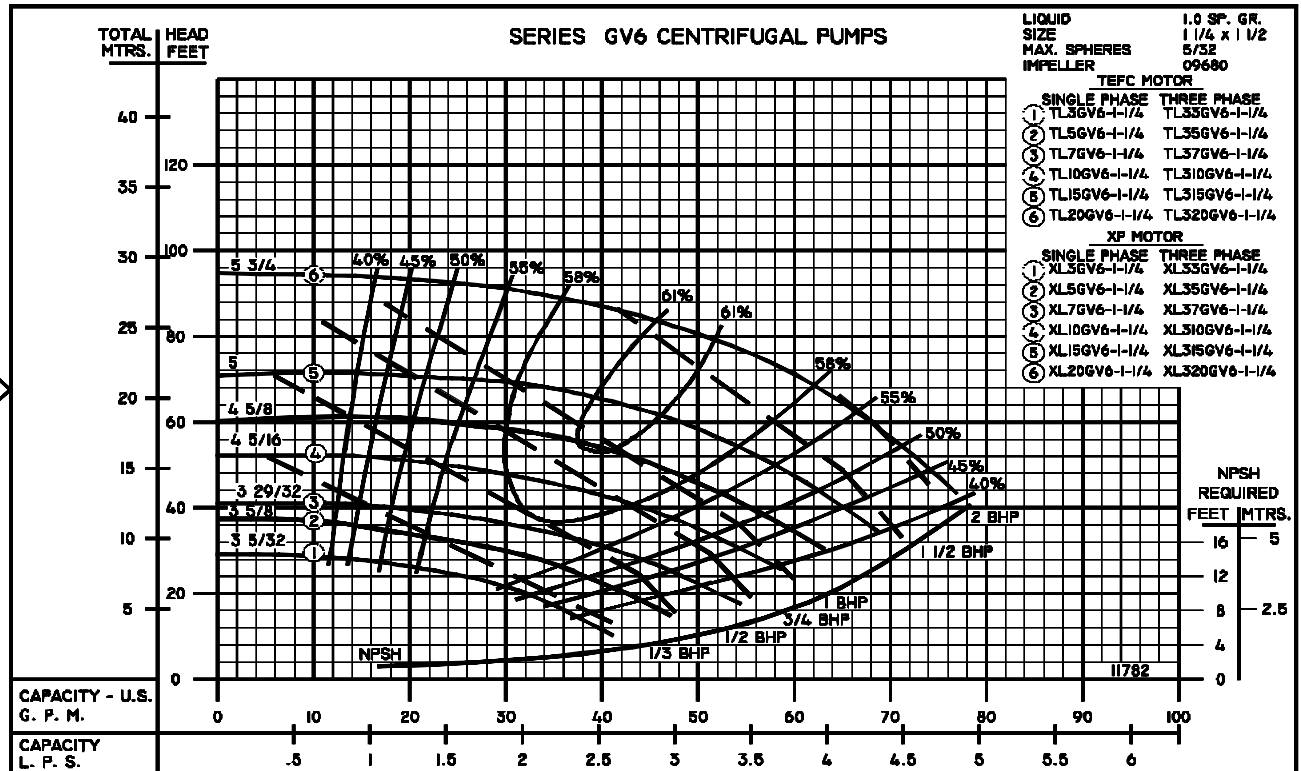

PUMPS & SYSTEMS

A Crane Co. Company