

Base Mounted Centrifugal Pumps

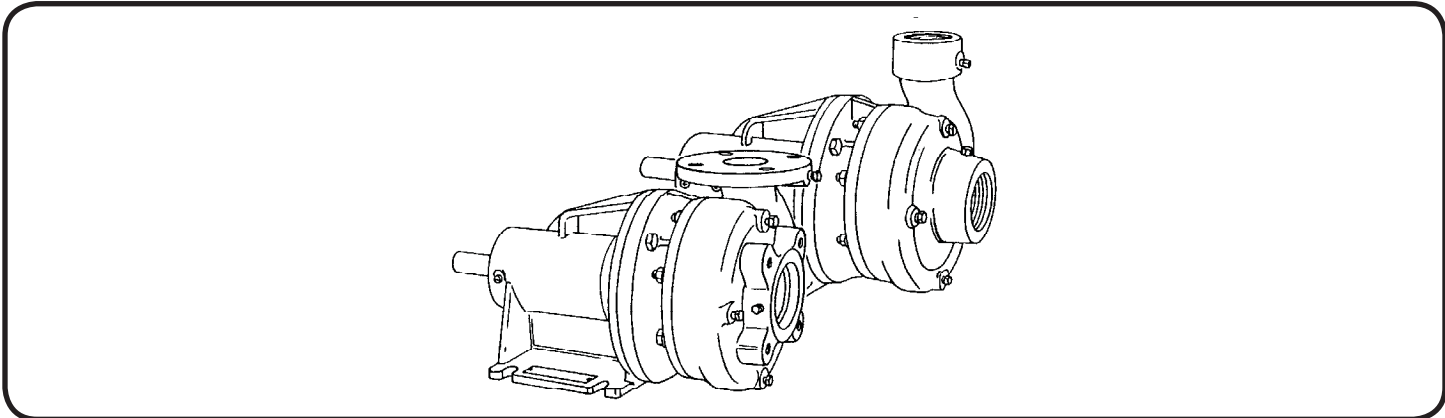

1750 RPM - 60Hz.
CAPACITIES TO 1100 GPM (69.4 LPS)
HEADS TO 95 FEET (29 M)

(*) FOR CAPACITIES ABOVE 500 GPM
SEE GNB9-4F CURVE.

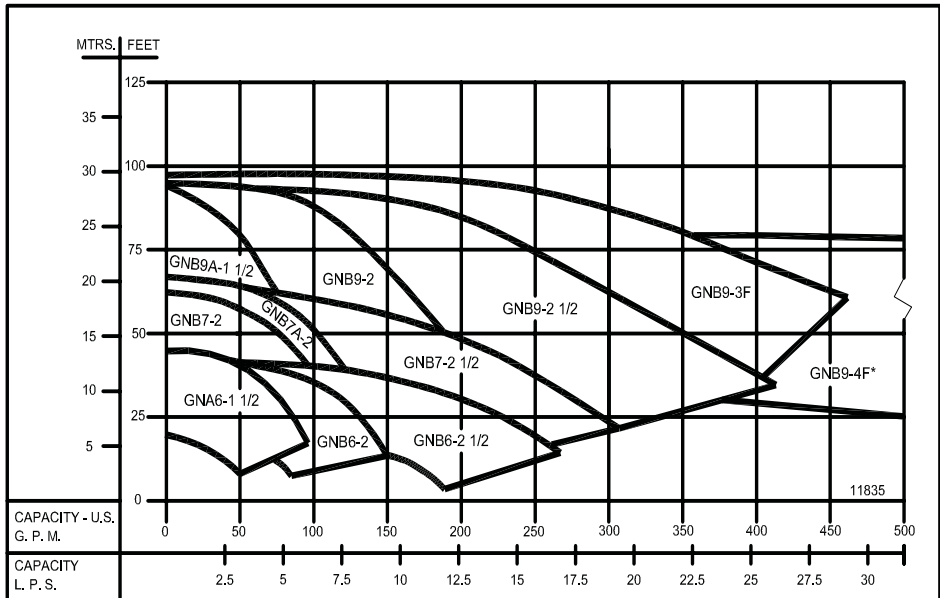

1450 RPM - 50Hz.
CAPACITIES TO 340 GPM (21.5 LPS)
HEADS TO 62 FEET (19 M)

Individual performance curve should be
checked for final selection.

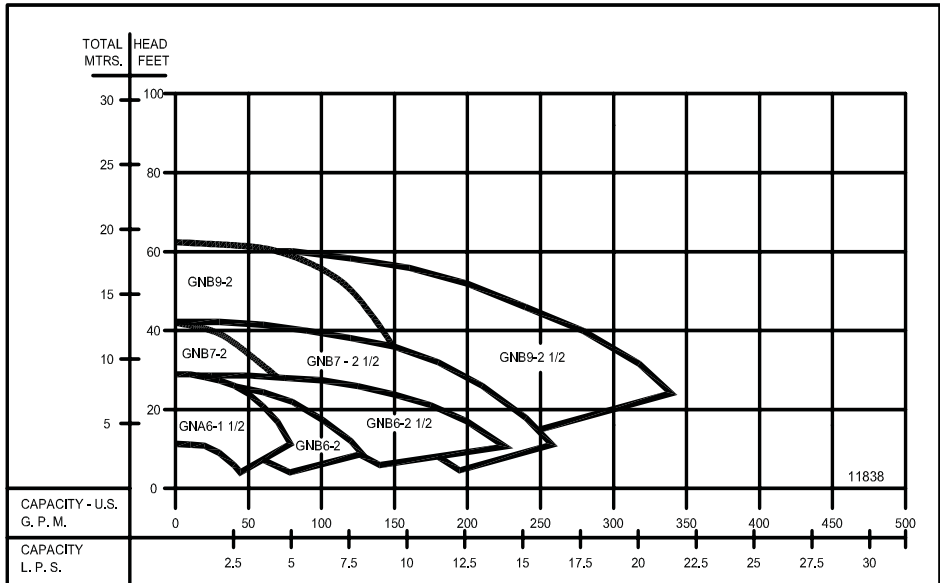

Base Mounted Centrifugal Pumps

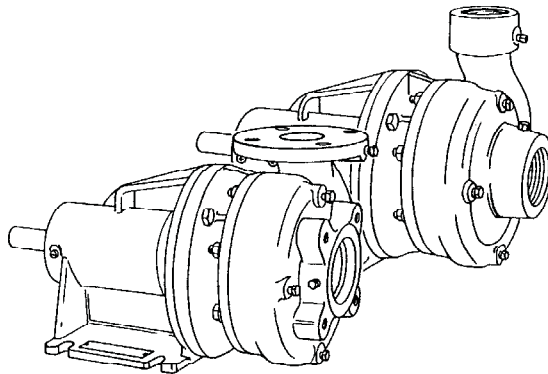

3500 RPM - 60Hz.
CAPACITIES TO 960 GPM (60.6 LPS)
HEADS TO 380 FEET (116 M)

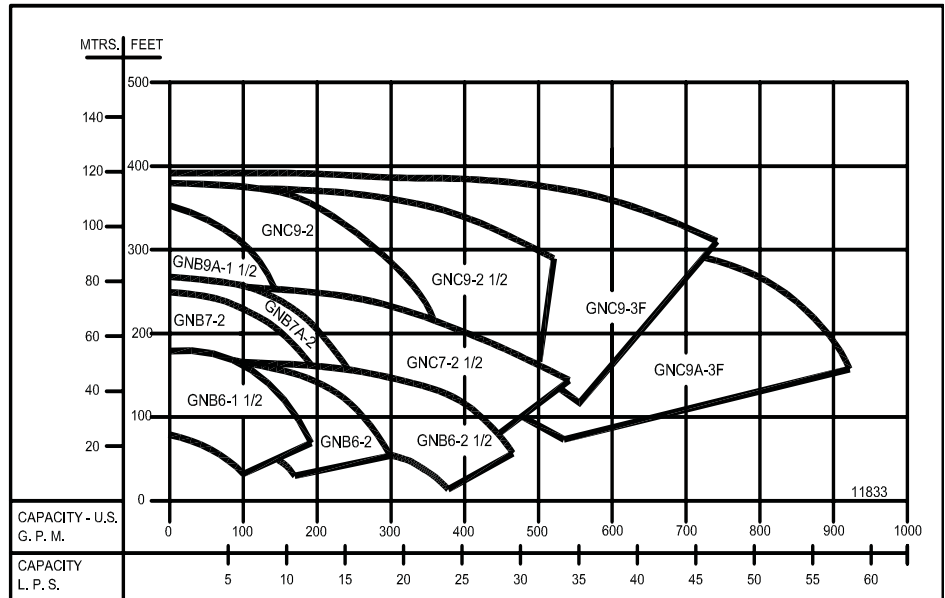

2900 RPM - 50Hz.
CAPACITIES TO 640 GPM (40.4 LPS)
HEADS TO 270 FEET (82.3 M)

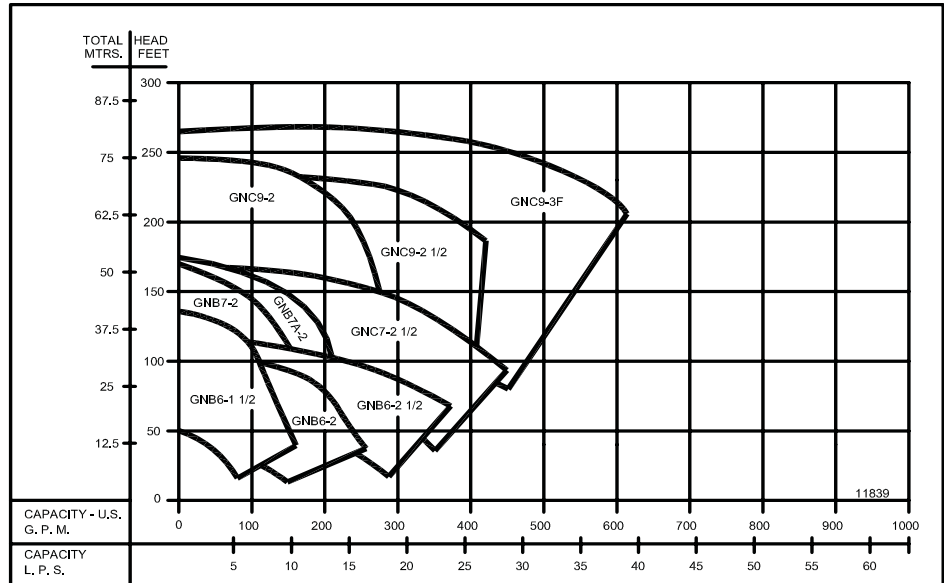

Individual performance curve should be checked for final selection.

Base Mounted Centrifugal Pumps

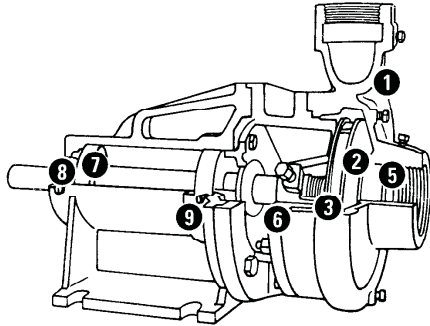

1. RADIAL SPLIT CASING DESIGN

Casing is close grain iron of 30,000 p.s.i. minimum tensile strength. Back pull-out design eliminates the need to disturb piping should the pump ever require service - the casing stays in the line. Centerline discharge. Stud mounted casing assures positive alignment and allows rotation of discharge to eight different positions. Openings are provided for test gauges, for venting and for draining the pump.

2. ENCLOSED BRONZE IMPELLER

Enclosed bronze impeller is of latest hydraulic design for maximum efficiency. It is balanced for vibration free operation. Precision fit to shaft and double-locked with key and cap screw.

3. MECHANICAL SHAFT SEAL

Mechanical Shaft Seal is self-adjusting for temperatures up to 225°F (107°C) and pressures to 150 psi (1034kpa). Has ceramic seat and carbon seal faces for long trouble-free service. Special seals are available for higher temperatures and fluids other than water. Tapped opening is provided in the seal chamber for flushing seal faces.

MAXIMUM OPERATING CONDITIONS		
Pumping Speed	3500 & 2900 RPM	1750 & 1450 RPM
Horsepower with "A" Power Frame	N/A	1 HP
Horsepower with "B" Power Frame	20 HP	15 HP
Horsepower with "C" Power Frame	75 HP	N/A
Pumping Temperature*	225°F (107°C)	
Inlet Pressure	100 PSI (690kpa)	
Case Working Pressure	200 PSI (1379kpa)	

* FOR STANDARD BUNA-N SEAL

MATERIALS OF CONSTRUCTION			
Part	Brone Fitted	All Bronze	All Iron
Adapter	Cast Iron	Bronze	Cast Iron
Casing	Cast Iron	Bronze	Cast Iron
Casing Wear Ring	Bronze	Bronze	Steel
Shaft	Steel	Steel	Steel
Shaft Sleeve	Bronze	Bronze	#316 Stainless
Impeller	Bronze	Bronze	Cast Iron
Shaft Seal	Carbon-Ceramic SS - Buna-N	Carbon-Ceramic SS - Buna-N	Carbon-Ceramic SS - Buna-N

SUCTION & DISCHARGE SIZES		
* SERIES	SUCTION (in)	DISCHARGE (in)
GNA6-1-1/2	2	1-1/2
GNB6-1-1/2	2	1-1/2
GNB6-2 & 2F	2-1/2	2
GNB6-2-1/2 & 2-1/2F	3	2-1/2
GNB7-2 & 2F	2-1/2	2
GNB7A-2 & 2F	2-1/2	2
GNB7-2-1/2 & 2-1/2F	3	2-1/2
GNC7-2-1/2 & 2-1/2F	3	2-1/2
GNB9A-1-1/2	2	1-1/2
GNB9-2 & 2F	2-1/2	2
GNC9-2 & 2F	2-1/2	2
GNB9-2-1/2 & 2-1/2F	3	2-1/2
GNC9-2-1/2 & 2-1/2F	3	2-1/2
GNB9-3F	4	3
GNC9-3F	4	3

*F Suffix Denotes ANSI 125# Flat Face Flanges

4. COUPLING GUARD (NOT SHOWN)

Furnished on all complete Base-Mounted units manufactured by Burks Pumps. Not furnished with purchase of pump only, but required.

5. REPLACEABLE CASING WEAR RING

Prevents wear on casing and is easy to replace.

6. GASKETED BRONZE SLEEVE

Gasketed Bronze Sleeve on GNB and GNC power frames protects the shaft against wear and corrosion. Shaft on GNA power frame in #316 Stainless Steel.

7. BEARINGS

Grease lubricated ball bearings provide two years minimum service at maximum load. Average bearing life is five times minimum. Wide bearing spacing provides solid shaft support.

8. OIL SEALS

Protect both bearings.

9. CONVENIENT RELUBRICATION

Tapped and plugged openings are conveniently located for easy relubrication of power frame.

10. FACTORY TESTED

After careful assembly and inspection, EVERY pump is factory tested and will meet Hydraulic Institute standards.

FOR TEMPERATURES TO 500°F (260°C).

All models, with the exception of the GNA7-21/2 and all GN9 series pumps are available in a Jacketed Seal Cavity design for pumping hot oil, hot water and heat transfer fluids in common use in high temperature heating or cooling applications. This feature greatly extends seal life in high temperature applications. To order, add suffix "MJ" to pump catalog number for temperatures below 400°F (204°C) and add suffix "MJK" to pump catalog number for temperatures over 400°F (204°C). Example: GNA5-11/2MJ. See Section on High Temperature Pumps for more information.

Series: GNA

Dimensions

Pump Only and Pump, Motor & Coupling - Base Mounted



Base Mounted Centrifugal Pumps

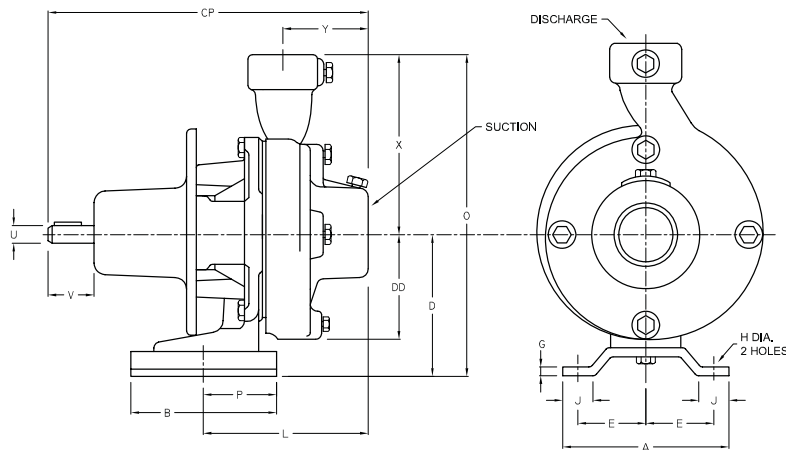

DIMENSIONS IN INCHES

MODEL	DISC.	SUCT.	A	B	CP	D	DD	E	G	H	J	L	O	P	U	V	X	Y
GNA6-1½	1½	2	5	4	10 ⁵ / ₈	5 ⁵ / ₁₆	4 ¹ / ₈	1 ¹⁵ / ₁₆	¼	9 ¹ / ₁₆	1 ¹ / ₈	5 ⁷ / ₈	12 ⁹ / ₁₆	1 ³ / ₄	5 ⁵ / ₈	1 ¹¹ / ₁₆	7 ¹ / ₄	2 ³ / ₄

DIMENSIONS IN MILLIMETERS

MODEL	DISC. (in)	SUCT. (in)	A	B	CP	D	DD	E	G	H	J	L	O	P	U	V	X	Y
GNA6-1½	1½	2	127	102	270	135	105	49	6.3	14	29	149	319	44	16	43	184	70

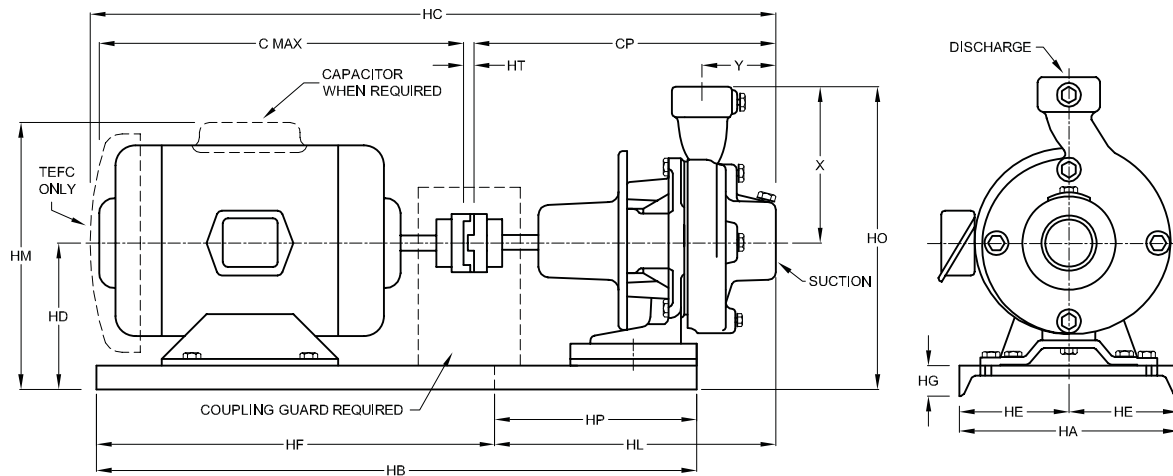

DIMENSIONS IN INCHES

MODEL	MOTOR FRAME	Disc.	Suct.	C*	CP	HA	HB	HC*	HD	HE	HF	HG	HH	HL	HM	HO	HP	HT	X	Y
GNA6-1½	56	1½	2	12 ⁵ / ₁₆	10 ⁵ / ₈	8	20 ¹ / ₄	23 ³ / ₁₆	7 ¹³ / ₁₆	3	14 ⁷ / ₈	2 ¹ / ₂	1 ¹ / ₁₆	8 ⁵ / ₈	13 ¹ / ₈	15 ¹ / ₁₆	4 ³ / ₈	¼	7 ¹ / ₄	2 ³ / ₄
	143T			13 ⁹ / ₁₆	10 ⁵ / ₈	8	20 ¹ / ₄	24 ⁷ / ₁₆	7 ¹³ / ₁₆	3	14 ⁷ / ₈	2 ¹ / ₂	1 ¹ / ₁₆	8 ⁵ / ₈	9 ⁷ / ₈	15 ¹ / ₁₆	4 ³ / ₈	¼	7 ¹ / ₄	2 ³ / ₄
	145T			13 ⁹ / ₁₆	10 ⁵ / ₈	8	20 ¹ / ₄	24 ⁷ / ₁₆	7 ¹³ / ₁₆	3	14 ⁷ / ₈	2 ¹ / ₂	1 ¹ / ₁₆	8 ⁵ / ₈	9 ⁷ / ₈	15 ¹ / ₁₆	4 ³ / ₈	¼	7 ¹ / ₄	2 ³ / ₄

DIMENSIONS IN MILLIMETERS

MODEL	MOTOR FRAME	Disc.	Suct.	C*	CP	HA	HB	HC*	HD	HE	HF	HG	HH	HL	HM	HO	HP	HT	X	Y
GNA6-1½	56	1½	2	313	270	203	514	589	198	76	378	64	17	219	333	383	111	6.3	184	70
	143T			344	270	203	514	621	198	76	378	64	17	219	251	383	111	6.3	184	70
	145T			344	270	203	514	621	198	76	378	64	17	219	251	383	111	6.3	184	70

(*) Maximum - Varies with Enclosure, HP and Motor Manufacturer.

SECTION 3B
PAGE 4
DATE 1/06



PUMPS & SYSTEMS

A Crane Co. Company

USA: (937) 778-8947 • Canada: (905) 457-6223 • International: (937) 615-3598

Base Mounted Centrifugal Pumps

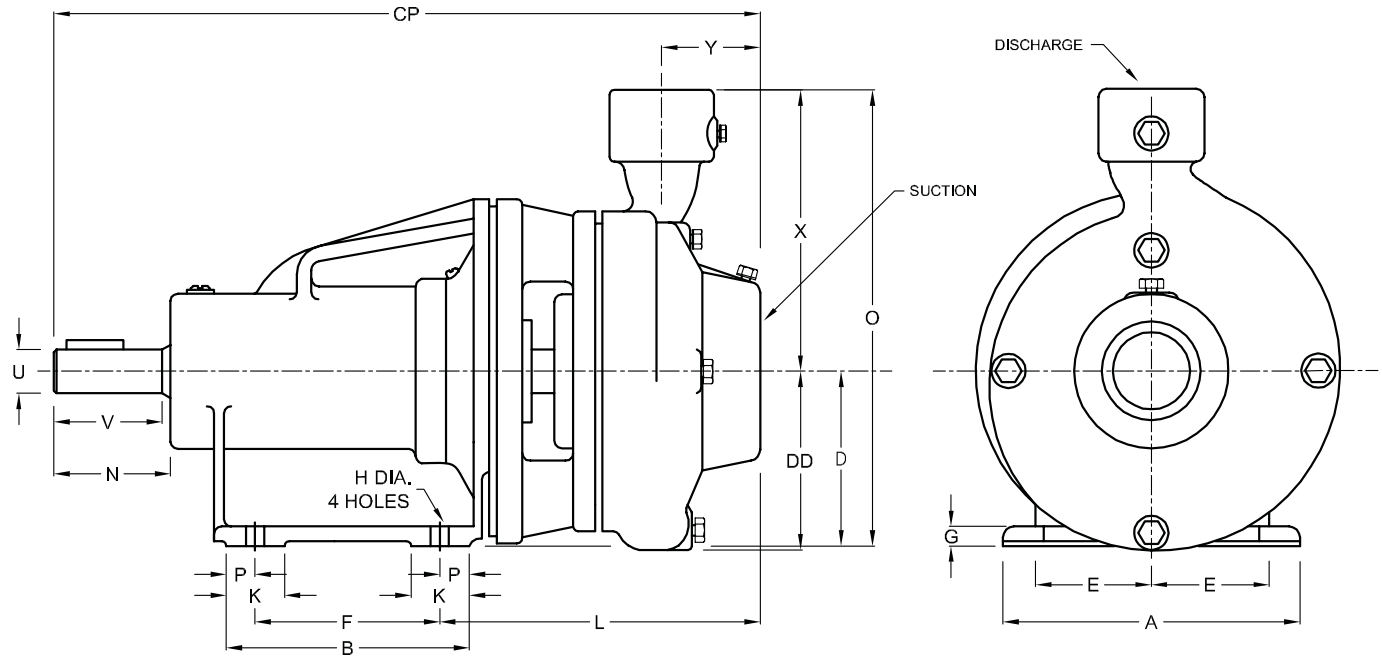

DIMENSIONS IN INCHES

MODEL	DISC.	SUCT.	A	B	CP	D	DD	E	F	G	H	K	L	N	O	P	U	V	X	Y
GNB6-1½	1½	2	8	6½	18¾	4½	4⅛	3⅜	5	½	⅝	1½	8⅜	2⅞	11¼	¾	1⅞	2⅛	7¼	2¾
GNB6-2	2	2½	8	6½	18½	4½	4⅞	3⅜	5	½	⅝	1½	8⅝	2⅞	12	¾	1⅞	2⅛	7¼	2⅜
GNB6-2½	2½	3	8	6½	19⅞	4½	4⅞	3⅜	5	½	⅝	1½	9	2⅞	12¾	¾	1⅞	2⅛	8¼	3⅜
GNB7-2 GNB7A-2	2	2½	8	6½	19¾	4½	5	3⅜	5	½	⅝	1½	9⅜	2⅞	12¾	¾	1⅞	2⅛	8¼	3¼
GNB7-2½	2½	3	8	6½	19¾	4½	5½	3⅜	5	½	⅝	1½	9⅞	2⅞	13¾	¾	1⅞	2⅛	9¼	3½
GNB9A-1½	1½	2	8	6½	18⅛	4½	5⅜	3⅜	5	½	⅝	1½	8½	2⅞	13½	¾	1⅞	2⅛	9	3⅜
GNB9-2	2	2½	8	6½	19⅜	4½	5⅜	3⅜	5	½	⅝	1½	9⅞	2⅞	14⅞	¾	1⅞	2⅛	9⅞	4
GNB9-2½	2½	3	8	6½	19⅞	4½	6⅞	3⅜	5	½	⅝	1½	9¼	2⅞	15	¾	1⅞	2⅛	10½	3½
GNC7-2½	2½	3	8	6¾	22	7	5½	3⅜	5	½	⅝	1¾	10½	4	14¾	⅞	1⅞	3¼	9¼	3½
GNC9-2	2	2½	8	6¾	23	7	5⅜	3⅜	5	½	⅝	1¾	11¼	4	15⅞	⅞	1⅞	3¼	9⅞	4
GNC9-2½	2½	3	8	6¾	22½	7	6⅞	3⅜	5	½	⅝	1¾	10¾	4	17½	⅞	1⅞	3¼	10½	3½

DIMENSIONS IN MILLIMETERS

MODEL	DISC. (in)	SUCT. (in)	A	B	CP	D	DD	E	F	G	H	K	L	N	O	P	U	V	X	Y
GNB6-1½	1½	2	203	165	467	114	105	90	127	13	16	38	208	73	298	19	28	68	184	70
GNB6-2	2	2½	203	165	470	114	113	90	127	13	16	38	211	73	305	19	28	68	191	71
GNB6-2½	2½	3	203	165	487	114	124	90	127	13	16	38	229	73	324	19	28	68	210	84
GNB7-2 GNB7A-2	2	2½	203	165	492	114	127	90	127	13	16	38	233	73	324	19	28	68	210	95
GNB7-2½	2½	3	203	165	492	114	140	90	127	13	16	38	232	73	349	19	28	68	235	89
GNB9A-1½	1½	2	203	165	475	114	148	90	127	13	16	38	216	73	343	19	28	68	228	78
GNB9-2	2	2½	203	165	503	114	151	90	127	13	16	38	244	73	359	19	28	68	244	102
GNB9-2½	2½	3	203	165	494	114	154	90	127	13	16	38	235	73	381	19	28	68	267	89
GNC7-2½	2½	3	203	171	559	178	140	90	127	13	16	44	267	102	375	22	35	95	235	89
GNC9-2	2	2½	203	171	584	178	151	90	127	13	16	44	286	102	397	22	35	95	244	102
GNC9-2½	2½	3	203	171	572	178	154	90	127	13	16	44	273	102	445	22	35	95	267	89

Base Mounted Centrifugal Pumps

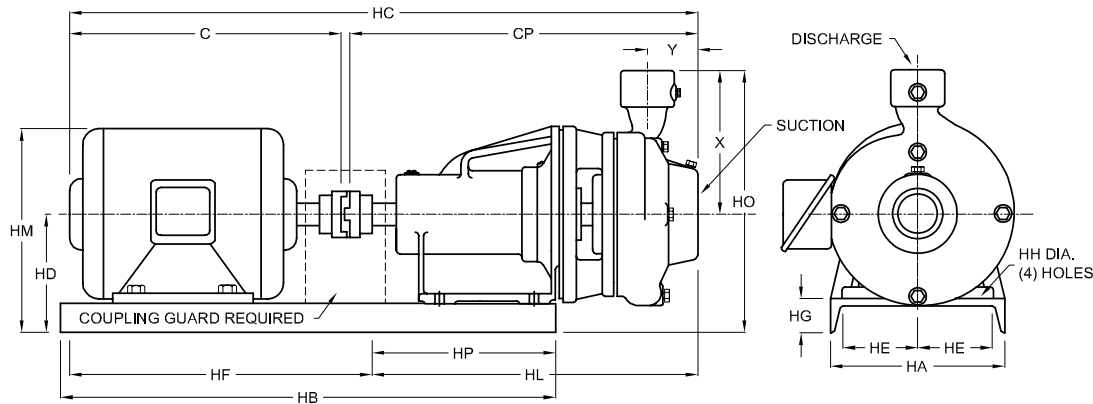

DIMENSIONS IN INCHES																				
MODEL	MOTOR FRAME	Disc.	Suct.	C*	CP	HA	HB	HC*	HD	HE	HF	HG	HH	HL	HM	HO	HP	HT	X	Y
GNB6-1½	56	1½	2	12½/16	18%	10	25¼	30½/16	7	4	15½	2½	1¼/16	15%	11%	14¼	8¼	¼	7¼	2¾
	143T/145T	1½	2	13³/16	18%	10	25¼	32³/16	7	4	15½	2½	1¼/16	15%	10%	14¼	8¼	¼	7¼	2¾
	182T/184T	1½	2	16¹¹/16	18%	10	28¼	35³/16	7	4	18½	2½	1¼/16	15%	11½/16	14¼	8¼	¼	7¼	2¾
	213T/215T	1½	2	20½	18%	12	32	39%	7¾	5	30	2½	1¼/16	8%	13½	15	1	¼	7¼	2¾
GNB6-2	56	2	2½	12³/16	18½	10	25¼	39%/16	7	4	15½	2½	1¼/16	16	11%	14½	8¼	¼	7½	2³/16
	143T/145T	2	2½	13³/16	18½	10	25¼	32³/16	7	4	15½	2½	1¼/16	16	10%	14½	8¼	¼	7½	2³/16
	182T/184T	2	2½	16¹¹/16	18½	10	28¼	35¾/16	7	4	18½	2½	1¼/16	16	11½/16	14½	8¼	¼	7½	2³/16
	213T/215T	2	2½	20½	18½	12	32	39¼	7¾	5	30	2½	1¼/16	8¼	12³/16	15¼	1	¼	7½	2³/16
GNB6-2½	56	2½	3	12³/16	19¾	10	25¼	32¼	7	4	15½	2½	1¼/16	16¹¹/16	11%	15¼	8¼	¼	8¼	3½/16
	143T/145T	2½	3	13³/16	19¾	10	25¼	33	7	4	15½	2½	1¼/16	16¹¹/16	10%	15¼	8¼	¼	8¼	3½/16
	182T/184T	2½	3	16¹¹/16	19¾	10	28¼	36%	7	4	18½	2½	1¼/16	16¹¹/16	11½/16	15¼	8¼	¼	8¼	3½/16
	213T/215T	2½	3	20½	19¾	12	32	39½/16	7¾	5	30	2½	1¼/16	8¹⁵/16	12³/16	16	1	¼	8¼	3½/16
GNB7-2	56	2	2½	12³/16	19%	10	25¼	32³/16	7	4	15½	2½	1¼/16	16%	11%	15¼	8¼	¼	8¼	3¾
	143T/145T	2	2½	13³/16	19%	10	25¼	33³/16	7	4	15½	2½	1¼/16	16%	10%	15¼	8¼	¼	8¼	3¾
	182T/184T	2	2½	16¹¹/16	19%	10	28¼	36³/16	7	4	18½	2½	1¼/16	16%	11½/16	15¼	8¼	¼	8¼	3¾
	213T/215T	2	2½	20½	19%	12	32	40%	7¾	5	30	2½	1¼/16	9%	12³/16	16	1	¼	8¼	3¾
GNB7-2½	143T/145T	2½	3	13³/16	19%	10	25¼	33³/16	7	4	18½	2½	1¼/16	16%	10%	14¾	8¼	¼	9¼	3½
	182T/184T	2½	3	16¹¹/16	19%	10	28¼	36³/16	7	4	18½	2½	1¼/16	16%	11½/16	14¾	8¼	¼	9¼	3½
GNB9A-1½	56	1½	2	12³/16	18¹¹/16	10	25¼	31¾	7	4	15½	2½	1¼/16	16³/16	11%	16	8¼	¼	9	3½/16
	143T/145T	1½	2	13³/16	18¹¹/16	10	25¼	32½	7	4	15½	2½	1¼/16	16³/16	10%	16	8¼	¼	9	3½/16
	182T/184T	1½	2	16¹¹/16	18¹¹/16	10	28¼	35%	7	4	18½	2½	1¼/16	16³/16	11½/16	16	8¼	¼	9	3½/16
	213T/215T	1½	2	20½	18¹¹/16	12	32	39¾/16	7¾	5	30	2½	1¼/16	8¾	12³/16	16¾	1	¼	9	3½/16
GNB9-2	143T/145T	2	2½	13³/16	19%	10	25¼	33³/16	7	4	15½	2½	1¼/16	17½/16	10%	15%	8¼	¼	9%	4
	182T/184T	2	2½	16¹¹/16	19%	10	28¼	36¹¹/16	7	4	18½	2½	1¼/16	17½/16	11½/16	15%	8¼	¼	9%	4
GNB9-2½	143T/145T	2½	3	13³/16	19%	10	25¼	33³/16	7	4	15½	2½	1¼/16	16¹⁵/16	10%	17½	8¼	¼	10½	3½
	182T/184T	2½	3	16¹¹/16	19%	10	28¼	36³/16	7	4	18½	2½	1¼/16	16¹⁵/16	11½/16	17½	8¼	¼	10½	3½
	213T/215T	2½	3	20½	19%	12	32	40%	7¾	5	30	2½	1¼/16	9%	12³/16	18¼	1	¼	10½	3½
GNC7-2½	213T/215T	2½	3	20½	22½	12	33¾	43¼	9½	5	31¼	2½	1¼/16	10%	14½	17¼	1	¼	9¼	3½
	254T/256T	2½	3	24¾	22½	14	38	47%	9½	6	36	2½	1¼/16	10%	15%	17¼	1	¼	9¼	3½
	284TS/286TS	2½	3	26³/16	22½	14	39½	49%/16	9½	6	37½	2½	1¼/16	10%	16%	17¼	1	¼	9¼	3½
GNC9-2	213T/215T	2	2½	20½	23	12	33¾	43¾	9½	5	31¼	2½	1¼/16	11%	14½	18%	1	¼	9%	4
	254T/256T	2	2½	24¾	23	14	38	48%	9½	6	36	2½	1¼/16	11%	15%	18%	1	¼	9%	4
	284TS/286TS	2	2½	26³/16	23	14	39½	49%/16	9½	6	37½	2½	1¼/16	11%	16%	18%	1	¼	9%	4
	324TS/326TS	2	2½	28¾	23	16	42	52	10½	7	40	2½	1¼/16	11%	18%	19%	1	¼	9%	4
GNC9-2½	254T/256T	2½	3	24¾	22½	14	38	47%	9½	6	36	2½	1¼/16	10%	15%	20	1	¼	10½	3½
	284TS/286TS	2½	3	26³/16	22½	14	39½	49%/16	9½	6	37½	2½	1¼/16	10%	16%	20	1	¼	10½	3½
	324TS/326TS	2½	3	28¾	22½	16	42	51½	10½	7	40	2½	1¼/16	10%	18%	21	1	¼	10½	3½
364TS/365TS	2½	3	30%	22½	18	43½	53%	11½	8	41½	2½	1¼/16	10%	20%	22	1	¼	10½	3½	

(*) Maximum - Varies with Enclosure, HP and Motor Manufacturer.

Base Mounted Centrifugal Pumps

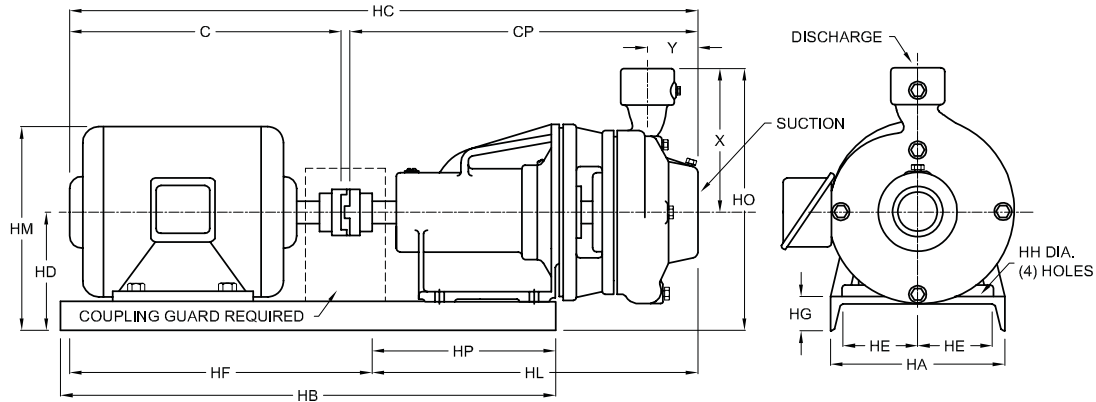

DIMENSIONS IN MILLIMETERS																				
MODEL	MOTOR FRAME	Disc.	Suct.	C*	CP	HA	HB	HC*	HD	HE	HF	HG	HH	HL	HM	HO	HP	HT	X	Y
GNB6-1½	56	1½	2	313	467	254	641	786	178	102	394	64	17	403	295	362	222	6.3	184	70
	143T/145T	1½	2	344	467	254	641	818	178	102	394	64	17	403	276	362	222	6.3	184	70
	182T/184T	1½	2	424	467	254	718	897	178	102	470	64	17	403	287	362	222	6.3	184	70
	213T/215T	1½	2	521	467	305	818	994	197	127	762	64	17	206	343	381	25	6.3	184	70
GNB6-2	56	2	2½	325	470	254	641	802	178	102	394	64	17	406	295	368	222	6.3	191	71
	143T/145T	2	2½	344	470	254	641	821	178	102	394	64	17	406	276	368	222	6.3	191	71
	182T/184T	2	2½	424	470	254	718	900	178	102	470	64	17	406	287	368	222	6.3	191	71
	213T/215T	2	2½	521	470	305	818	997	197	127	762	64	17	210	325	387	25	6.3	191	71
GNB6-2½	56	2½	3	325	487	254	641	819	178	102	394	64	17	424	295	387	222	6.3	210	84
	143T/145T	2½	3	344	487	254	641	838	178	102	394	64	17	424	276	387	222	6.3	210	84
	182T/184T	2½	3	424	487	254	718	918	178	102	470	64	17	424	287	387	222	6.3	210	84
	213T/215T	2½	3	521	487	305	818	1014	197	127	762	64	17	227	325	406	25	6.3	210	84
GNB7-2	56	2	2½	325	492	254	641	824	178	102	394	64	17	429	295	387	222	6.3	210	95
	143T/145T	2	2½	344	492	254	641	843	178	102	394	64	17	429	276	387	222	6.3	210	95
	182T/184T	2	2½	424	492	254	718	922	178	102	470	64	17	429	287	387	222	6.3	210	95
	213T/215T	2	2½	521	492	305	813	1019	197	127	762	64	17	232	325	406	25	6.3	210	95
GNB7-2½	56	2	2½	325	492	254	641	824	178	102	394	64	17	429	295	387	222	6.3	210	95
	143T/145T	2	2½	344	492	254	641	843	178	102	394	64	17	429	276	387	222	6.3	210	95
	182T/184T	2	2½	424	492	254	718	922	178	102	470	64	17	429	287	387	222	6.3	210	95
	213T/215T	2	2½	521	492	305	813	1019	197	127	762	64	17	232	325	406	25	6.3	210	95
GNB9A-1½	56	1½	2	325	475	254	641	806	178	102	394	64	17	411	295	406	222	6.3	229	78
	143T/145T	1½	2	344	475	254	641	826	178	102	394	64	17	411	276	406	222	6.3	229	78
	182T/184T	1½	2	424	475	254	718	905	178	102	470	64	17	411	287	406	222	6.3	229	78
	213T/215T	1½	2	521	475	305	813	1002	197	127	762	64	17	214	325	425	25	6.3	229	78
GNB9-2	143T/145T	2	2½	344	502	254	641	852	178	102	394	64	17	440	276	397	222	6.3	245	102
	182T/184T	2	2½	424	502	254	718	932	178	102	470	64	17	440	287	397	222	6.3	245	102
GNB9-2½	143T/145T	2½	3	344	492	254	641	843	178	102	394	64	17	430	276	445	222	6.3	267	89
	182T/184T	2½	3	424	492	254	718	922	178	102	470	64	17	430	287	445	222	6.3	267	89
	213T/215T	2½	3	521	492	305	813	1019	197	127	762	64	17	233	325	464	25	6.3	267	89
GNC7-2½	213T/215T	2½	3	521	572	305	857	1099	241	127	806	64	17	270	368	438	25	6.3	235	89
	254T/256T	2½	3	632	572	356	965	1210	241	152	914	64	17	270	391	438	25	6.3	235	89
	284TS/286TS	2½	3	668	572	356	1003	1246	241	152	953	64	17	270	416	438	25	6.3	235	89
GNC9-2	213T/215T	2	2½	521	584	305	857	1111	241	127	806	64	17	283	368	460	25	6.3	244	102
	254T/256T	2	2½	632	584	356	965	1222	241	152	914	64	17	283	391	460	25	6.3	244	102
	284TS/286TS	2	2½	668	584	356	1003	1259	241	152	953	64	17	283	416	460	25	6.3	244	102
	324TS/326TS	2	2½	730	584	406	1067	1321	267	178	1016	64	17	283	467	486	25	6.3	244	102
GNC9-2½	254T/256T	2½	3	632	572	356	965	1209	241	152	914	64	17	270	391	508	25	6.3	267	89
	284TS/286TS	2½	3	668	572	356	1003	1246	241	152	953	64	17	270	416	508	25	6.3	267	89
	324TS/326TS	2½	3	730	572	406	1067	1308	267	178	1016	64	17	270	467	533	25	6.3	267	89
	364TS/365TS	2½	3	772	572	457	1105	1349	292	203	1054	64	17	270	518	559	25	6.3	267	89

(*) Maximum - Varies with Enclosure, HP and Motor Manufacturer.

Series: GNB, GNC

Dimensions

Pump Only with Flanged Casing



Base Mounted Centrifugal Pumps

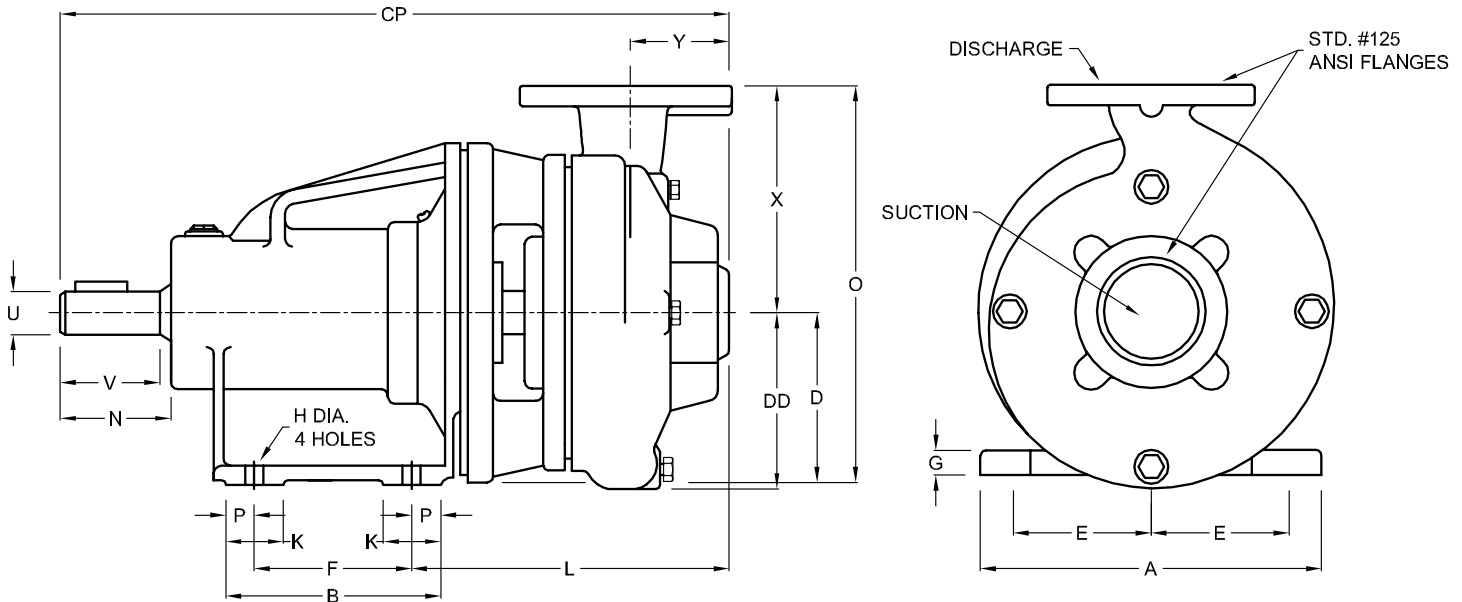

DIMENSIONS IN INCHES																				
MODEL	DISC.	SUCT.	A	B	CP	D	DD	E	F	G	H	K	L	N	O	P	U	V	X	Y
GNB6-2F	2	2½	8	6½	17 ¹³ / ₁₆	4½	4½	3 ⁹ / ₁₆	5	½	5 ⁸ / ₁₆	1½	7 ¹¹ / ₁₆	2 ⁵ / ₈	10½	¾	1 ¹ / ₈	2 ¹¹ / ₁₆	6	2 ⁵ / ₈
GNB6-2½F	2½	3	8	6½	18¼	4½	4 ⁷ / ₈	3 ⁹ / ₁₆	5	½	5 ⁸ / ₁₆	1½	8 ¹ / ₈	2 ⁵ / ₈	11	¾	1 ¹ / ₈	2 ¹¹ / ₁₆	6½	2 ⁵ / ₈
GNB7-2F	2	2½	8	6½	18 ¹ / ₁₆	4½	5	3 ⁹ / ₁₆	5	½	5 ⁸ / ₁₆	1½	7 ¹⁵ / ₁₆	2 ⁵ / ₈	11¼	¾	1 ¹ / ₈	2 ¹¹ / ₁₆	6¾	2 ⁷ / ₁₆
GNB7A-2F	2	2½	8	6½	18¼	4½	5½	3 ⁹ / ₁₆	5	½	5 ⁸ / ₁₆	1½	8 ¹ / ₁₆	2 ⁵ / ₈	12	¾	1 ¹ / ₈	2 ¹¹ / ₁₆	7½	2 ³ / ₈
GNB9-2F	2	2½	8	6½	18 ³ / ₈	4½	5 ⁵ / ₈	3 ⁹ / ₁₆	5	½	5 ⁸ / ₁₆	1½	8 ³ / ₁₆	2 ⁵ / ₈	13	¾	1 ¹ / ₈	2 ¹¹ / ₁₆	8½	2 ⁹ / ₁₆
GNB9-2½F	2½	3	8	6½	18 ⁹ / ₁₆	4½	6	3 ⁹ / ₁₆	5	½	5 ⁸ / ₁₆	1½	8 ⁷ / ₁₆	2 ⁵ / ₈	13¾	¾	1 ¹ / ₈	2 ¹¹ / ₁₆	9¼	2 ⁹ / ₁₆
GNC7-2½F	2½	3	8	6¾	20 ¹³ / ₁₆	7	5½	3 ⁹ / ₁₆	5	½	5 ⁸ / ₁₆	1¾	9 ⁹ / ₁₆	4	14½	7 ¹ / ₈	1 ³ / ₈	3¾	7½	2 ³ / ₈
GNC9-2F	2	2½	8	6¾	21 ⁵ / ₁₆	7	5 ⁵ / ₈	3 ⁹ / ₁₆	5	½	5 ⁸ / ₁₆	1¾	9 ¹ / ₁₆	4	15½	7 ¹ / ₈	1 ³ / ₈	3¾	8½	2 ⁹ / ₁₆
GNC9-2½F	2½	3	8	6¾	21½	7	6	3 ⁹ / ₁₆	5	½	5 ⁸ / ₁₆	1¾	9 ⁷ / ₁₆	4	16¼	7 ¹ / ₈	1 ³ / ₈	3¾	9¼	2 ⁹ / ₁₆
GNB-3F	3	4	8	6½	19	4½	6¼	3 ⁹ / ₁₆	5	½	5 ⁸ / ₁₆	1½	8 ⁷ / ₈	2 ⁵ / ₈	13½	¾	1 ¹ / ₈	2 ¹¹ / ₁₆	9	2 ¹¹ / ₁₆
GNC9-3F	3	4	8	6¾	21 ¹⁵ / ₁₆	7	6¼	3 ⁹ / ₁₆	5	½	5 ⁸ / ₁₆	1¾	10 ⁵ / ₁₆	4	16	7 ¹ / ₈	1 ³ / ₈	3¾	9	2 ¹¹ / ₁₆
GNC9A-3F	3	4	8	6¾	21 ¹⁵ / ₁₆	7	6¼	3 ⁹ / ₁₆	5	½	5 ⁸ / ₁₆	1¾	10 ⁵ / ₁₆	4	16	7 ¹ / ₈	1 ³ / ₈	3¾	9	2 ¹¹ / ₁₆
4GNB9-4F	4	5	8	6½	19 ¹¹ / ₁₆	4½	7 ⁹ / ₁₆	3 ⁹ / ₁₆	5	½	5 ⁸ / ₁₆	1½	9½	2 ⁵ / ₈	15 ⁵ / ₈	¾	1 ¹ / ₈	2 ¹¹ / ₁₆	10 ⁵ / ₈	3¼

DIMENSIONS IN MILLIMETERS																				
MODEL	DISC. (in)	SUCT. (in)	A	B	CP	D	DD	E	F	G	H	K	L	N	O	P	U	V	X	Y
GNB6-2F	2	2½	203	165	452	114	114	90	127	13	16	38	195	73	267	19	29	68	152	54
GNB6-2½F	2½	3	203	165	464	114	124	90	127	13	16	38	206	73	279	19	29	68	165	60
GNB7-2F	2	2½	203	165	459	114	127	90	127	13	16	38	202	73	286	19	29	68	171	62
GNB7A-2F	2	2½	203	165	464	114	140	90	127	13	16	38	205	73	305	19	29	68	191	60
GNB9-2F	2	2½	203	165	467	114	149	90	127	13	16	38	208	73	330	19	29	68	216	65
GNB9-2½F	2½	3	203	165	471	114	152	90	127	13	16	38	214	73	349	19	29	68	235	65
GNC7-2½F	2½	3	203	172	529	178	140	90	127	13	16	44	233	102	368	22	35	95	191	60
GNC9-2F	2	2½	203	172	541	178	149	90	127	13	16	44	246	102	394	22	35	95	216	65
GNC9-2½F	2½	3	203	172	546	178	152	90	127	13	16	44	251	102	413	22	35	95	235	65
GNB-3F	3	4	203	165	483	114	159	90	127	13	16	38	225	73	343	19	29	68	229	68
GNC9-3F	3	4	203	172	557	178	159	90	127	13	16	44	262	102	406	22	35	95	229	68
GNC9A-3F	3	4	203	172	557	178	159	90	127	13	16	44	262	102	406	22	35	95	229	68
4GNB9-4F	3	5	203	165	500	114	192	90	127	13	16	38	241	73	384	19	29	68	270	83

SECTION 3B
PAGE 8
DATE 1/06



A Crane Co. Company

PUMPS & SYSTEMS

USA: (937) 778-8947 • Canada: (905) 457-6223 • International: (937) 615-3598

Base Mounted Centrifugal Pumps

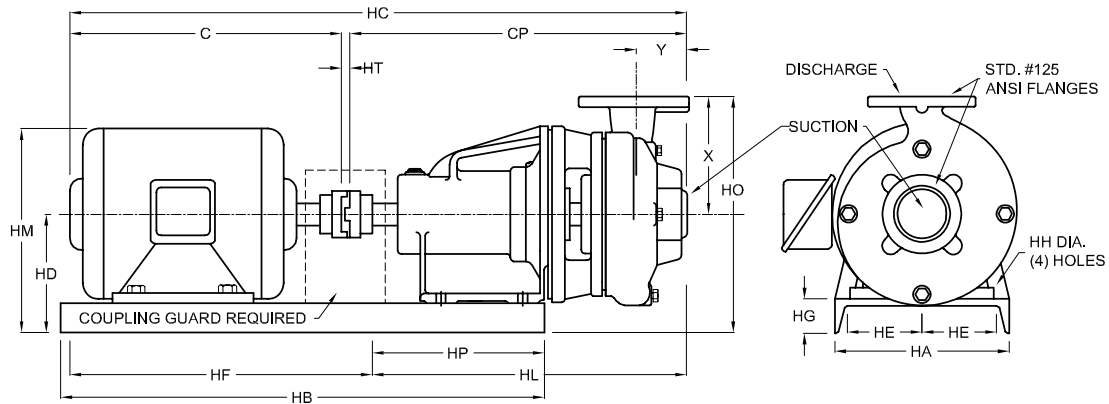

DIMENSIONS IN INCHES

MODEL	MOTOR FRAME	Disc.	Suct.	C*	CP	HA	HB	HC*	HD	HE	HF	HG	HH	HL	HM	HO	HP	HT	X	Y
GNB6-2F	56	2	2½	12 ¹³ / ₁₆	17 ¹³ / ₁₆	10	25¼	31 ⁵ / ₈	7	4	15½	2½	1 ¹ / ₁₆	15 ¹⁵ / ₁₆	11 ⁵ / ₈	13	8¾	½	6	2 ¹ / ₈
	143T/145T	2	2½	13 ⁹ / ₁₆	17 ¹³ / ₁₆	10	25¼	31 ⁵ / ₈	7	4	15½	2½	1 ¹ / ₁₆	15 ¹⁵ / ₁₆	10 ⁷ / ₈	13	8¾	½	6	2 ¹ / ₈
	182T/184T	2	2½	16 ¹ / ₁₆	17 ¹³ / ₁₆	10	28¼	35	7	4	18½	2½	1 ¹ / ₁₆	15 ¹⁵ / ₁₆	11 ⁵ / ₈	13	8¾	½	6	2 ¹ / ₈
	213T/215T	2	2½	20½	17 ¹³ / ₁₆	12	32	39 ¹ / ₁₆	7¾	5	30	2½	1 ¹ / ₁₆	7 ⁹ / ₁₆	12 ¹³ / ₁₆	13¾	1	¾	6	2 ¹ / ₈
GNB6-2½F	56	2½	3	12 ¹³ / ₁₆	18¼	10	25¼	31 ⁵ / ₈	7	4	15½	2½	1 ¹ / ₁₆	15¼	11 ⁵ / ₈	13½	8¾	½	6½	2 ¹ / ₈
	143T/145T	2½	3	13 ⁹ / ₁₆	18¼	10	25¼	32 ⁵ / ₈	7	4	15½	2½	1 ¹ / ₁₆	15¼	10 ⁷ / ₈	13½	8¾	½	6½	2 ¹ / ₈
	182T/184T	2½	3	16 ¹ / ₁₆	18¼	10	28¼	35 ⁵ / ₈	7	4	18½	2½	1 ¹ / ₁₆	15¼	11 ⁵ / ₈	13½	8¾	½	6½	2 ¹ / ₈
	213T/215T	2½	3	20½	18¼	12	32	39½	7¾	5	30	2½	1 ¹ / ₁₆	8	12 ¹³ / ₁₆	14¼	1	¾	6½	2 ¹ / ₈
	254T/256T	2½	3	24 ⁷ / ₈	18¼	14	36½	44	8¾	6	34½	2½	1 ¹ / ₁₆	8	14 ⁵ / ₈	15¼	1	¾	6½	2 ¹ / ₈
GNB7-2F GNB7A-2F	56	2	2½	12 ¹³ / ₁₆	18 ¹ / ₁₆	10	25¼	31 ⁵ / ₈	7	4	15½	2½	1 ¹ / ₁₆	15 ¹⁵ / ₁₆	11 ⁵ / ₈	13¾	8¾	½	6¼	2 ¹ / ₁₆
	143T/145T	2	2½	13 ⁹ / ₁₆	18 ¹ / ₁₆	10	25¼	32 ⁵ / ₈	7	4	15½	2½	1 ¹ / ₁₆	15 ¹⁵ / ₁₆	10 ⁷ / ₈	13¾	8¾	½	6¼	2 ¹ / ₁₆
	182T/184T	2	2½	16 ¹ / ₁₆	18 ¹ / ₁₆	10	28¼	35¼	7	4	18½	2½	1 ¹ / ₁₆	15 ¹⁵ / ₁₆	11 ⁵ / ₈	13¾	8¾	½	6¼	2 ¹ / ₁₆
	213T/215T	2	2½	20½	18 ¹ / ₁₆	12	32	39 ⁵ / ₈	7¾	5	30	2½	1 ¹ / ₁₆	7 ⁹ / ₁₆	12 ¹³ / ₁₆	14½	1	¾	6¼	2 ¹ / ₁₆
	254T/256T	2	2½	24 ⁷ / ₈	18 ¹ / ₁₆	14	36½	43 ¹³ / ₁₆	8¾	6	34½	2½	1 ¹ / ₁₆	7 ⁹ / ₁₆	14 ⁵ / ₈	15½	1	¾	6¼	2 ¹ / ₁₆
GNB7-2½F	143T/145T	2½	3	13 ⁹ / ₁₆	18¼	10	25¼	32 ⁵ / ₈	7	4	15½	2½	1 ¹ / ₁₆	15 ¹⁵ / ₁₆	10 ⁷ / ₈	14½	8¾	½	7½	2 ¹ / ₈
	182T/184T	2½	3	16 ¹ / ₁₆	18¼	10	28¼	35 ⁵ / ₈	7	4	18½	2½	1 ¹ / ₁₆	15 ¹⁵ / ₁₆	11 ⁵ / ₈	14½	8¾	½	7½	2 ¹ / ₈
GNB9-2F	143T/145T	2	2½	13 ⁹ / ₁₆	18 ¹ / ₁₆	10	25¼	32 ⁵ / ₈	7	4	15½	2½	1 ¹ / ₁₆	15 ¹⁵ / ₁₆	10 ⁷ / ₈	15½	8¾	½	8½	2 ¹ / ₁₆
	182T/184T	2	2½	16 ¹ / ₁₆	18 ¹ / ₁₆	10	28¼	35 ⁵ / ₈	7	4	18½	2½	1 ¹ / ₁₆	15 ¹⁵ / ₁₆	11 ⁵ / ₈	15½	8¾	½	8½	2 ¹ / ₁₆
GNB9-2½F	143T/145T	2½	3	13 ⁹ / ₁₆	18 ¹ / ₁₆	10	25¼	32 ⁵ / ₈	7	4	15½	2½	1 ¹ / ₁₆	16 ³ / ₁₆	10 ⁷ / ₈	16¼	8¾	½	9¼	2 ¹ / ₁₆
	182T/184T	2½	3	16 ¹ / ₁₆	18 ¹ / ₁₆	10	28¼	35 ⁵ / ₈	7	4	18½	2½	1 ¹ / ₁₆	16 ³ / ₁₆	11 ⁵ / ₈	16¼	8¾	½	9¼	2 ¹ / ₁₆
	213T/215T	2½	3	20½	18 ¹ / ₁₆	12	32	39 ⁵ / ₈	7¾	5	30	2½	1 ¹ / ₁₆	8 ¹ / ₁₆	12 ¹³ / ₁₆	17	1	¾	9¼	2 ¹ / ₁₆
GNC7-2½F	213T/215T	2½	3	20½	20 ¹³ / ₁₆	12	33¼	42 ¹ / ₁₆	9½	5	31¼	2½	1 ¹ / ₁₆	9 ¹ / ₁₆	14½	17	1	¾	7½	2 ¹ / ₈
	254T/256T	2½	3	24 ⁷ / ₈	20 ¹³ / ₁₆	14	38	49 ¹ / ₁₆	9½	6	36	2½	1 ¹ / ₁₆	9 ¹ / ₁₆	15 ⁵ / ₈	17	1	¾	7½	2 ¹ / ₈
	284TS/286TS	2½	3	26 ⁹ / ₁₆	20 ¹³ / ₁₆	14	39½	48	9½	6	37½	2½	1 ¹ / ₁₆	9 ¹ / ₁₆	16 ³ / ₈	17	1	¾	7½	2 ¹ / ₈
	324TS/326TS	2	2½	20½	21 ⁵ / ₁₆	12	33¼	42 ¹ / ₁₆	9½	5	31¼	2½	1 ¹ / ₁₆	10 ¹¹ / ₁₆	14½	18	1	¾	8½	2 ¹ / ₁₆
GNC9-2F	254T/256T	2	2½	24 ⁷ / ₈	21 ⁵ / ₁₆	14	38	47 ¹ / ₁₆	9½	6	36	2½	1 ¹ / ₁₆	10 ¹¹ / ₁₆	15 ⁵ / ₈	18	1	¾	8½	2 ¹ / ₁₆
	284TS/286TS	2	2½	26 ⁹ / ₁₆	21 ⁵ / ₁₆	14	39½	48½	9½	6	37½	2½	1 ¹ / ₁₆	10 ¹¹ / ₁₆	16 ³ / ₈	18	1	¾	8½	2 ¹ / ₁₆
	324TS/326TS	2	2½	28¾	21 ⁵ / ₁₆	16	42	51 ¹ / ₁₆	10½	7	40	2½	1 ¹ / ₁₆	10 ¹¹ / ₁₆	18 ³ / ₈	19	1	1	8½	2 ¹ / ₁₆
	254T/256T	2½	3	24 ⁷ / ₈	21½	14	38	47¼	9½	6	36	2½	1 ¹ / ₁₆	9¼	15 ⁵ / ₈	18¾	1	¾	9¼	2 ¹ / ₁₆
	284TS/286TS	2½	3	26 ⁹ / ₁₆	21½	14	39½	48 ¹ / ₁₆	9½	6	37½	2½	1 ¹ / ₁₆	9¼	16 ³ / ₈	18¾	1	¾	9¼	2 ¹ / ₁₆
GNC9-2½F	324TS/326TS	2½	3	28¾	21½	16	42	51¼	10½	7	40	2½	1 ¹ / ₁₆	9¼	18 ³ / ₈	19¾	1	1	9¼	2 ¹ / ₁₆
	364TS/365TS	2½	3	30 ³ / ₈	21½	18	43½	52 ³ / ₈	11½	8	41½	2½	1 ¹ / ₁₆	9¼	20 ³ / ₈	20¾	1	1	9¼	2 ¹ / ₁₆
	182T/184T	3	4	16 ¹ / ₁₆	19	10	28¼	36 ³ / ₁₆	7	4	18½	2½	1 ¹ / ₁₆	16 ³ / ₁₆	11 ⁵ / ₈	16	8¾	½	9	2 ¹¹ / ₁₆
	213T/215T	3	4	20½	19	12	32	40¼	7¾	5	30	2½	1 ¹ / ₁₆	8 ⁵ / ₁₆	12 ¹³ / ₁₆	16¾	1	¾	9	2 ¹¹ / ₁₆
	254T/256T	3	4	24 ⁷ / ₈	19	14	36½	44¼	8¾	6	34½	2½	1 ¹ / ₁₆	8 ⁵ / ₁₆	14 ⁵ / ₈	16¾	1	¾	9	2 ¹¹ / ₁₆
GNC9-3F GNC9A-3F	254T/256T	3	4	24 ⁷ / ₈	21 ⁵ / ₁₆	14	38	47 ¹ / ₁₆	9½	6	36	2½	1 ¹ / ₁₆	10 ¹¹ / ₁₆	15 ⁵ / ₈	18½	1	¾	9	2 ¹¹ / ₁₆
	284TS/286TS	3	4	26 ⁹ / ₁₆	21 ⁵ / ₁₆	14	39½	49 ¹ / ₁₆	9½	6	37½	2½	1 ¹ / ₁₆	10 ¹¹ / ₁₆	16 ³ / ₈	18½	1	¾	9	2 ¹¹ / ₁₆
	324TS/326TS	3	4	28¾	21 ⁵ / ₁₆	16	42	51 ¹ / ₁₆	10½	7	40	2½	1 ¹ / ₁₆	10 ¹¹ / ₁₆	18 ³ / ₈	19½	1	1	9	2 ¹¹ / ₁₆
	364TS/365TS	3	4	30 ³ / ₈	21 ⁵ / ₁₆	18	43½	53 ³ / ₈	11½	8	41½	2½	1 ¹ / ₁₆	10 ¹¹ / ₁₆	20 ³ / ₈	20½	1	1	9	2 ¹¹ / ₁₆
	182T/184T	4	5	18 ¹ / ₁₆	19 ¹ / ₁₆	10	28¼	38¼	7	4	18½	2½	1 ¹ / ₁₆	17 ¹ / ₁₆	12 ¹³ / ₁₆	17 ⁵ / ₈	8¾	½	10 ³ / ₈	3¼
4GNB9-4F	213T/215T	4	5	19¾	19 ¹ / ₁₆	12	32	40 ¹ / ₁₆	7¾	5	30	2½	1 ¹ / ₁₆	9 ⁵ / ₁₆	13 ⁵ / ₈	18 ³ / ₈	1	¾	10 ³ / ₈	3¼
	254T/256T	4	5	24 ⁷ / ₈	19 ¹ / ₁₆	14	36½	45 ¹ / ₁₆	8¾	6	34½	2½	1 ¹ / ₁₆	9 ⁵ / ₁₆	15 ¹¹ / ₁₆	19 ³ / ₈	1	¾	10 ³ / ₈	3¼

(*) Maximum - Varies with Enclosure, HP and Motor Manufacturer.

Base Mounted Centrifugal Pumps

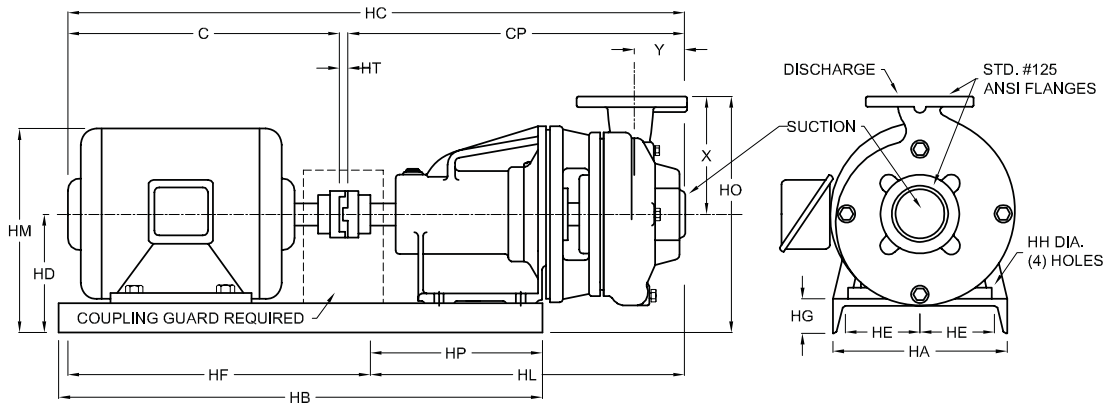

DIMENSIONS IN MILLIMETERS

MODEL	MOTOR FRAME	Disc.	Suct.	C*	CP	HA	HB	HC*	HD	HE	HF	HG	HH	HL	HM	HO	HP	HT	X	Y
GNB6-2F	56	2	2½	325	452	254	641	791	178	102	394	64	17	389	295	330	222	13	152	54
	143T/145T	2	2½	344	452	254	641	810	178	102	394	64	17	389	276	330	222	13	152	54
	182T/184T	2	2½	424	452	254	718	889	178	102	470	64	17	389	287	330	222	13	152	54
	213T/215T	2	2½	521	452	305	813	992	197	127	762	64	17	192	325	349	25	19	152	54
GNB6-2½F	56	2½	3	325	464	254	641	802	178	102	394	64	17	400	295	343	222	13	165	60
	143T/145T	2½	3	344	464	254	641	821	178	102	394	64	17	400	276	343	222	13	165	60
	182T/184T	2½	3	424	464	254	718	900	178	102	470	64	17	400	287	343	222	13	165	60
	213T/215T	2½	3	521	464	305	813	1003	197	127	762	64	17	203	325	362	25	19	165	60
	254T/256T	2½	3	632	464	356	927	1118	222	152	876	64	17	203	371	387	25	22	165	60
GNB7-2F GNB7A-2F	56	2	2½	325	459	254	641	797	178	102	394	64	17	395	295	349	222	13	171	62
	143T/145T	2	2½	344	459	254	641	816	178	102	394	64	17	395	276	349	222	13	171	62
	182T/184T	2	2½	424	459	254	718	895	178	102	470	64	17	395	287	349	222	13	171	62
	213T/215T	2	2½	521	459	305	813	999	197	127	762	64	17	198	325	368	25	19	171	62
GNB7-2½F	143T/145T	2½	3	344	464	254	641	821	178	102	394	64	17	398	276	368	222	13	191	60
	182T/184T	2½	3	424	464	254	718	900	178	102	470	64	17	398	287	368	222	13	191	60
GNB9-2F	143T/145T	2	2½	344	467	254	641	824	178	102	394	64	17	402	276	394	222	13	216	65
	182T/184T	2	2½	424	467	254	718	903	178	102	470	64	17	402	287	394	222	13	216	65
GNB9-2½F	143T/145T	2½	3	344	472	254	641	829	178	102	394	64	17	411	276	413	222	13	235	65
	182T/184T	2½	3	424	472	254	718	908	178	102	470	64	17	411	287	413	222	13	235	65
	213T/215T	2½	3	521	472	305	813	1011	197	127	762	64	17	214	325	432	25	19	235	65
GNC7-2½F	213T/215T	2½	3	521	529	305	857	1068	241	127	806	64	17	230	368	432	25	19	191	60
	254T/256T	2½	3	632	529	356	965	1183	241	152	914	64	17	230	391	432	25	22	191	60
	284TS/286TS	2½	3	668	529	356	1003	1219	241	152	953	64	17	230	416	432	25	22	191	60
GNC9-2F	213T/215T	2	2½	521	541	305	857	1081	241	127	806	64	17	271	368	457	25	19	216	65
	254T/256T	2	2½	632	541	356	965	1195	241	152	914	64	17	271	391	457	25	22	216	65
	284TS/286TS	2	2½	668	541	356	1003	1232	241	152	953	64	17	271	416	457	25	22	216	65
	324TS/326TS	2	2½	730	541	406	1067	1297	267	178	1016	64	17	271	467	483	25	25	216	65
GNC9-2½F	254T/256T	2½	3	632	546	356	965	1200	241	152	914	64	17	248	391	476	25	22	235	65
	284TS/286TS	2½	3	668	546	356	1003	1237	241	152	953	64	17	248	416	476	25	22	235	65
	324TS/326TS	2½	3	730	546	406	1067	1302	267	178	1016	64	17	248	467	502	25	25	235	65
	364TS/365TS	2½	3	772	546	457	1105	1343	292	203	1054	64	17	248	518	527	25	25	235	65
GNB9-3F	182T/184T	3	4	424	483	254	718	919	178	102	470	64	17	416	287	406	222	13	229	68
	213T/215T	3	4	521	483	305	813	1022	197	127	762	64	17	219	325	425	25	19	229	68
GNC9-3F GNC9A-3F	254T/256T	3	4	632	557	356	965	1211	241	152	914	64	17	259	391	470	25	22	229	68
	284TS/286TS	3	4	668	557	356	1003	1248	241	152	953	64	17	259	416	470	25	22	229	68
	324TS/326TS	3	4	730	557	406	1067	1313	267	178	1016	64	17	259	467	495	25	25	229	68
	364TS/365TS	3	4	772	557	457	1105	1354	292	203	1054	64	17	259	518	521	25	25	229	68
4GNB9-4F	182T/184T	4	5	459	500	254	718	972	178	102	470	64	17	435	310	448	222	13	270	83
	213T/215T	4	5	502	500	305	813	1021	197	127	762	64	17	238	346	448	25	19	270	83
	254T/256T	4	5	632	500	356	927	1154	222	152	876	64	17	238	398	448	25	22	270	83

(*) Maximum - Varies with Enclosure, HP and Motor Manufacturer.

Base Mounted Centrifugal Pumps

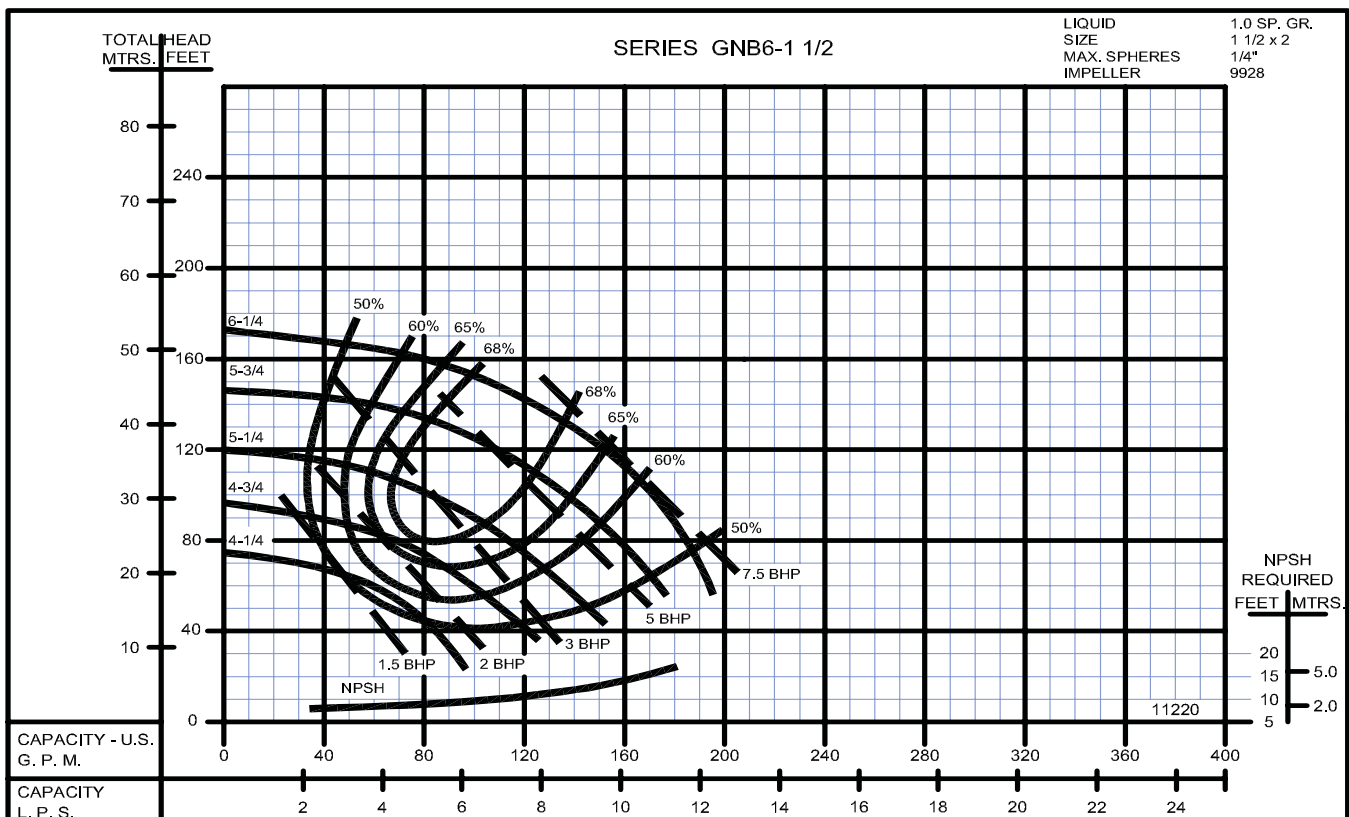
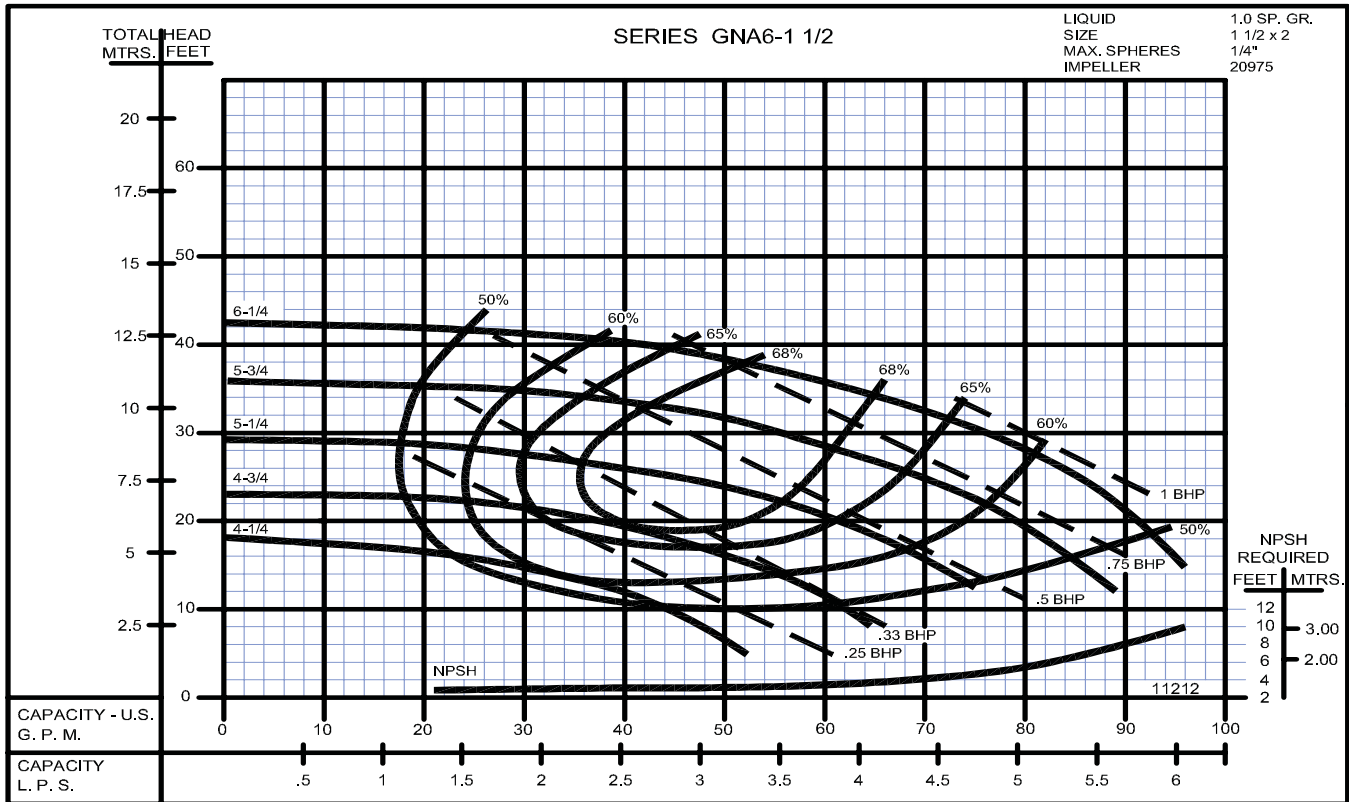

Base Mounted Centrifugal Pumps

1750 RPM

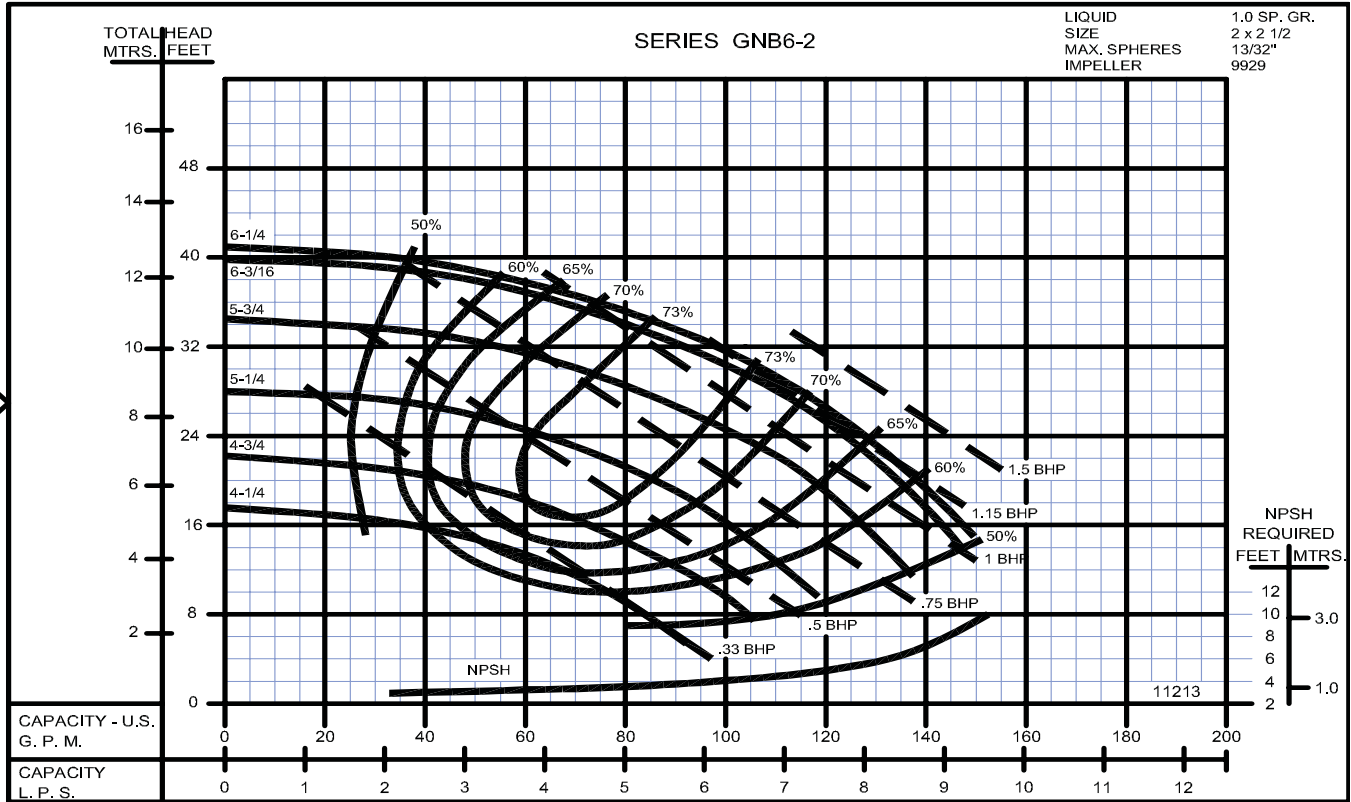

3500 RPM

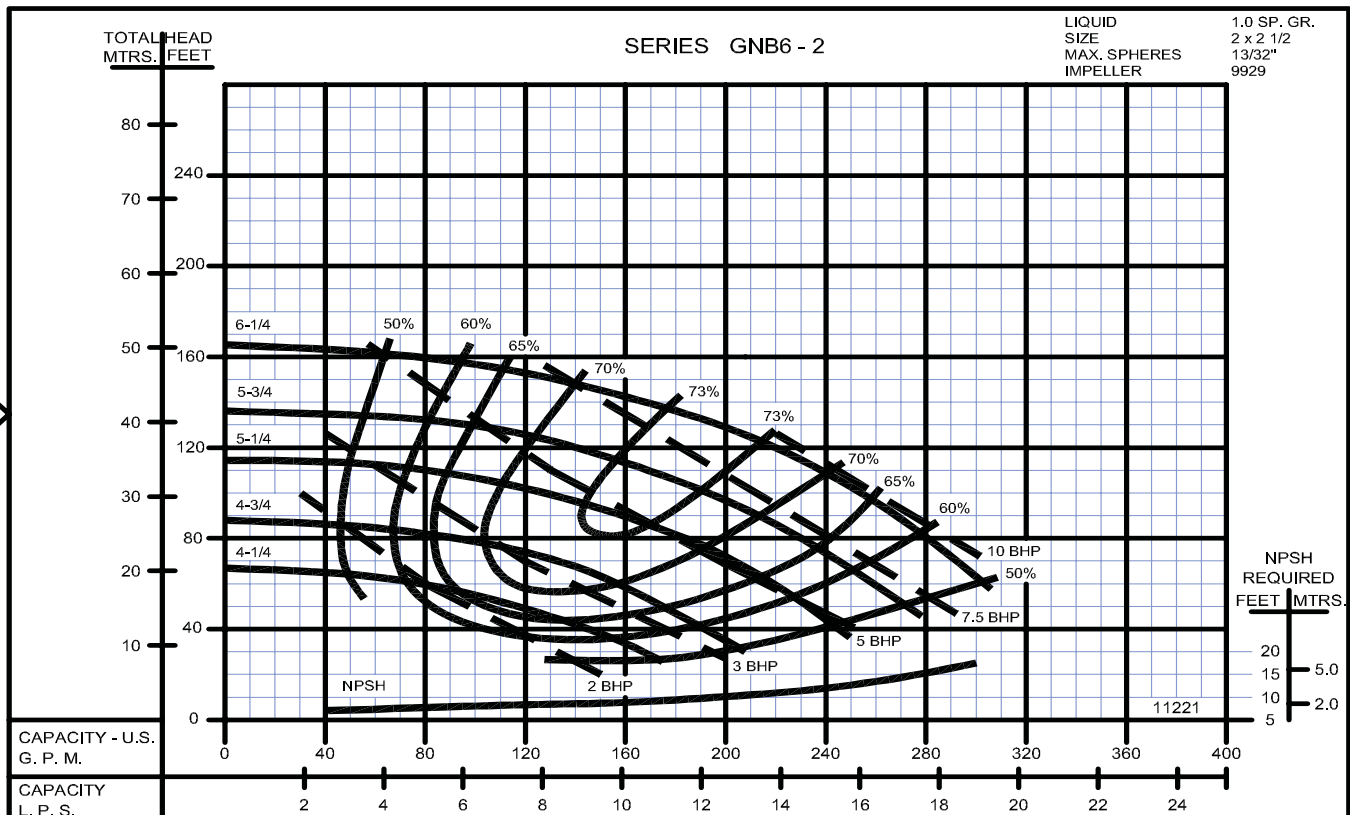

SECTION 3B
PAGE 12
DATE 1/06



PUMPS & SYSTEMS

A Crane Co. Company

USA: (937) 778-8947 • Canada: (905) 457-6223 • International: (937) 615-3598

Base Mounted Centrifugal Pumps

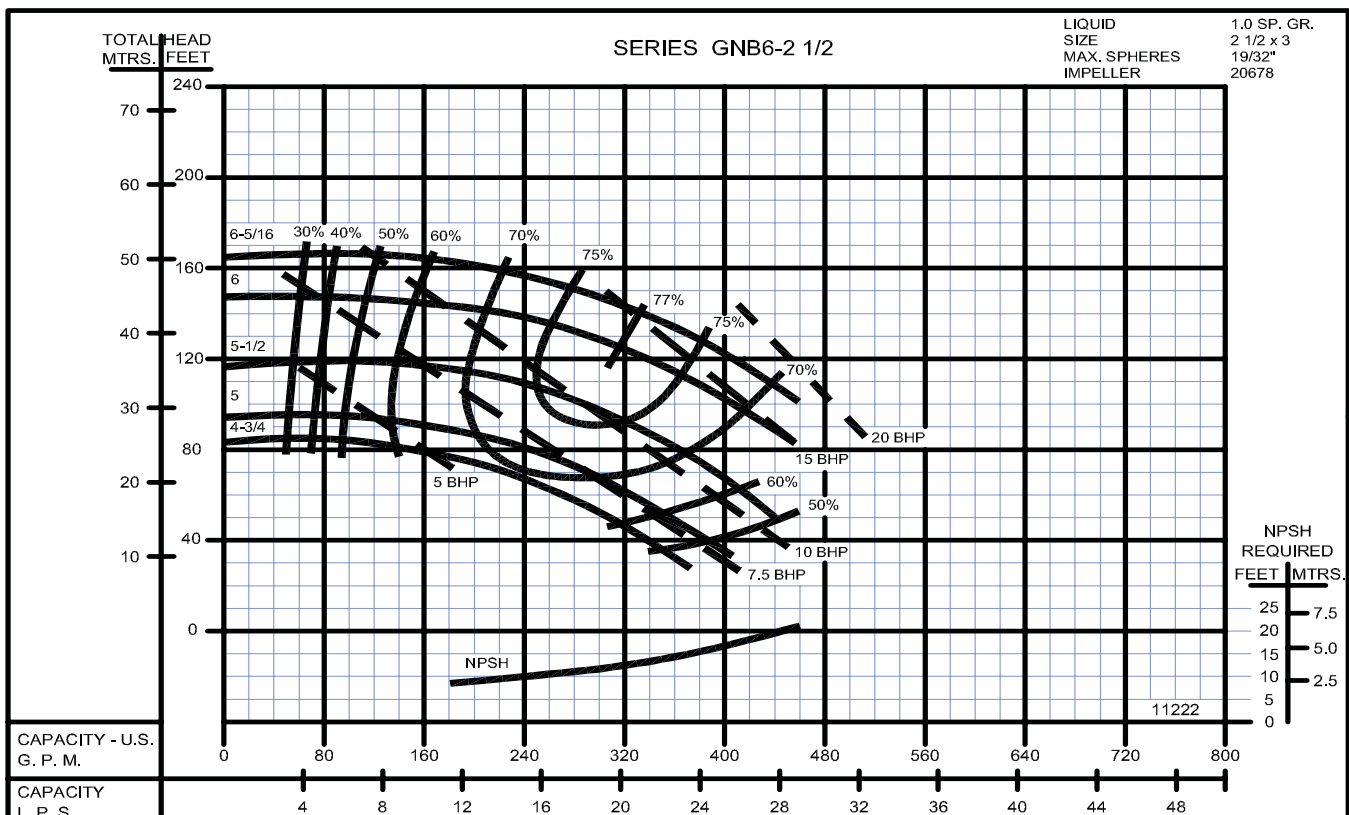
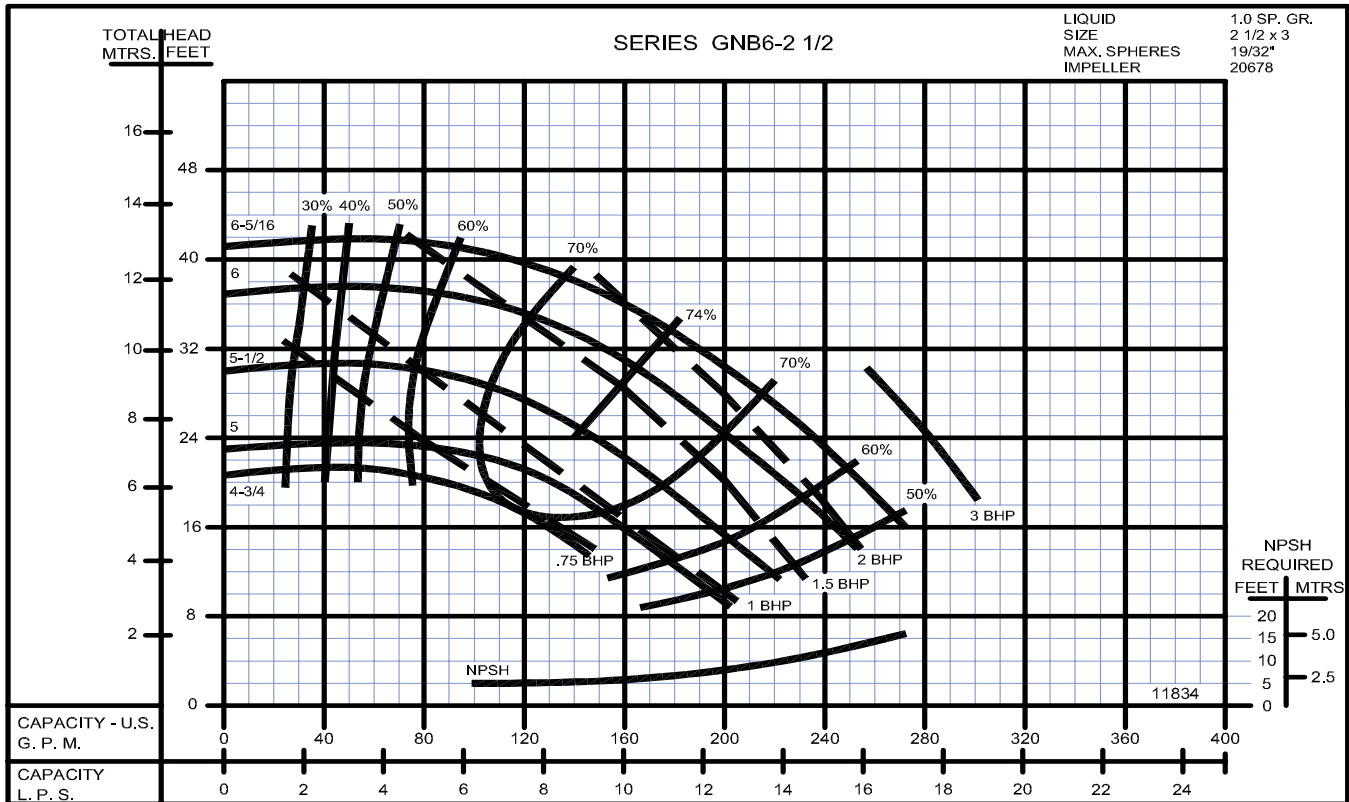

Base Mounted Centrifugal Pumps

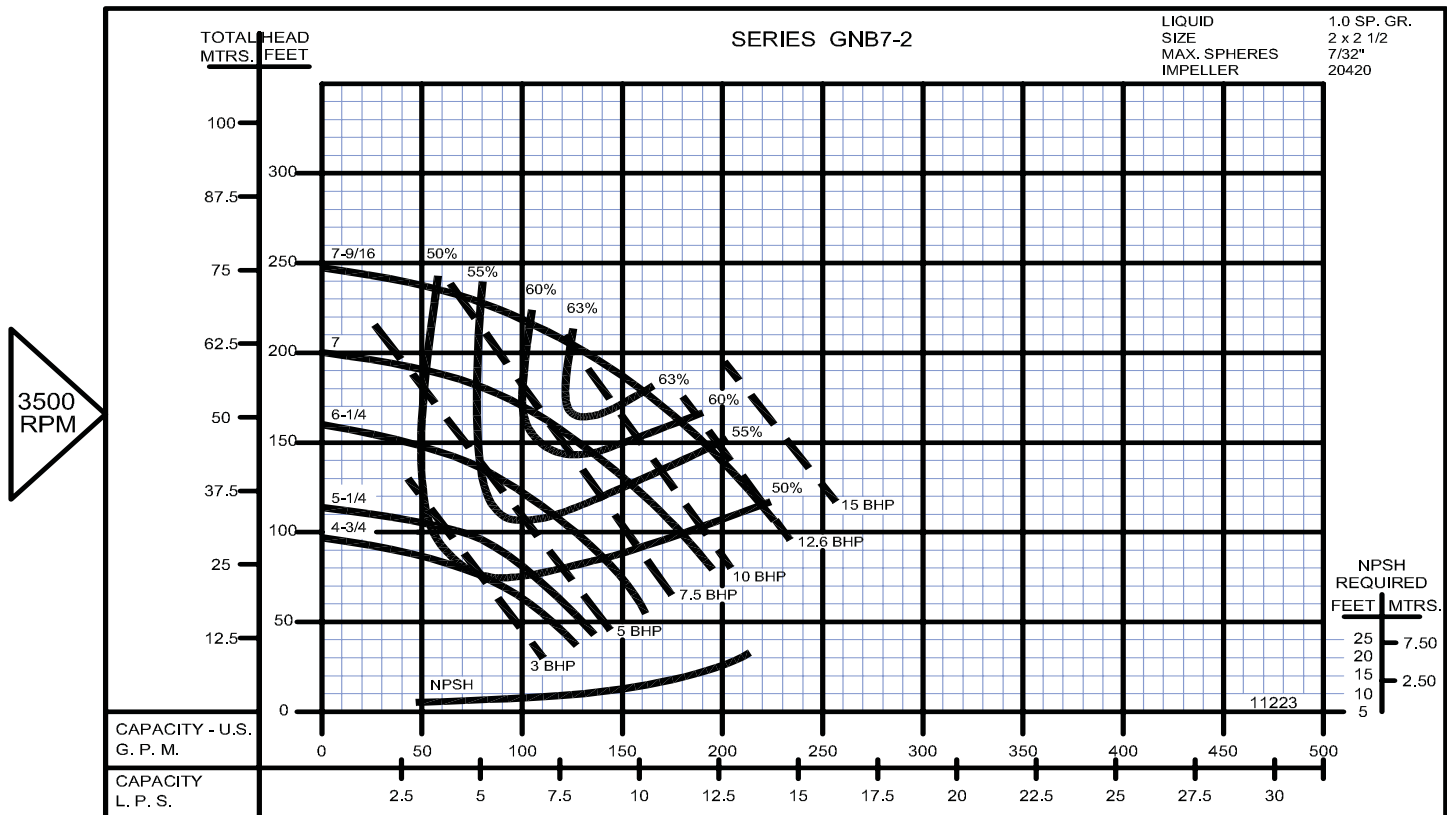
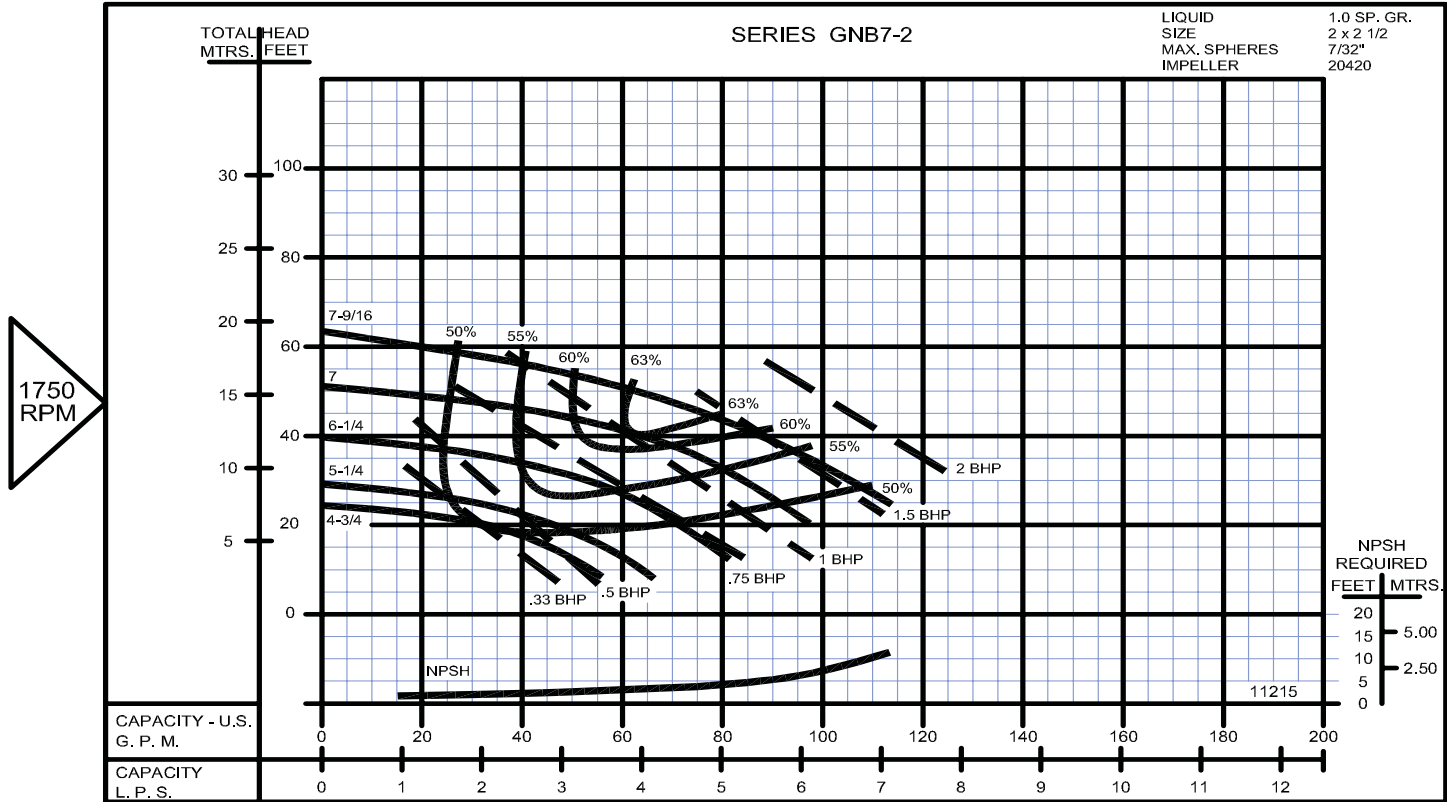

SECTION 3B
PAGE 14
DATE 1/06



A Crane Co. Company

PUMPS & SYSTEMS

USA: (937) 778-8947 • Canada: (905) 457-6223 • International: (937) 615-3598

Base Mounted Centrifugal Pumps

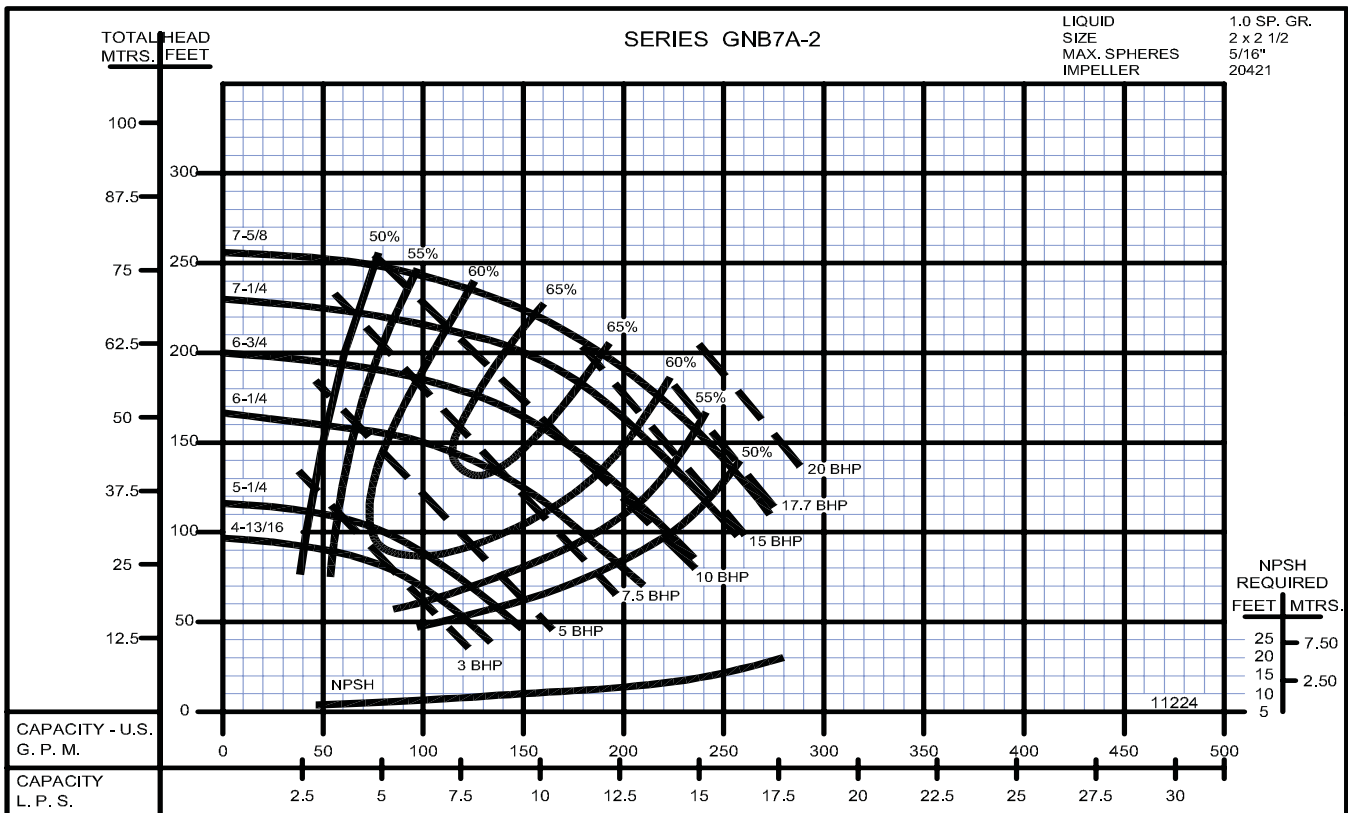
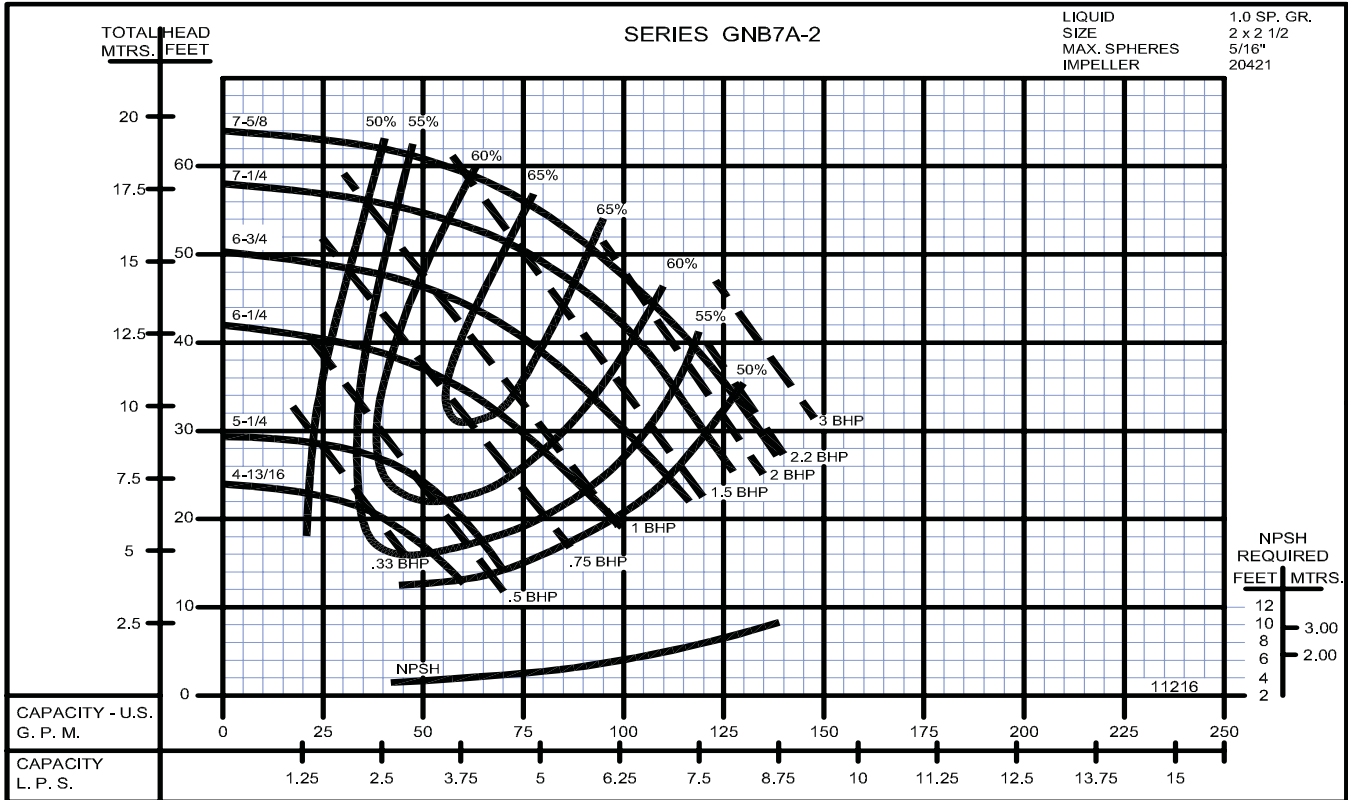

Base Mounted Centrifugal Pumps

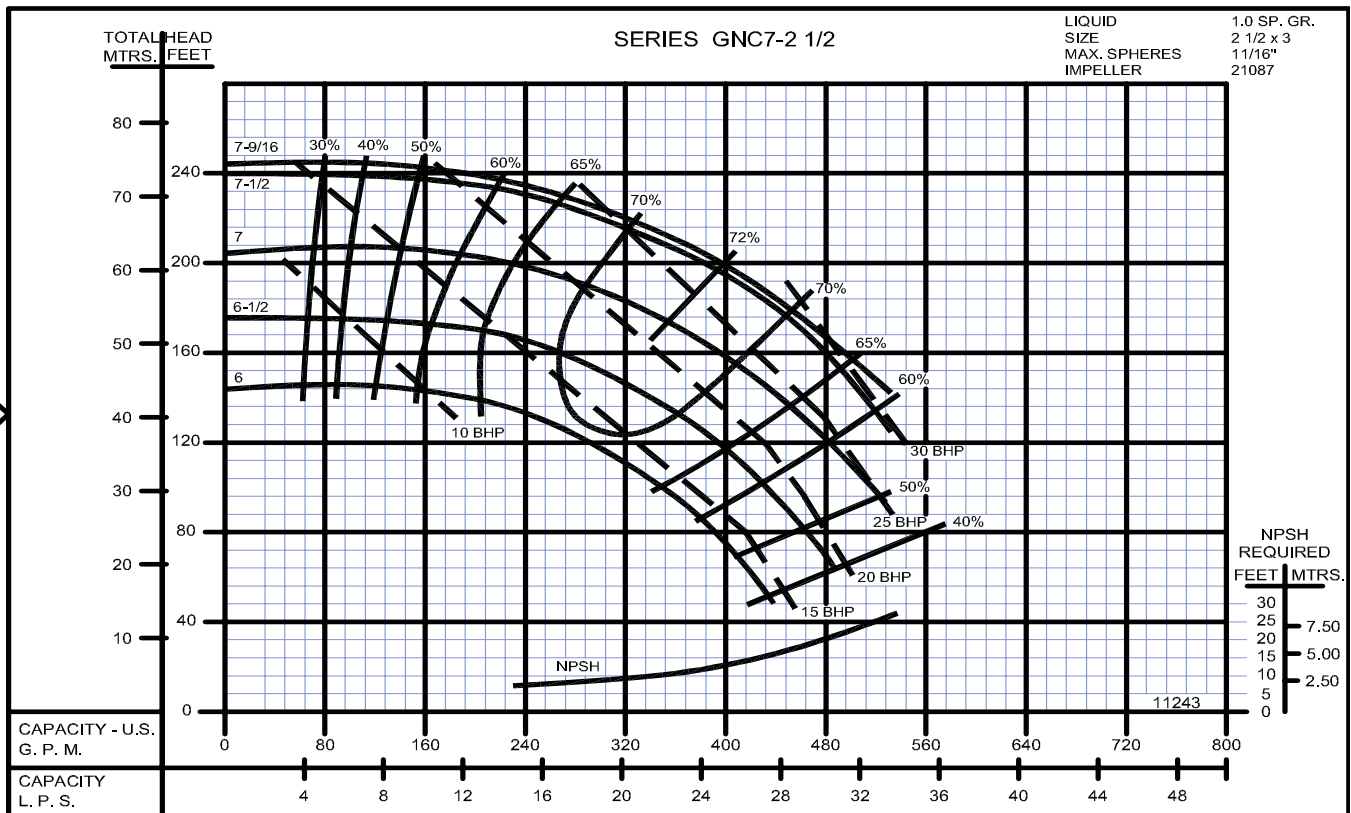
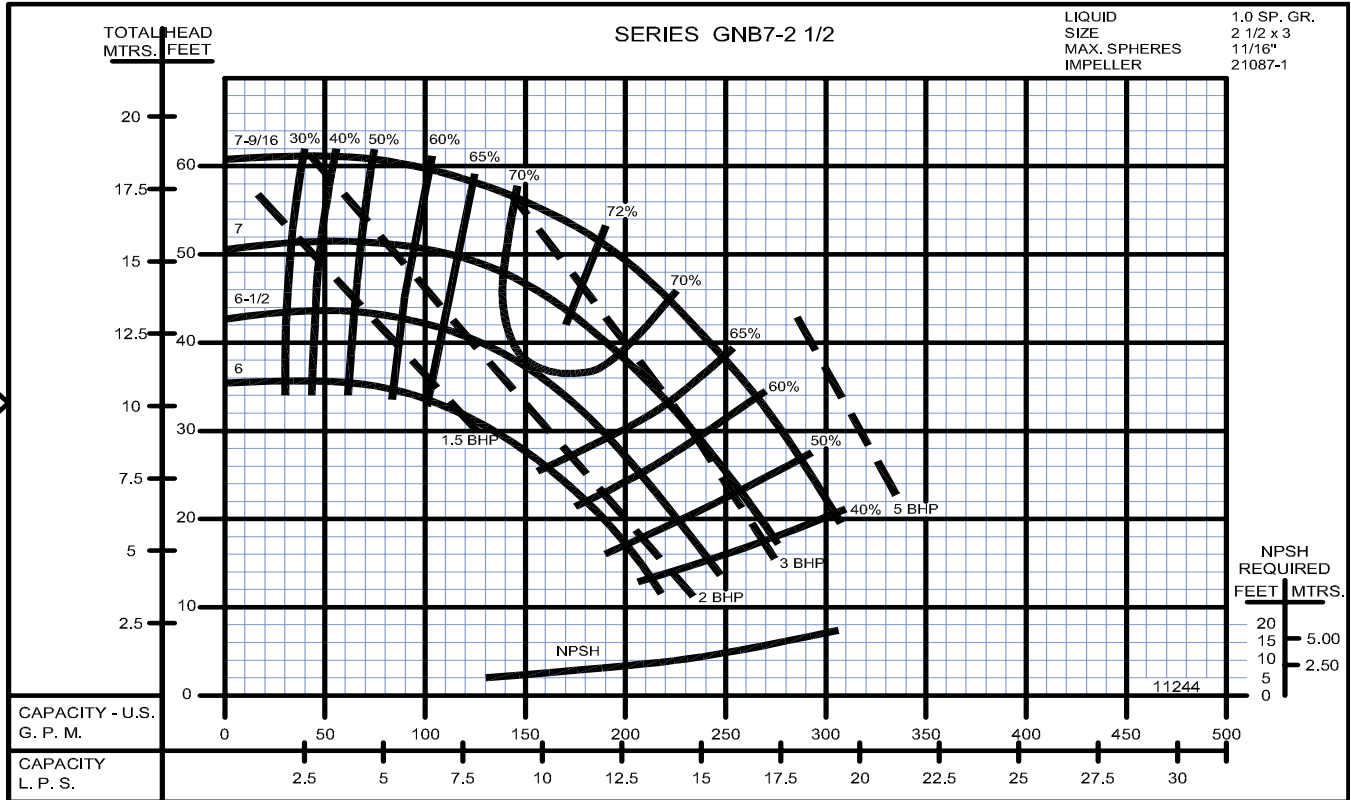

SECTION 3B
PAGE 16
DATE 1/06

CRANE[®]

A Crane Co. Company

PUMPS & SYSTEMS

USA: (937) 778-8947 • Canada: (905) 457-6223 • International: (937) 615-3598

Base Mounted Centrifugal Pumps

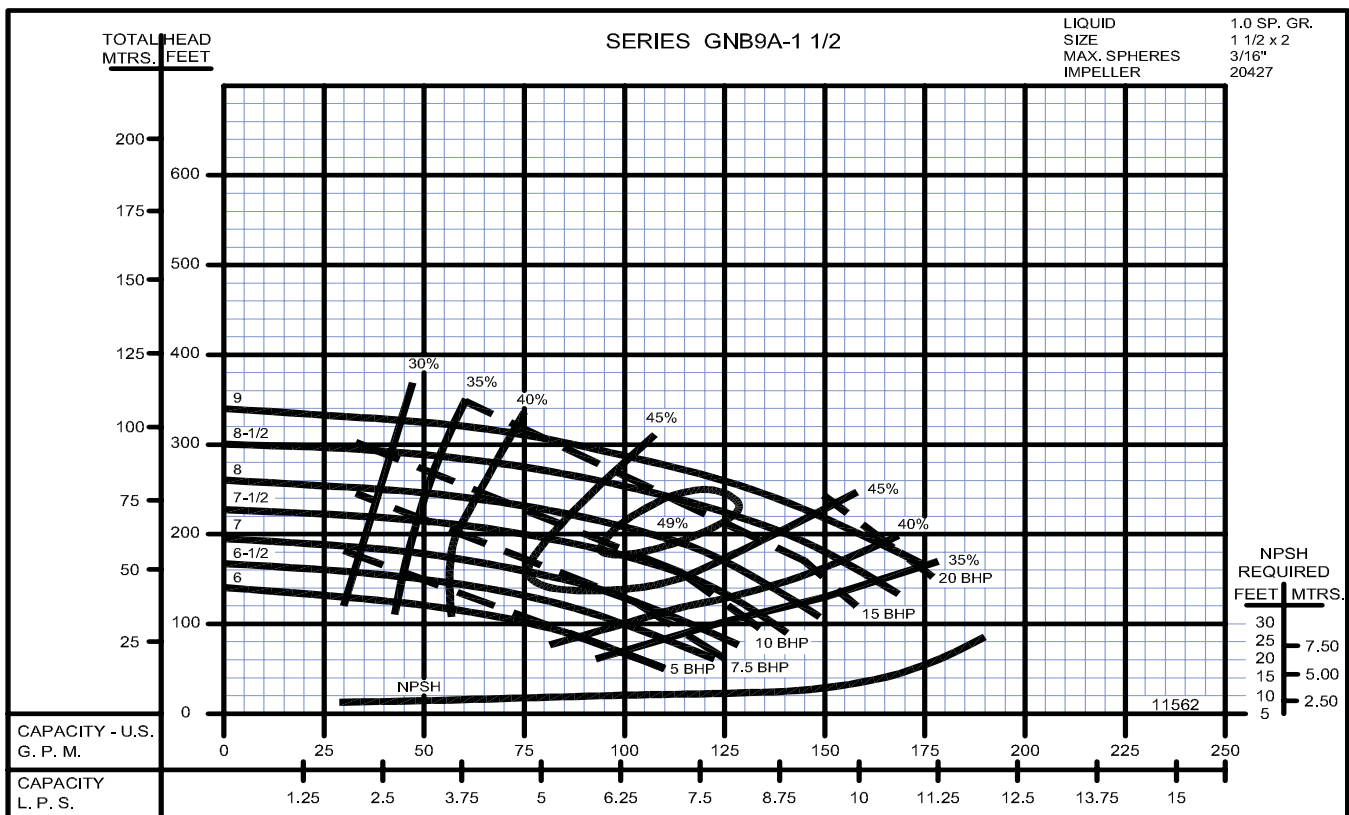
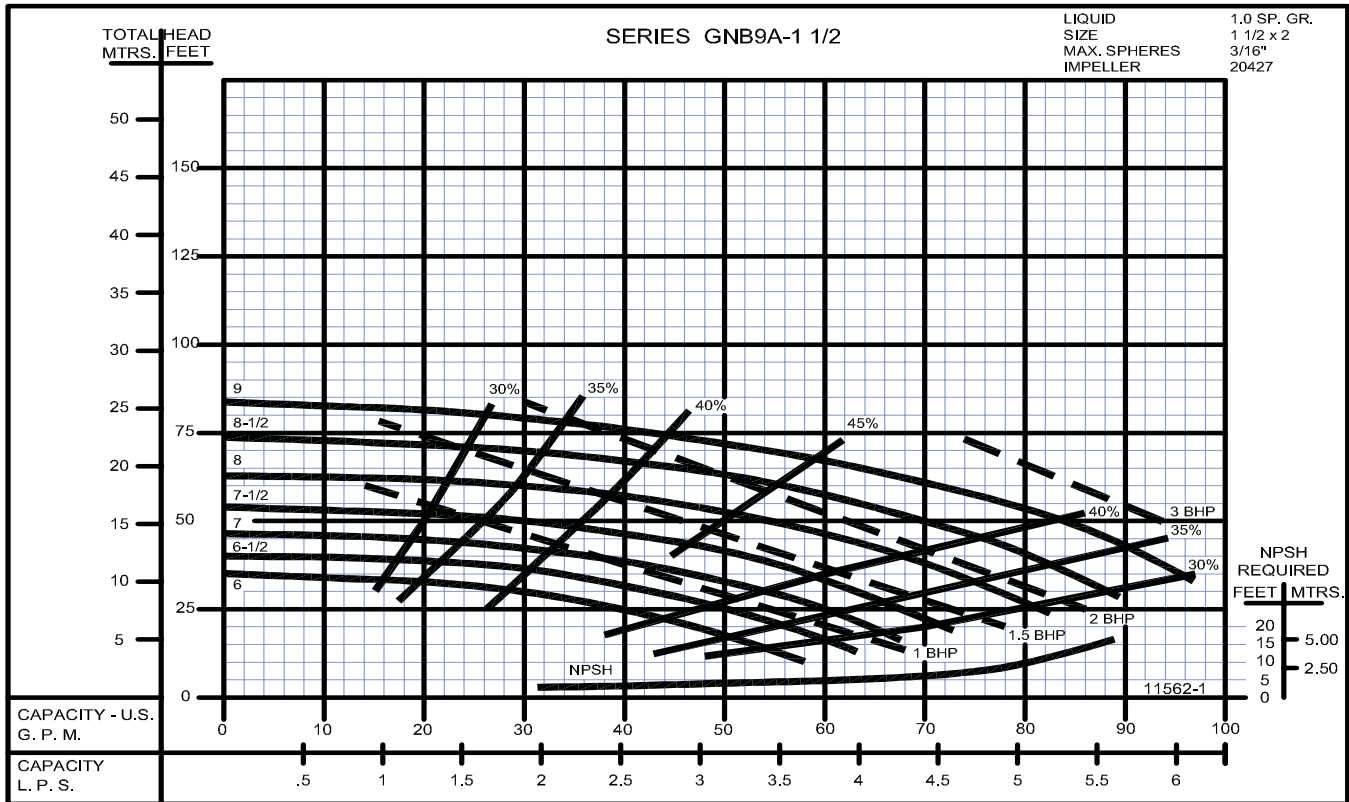

Base Mounted Centrifugal Pumps

1750 RPM

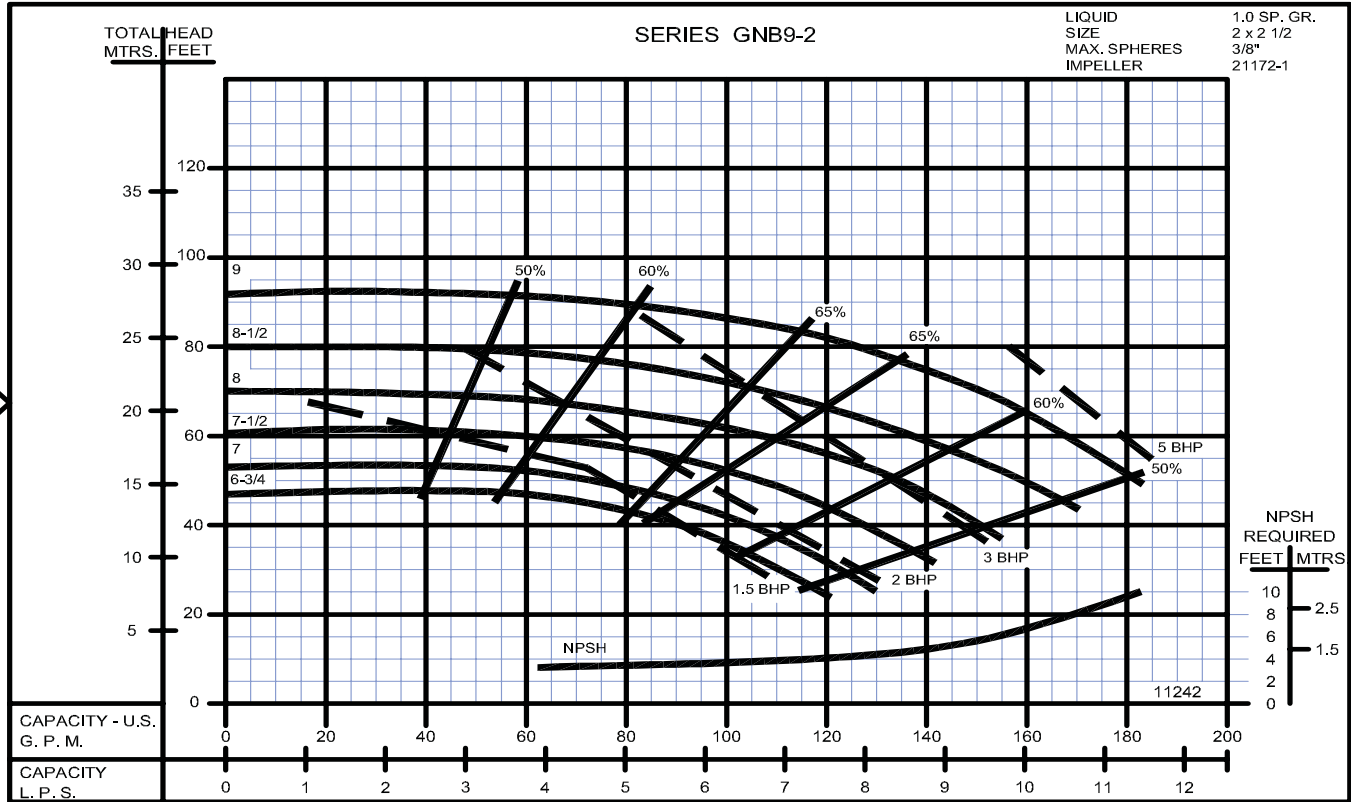

3500 RPM

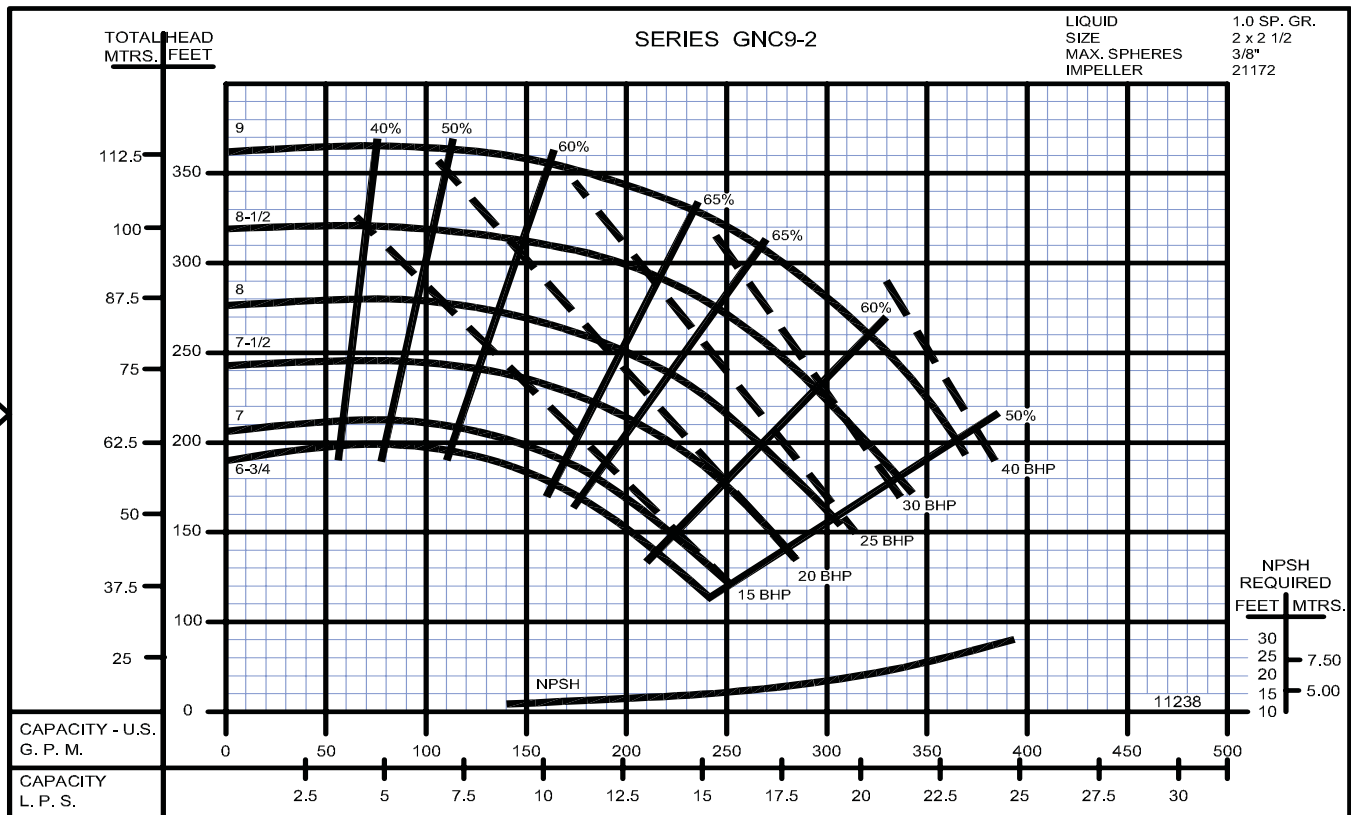

SECTION 3B
PAGE 18
DATE 1/06

CRANE[®]

PUMPS & SYSTEMS

A Crane Co. Company

USA: (937) 778-8947 • Canada: (905) 457-6223 • International: (937) 615-3598

Base Mounted Centrifugal Pumps

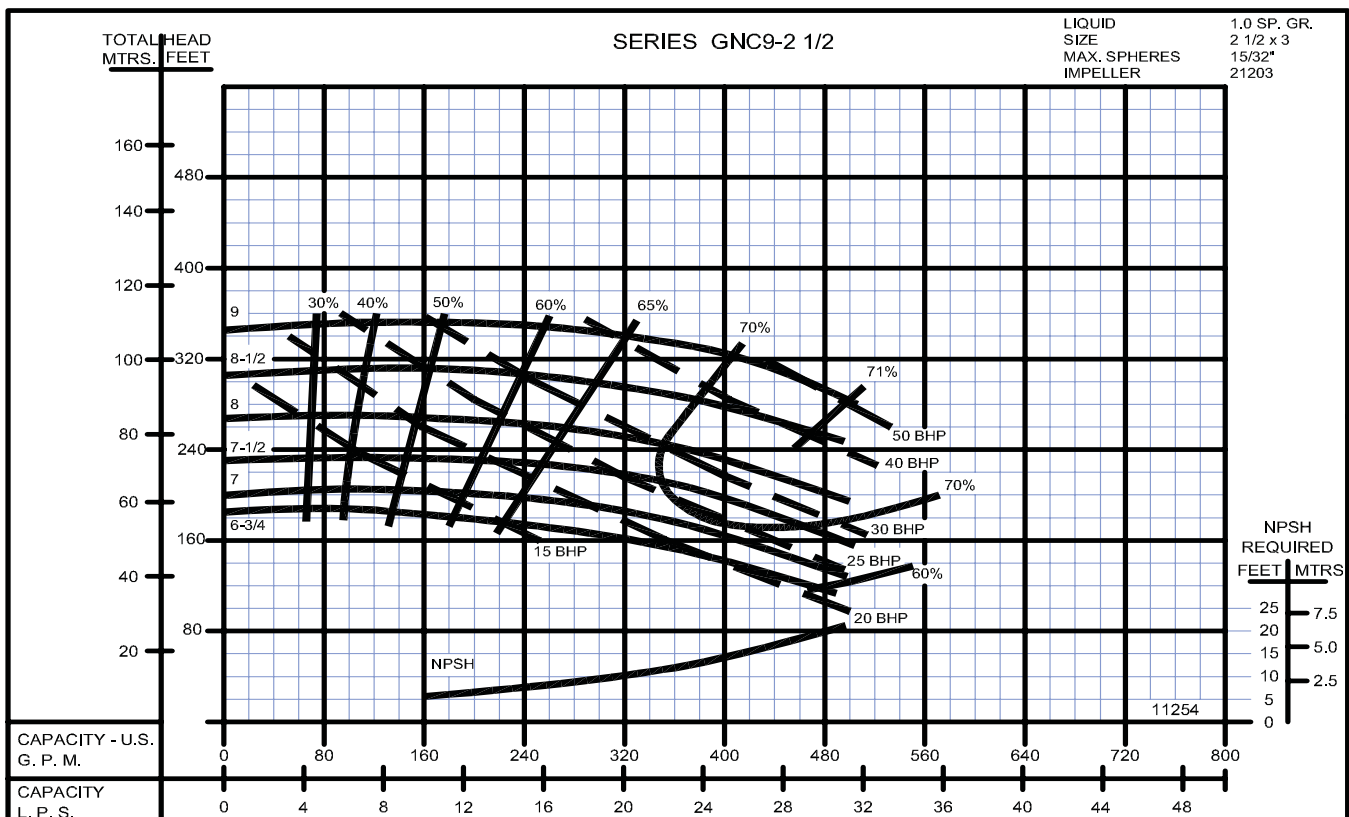
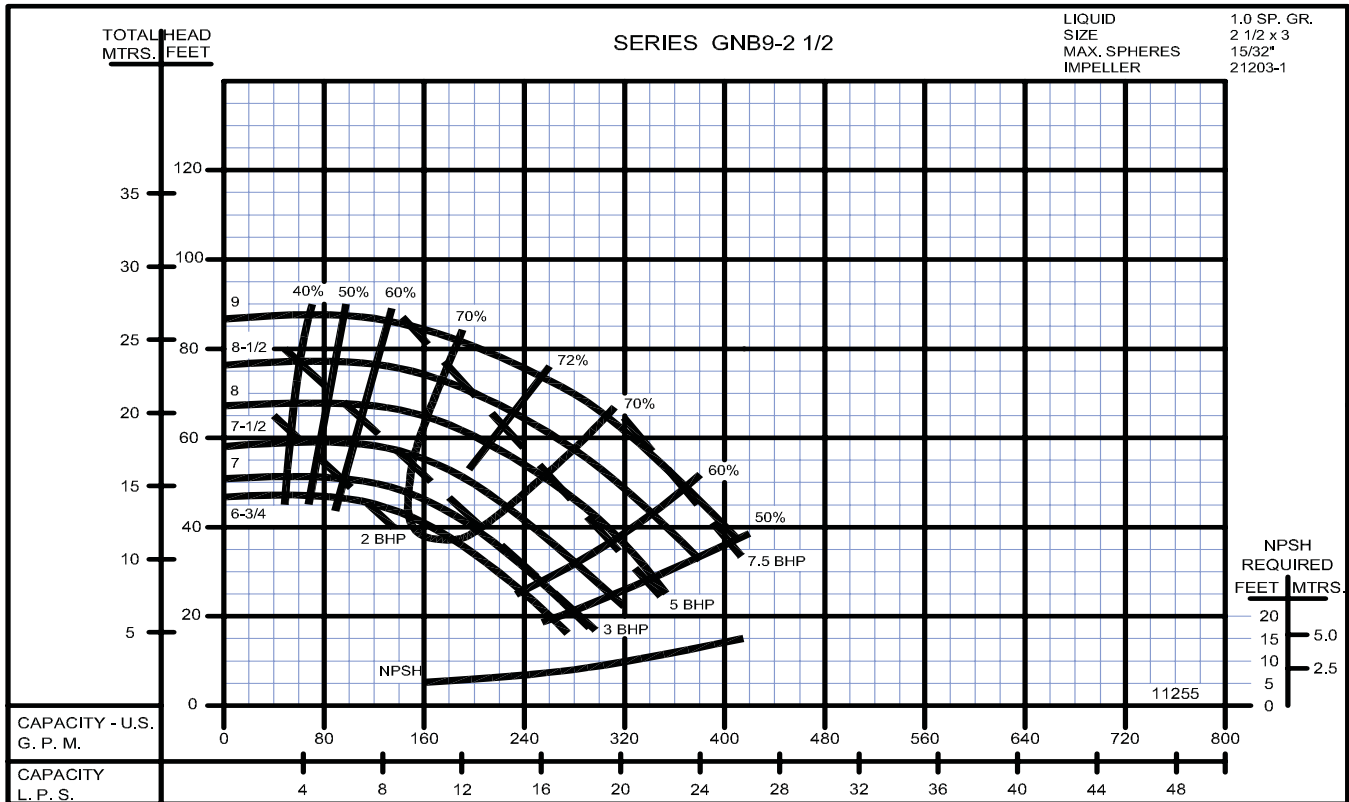

Base Mounted Centrifugal Pumps

1750 RPM

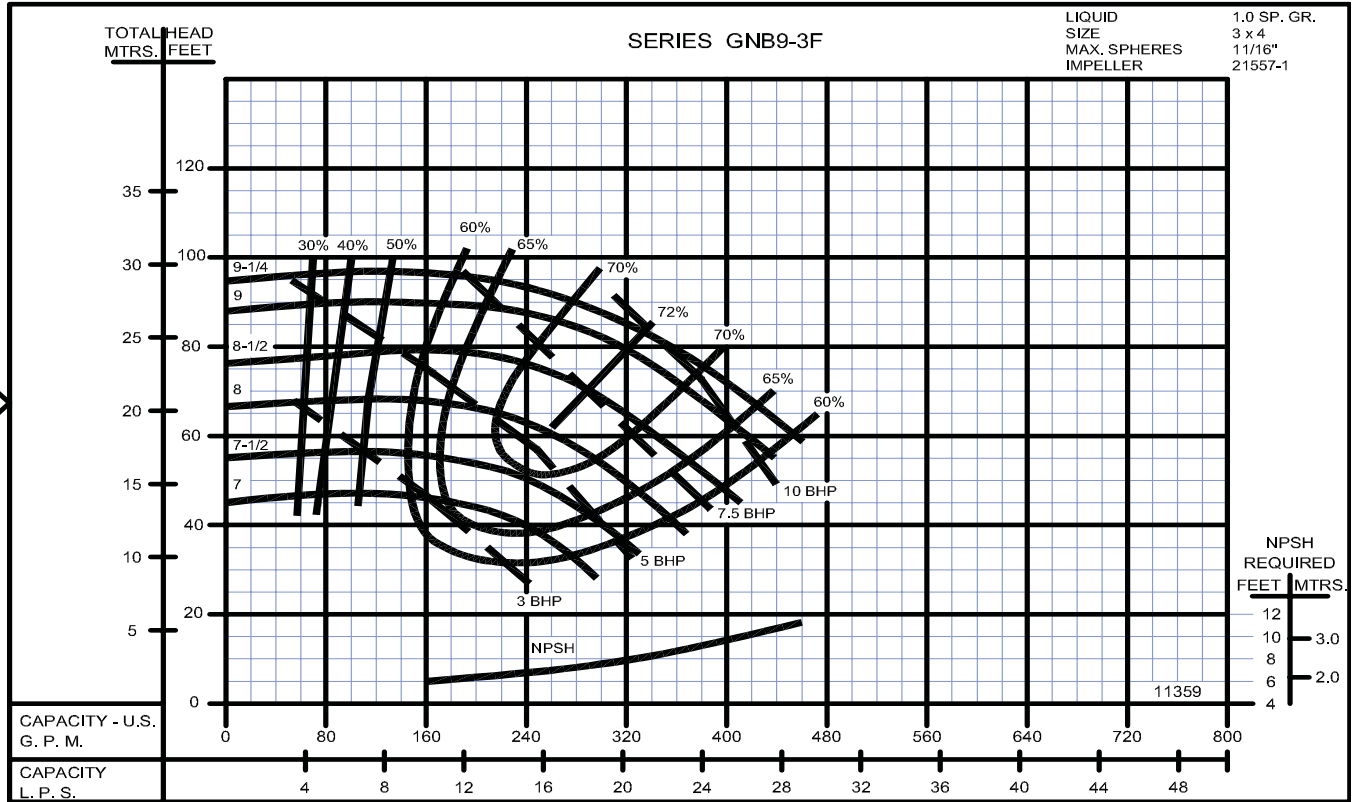

3500 RPM

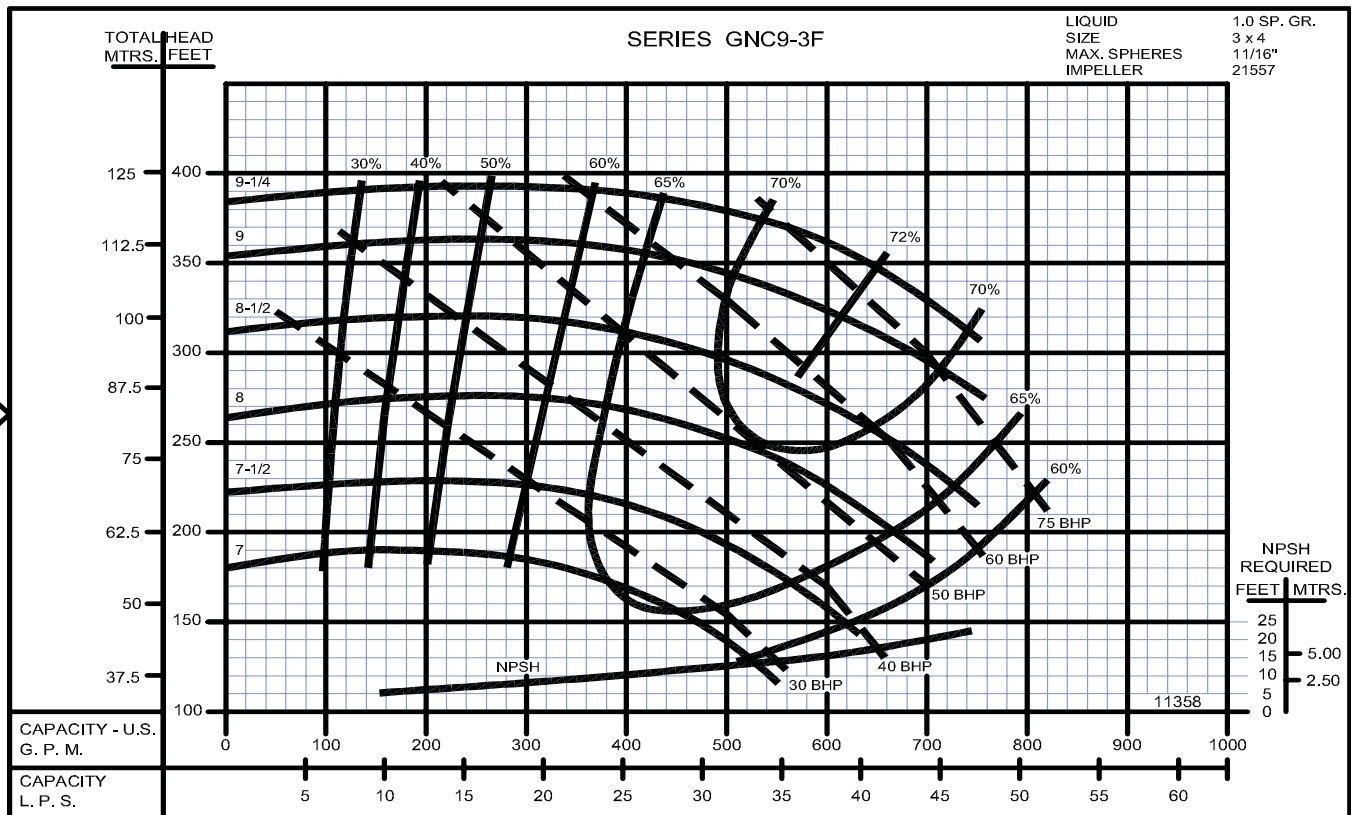

SECTION 3B
PAGE 20
DATE 1/06



PUMPS & SYSTEMS

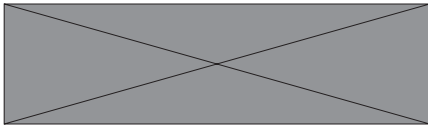

www.cranepumps.com

Series: GNB, GNC
60 Hz. Performance

Base Mounted Centrifugal Pumps

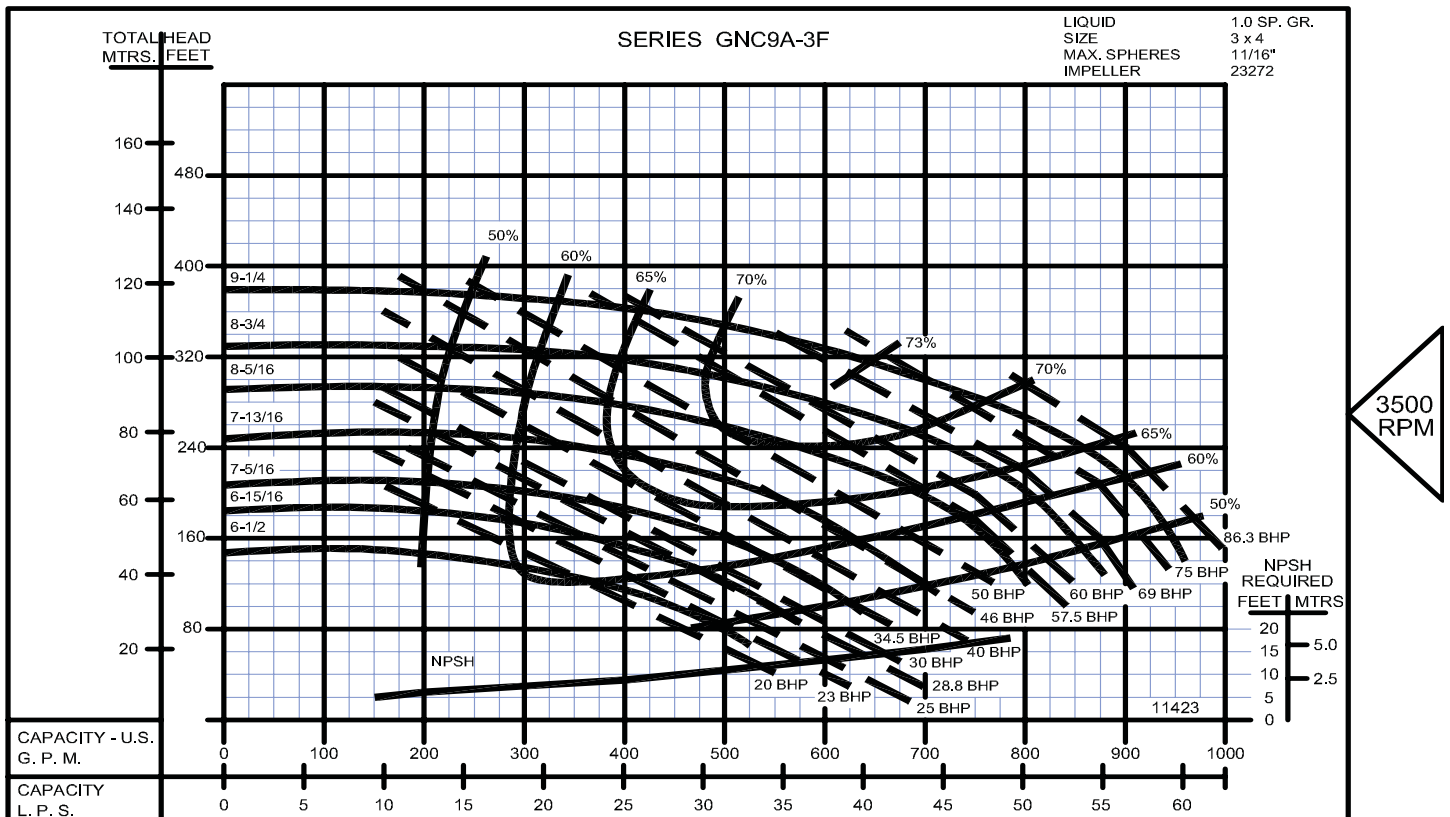
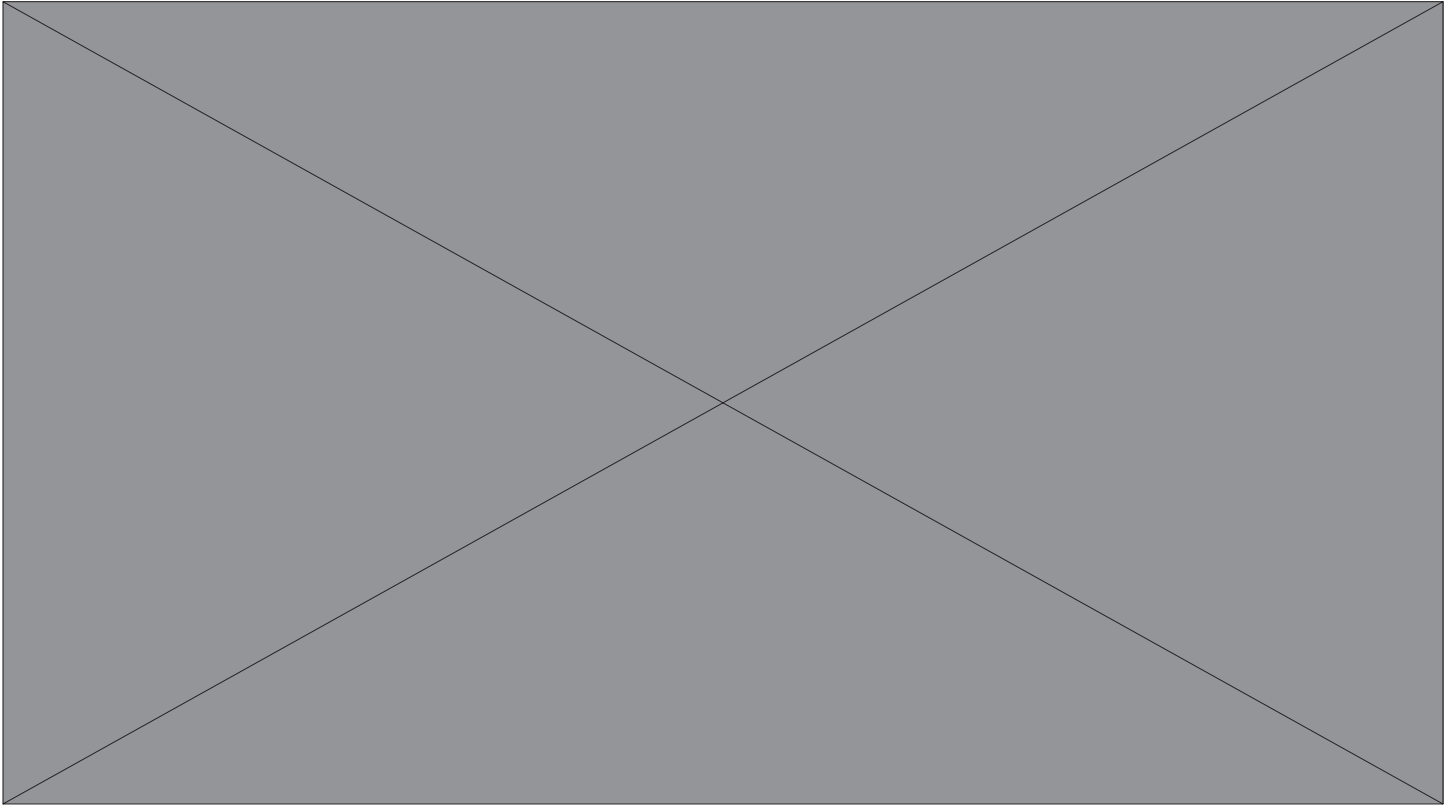

PUMPS & SYSTEMS

SECTION 3B
PAGE 21
DATE 2/09

A Crane Co. Company

USA: (937) 778-8947 • Canada: (905) 457-6223 • International: (937) 615-3598

Base Mounted Centrifugal Pumps

1450 RPM

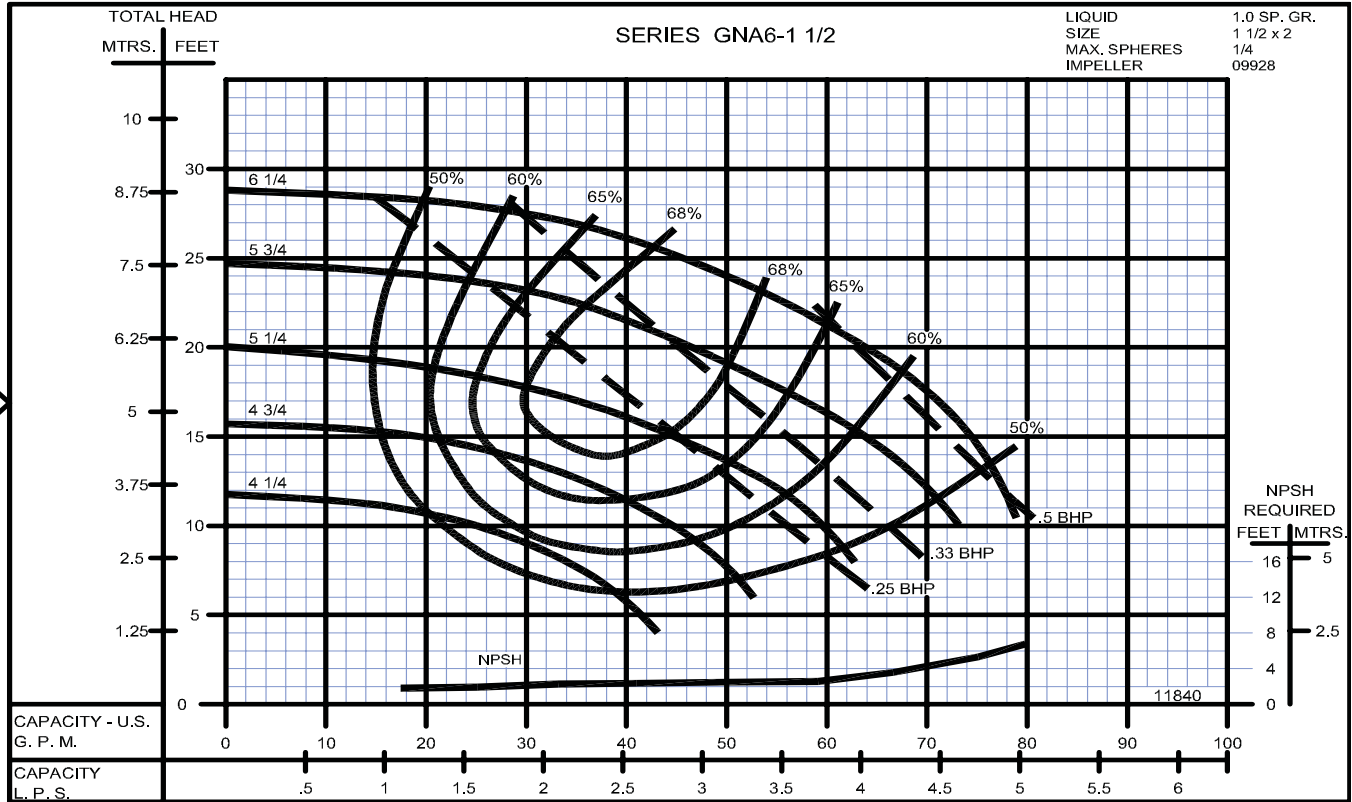

2900 RPM

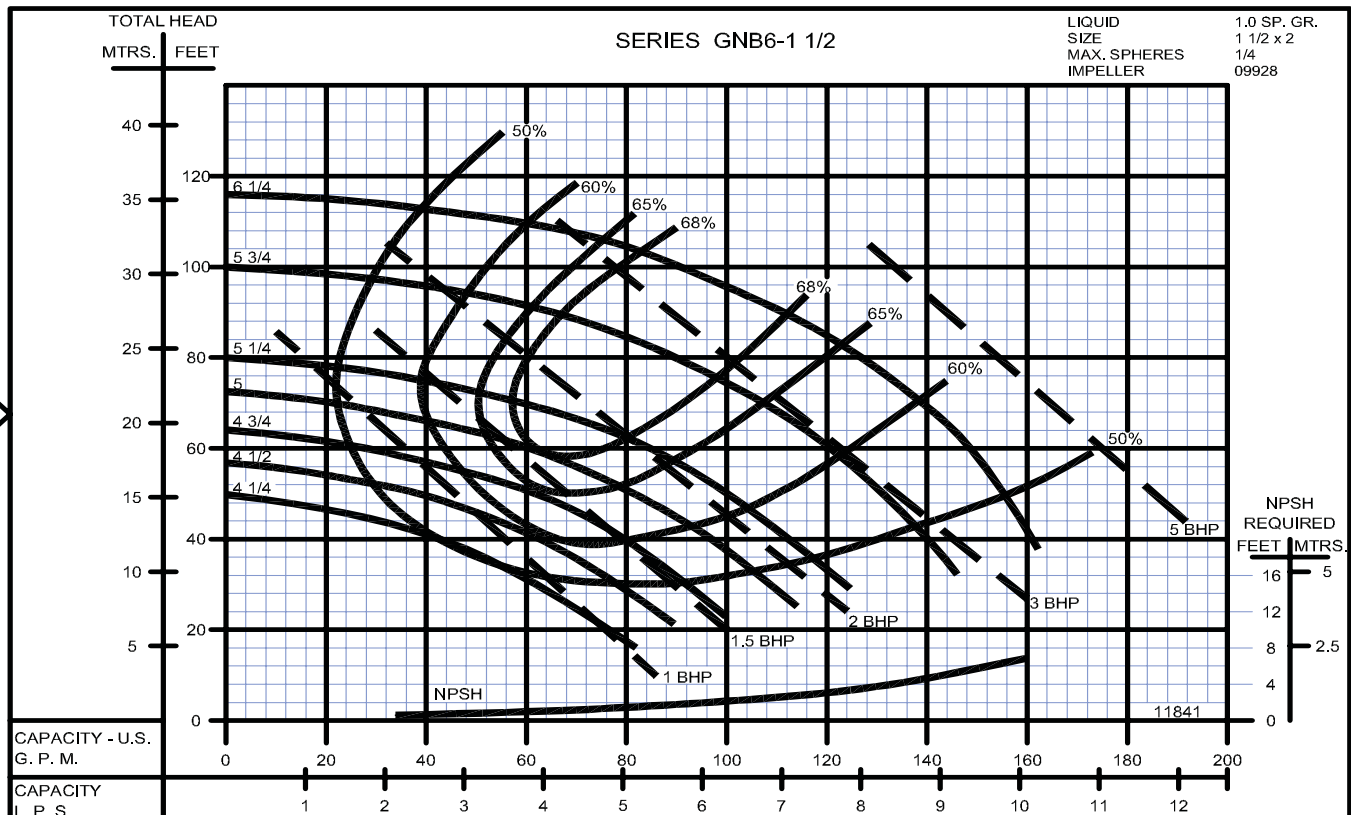

SECTION 3B
PAGE 22
DATE 1/06



PUMPS & SYSTEMS

A Crane Co. Company

USA: (937) 778-8947 • Canada: (905) 457-6223 • International: (937) 615-3598

Base Mounted Centrifugal Pumps

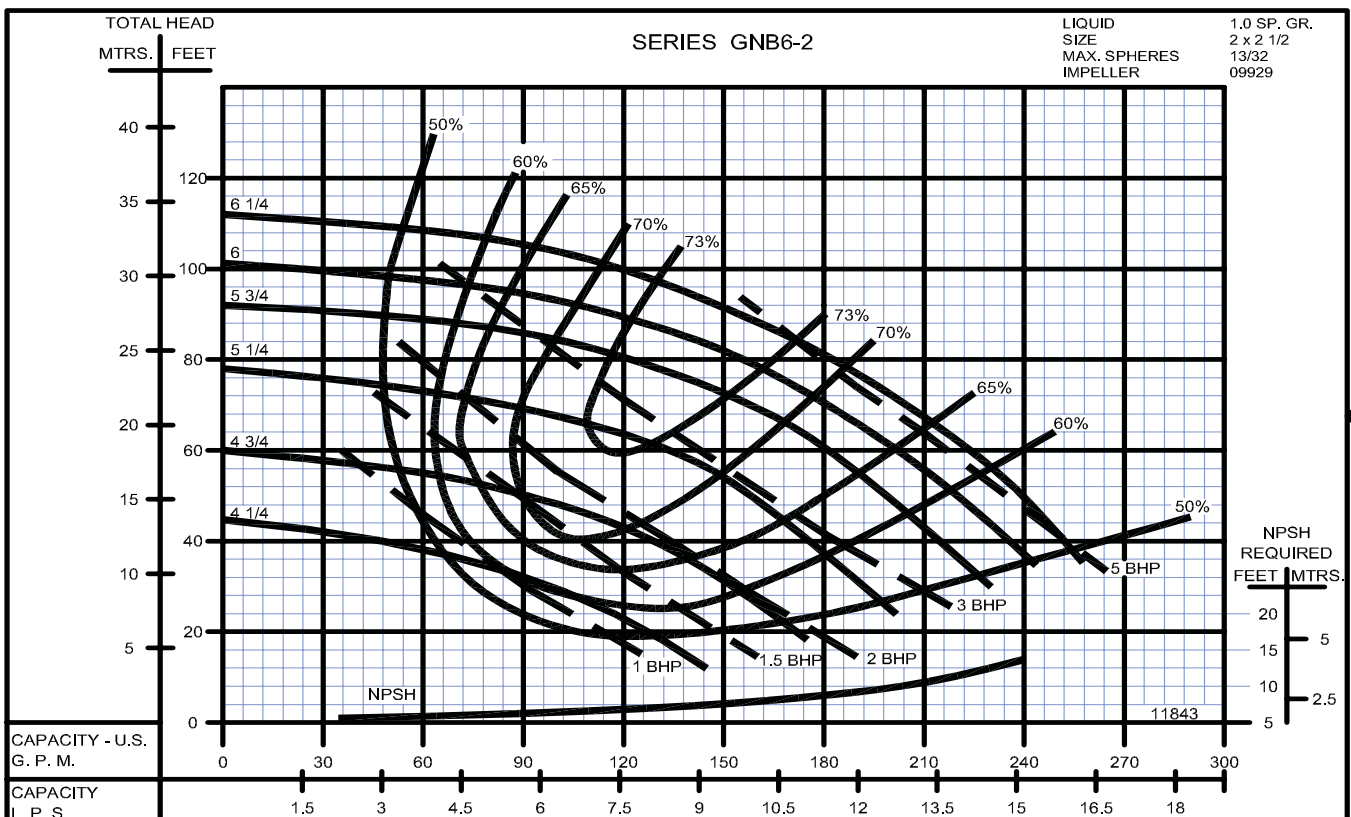
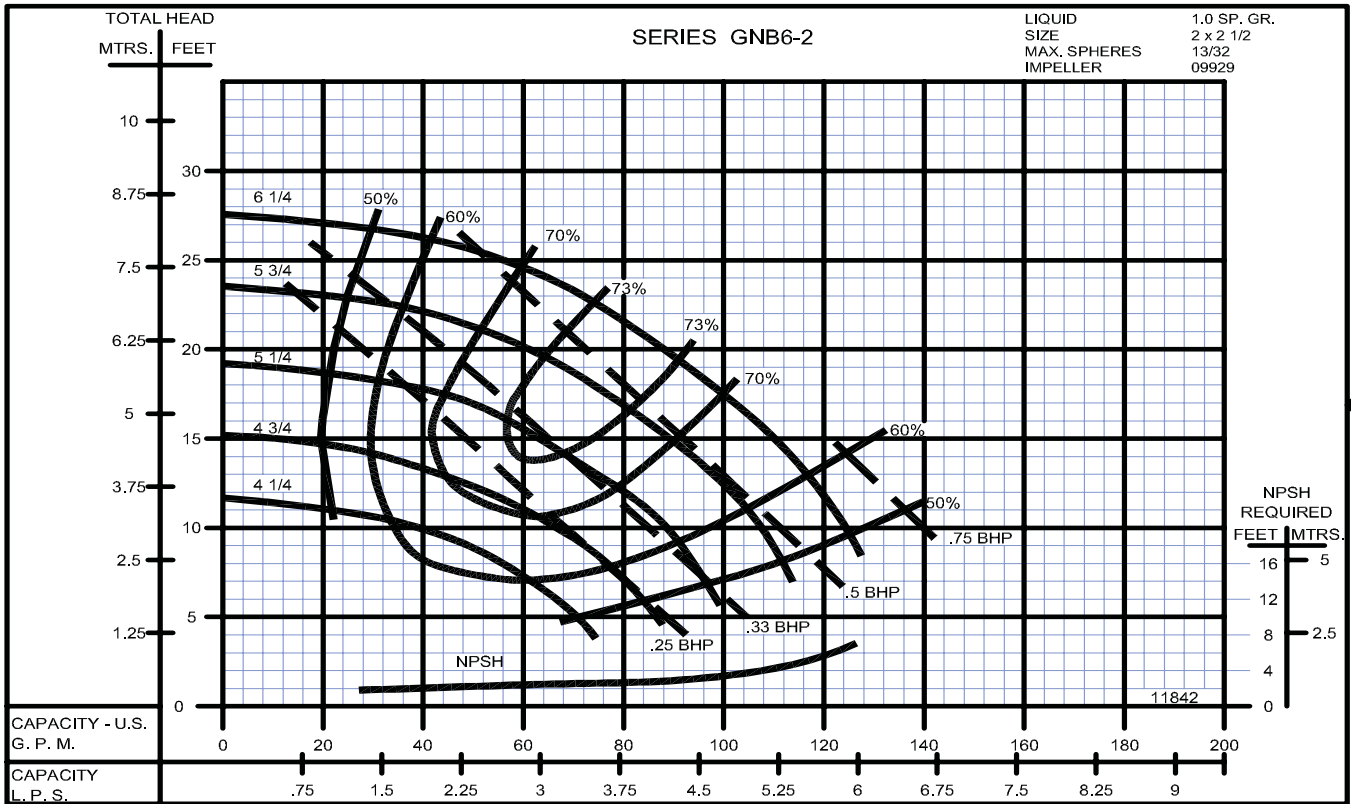

Base Mounted Centrifugal Pumps

1450
RPM

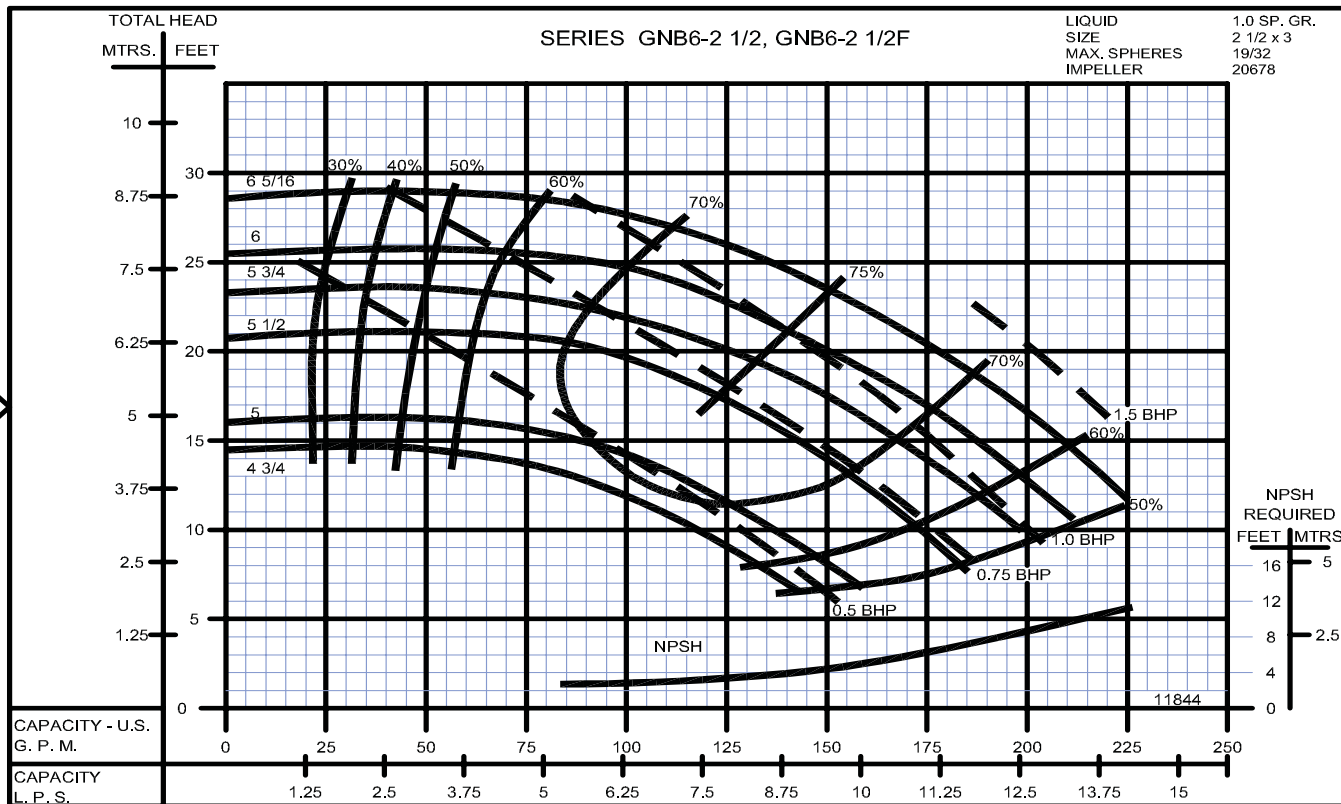

2900
RPM

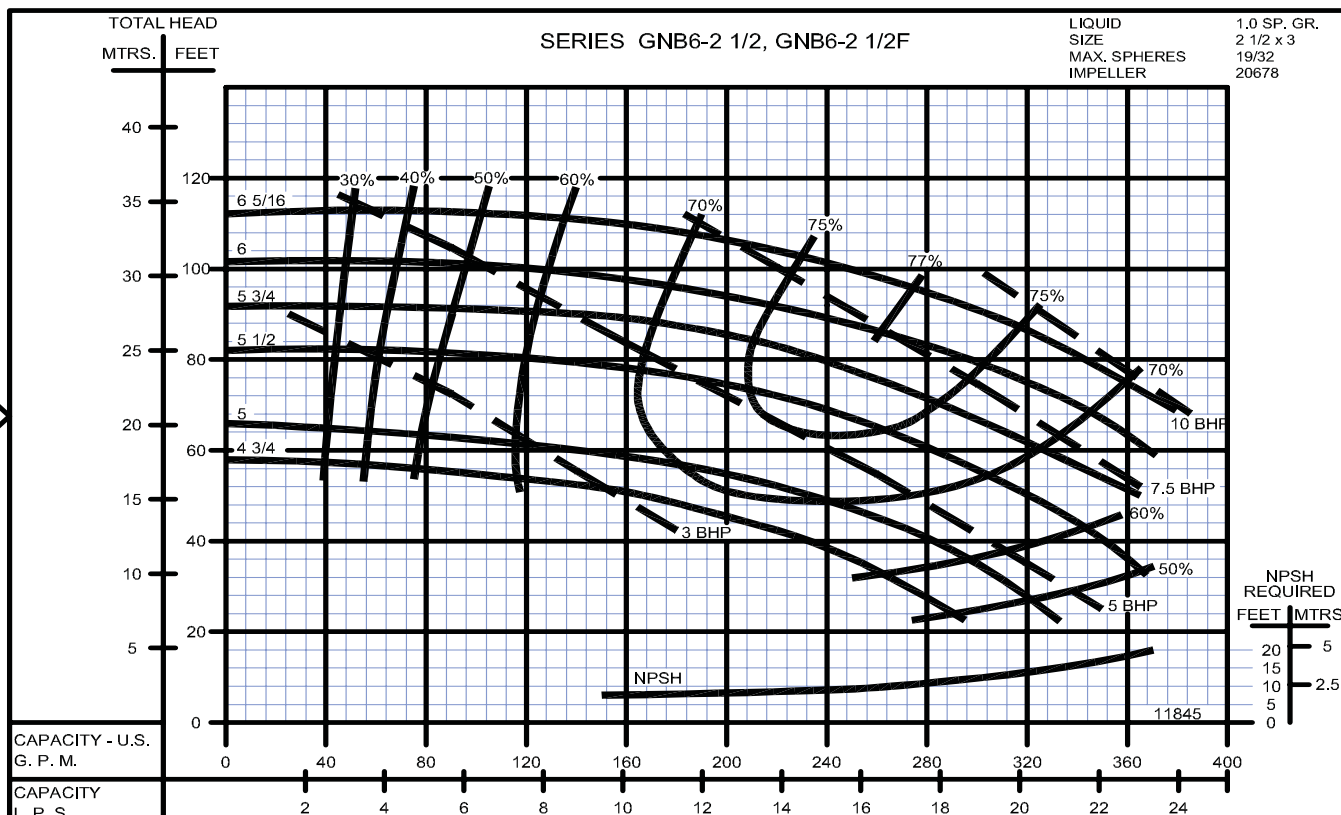

SECTION 3B
PAGE 24
DATE 1/06



PUMPS & SYSTEMS

A Crane Co. Company

USA: (937) 778-8947 • Canada: (905) 457-6223 • International: (937) 615-3598

Base Mounted Centrifugal Pumps

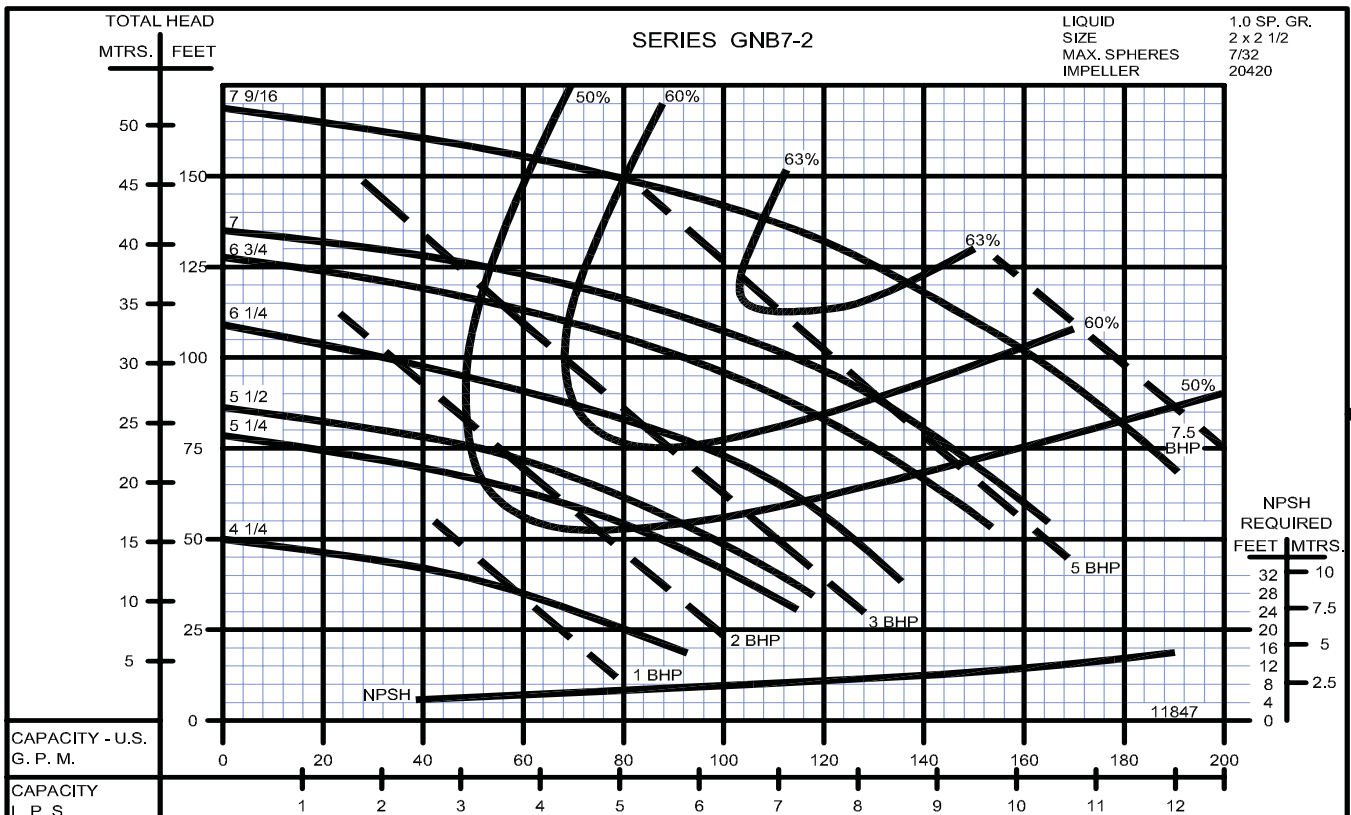
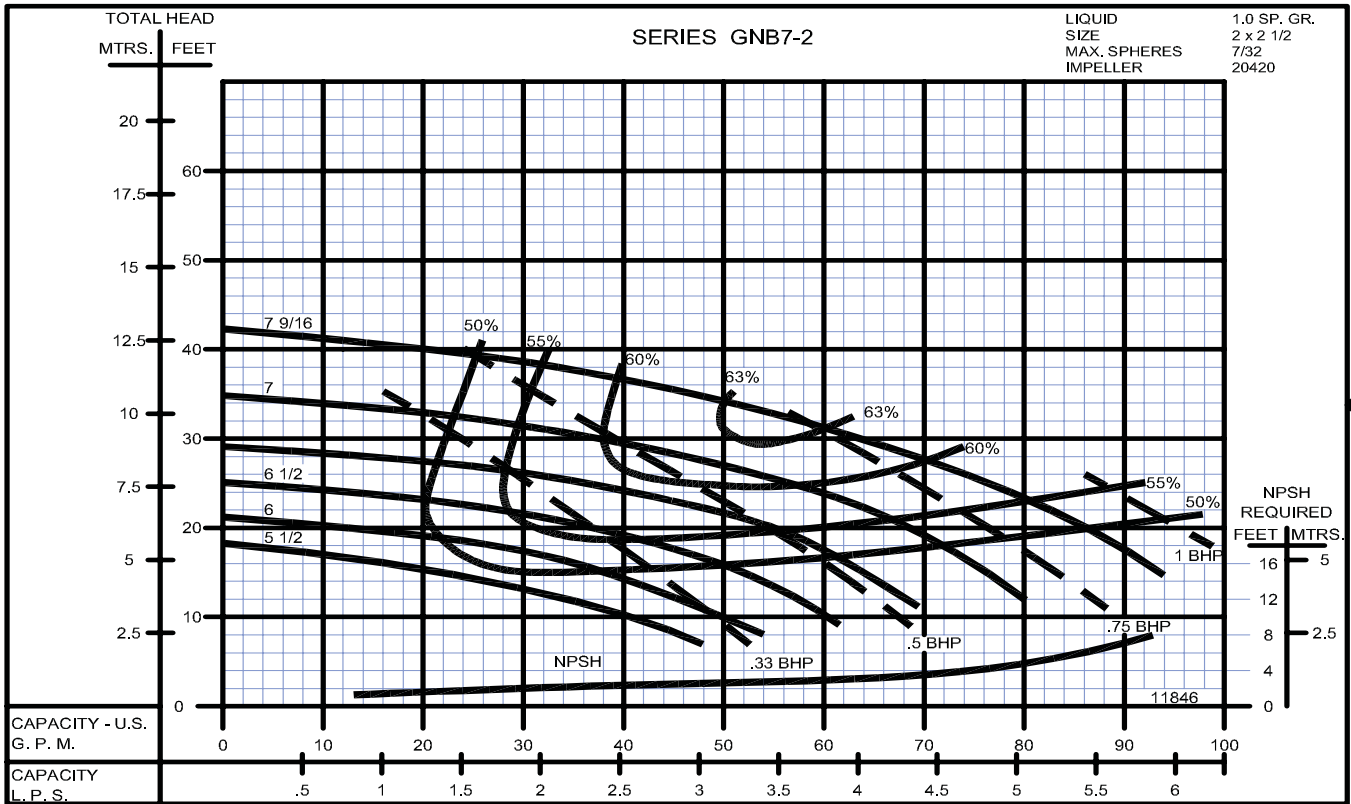

Base Mounted Centrifugal Pumps

1450
RPM

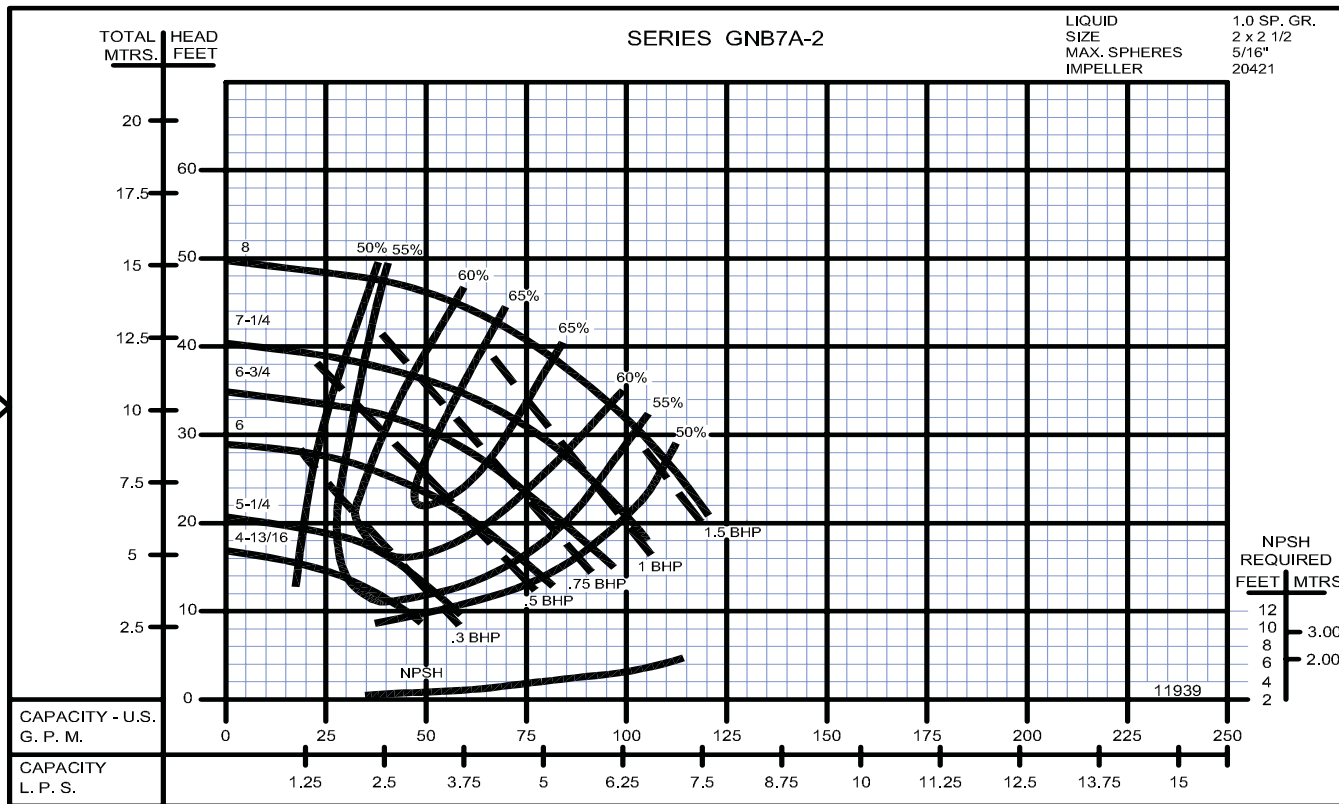

2900
RPM

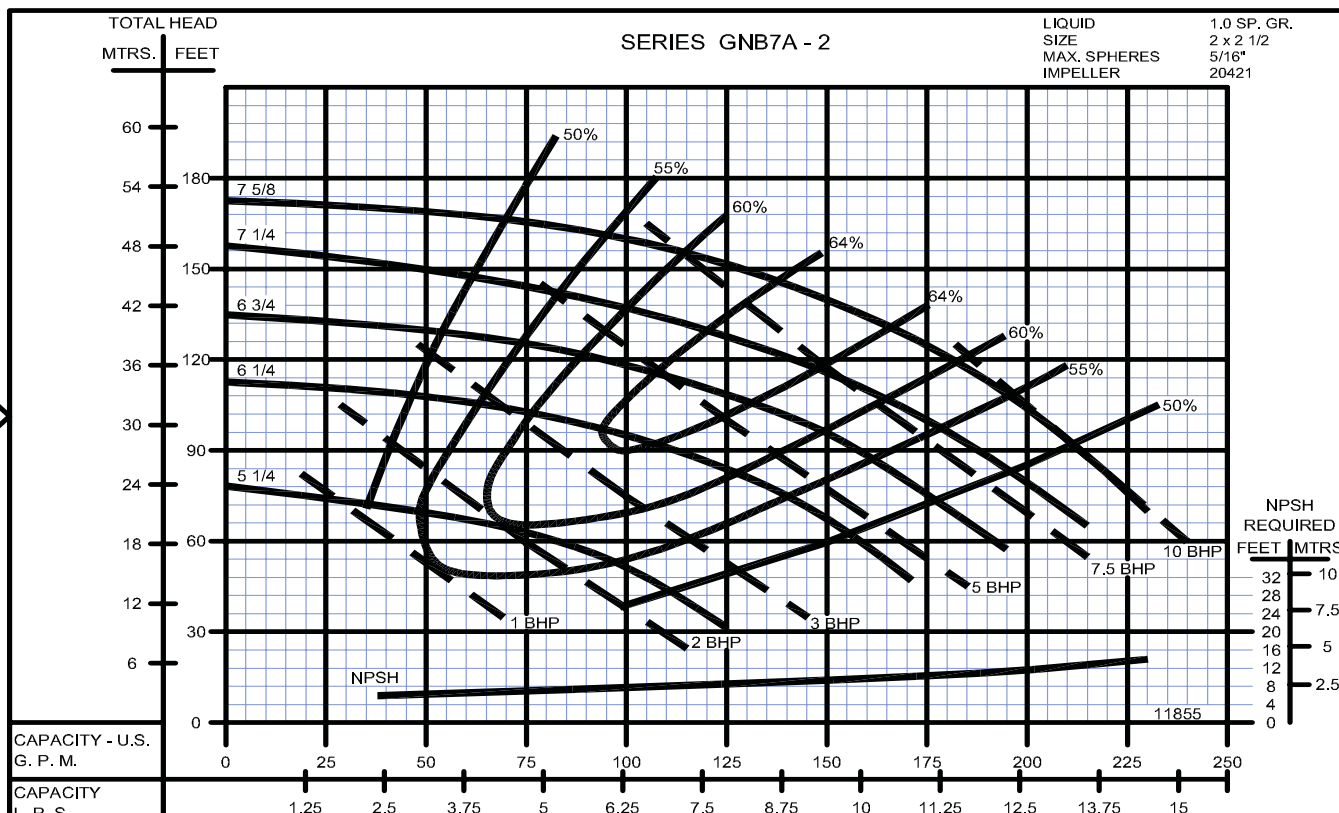

Base Mounted Centrifugal Pumps

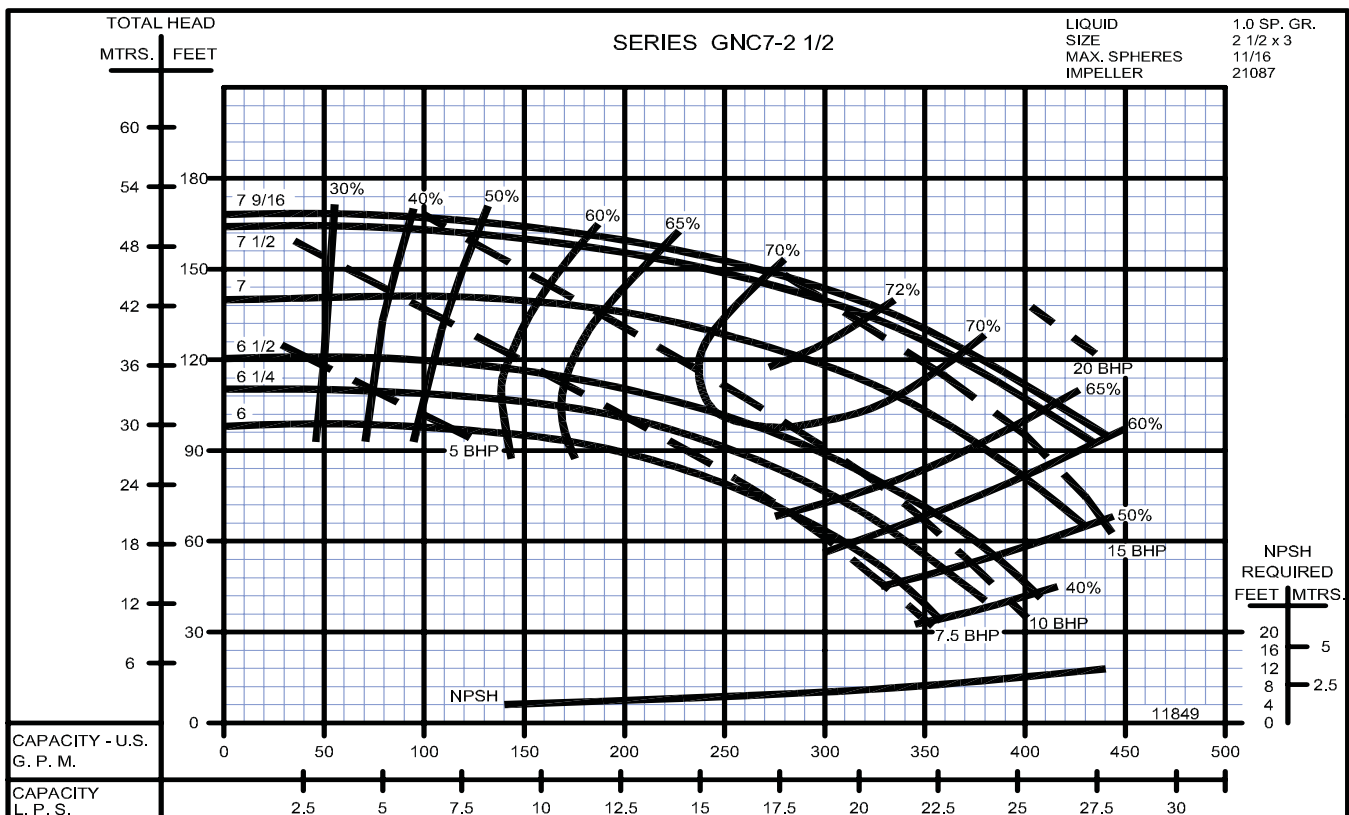
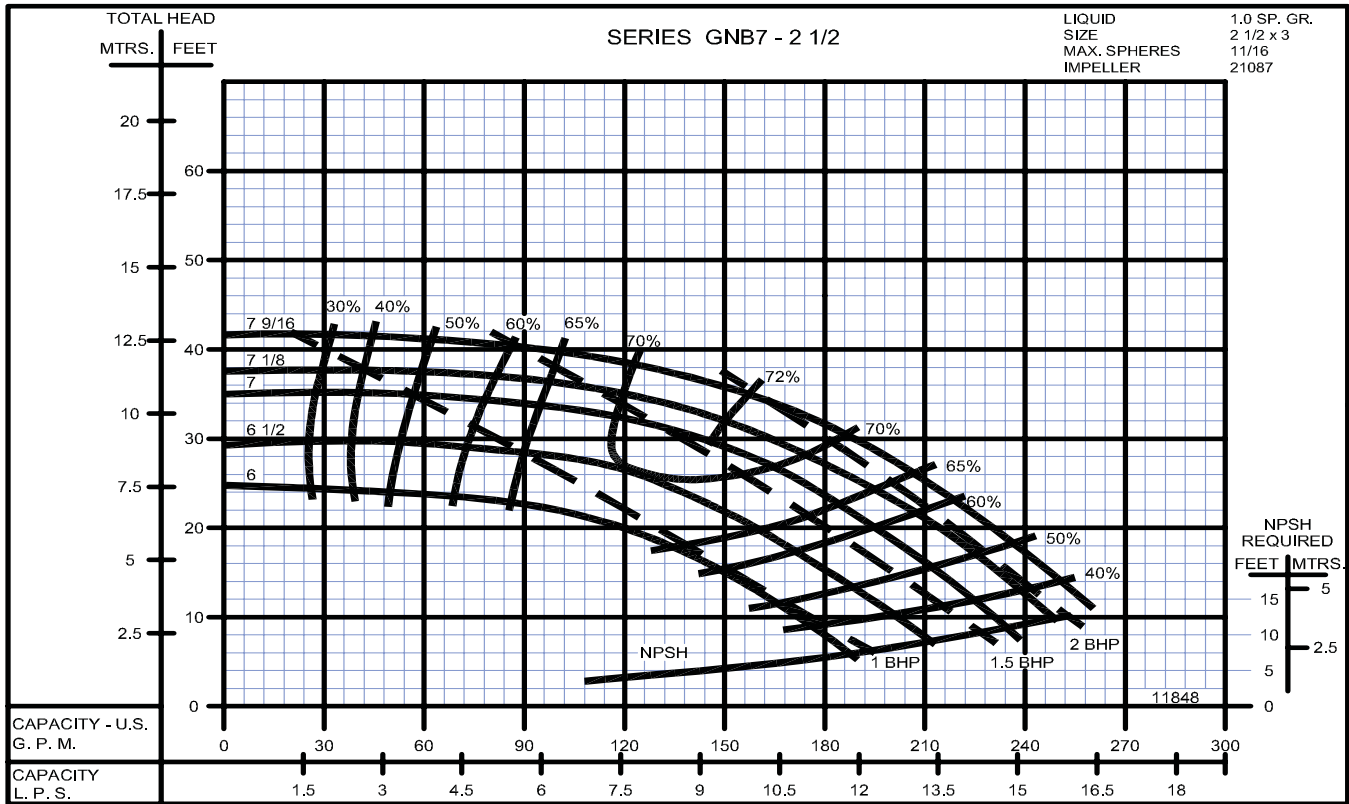

Base Mounted Centrifugal Pumps

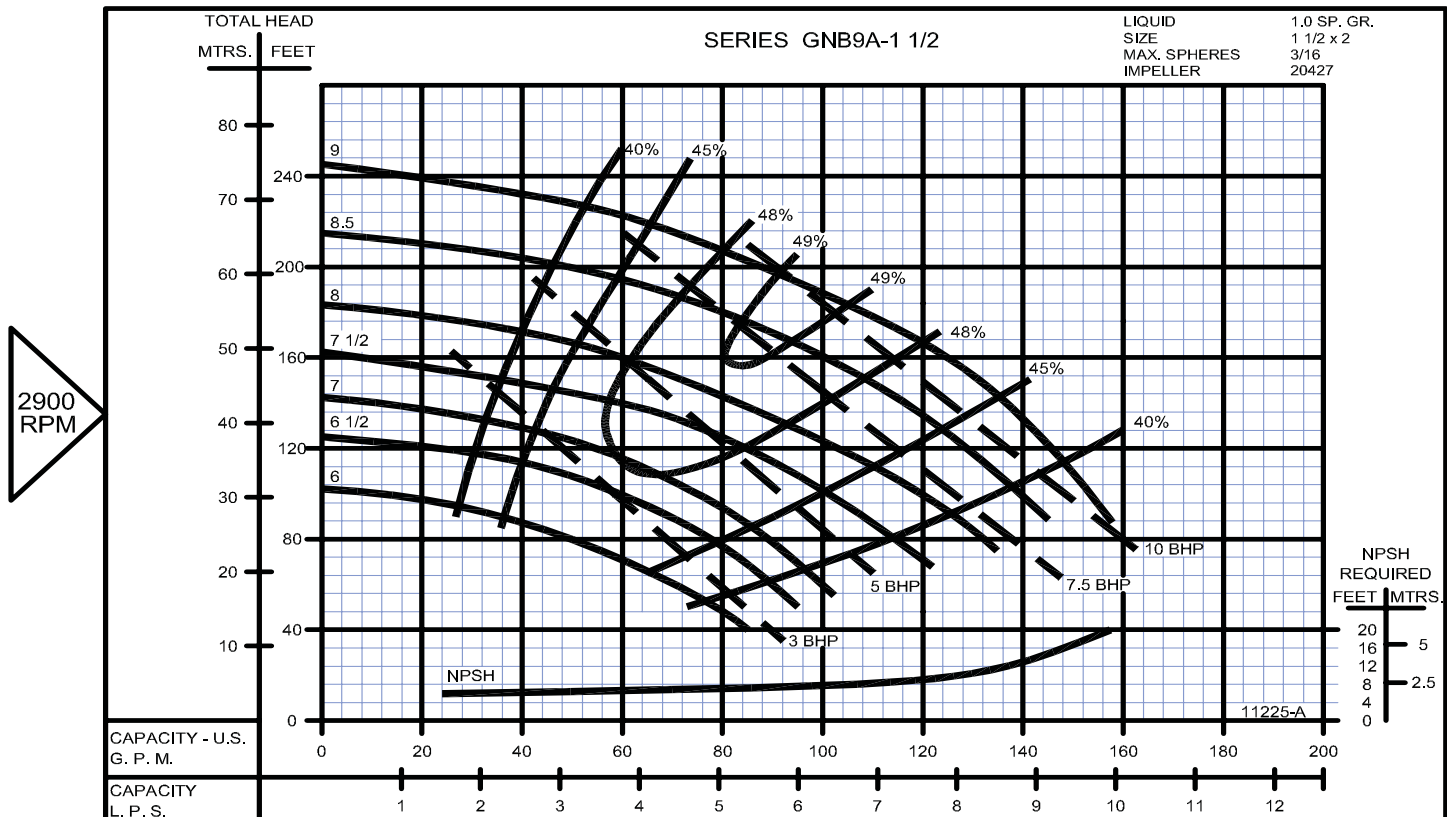
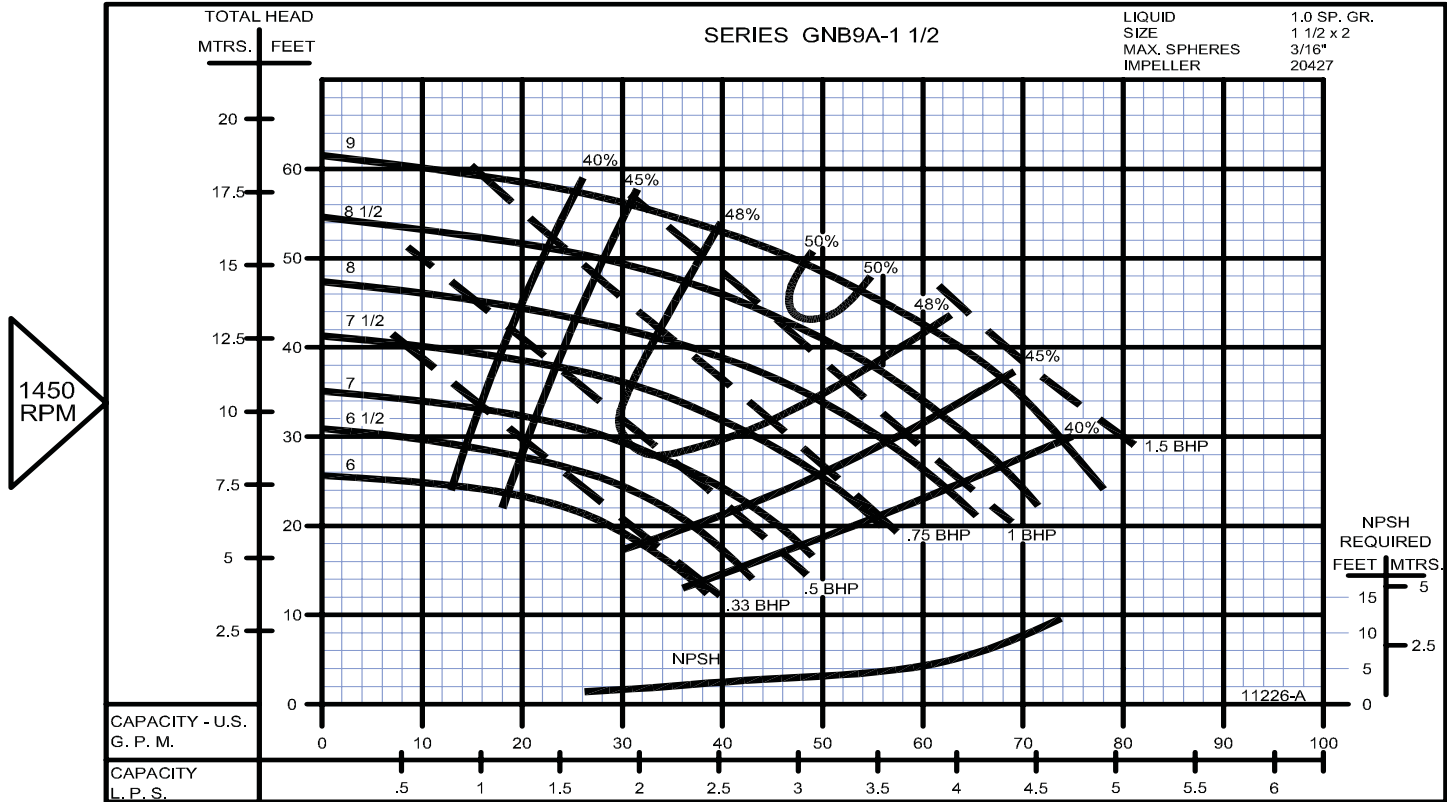

SECTION 3B
PAGE 28
DATE 1/06

CRANE[®]

A Crane Co. Company

PUMPS & SYSTEMS

USA: (937) 778-8947 • Canada: (905) 457-6223 • International: (937) 615-3598

Base Mounted Centrifugal Pumps

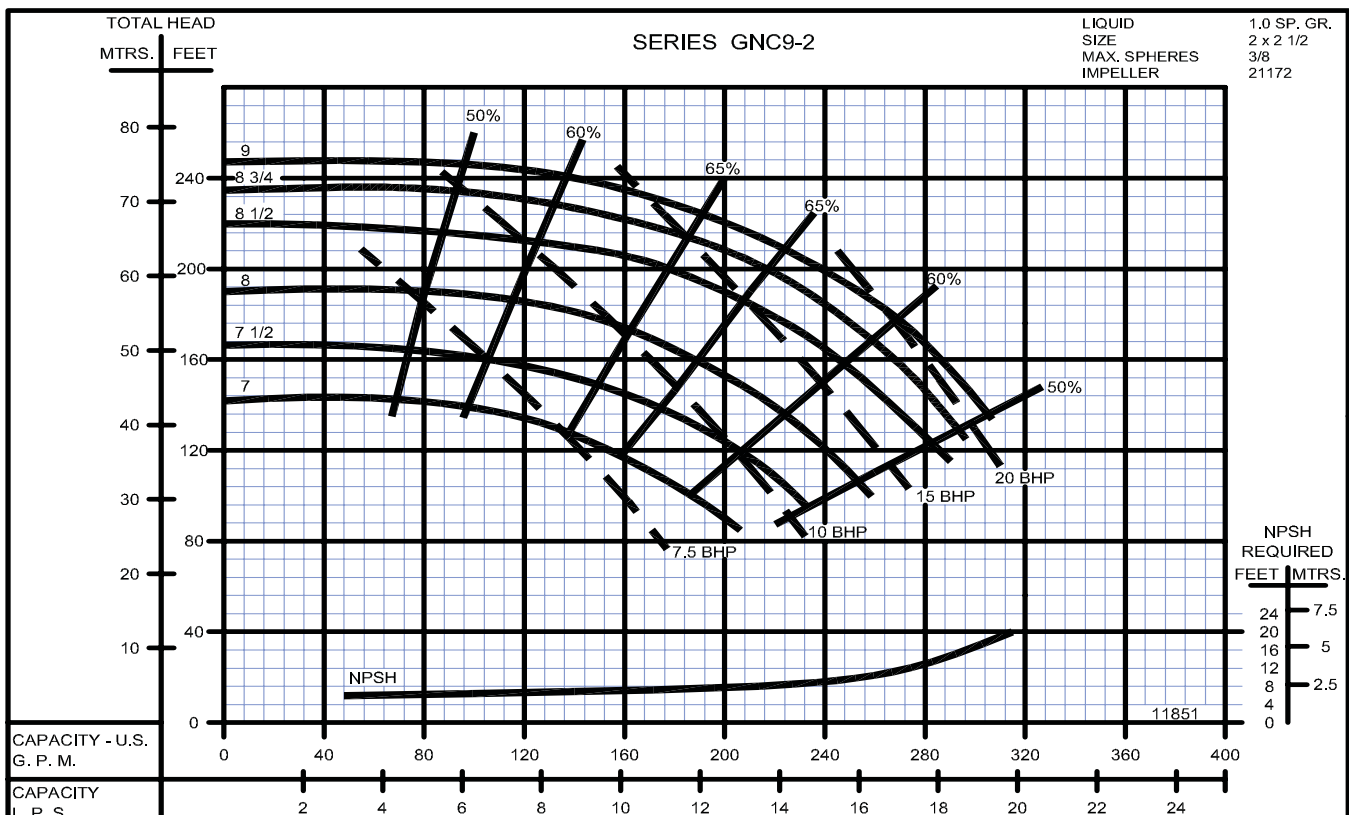
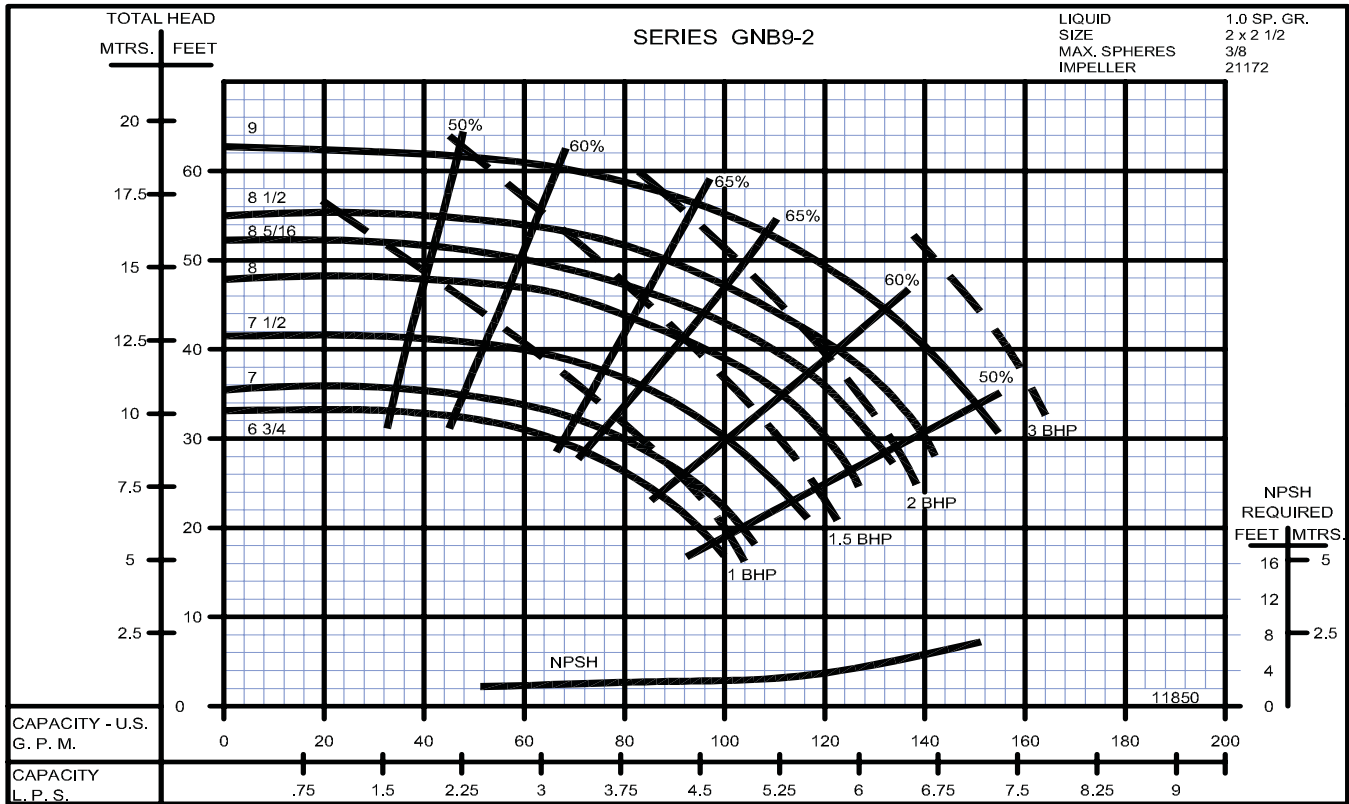

Base Mounted Centrifugal Pumps

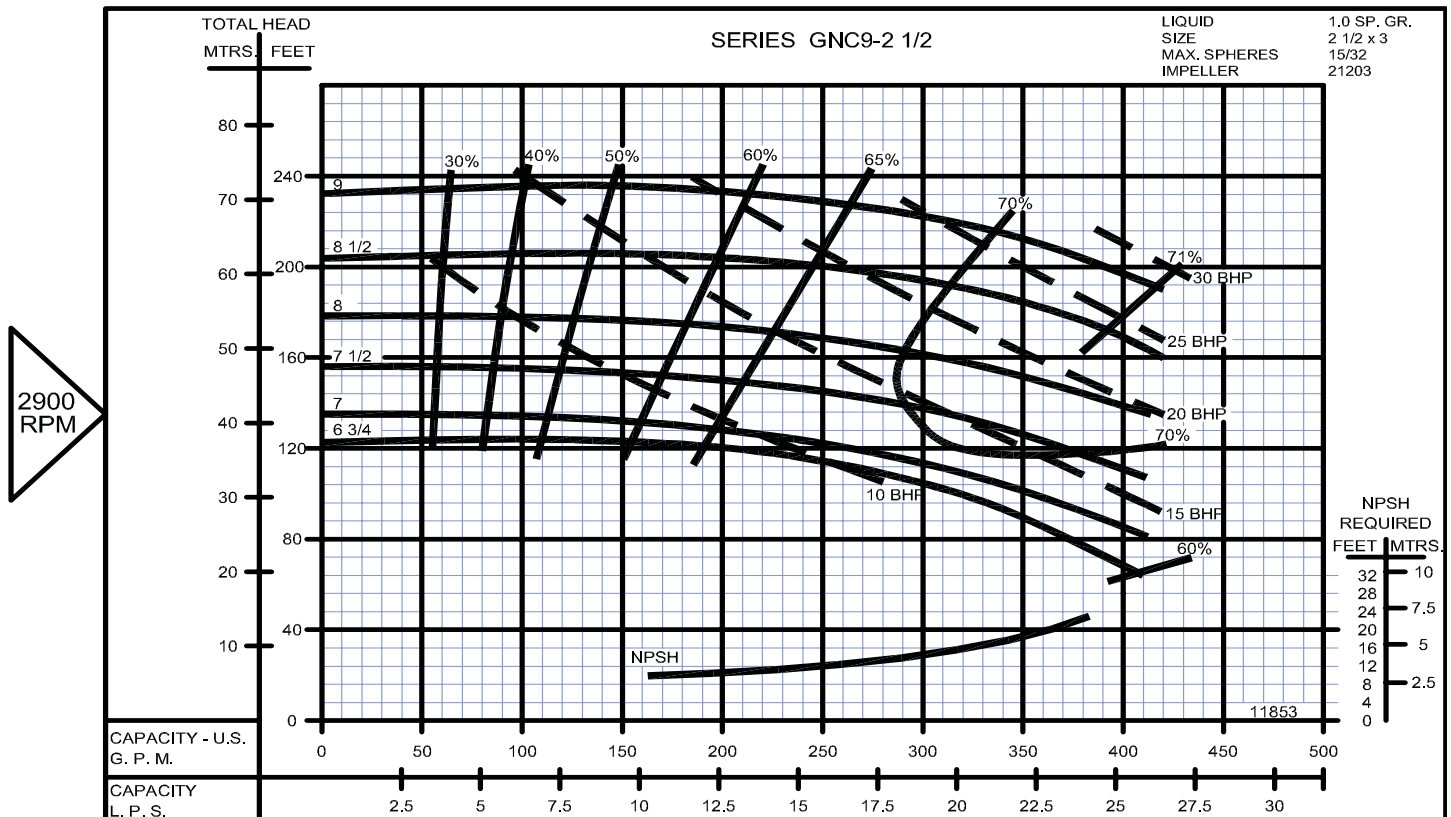
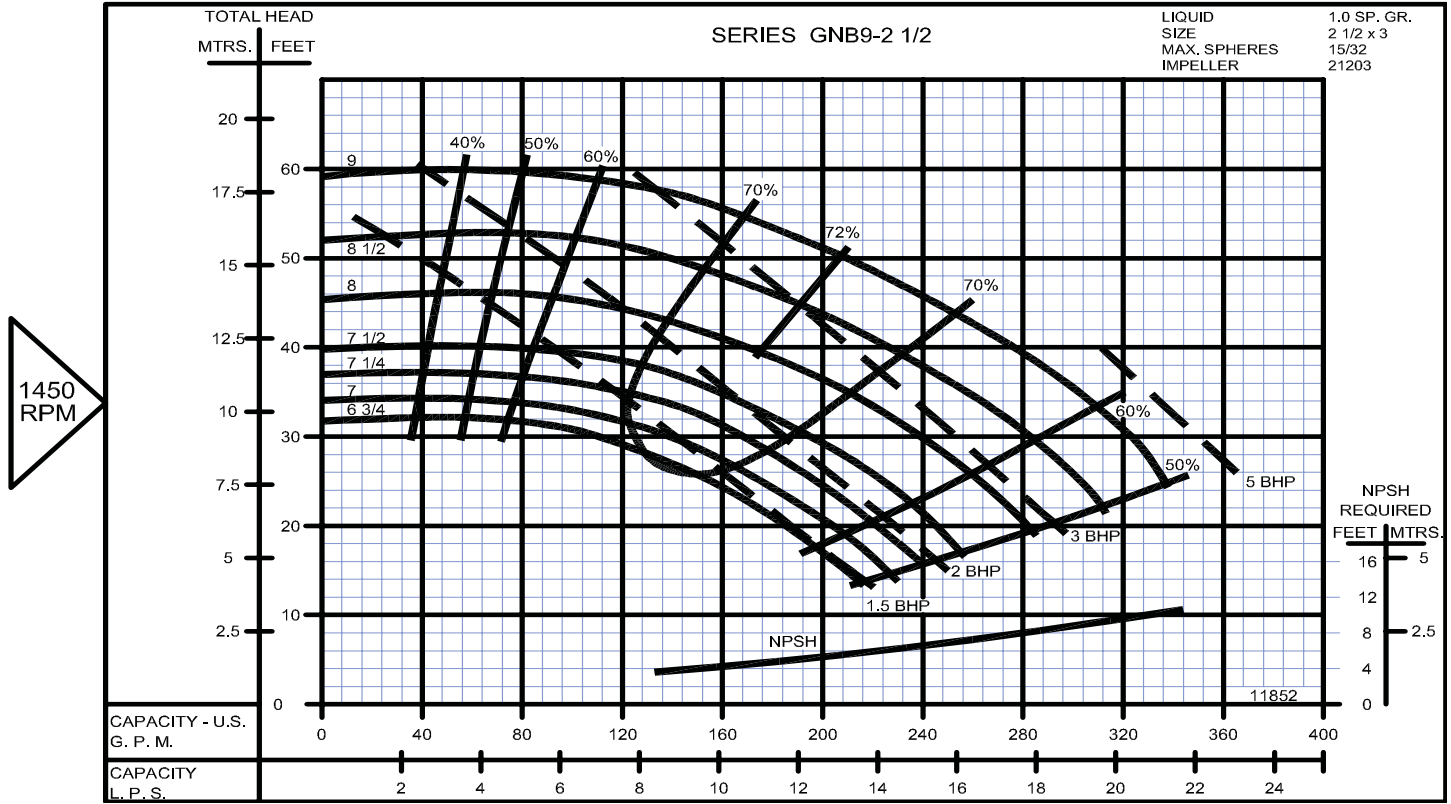

SECTION 3B
PAGE 30
DATE 1/06



A Crane Co. Company

PUMPS & SYSTEMS

Base Mounted Centrifugal Pumps

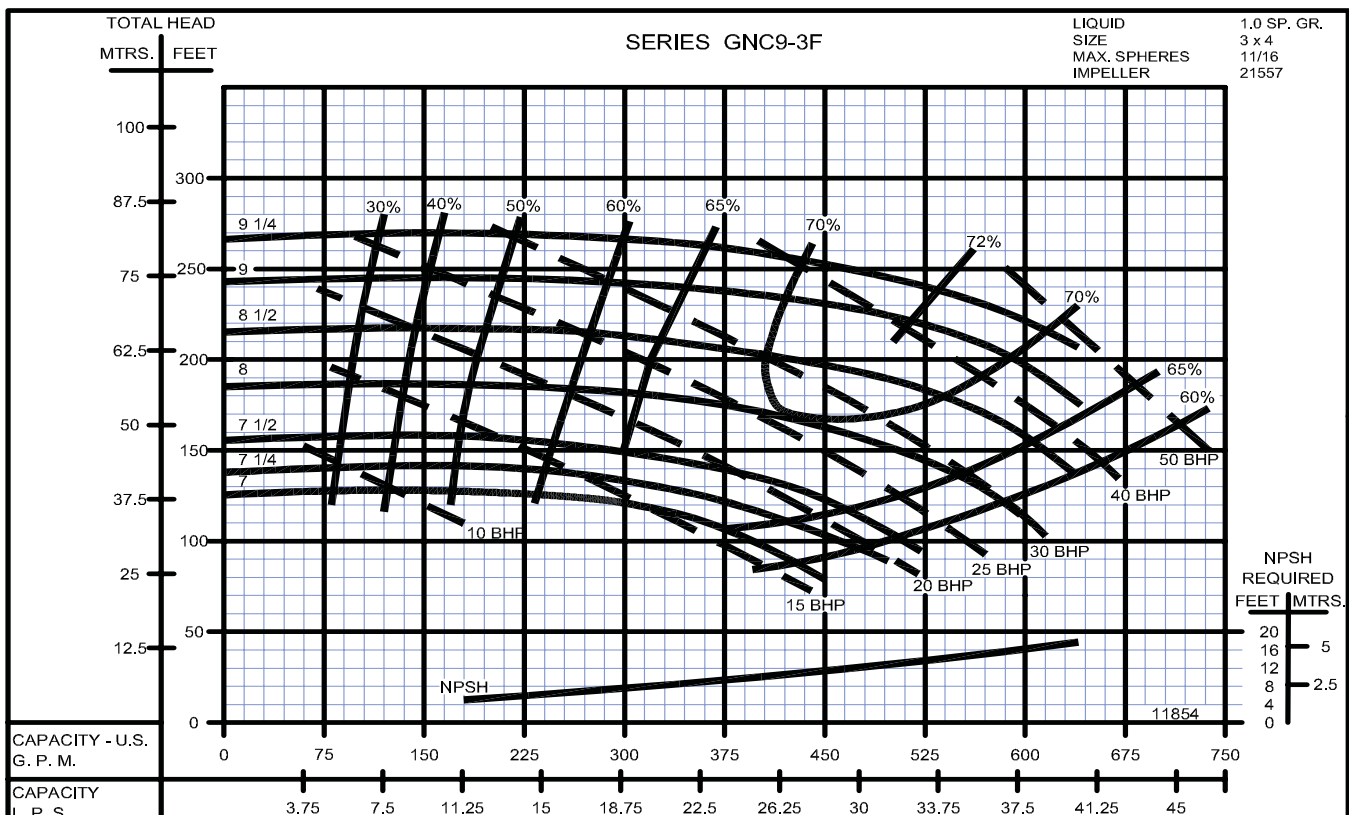
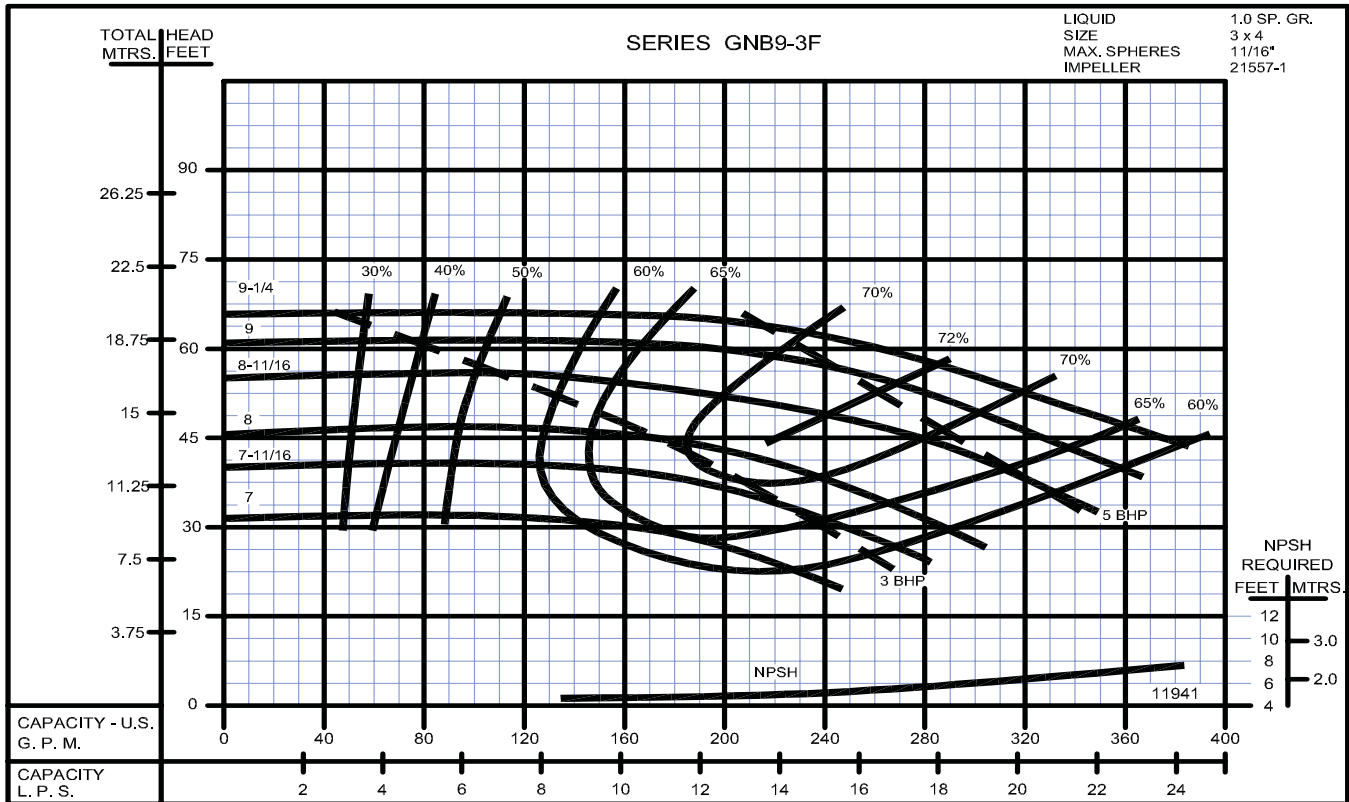

Base Mounted Centrifugal Pumps

1450 RPM

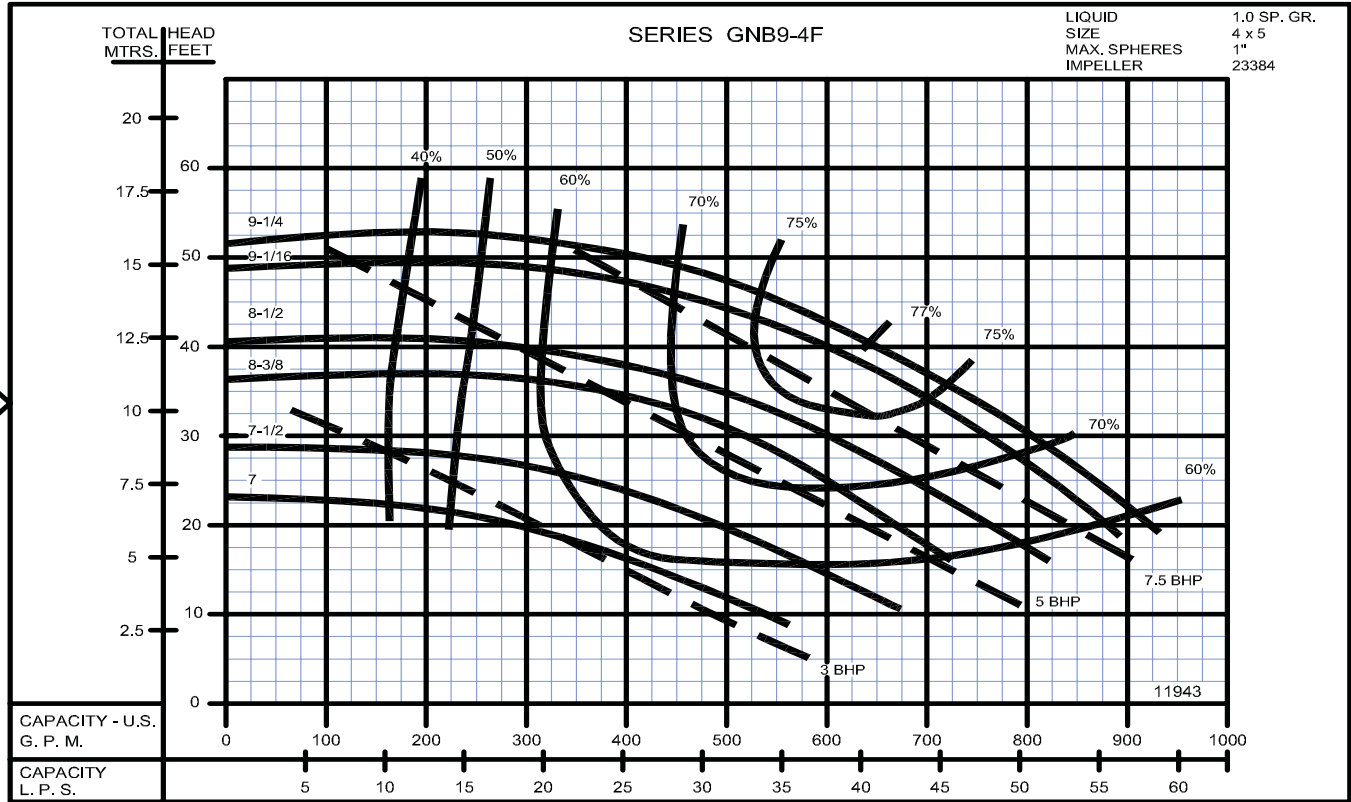

2900 RPM

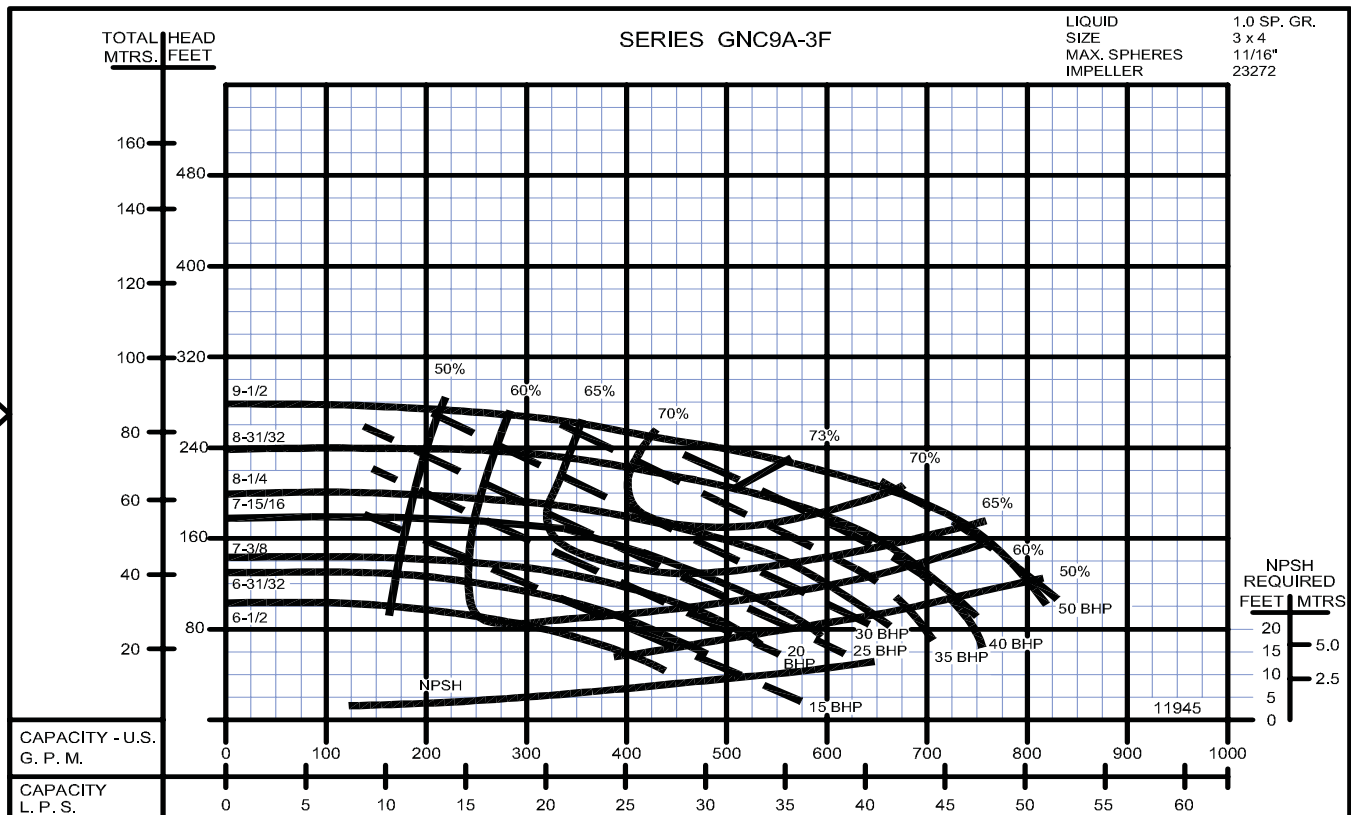

SECTION 3B
PAGE 32
DATE 1/06



PUMPS & SYSTEMS

A Crane Co. Company

USA: (937) 778-8947 • Canada: (905) 457-6223 • International: (937) 615-3598