

SECTION	2C
PAGE	7
ISSUED	2/03
REPLACES	12/01

**CLOSE COUPLED CENTRIFUGAL PUMPS**

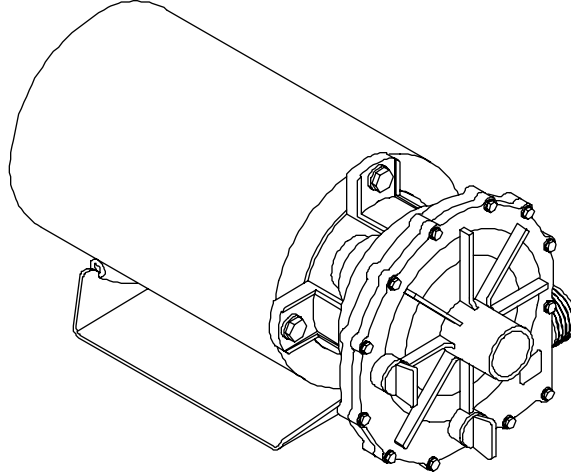

**3500RPM - 60Hz.**  
 CAPACITIES TO 70GPM (4.4LPS)  
 HEADS TO 56 FEET (17.1M)

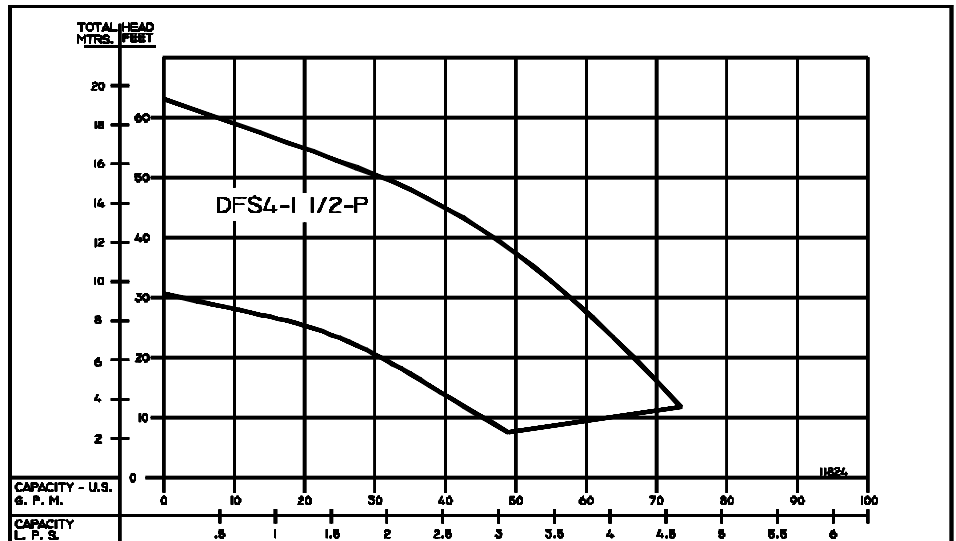

**2900RPM - 50Hz.**  
 CAPACITIES TO 60GPM (3.8LPS)  
 HEADS TO 43 FEET (13M)

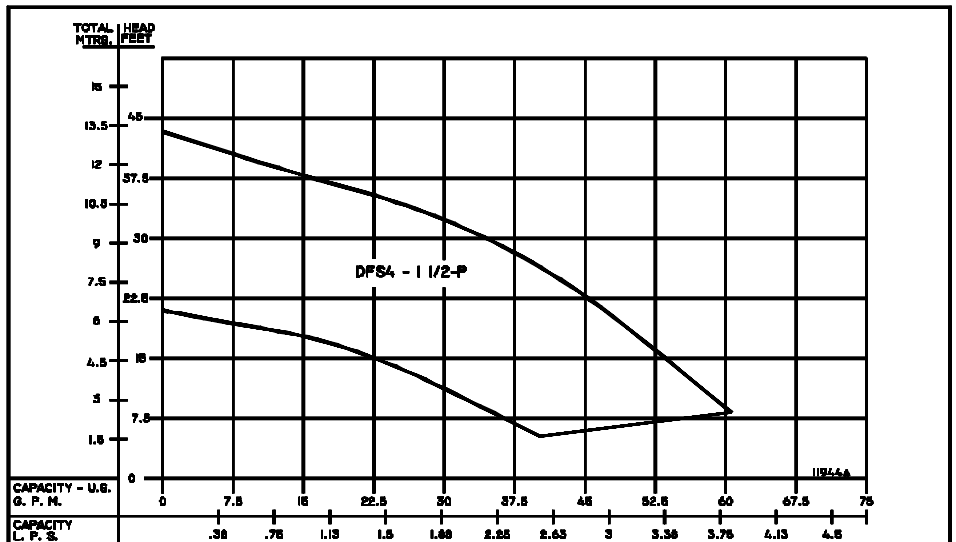

Individual performance curves should be checked for final selection.

SECTION	2C
PAGE	8
ISSUED	2/03
REPLACES	12/01

## FEATURES

- FOUR POSITION CASING**  
Centerline discharge can be located in any of four positions.
- IMPELLER**  
Semi-open with stainless steel insert.
- MECHANICAL SHAFT SEAL**  
Standard self-adjusting shaft seal for temperatures to 225°F (107°C) and pressures to 150 psi (1034kpa). Carbon seat and stainless steel seal face for long trouble-free service.
- MOTOR**  
Standard pump motors have open drip proof construction and is rated with jet pump service factors for continuous duty operation. Motors is 56 frame size with NEMA standard mounting flange, one piece threaded stainless steel shaft and ball/ball bearing construction.
- FACTORY TESTED**  
After careful assembly and inspection, **EVERY** pump is factory tested and will meet Hydraulic Institute standards.

MAXIMUM OPERATING CONDITIONS	
TEMPERATURE (For Standard Buna-N Seal)	185°F (85°C)
INLET PRESSURE	5 PSI (34.4kpa)
CASING WORKING PRESSURE	35 PSI (241kpa)

## MOTOR INFORMATION

50/60 Hz - 2800/3500 RPM - ODP

**Single Phase:** 3/4HP - 115/230 V.

**Three Phase:** 3/4HP - 230/460 V

Voltages may differ from some suppliers. Consult factory.  
**Overload Protection:** All single phase ODP have built-in overload protection. All three phase motors must be installed with a magnetic starter which provides full 3-leg protection. Failure to use correct starter and overloads will void motor warranty.

## MATERIALS OF CONSTRUCTION

PART	Material
Cover	Polyphenylene Sulfide
Casing	Polyphenylene Sulfide
Shaft	#303 Stainless
Impeller	Polyphenylene Sulfide
Shaft Seal	Carbon - Stainless Steel-Buna-N

## DIMENSIONS

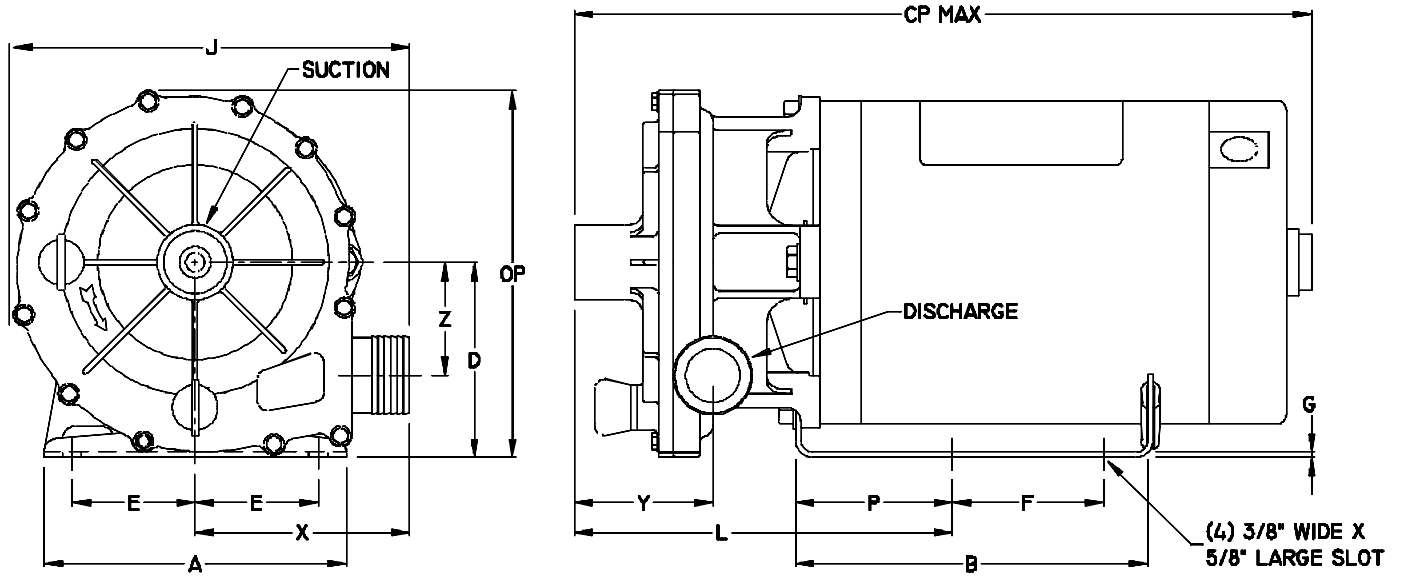

DIMENSIONS IN INCHES																	
MODEL	MOTOR FRAME SIZE	DISC	SUCT.	A	B	CP	D	E	F	G	J	L	OP	P	X	Y	Z
DFS4-1 <sup>1</sup> / <sub>2</sub> -P	56	1 <sup>1</sup> / <sub>2</sub> Hose	1 <sup>1</sup> / <sub>2</sub> Hose	6	6 <sup>57</sup> / <sub>64</sub>	14 <sup>1</sup> / <sub>64</sub>	3 <sup>7</sup> / <sub>8</sub>	2 <sup>7</sup> / <sub>16</sub>	3	3 <sup>32</sup> / <sub>32</sub>	7 <sup>55</sup> / <sub>64</sub>	7 <sup>1</sup> / <sub>2</sub>	7 <sup>19</sup> / <sub>64</sub>	3 <sup>7</sup> / <sub>64</sub>	4 <sup>1</sup> / <sub>4</sub>	2 <sup>3</sup> / <sub>4</sub>	2 <sup>1</sup> / <sub>4</sub>

DIMENSIONS IN MILLIMETERS																	
MODEL	MOTOR FRAME SIZE	DISC	SUCT.	A	B	CP	D	E	F	G	J	L	OP	P	X	Y	Z
DFS4-1 <sup>1</sup> / <sub>2</sub> -P	56	1 <sup>1</sup> / <sub>2</sub> Hose	1 <sup>1</sup> / <sub>2</sub> Hose	152	175	356	98	62	76	2.3	199	190	185	78	108	70	57

NOTE: HORIZONTAL MOUNTING ONLY.  
 DIMENSIONS SHOWN ABOVE ARE APPROXIMATE MAXIMUM DIMENSIONS FOR STANDARD PUMPS EQUIPPED WITH ODP MOTORS.

SECTION	2C
PAGE	10
ISSUED	2/03
REPLACES	12/01

# 60HZ & 50Hz PERFORMANCE CURVE



420 Third Street  
Piqua, Ohio 45356-0603  
Phone: (937) 778-8947 Fax: (937) 773-7157

## END SUCTION CENTRIFUGAL PUMPS

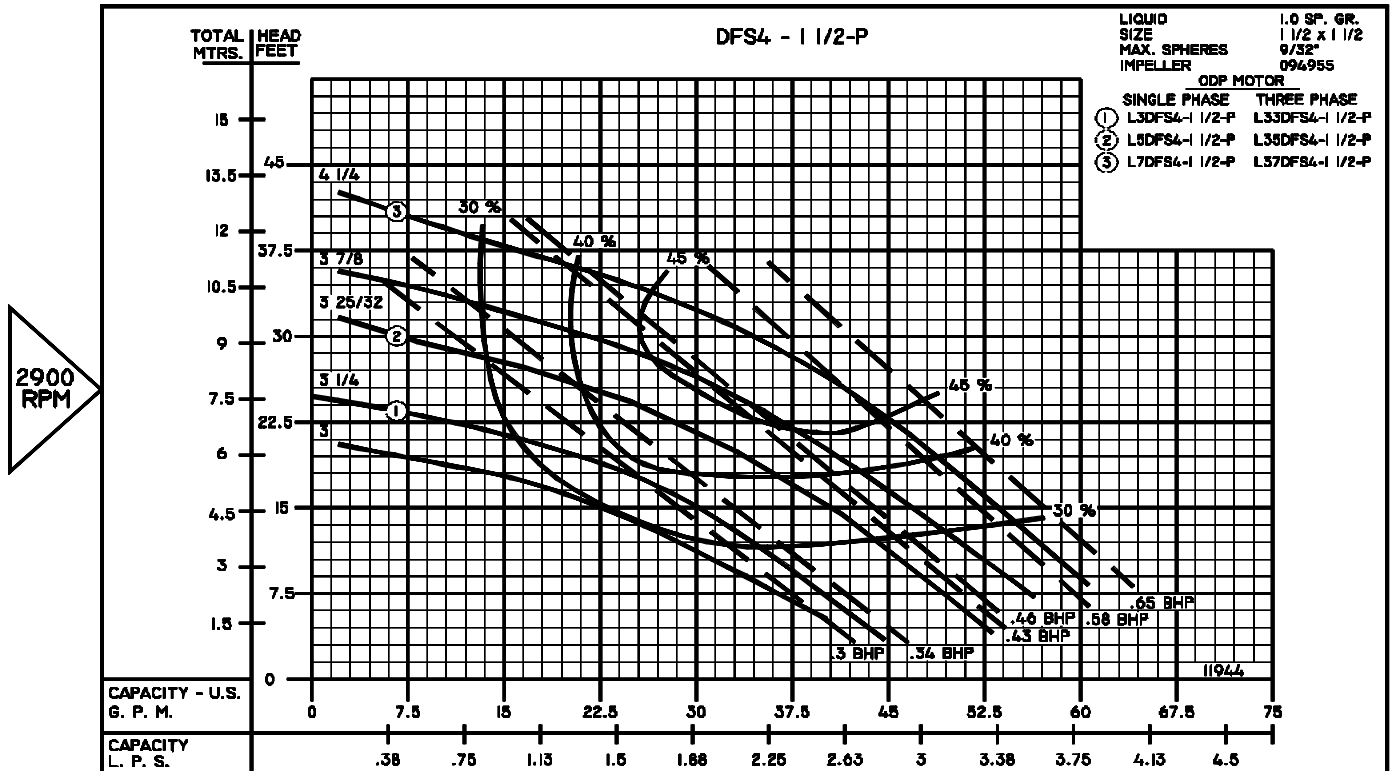
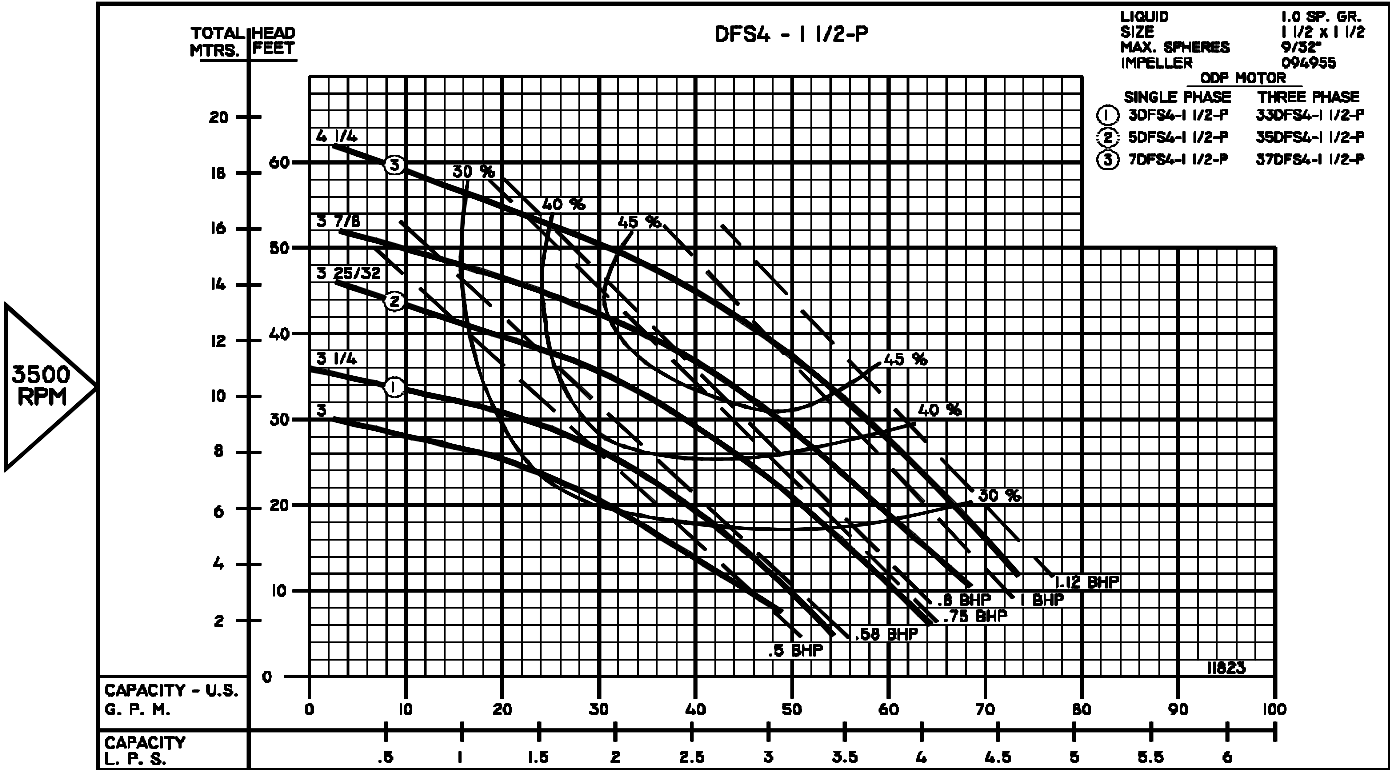

PUMPS & SYSTEMS

A Crane Co. Company