

Close Coupled Centrifugal Pumps

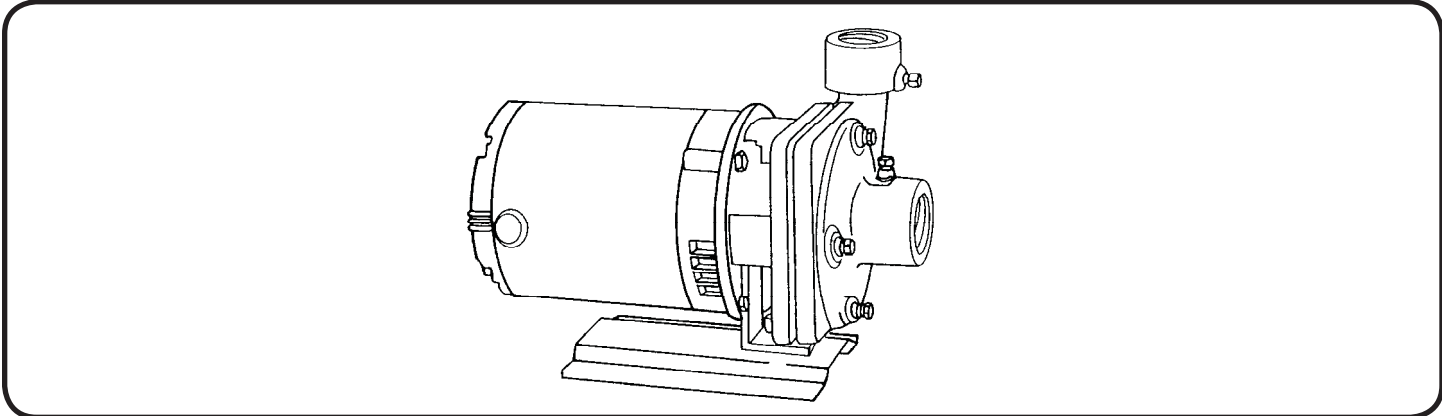

3500 RPM - 60Hz.
 CAPACITIES TO 80 GPM (5 LPS)
 HEADS TO 135 FEET (41 M)

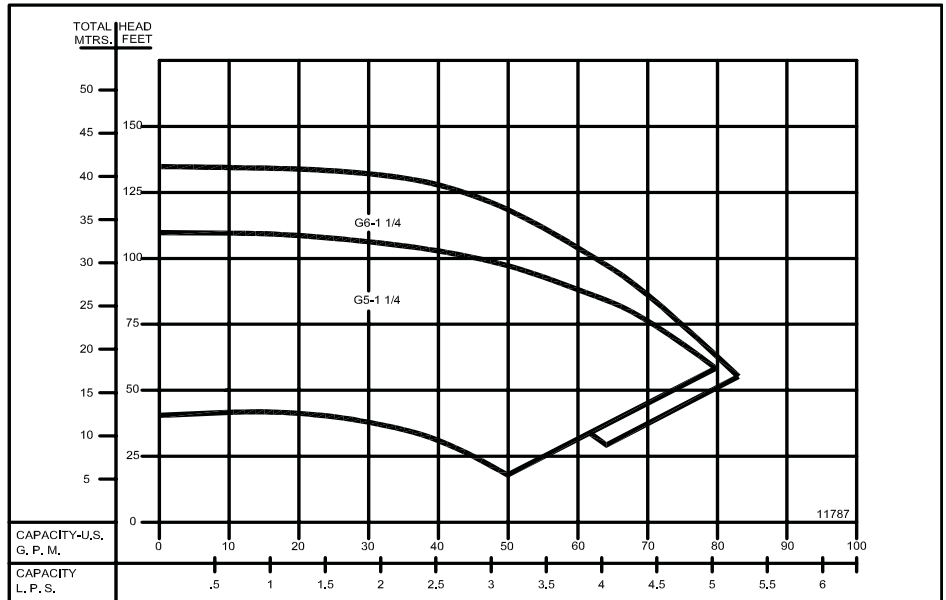

2900 RPM - 50Hz.
 CAPACITIES TO 68 GPM (4.3 LPS)
 HEADS TO 92 FEET (28 M)

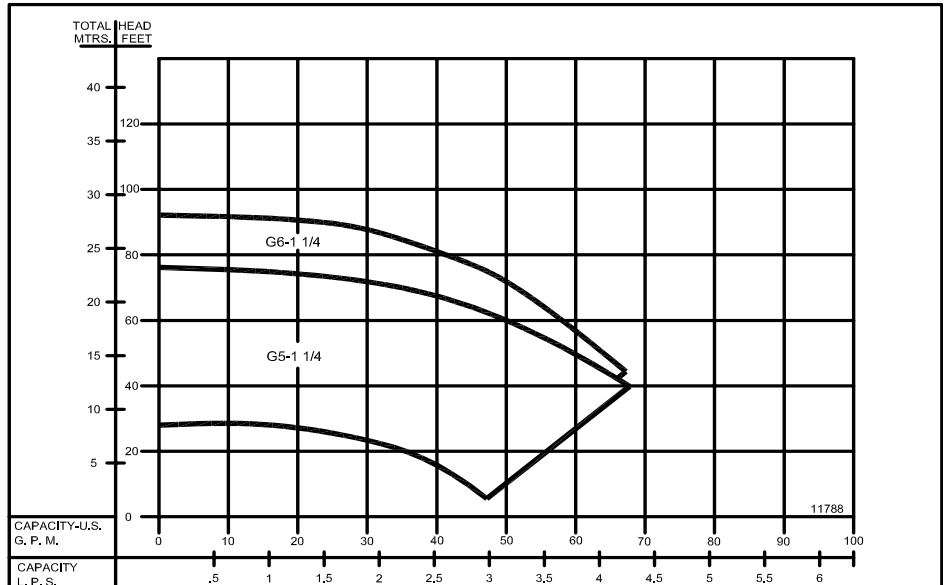

Close Coupled Centrifugal Pumps

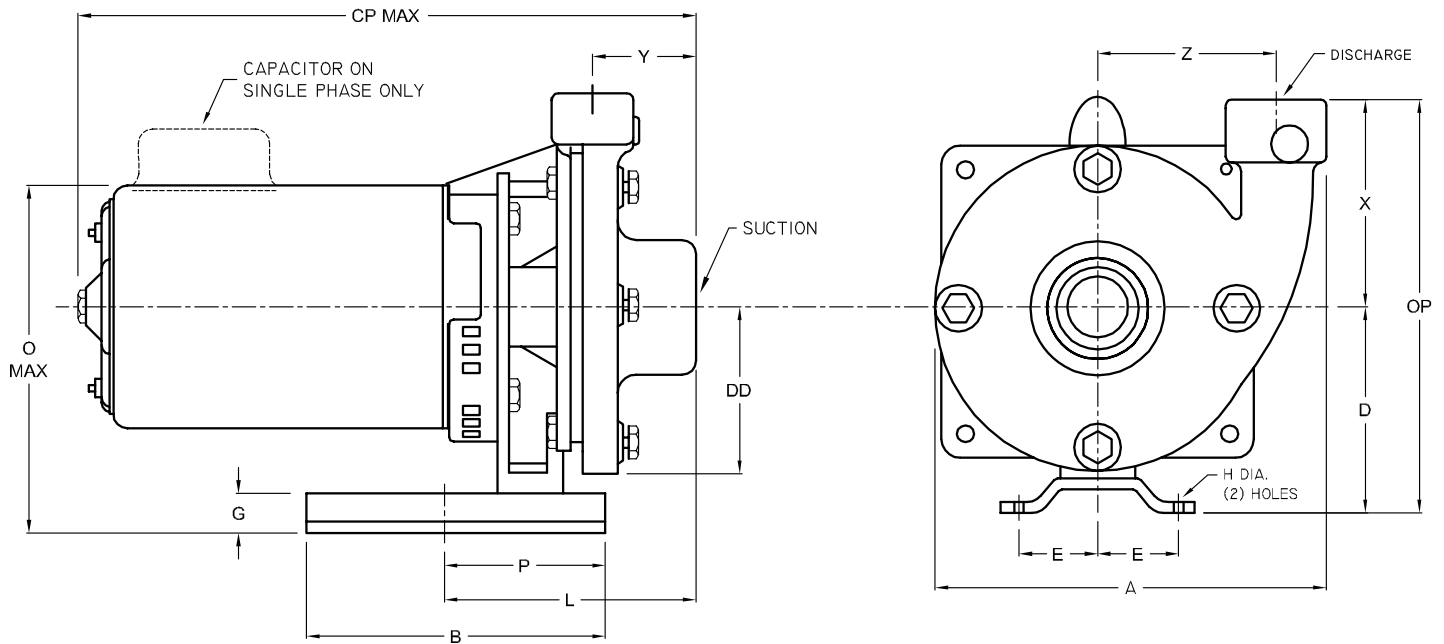

DIMENSIONS IN INCHES

MODEL	MOTOR FRAME SIZE	DISC NPT (in)	SUCT. NPT (in)	A	B	CP	D	DD	E	G	H	L	O	OP	P	X	Y	Z
G5-1¼	56	1¼	1½	7¾	8	15¾	4¾	3¼	1 ¹⁵ / ₁₆	¾	9/ ₁₆	6 ⁷ / ₈	8 ⁹ / ₁₆	9 ³ / ₈	4 ⁵ / ₁₆	4 ⁷ / ₁₆	2 ³ / ₈	3 ³ / ₈
G6-1¼	56	1¼	1½	8½	8	15 ⁷ / ₈	5¼	3¾	1 ¹⁵ / ₁₆	¾	9/ ₁₆	7¼	9 ¹ / ₁₆	10	4 ⁵ / ₁₆	4 ¹¹ / ₁₆	2½	3¾

DIMENSIONS IN MILLIMETERS

MODEL	MOTOR FRAME SIZE	DISC NPT (in)	SUCT. NPT (in)	A	B	CP	D	DD	E	G	H	L	O	OP	P	X	Y	Z
G5-1¼	56	1¼	1½	197	203	400	121	83	49	19	14	175	217	238	109	113	60	86
G6-1¼	56	1¼	1½	216	203	403	133	95	49	19	14	184	230	254	109	119	64	95

DIMENSIONS SHOWN ABOVE ARE APPROXIMATE MAXIMUM DIMENSIONS FOR STANDARD PUMPS EQUIPPED WITH ODP MOTORS.

Close Coupled Centrifugal Pumps

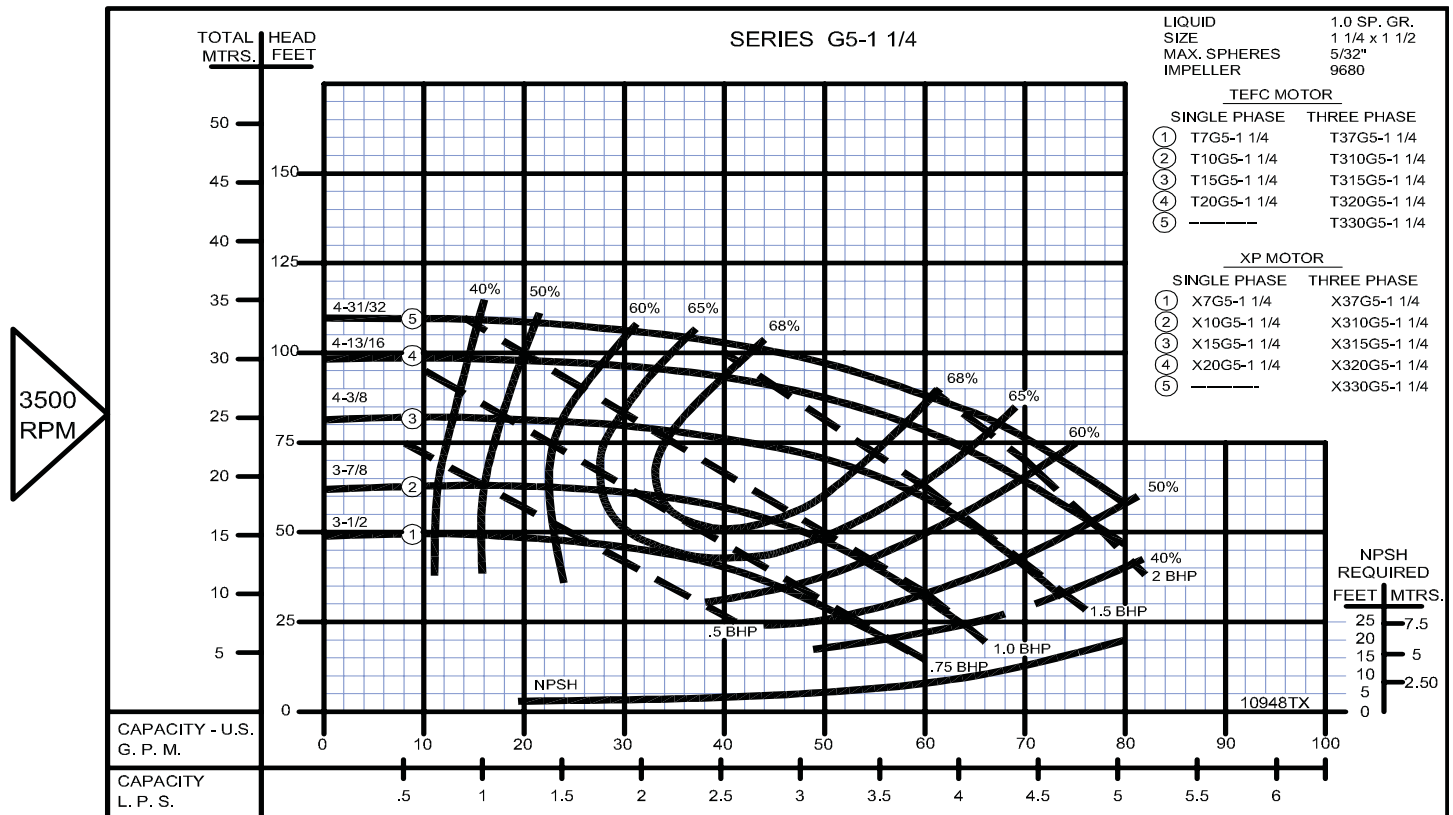
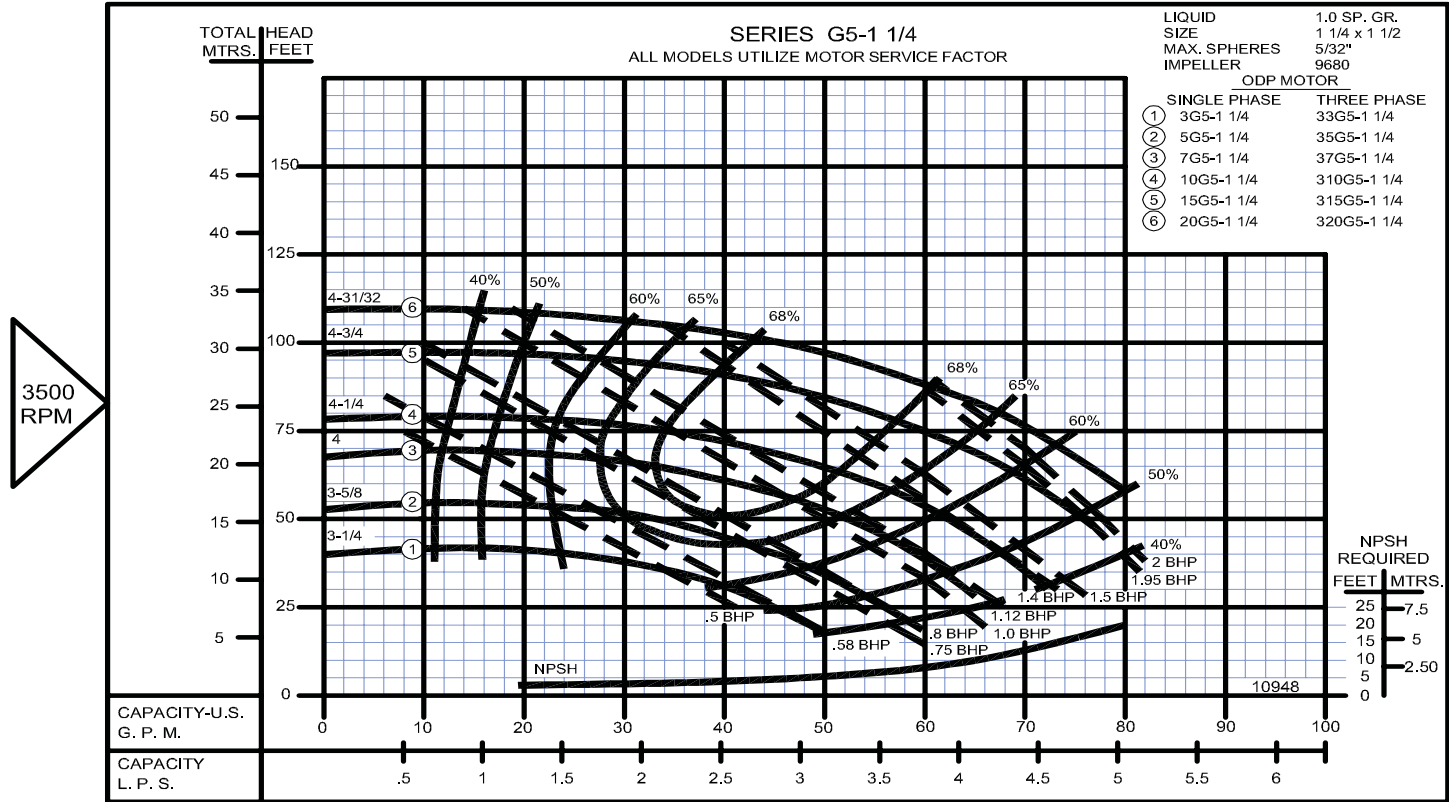

Close Coupled Centrifugal Pumps

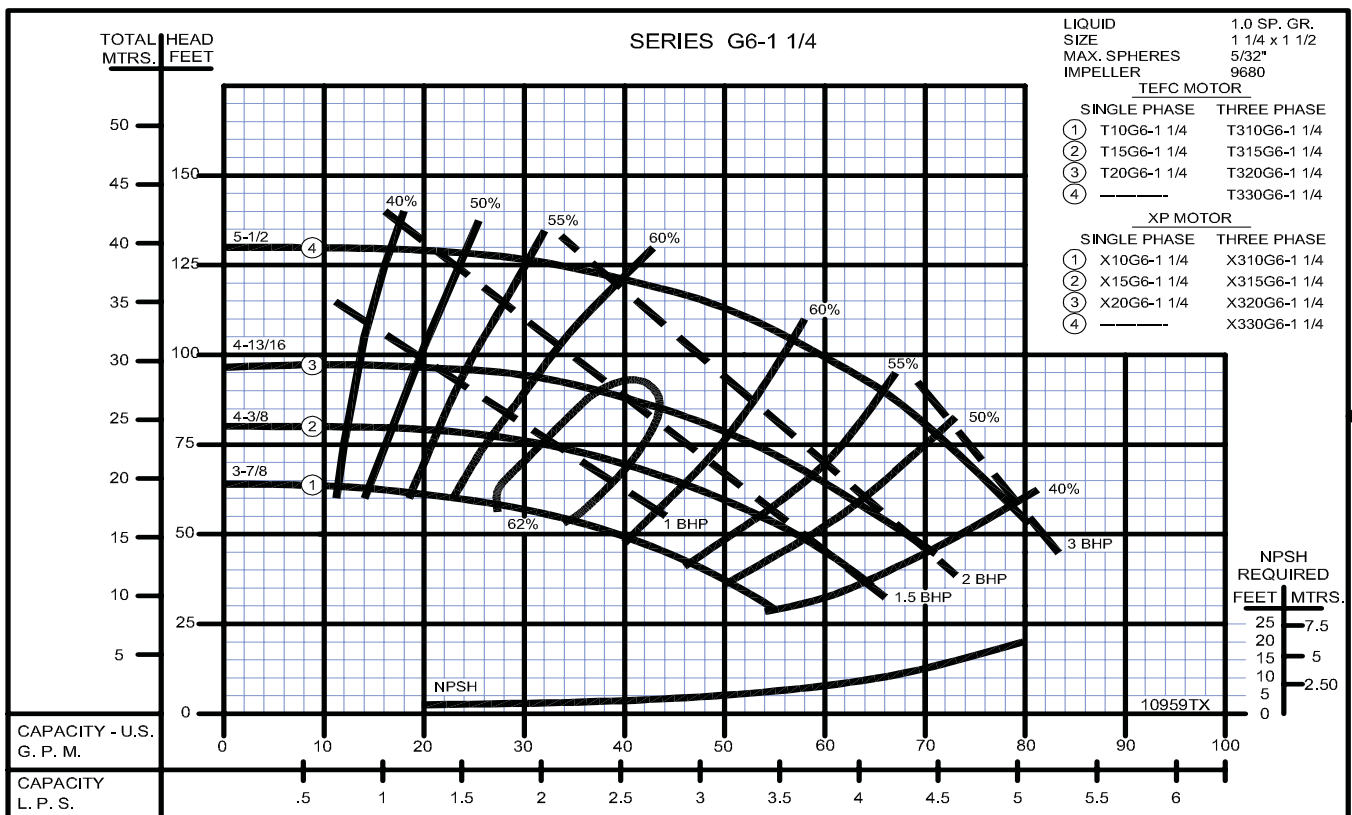
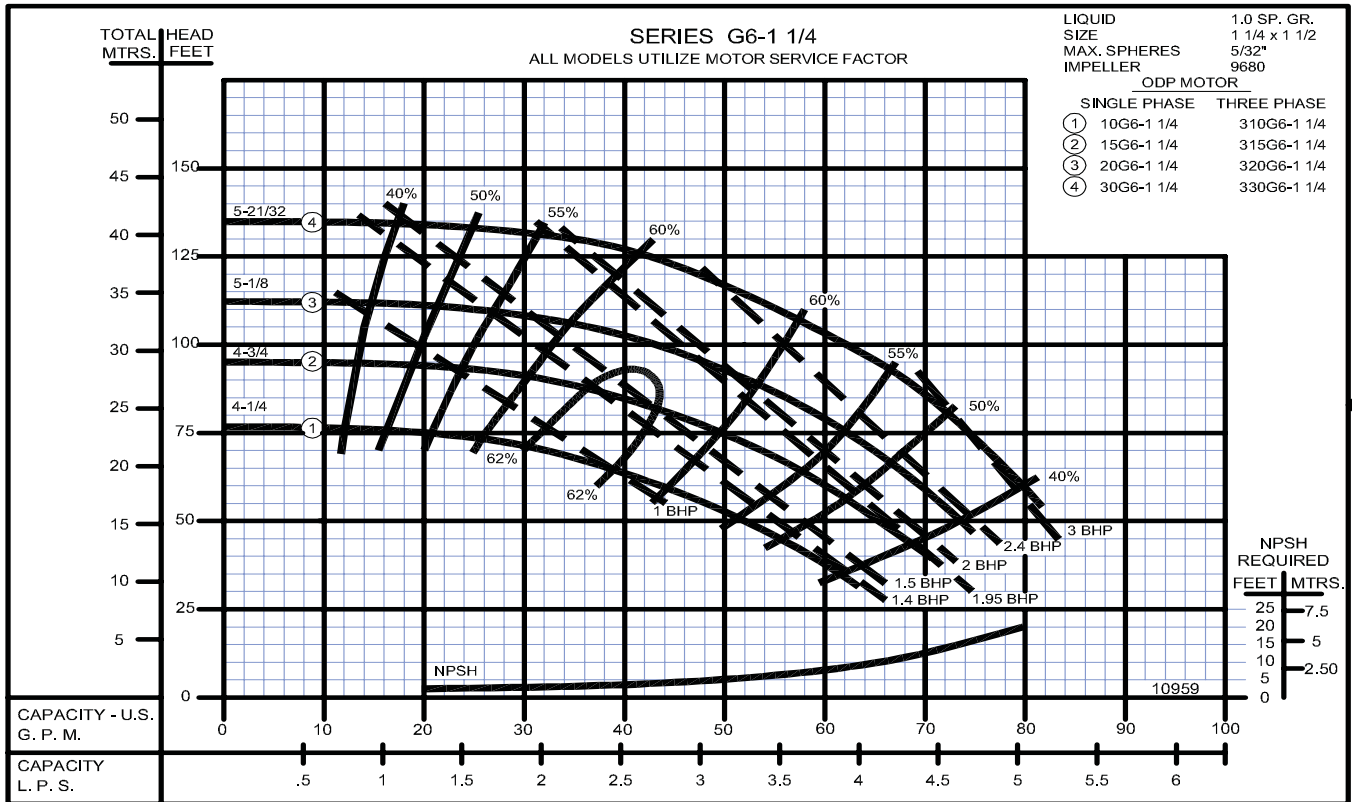

Close Coupled Centrifugal Pumps

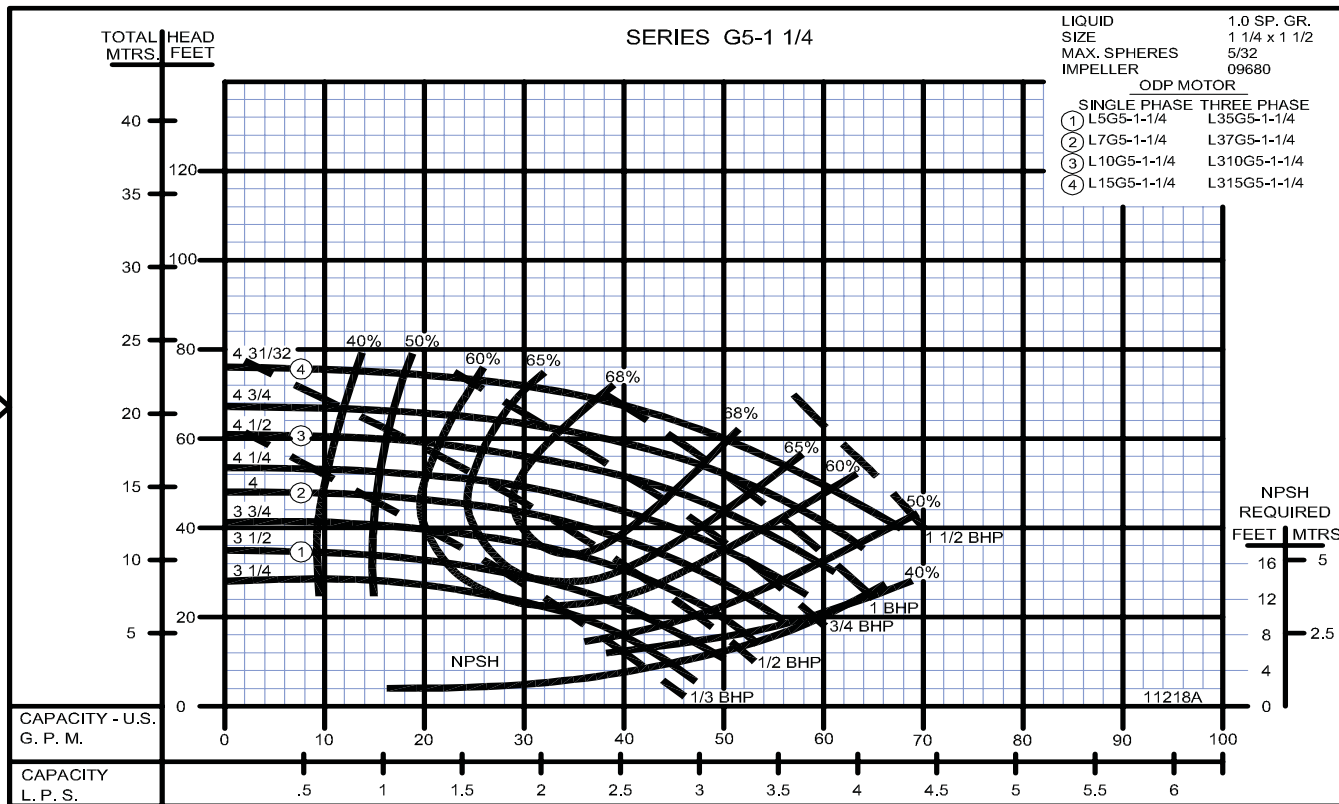

2900 RPM

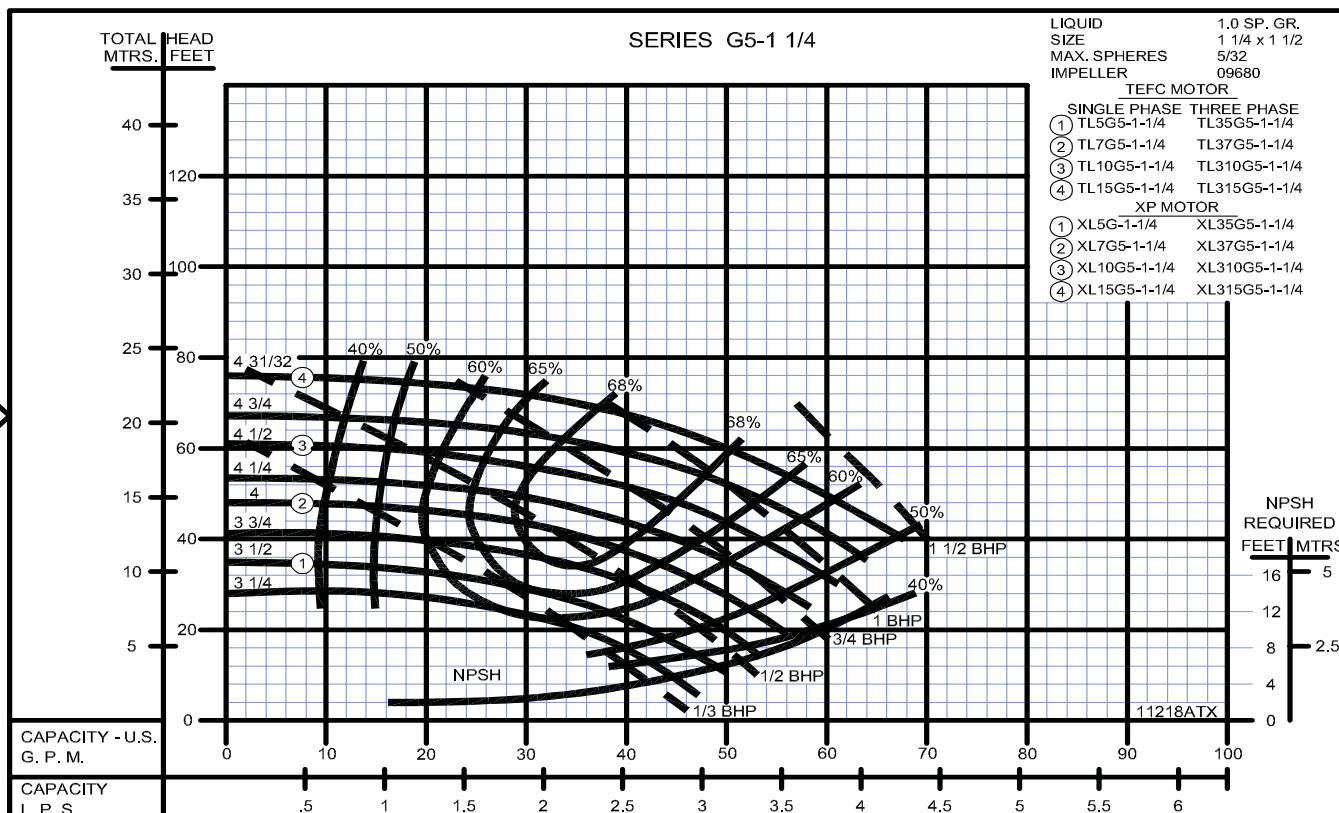

2900 RPM

SECTION 2B
PAGE 6
DATE 1/06



PUMPS & SYSTEMS

A Crane Co. Company

USA: (937) 778-8947 • Canada: (905) 457-6223 • International: (937) 615-3598

Close Coupled Centrifugal Pumps

