



Guzzler® Hand Pump GH-0400P



- Polypropylene pump body and flanges for excellent chemical resistance
- Accommodates 1/2" - 1" hose
- 10 GPM
- Rugged aluminum handle
- Clamp ring adjusts to 12 different handle orientations
- Available with horizontal or vertical handle
- Epoxy-coated aluminum clamp ring with stop brackets to prevent pump over-stroking

Performance

Flow Rate	Per minute ¹ : 10 Gal (37.9L) Per stroke: 0.44 Qt (0.42L)
Max Lift	12 ft (3.7 m) 22 ft (6.7 m) with check valve
Max Head	30 ft (9.1 m)
Max Pressure²	15 psi (1.0 kg/cm ²)
Max Service Temp	150°F (66°C)

¹: at 90 cpm
²: 20 psi with 19 in handle

Available Ports

	in	1/2	3/4	1
	cm	1.27	1.91	2.54
Hose (Smooth)				S
NPT Female (Tapped)		•		
NPT Male (Threaded)			•	

S Standard • Optional

Clamp Ring



Epoxy-coated Aluminum Clamp Ring with Stop Brackets limits upward travel of pump handle to prevent over-stroking

Optional Extra-Long Handle

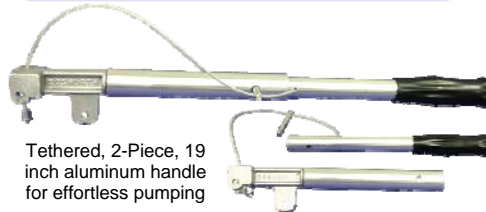

Tethered, 2-Piece, 19 inch aluminum handle for effortless pumping

Optional Stainless Steel Springs



Lightweight (LW) — 30 lb/in
Standard (Std) — 45 lb/in
Heavy Duty — 60 lb/in

Specifications / Options

Body & Ports *	Polypropylene / Black
Clamp Ring	Epoxy-coated Aluminum with Stop Brackets (Black)
Handle	Aluminum: Horizontal/Black, Vertical (Removable)/Silver
Valves *	Flapper, Duckbill, Umbrella
Diaphragm *	Buna-N, Buna-N Double Sided, Neoprene, Viton, EPDM, Silicone
Clevis/Button Assembly *	Polypropylene
Internal Spring *	None, Lightweight, Standard, Heavy-Duty (all stainless steel)
Other	Thru-Deck Mounting Kit (for vertical handle only)

* In contact with fluid

Valve Options

Flapper — General purpose liquid transfer



Duckbill — For dirty liquid and sewage. Permits mounting in any position.



Umbrella — Most efficient for pumping clean liquid. Also used for air and vacuum service.

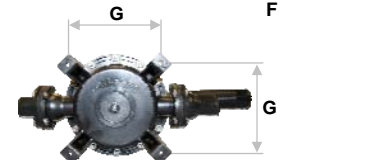
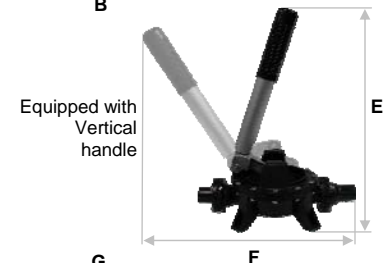
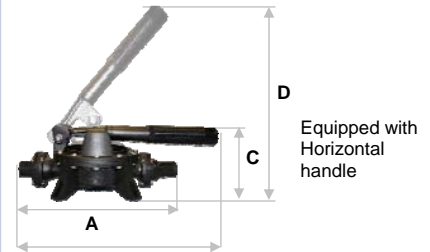
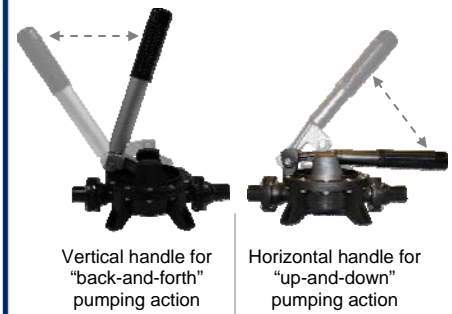

	in	cm
A	10-1/4	26.0
B	12-3/4	32.4
C	4-5/16	11.0
D	11-1/2	29.2
E	13-5/16	33.8
F	12-3/4	32.4
G	4-5/16	11.0
Mounting Holes	1/4	0.64
Bolt Circle Diam.	6-1/8	15.6
Weight	1.70 lb	0.77 kg

Guzzler® Hand Pump GH-0400P



Example: GH-0400P-211-24-5050-00

- Guzzler Hand Pump
- Model style #0400P: Polypropylene Body, Opp. Side Ports
- Horizontal Handle (Black)
- Buna-N Flapper Valves
- Buna Diaphragm
- Polypropylene Clevis/Button Assembly
- Epoxy-coated Aluminum Clamp Ring with Stop Brackets
- Inlet: 1" Smooth
- Outlet: 1" Smooth
- No Spring

Guzzler Product	
Option	Code
Hand Pump	GH

Style (Family)	
Option	Code
Polypropylene, Opp. Side Ports	0400P

Handle	
Option	Code
Horizontal/Black	2
Vertical/Silver (Removable)	4
Horizontal/1 9/16"-Piece/Tethered	5

Valves	
Option	Code
Flapper (Buna-N)	1
Flapper (White Buna)	2
Flapper (Neoprene)	3
Flapper (Viton)	4
Flapper (EPDM)	5
Duckbill (Buna-N)	6
Umbrella (Silicone)	7

Diaphragm	
Option	Code
Buna Nitrile	1
Buna-N 3-Ply	2
Neoprene	3
Viton	4
EPDM	5
Silicone	7

GH - 0400P - 2 1 1 - 2 4 - 50 50 - 00

Clevis/Button Assembly	
Option	Code
Polypropylene	2

Clamp Ring	
Option	Code
Epoxy-coated Alum w/Stop Brackets	4

Hose Connections		
Option	Code	
	Inlet	Outlet
1/2" NPT Tapped	31	31
3/4" NPT Threaded	42	42
1" Smooth	50	50

Internal Spring	
Option	Code
No Spring	00
Std Weight SS	10
Lightweight SS	20
Heavy Duty SS	30

