

BARNES®

INSTALLATION and OPERATION MANUAL Submersible Non-Clog Pump

Explosion Proof, Class I, Groups C & D, Division 1

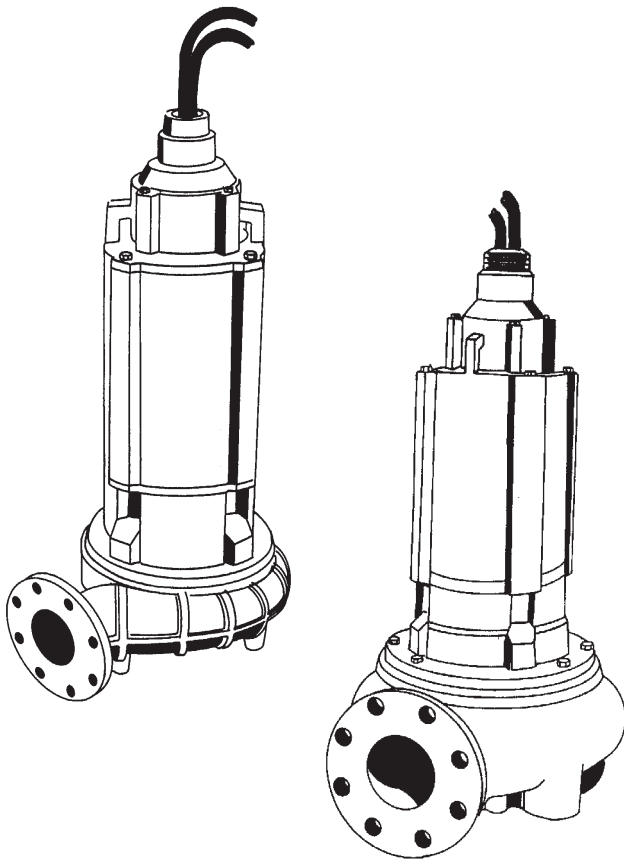

Series: 4XSE-A, 60Hz
3.0 - 7.5HP, 1150RPM
5.0 - 20HP, 1750RPM

Series: 4XSE-HA, 60Hz
3.0 - 7.5HP, 1150RPM
7.5 - 15HP, 1750RPM

(Standard & High Efficiency)

IMPORTANT!

Read all instructions in this manual before operating pump.

As a result of Crane Pumps & Systems, Inc., constant product improvement program, product changes may occur. As such Crane Pumps & Systems reserves the right to change product without prior written notification.

CRANE

A Crane Co. Company

PUMPS & SYSTEMS

420 Third Street
Piqua, Ohio 45356
Phone: (937) 778-8947
Fax: (937) 773-7157
www.cranepumps.com

83 West Drive, Bramton
Ontario, Canada L6T 2J6
Phone: (905) 457-6223
Fax: (905) 457-2650



Form No. 084838-Rev. L

TABLE OF CONTENTS

SAFETY FIRST	3
A. PUMP SPECIFICATIONS	4 - 5
B. GENERAL INFORMATION	6
C. INSTALLATION	6 - 11
ELECTRICAL DATA	8
D. START-UP OPERATION	11
E. PREVENTATIVE MAINTENANCE	11
F. SERVICE and REPAIR	12 - 13
G. REPLACEMENT PARTS.....	13
TROUBLE SHOOTING	14
4XSE-A CROSS-SECTION, (Fig. 8)	15
4XSE-A EXPLODED VIEW, (Fig. 9).....	16
4XSE-A PARTS LIST	17 & 21
4XSE-HA CROSS-SECTION, (Fig. 10).....	18
4XSE-HAEXPLODED VIEW, (Fig. 11)	19
4XSE-HAPARTS LIST	20 - 21
RETURNED GOODS POLICY.....	22
WARRANT	23
START-UP REPORT	25 - 26
WARRANTY REGISTRATION	
SPECIAL TOOLS AND EQUIPMENT	
INSULATION TESTER (MEGGER)	
DIELECTRIC TESTER	
SEAL TOOL KIT (see parts list)	
PRESSURE GAUGE KIT (see parts list)	

SAFETY FIRST!

Please Read This Before Installing Or Operating Pump.
This information is provided for **SAFETY and to PREVENT EQUIPMENT PROBLEMS**. To help recognize this information, observe the following symbols:



IMPORTANT! Warns about hazards that can result in personal injury or Indicates factors concerned with assembly, installation, operation, or maintenance which could result in damage to the machine or equipment if ignored.

CAUTION ! Warns about hazards that can or will cause minor personal injury or property damage if ignored. Used with symbols below.

WARNING ! Warns about hazards that can or will cause serious personal injury, death, or major property damage if ignored. Used with symbols below.



Hazardous fluids can cause fire or explosions, burnes or death could result.



Extremely hot - Severe burnes can occur on contact.



Biohazard can cause serious personal injury.



Hazardous fluids can Hazardous pressure, eruptions or explosions could cause personal injury or property damage.



Rotating machinery Amputation or severe laceration can result.



Hazardous voltage can shock, burn or cause death.

Only qualified personnel should install, operate and repair pump. Any wiring of pumps should be performed by a qualified electrician.



WARNING ! - To reduce risk of electrical shock, pumps and control panels must be properly grounded in accordance with the National Electric Code (NEC) or the Canadian Electrical Code (CEC) and all applicable state, province, local codes and ordinances.



WARNING! - To reduce risk of electrical shock, always disconnect the pump from the power source before handling or servicing. Lock out power and tag.



WARNING! Operation against a closed discharge valve will cause premature bearing and seal failure on any pump, and on end suction and self priming pump the heat build may cause the generation of steam with resulting dangerous pressures. It is recommended that a high case temperature switch or pressure relief valve be installed on the pump body.



CAUTION ! Never operate a pump with a plug-in type power cord without a ground fault circuit interrupter.



CAUTION! Pumps build up heat and pressure during operation-allow time for pumps to cool before handling or servicing.



WARNING! - **DO NOT** pump hazardous materials (flammable, caustic, etc.) unless the pump is specifically designed and designated to handle them.



Do not block or restrict discharge hose, as discharge hose may whip under pressure.



WARNING! - DO NOT wear loose clothing that may become entangled in the impeller or other moving parts.



WARNING! - Keep clear of suction and discharge openings. **DO NOT** insert fingers in pump with power connected.



Always wear eye protection when working on pumps.



Make sure lifting handles are securely fastened each time before lifting. **DO NOT** operate pump without safety devices in place. Always replace safety devices that have been removed during service or repair. Secure the pump in its operating position so it can not tip over, fall or slide.



DO NOT exceed manufacturers recommendation for maximum performance, as this could cause the motor to overheat.



DO NOT remove cord and strain relief. Do not connect conduit to pump.



WARNING! Cable should be protected at all times to avoid punctures, cut, bruises and abrasions - inspect frequently. Never handle connected power cords with wet hands.



WARNING! To reduce risk of electrical shock, all wiring and junction connections should be made per the NEC or CEC and applicable state or province and local codes. Requirements may vary depending on usage and location.



WARNING! Submersible Pumps are not approved for use in swimming pools, recreational water installations, decorative fountains or any installation where human contact with the pumped fluid is common.



WARNING! Products Returned Must Be Cleaned, Sanitized, Or Decontaminated As Necessary Prior To Shipment, To Insure That Employees Will Not Be Exposed To Health Hazards In Handling Said Material. All Applicable Laws And Regulations Shall Apply.



Bronze/brass and bronze/brass fitted pumps may contain lead levels higher than considered safe for potable water systems. Lead is known to cause cancer and birth defects or other reproductive harm. Various government agencies have determined that leaded copper alloys should not be used in potable water applications. For non-leaded copper alloy materials of construction, please contact factory.



IMPORTANT! - Crane Pumps & Systems, Inc. is not responsible for losses, injury, or death resulting from a failure to observe these safety precautions, misuse or abuse of pumps or equipment.

**SECTION: A - PUMP SPECIFICATIONS:
4XSE-A**

DISCHARGE 4" NPT, 125 lb. Flange Horizontal
LIQUID TEMPERATURE ... 104°F (40°C) Continuous
VOLUTE Cast Iron ASTM A-48, Class 30
MOTOR HOUSING Cast Iron ASTM A-48, Class 30
SEAL PLATE Cast Iron ASTM A-48, Class 30
IMPELLER:
Design..... 2 Vane, Open, With Pump Out Vanes on Back Side. Dynamically Balanced ISO G6.3
Material Cast Iron ASTM A-48, Class 30
SHAFT 416 Stainless Steel
SQUARE RINGS..... Buna-N
HARDWARE 300 Series Stainless Steel
LIFTING CHAIN Yoke, Galvanized
PAINT Air Dry Enamel.
SEAL: *Design* Tandem Mechanical, Oil Filled Reservoir.
Material..... Rotating Faces - Carbon Stationary Faces - Ceramic Elastomer - Buna-N Hardware -300 Series Stainless
CORD ENTRY 25 ft. (7.6m) Std. Cord. Epoxy Sealed Housing with Secondary Pressure Grommet for Sealing and Strain Relief
SPEED 1150 & 1750 RPM (Nominal)

UPPER BEARING:
Design Single Row, Ball, Grease Lubricated
Load Radial
LOWER BEARING:
Design Double Row, Ball, Grease Lubricated
Load..... Radial & Thrust
MOTOR: *Design* NEMA L - Single Phase, NEMA B Three Phase Torque Curve. Air-Filled, Squirrel Cage Induction, Class I, Groups C & D, Division 1, Explosion Proof
Insulation..... Class F.
SINGLE PHASE Capacitor Start/Induction Run. Start Capacitors Included with Pump Assembly. Controls Require External Overload Protection.
THREE PHASE Dual Voltage 230/460; Requires Overload Protection to be Included in control panel.
MOISTURE SENSOR Normally Open (N/O), Requires Relay in Control Panel
TEMPERATURE SENSOR..... Normally Closed (N/C), Requires Relay in Control Panel
OPTIONAL EQUIPMENT.. Seal Material, Impeller Trims, Cord Length

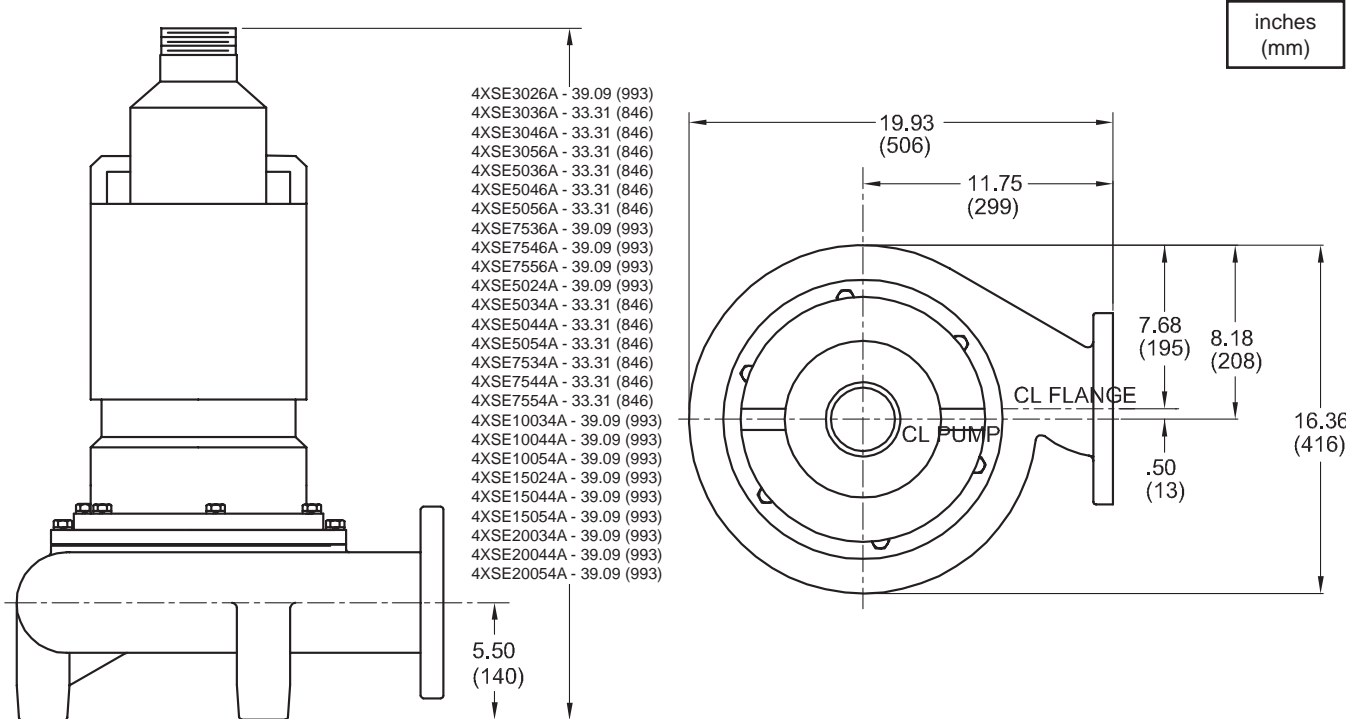

IMPORTANT !

- 1.) MOISTURE AND TEMPERATURE SENSORS MUST BE CONNECTED TO VALIDATE THE UL LISTING.
- 2.) A **NON-SPARKING** BREAK AWAY FITTING MUST BE USED TO VALIDATE THE UL LISTING.
- 3.) A SPECIAL MOISTURE SENSOR RELAY IS REQUIRED IN THE CONTROL PANEL FOR PROPER OPERATION OF THE MOISTURE SENSORS. CONTACT BARNES PUMPS FOR INFORMATION CONCERNING MOISTURE SENSING RELAYS FOR CUSTOMER SUPPLIED CONTROL PANELS.
- 4.) THESE PUMPS ARE UL LISTED FOR PUMPING WATER AND WASTEWATER. **DO NOT USE TO PUMP FLAMMABLE LIQUIDS.**
- 5.) INSTALLATIONS SUCH AS DECORATIVE FOUNTAINS OR WATER FEATURES PROVIDED FOR VISUAL ENJOYMENT MUST BE INSTALLED IN ACCORDANCE WITH THE NATIONAL ELECTRIC CODE ANSI/NFPA 70 AND/OR THE AUTHORITY HAVING JURISDICTION. THIS PUMP IS NOT INTENDED FOR USE IN SWIMMING POOLS, RECREATIONAL WATER PARKS, OR INSTALLATIONS IN WHICH HUMAN CONTACT WITH PUMPED MEDIA IS A COMMON OCCURRENCE.

**SECTION: A - PUMP SPECIFICATIONS:
4XSE-HA**

DISCHARGE 4" NPT, 125 lb. Flange Horizontal
LIQUID TEMPERATURE ... 104°F (40°C) Continuous
VOLUTE Cast Iron ASTM A-48, Class 30
 With Bronze Wear Ring
MOTOR HOUSING Cast Iron ASTM A-48, Class 30
SEAL PLATE Cast Iron ASTM A-48, Class 30
IMPELLER:
Design..... 2 Vane, Open, With Pump Out
 Vanes on Back Side. Dynamically
 Balanced ISO G6.3
Material Cast Iron ASTM A-48, Class 30
SHAFT 416 Stainless Steel
SQUARE RINGS..... Buna-N
HARDWARE 300 Series Stainless Steel
LIFTING CHAIN Yoke, Galvanized
PAINT Air Dry Enamel.
SEAL: *Design* Tandem Mechanical, Oil Filled
 Reservoir.
Material..... Rotating Faces - Carbon
 Stationary Faces - Ceramic
 Elastomer - Buna-N
 Hardware -300 Series Stainless
CORD ENTRY..... 25 ft. (7.6m) Std. Cord. Epoxy
 Sealed Housing with Secondary
 Pressure Grommet for Sealing and
 Strain Relief

SPEED 1150 & 1750 RPM (Nominal)
UPPER BEARING:
Design Single Row, Ball, Grease Lubricated
Load Radial
LOWER BEARING:
Design Double Row, Ball, Grease Lubricated
Load..... Radial & Thrust
MOTOR: *Design* NEMA L - Single Phase, NEMA B
 Three Phase Torque Curve.
 Air-Filled, Squirrel Cage Induction,
 Class I, Groups C & D, Division 1,
 Explosion Proof
Insulation..... Class F.
SINGLE PHASE Capacitor Start/Induction Run.
 Start Capacitors Included with
 Pump Assembly. Controls Require
 External Overload Protection.
THREE PHASE Dual Voltage 230/460; Requires
 Overload Protection to be Included
 in control panel.
MOISTURE SENSOR Normally Open (N/O), Requires
 Relay in Control Panel
TEMPERATURE SENSOR..... Normally Closed (N/C), Requires
 Relay in Control Panel
OPTIONAL EQUIPMENT.. Seal Material, Impeller Trims,
 Cord Length

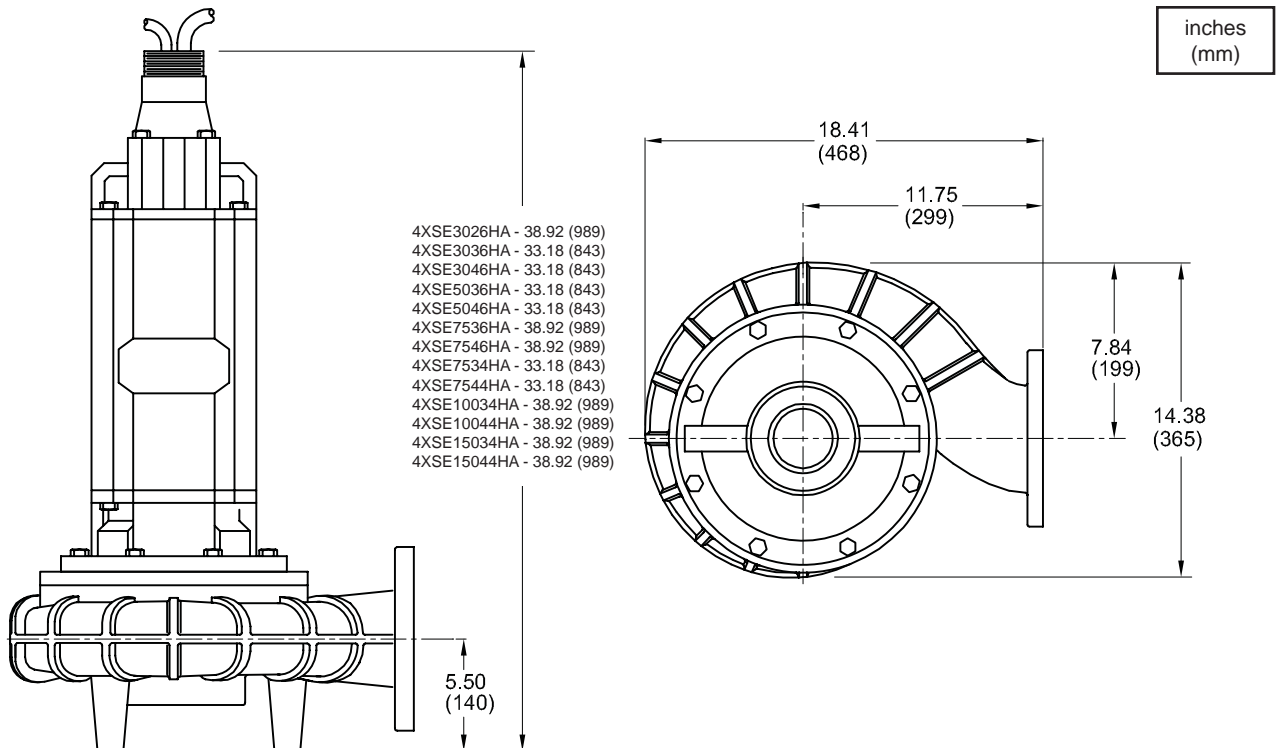

IMPORTANT !

- 1.) MOISTURE AND TEMPERATURE SENSORS MUST BE CONNECTED TO VALIDATE THE UL LISTING.
- 2.) A **NON-SPARKING** BREAK AWAY FITTING MUST BE USED TO VALIDATE THE UL LISTING.
- 3.) A SPECIAL MOISTURE SENSOR RELAY IS REQUIRED IN THE CONTROL PANEL FOR PROPER OPERATION OF THE MOISTURE SENSORS. CONTACT BARNES PUMPS FOR INFORMATION CONCERNING MOISTURE SENSING RELAYS FOR CUSTOMER SUPPLIED CONTROL PANELS.
- 4.) THESE PUMPS ARE UL LISTED FOR PUMPING WATER AND WASTEWATER. **DO NOT USE TO PUMP FLAMMABLE LIQUIDS.**
- 5.) INSTALLATIONS SUCH AS DECORATIVE FOUNTAINS OR WATER FEATURES PROVIDED FOR VISUAL ENJOYMENT MUST BE INSTALLED IN ACCORDANCE WITH THE NATIONAL ELECTRIC CODE ANSI/NFPA 70 AND/OR THE AUTHORITY HAVING JURISDICTION. THIS PUMP IS NOT INTENDED FOR USE IN SWIMMING POOLS, RECREATIONAL WATER PARKS, OR INSTALLATIONS IN WHICH HUMAN CONTACT WITH PUMPED MEDIA IS A COMMON OCCURRENCE.

SECTION B: GENERAL INFORMATION

B-1) To the Purchaser:

Congratulations! You are the owner of one of the finest pumps on the market today. CP&S pumps are products engineered and manufactured of high quality components. Over one hundred years of pump building experience along with a continuing quality assurance program combine to produce a pump which will stand up to the toughest applications. This manual will provide helpful information concerning installation, maintenance, and proper service guidelines.

B-2) Receiving:

Upon receiving the pump, it should be inspected for damage or shortages. If damage has occurred, file a claim immediately with the company that delivered the pump. If the manual is removed from the packaging, do not lose or misplace.

B-3) Storage:

Short Term- CP&S Pumps are manufactured for efficient performance following short inoperative periods in storage. For best results, pumps can be retained in storage, as factory assembled, in a dry atmosphere with constant temperatures for up to six (6) months. Long Term- Any length of time exceeding six (6) months, but not more than twenty-four (24) months. The unit should be stored in a temperature controlled area, a roofed over walled enclosure that provides protection from the elements (rain, snow, wind-blown dust, etc.), and whose temperature can be maintained between +40 deg. F and +120 deg. F. (4.4 - 49°C). Pump should be stored in its original shipping container. On initial start up, rotate impeller by hand to assure seal and impeller rotate freely. If it is required that the pump be installed and tested before the long term storage begins, such installation will be allowed provided:

- 1.) The pump is not installed under water for more than one (1) month.
- 2.) Immediately upon satisfactory completion of the test, the pump is removed, thoroughly dried, repacked in the original shipping container, and placed in a temperature controlled storage area.

B-4) Service Centers:

For the location of the nearest Barnes Service Center, check your Barnes representative or Crane Pumps & Systems, Inc., Service Department in Piqua, Ohio, telephone (937) 778-8947 or Crane Pumps & Systems Canada, in Brampton, Ontario, (905) 457-6223.

SECTION C: INSTALLATION

C-1) Location:

These self-contained pumping units are Listed for Class I, Groups C & D, Division 1 locations and are recommended for use in a sump, lift station or basin. This pump is designed for submerged continuous duty (15 minutes duty in air at nameplate horsepower), pumping sewage, effluent, wastewater or other nonexplosive or noncorrosive liquids not above 104°F (40°C). Never install the pump in a trench, ditch or hole with a dirt bottom; the legs will sink into the dirt and the suction will become plugged.

C-1.1) Submergence:

It is recommended that the pump be operated in the submerged condition and the sump liquid level should never be less than dimension "A" in (See Fig. 1). The time required to draw the well down from top of motor to the minimum submergence level should not be greater than 15 minutes.

NOTE: Outer shaft seal must be in liquid when motor is operated, whether motor is submerged or in air.

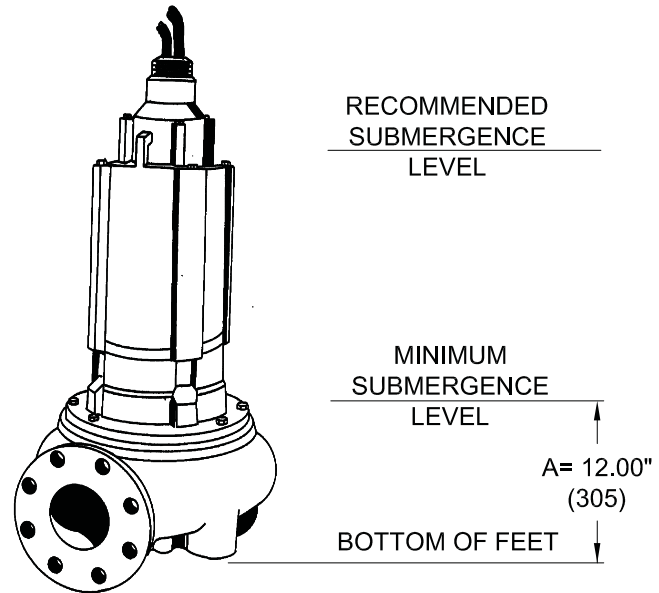

FIGURE 1

C-2) Discharge:

Discharge piping should be as short as possible. Both a check valve and a shut-off valve are recommended for each pump being used. The check valve is used to prevent backflow into the sump. Excessive backflow can cause flooding and/or damage to the pump. The shut-off valve is used to stop system flow during pump or check valve servicing.



WARNING ! - These pumps are suitable for application in CLASS I, GROUPS C & D, HAZARDOUS LOCATIONS and require a non-sparking break away fitting. Failure to use the non-sparking BAF voids warranty.

Barnes Pumps supplies a Non-Sparking break away fitting discharge system designed to allow the submersible wastewater pump to be installed or removed without requiring personnel to enter the wet well. Place the Break Away Fitting (BAF) in position. Temporarily secure the guide rails in the upper mounting brackets and locate the base elbow on the bottom of the wet well. Level the base elbow with grout and/or shims. Install the intermediate support brackets, if required. Make sure the rails are in a true vertical position so the pump will clear the access opening and will slide freely down the rails into place on the discharge base elbow. Once the rails are in proper alignment, bolt the base elbow into the floor of the station and connect the discharge pipe to the elbow. Connect the movable portion and other supplied fittings of the BAF onto the pump and lower into wet well. See the Break Away Fitting manual for more information.

If a rigid conduit is used to install the pump it must meet Class I, Division 1 requirements of the National Electrical Code. Conduit must be stainless steel or coated metal, resistant to sewage water.

C-3) Liquid Level Controls: Intrinsically Safe



WARNING ! - Level control floats used within the hazardous location, must be in an intrinsically safe control circuit suitable for use in CLASS I, GROUPS C & D, HAZARDOUS LOCATIONS.

The level controls are to be supported by a mounting bracket that is attached to the sump wall, cover or junction box. Cord grips are used to hold the cords in place on the mounting bracket. The control level can be changed by loosening the grip and adjusting the cord length as per the plans and specifications. Be certain that the level controls cannot hang up or foul in it's swing and that the entire pump is still submerged when the level control is in the "Off" mode.

A Warrick® Control intrinsically safe relay, Series 27, is an acceptable panel mounted relay, providing the relay is properly installed and maintained.

The primary (A.C. supply line) circuit is not intrinsically safe, therefore the relay must be located in a "SAFE" location (a place that is not classified as a hazardous location). The secondary circuit is intrinsically safe, however, any splice must be made in a "SAFE" location and any control cord that is cut or damaged must be replaced immediately.

C-3.1) Level Control Float System:

It is recommended to use a two float, on and off, level control system. An additional float, incorporated with an alternator switching system will be required for a duplex system. A high level alarm may be required to alert maintenance personnel. A low level cut off may be required to provide system shutdown if the main level control system malfunctions. The off or low level float should be positioned so that the liquid level never drops below the minimum submergence level.

C-4) Electrical Connections:



WARNING! - All model pumps and control panels must be properly grounded per the NATIONAL ELECTRIC CODE or CANADIAN ELECTRIC CODE, State, Province and local codes. Improper grounding voids warranty.

All electrical controls and motor starting equipment must be installed outside the hazardous area unless approved explosion proof controls are used.

C-4.1) Power and Control Cords:

The cord assembly mounted to the pump must not be modified in any way except for shortening to a specific application. Any splice between the pump and the control panel must be made in accordance with all applicable electric codes. It is recommended that a junction box (if used) with seal fittings be mounted outside the sump or be of at least Nema 7 (EEMAC-7) explosion proof construction with seal fittings if located within the wet well. A UL listed seal fitting **MUST** be used in conduit leaving the hazardous location. **DO NOT USE THE POWER OR CONTROL CORDS TO LIFT PUMP.**

C-4.2) Wire Size:

If additional cable is required consult a qualified electrician for proper wire size. See table for further electrical information.



WARRANTY NOTE:

Both the temperature sensor and moisture detection system must be connected to the motor circuitry such that the motor will be de-energized or sound alarm if excessive motor temperatures are reached and/or if water is detected in the seal chamber and/or motor chamber. Failure to have the above mentioned systems installed and operative, nullifies warranty.

C-4.3) Overload Protection:

The normally closed (N/C) thermal sensor is embedded in the motor windings and will detect excessive heat in the event an overload condition occurs which will then trip and stop the pump. The thermal sensor leads marked P1 and P2 **MUST** be connected in series with the stop button of the pilot circuit of the magnetic motor controller located in the control panel so that the thermostat will open the circuit before dangerous temperatures are reached. A manual momentary start switch is required to prevent the automatic restarting of the motor when the thermostat resets. For a typical wiring diagram, refer to Figure 3.

In the event of an overload, the source of this condition should be determined and rectified before the pump is put back into normal operation. **DO NOT LET THE PUMP CYCLE OR RUN IF AN OVERLOAD CONDITION OCCURS !**

If current through the temperature sensor exceeds the values listed, an intermediate control circuit relay must be used to reduce the current or the sensor will not work properly.

TEMPERATURE SENSOR ELECTRICAL RATINGS		
Volts	Continuous Amperes	Inrush Amperes
110-120	3.00	30.0
220-240	1.50	15.0
440-480	0.75	7.5

MODEL NO	PART NO	"A" DIM	HP	VOLT/ Ph	Hz	RPM (Nom)	NEMA START CODE	FULL LOAD AMPS	LOCKED ROTOR AMPS	CORD SIZE	CORD TYPE	CORD O.D. ± .02 (.5) in (mm)	WINDING RESISTANCE
4XSE3026A	084714	39.09	3.0	230/1	60	1150	J	21.0	86.0	10/4	SOW	0.735 (19)	2.97
4XSE3036A	084715	33.31	3.0	230/3	60	1150	H	9.6	52.4	14/4	SOW	0.590 (15)	1.50
4XSE3046A	084716	33.31	3.0	460/3	60	1150	H	4.8	26.2	14/4	SOW	0.590 (15)	6.03
4XSE3056A	089318	33.31	3.0	575/3	60	1150	H	3.8	21.0	14/4	SOW	0.590 (15)	9.50
4XSE5036A	084717	33.31	5.0	230/3	60	1150	G	15.2	76.6	12/4	SOW	0.675 (17)	1.02
4XSE5046A	084718	33.31	5.0	460/3	60	1150	G	7.6	38.3	12/4	SOW	0.675 (17)	4.11
4XSE5056A	089319	33.31	5.0	575/3	60	1150	G	6.0	30.6	14/4	SOW	0.590 (15)	6.46
4XSE7536A	084719	39.09	7.5	230/3	60	1150	G	23.0	115.6	10/4	SOW	0.735 (19)	0.54
4XSE7546A	084720	39.09	7.5	460/3	60	1150	G	11.5	57.8	10/4	SOW	0.735 (19)	2.17
4XSE7556A	089320	39.09	7.5	575/3	60	1150	G	9.2	46.2	6/4	SOW	1.125 (29)	3.39

MODEL NO	PART NO	"A" DIM	HP	VOLT/ Ph	Hz	RPM (Nom)	NEMA START CODE	FULL LOAD AMPS	LOCKED ROTOR AMPS	CORD SIZE	CORD TYPE	CORD O.D. ± .02 (.5) in (mm)	WINDING RESISTANCE
4XSE5024A	084721	39.09	5.0	230/1	60	1750	H	30.0	146.0	8/4	SOW	0.985 (25)	1.02
4XSE5034A	084722	33.31	5.0	230/3	60	1750	H	14.8	85.4	12/4	SOW	0.675 (17)	4.11
4XSE5044A	084723	33.31	5.0	460/3	60	1750	H	7.4	42.7	12/4	SOW	0.675 (17)	1.02
4XSE5054A	089324	33.31	5.0	575/3	60	1750	H	5.9	34.1	12/4	SOW	0.675 (17)	5.75
4XSE7534A	084724	33.31	7.5	230/3	60	1750	H	21.0	130.0	10/4	SOW	0.735 (19)	0.54
4XSE7544A	084725	33.31	7.5	460/3	60	1750	H	10.5	65.0	10/4	SOW	0.735 (19)	2.18
4XSE7554A	089325	33.31	7.5	575/3	60	1750	H	8.4	52.0	10/4	SOW	0.735 (19)	3.36
4XSE10034A	084726	39.09	10	230/3	60	1750	H	27.0	160.0	8/4	SOW	0.985 (25)	0.36
4XSE10044A	084727	39.09	10	460/3	60	1750	H	13.5	80.0	8/4	SOW	0.985 (25)	1.47
4XSE10054A	089326	39.09	10	575/3	60	1750	H	10.8	64.0	8/4	SOW	0.985 (25)	2.29
4XSE15034A	084728	39.09	15	230/3	60	1750	G	42.0	222.0	8/4	SOW	0.985 (25)	0.21
4XSE15044A	084729	39.09	15	460/3	60	1750	G	21.0	111.0	8/4	SOW	0.985 (25)	0.85
4XSE15054A	089327	39.09	15	575/3	60	1750	G	16.8	88.8	8/4	SOW	0.985 (25)	1.35
4XSE20034A	084730	39.09	20	230/3	60	1750	G	56.0	298.0	6/4	SOW	1.125 (29)	0.17
4XSE20044A	084731	39.09	20	460/3	60	1750	G	28.0	149.0	6/4	SOW	1.125 (29)	0.71
4XSE20054A	089328	39.09	20	575/3	60	1750	G	22.4	119.0	6/4	SOW	1.125 (29)	1.06

MODEL NO	PART NO	"A" DIM	HP	VOLT/ Ph	Hz	RPM (Nom)	NEMA START CODE	FULL LOAD AMPS	LOCKED ROTOR AMPS	CORD SIZE	CORD TYPE	CORD O.D. ± .02 (.5) in (mm)	WINDING RESISTANCE
4XSE3036HA	084732	38.92	3.0	230/1	60	1150	J	21.0	86.0	10/4	SOW	0.735 (19)	2.97
4XSE3036HA	084733	33.18	3.0	230/3	60	1150	H	9.6	52.4	14/4	SOW	0.590 (15)	1.50
4XSE3046HA	084734	33.18	3.0	460/3	60	1150	H	4.8	26.2	14/4	SOW	0.590 (15)	6.03
4XSE5036HA	084735	33.18	5.0	230/3	60	1150	G	15.2	76.6	12/4	SOW	0.675 (17)	1.02
4XSE5046HA	084736	33.18	5.0	460/3	60	1150	G	7.6	38.3	12/4	SOW	0.675 (17)	4.11
4XSE7536HA	084737	38.92	7.5	230/3	60	1150	G	23.0	115.6	10/4	SOW	0.735 (19)	0.54
4XSE7546HA	084738	38.92	7.5	460/3	60	1150	G	11.5	57.8	10/4	SOW	0.735 (19)	2.17
4XSE7534HA	084739	33.18	7.5	230/3	60	1750	H	21.0	130.0	10/4	SOW	0.735 (19)	0.54
4XSE7544HA	084740	33.18	7.5	460/3	60	1750	H	10.5	65.0	10/4	SOW	0.735 (19)	2.18
4XSE10034HA	084741	38.92	10	230/3	60	1750	H	27.0	160.0	8/4	SOW	0.985 (25)	0.36
4XSE10044HA	084742	38.92	10	460/3	60	1750	H	13.5	80.0	8/4	SOW	0.985 (25)	1.47
4XSE15034HA	084743	38.92	15	230/3	60	1750	G	42.0	222.0	8/4	SOW	0.985 (25)	0.21
4XSE15044HA	084744	38.92	15	460/3	60	1750	G	21.0	111.0	8/4	SOW	0.985 (25)	0.85

Moisture and Temperature sensor cord for all models is 18/5 SOW, 0.485 (12.4mm) ± .02 (.51mm) O.D.

Winding Resistance ± 5% Winding resistance measured in OHMS @ 25°C (Between Lines)

Pump rated for operation at ± 10% voltage at motor.

SINGLE PHASE 200/230 VOLT AC	
Power Cable	Motor Lead Number
Green (Ground)	Green
Black	1
Red	5
White	4 & 8

THREE PHASE 480-600 VOLT AC	
Power Cable	Motor Lead Number
Green (Ground)	Green
Black	1
Red	3
White	2
	T4 & T7 Together
	T5 & T8 Together
	T6 & T9 Together

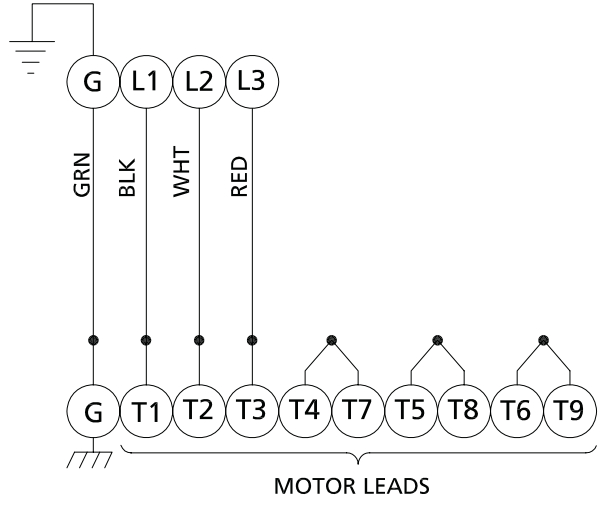
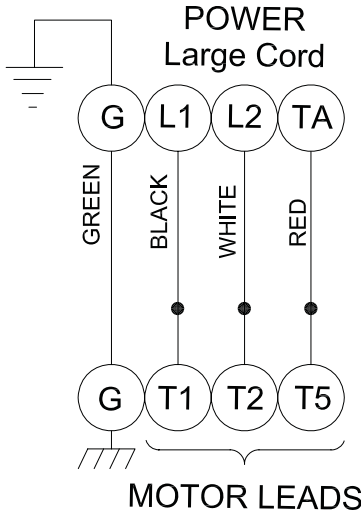

THREE PHASE 200-230 VOLT AC	
Power Cable	Motor Lead Number
Green (Ground)	Green
Black	1 & 7
Red	3 & 9
White	2 & 8
	T4, T5 & T6 Together

MOISTURE AND TEMPERATURE SENSORS	
Control Cable	Lead Number
Green (Ground)	Green
Black	P1 (Temperature Sensor)
White	P2 (Temperature Sensor)
Red	W1 (Moisture Sensor)
Orange	W2 (Moisture Sensor)

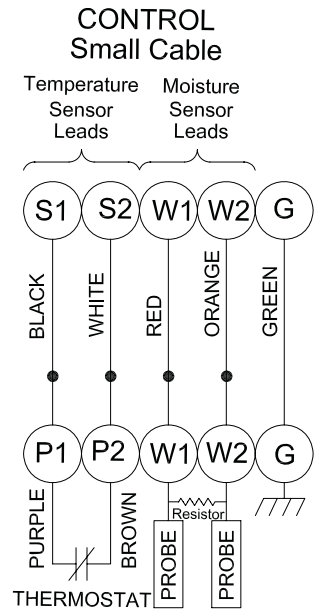
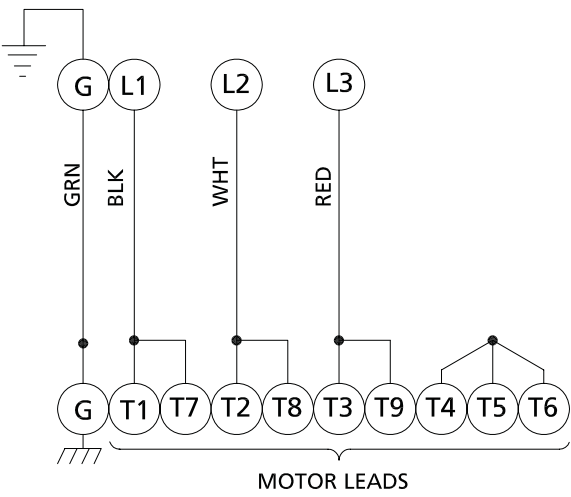
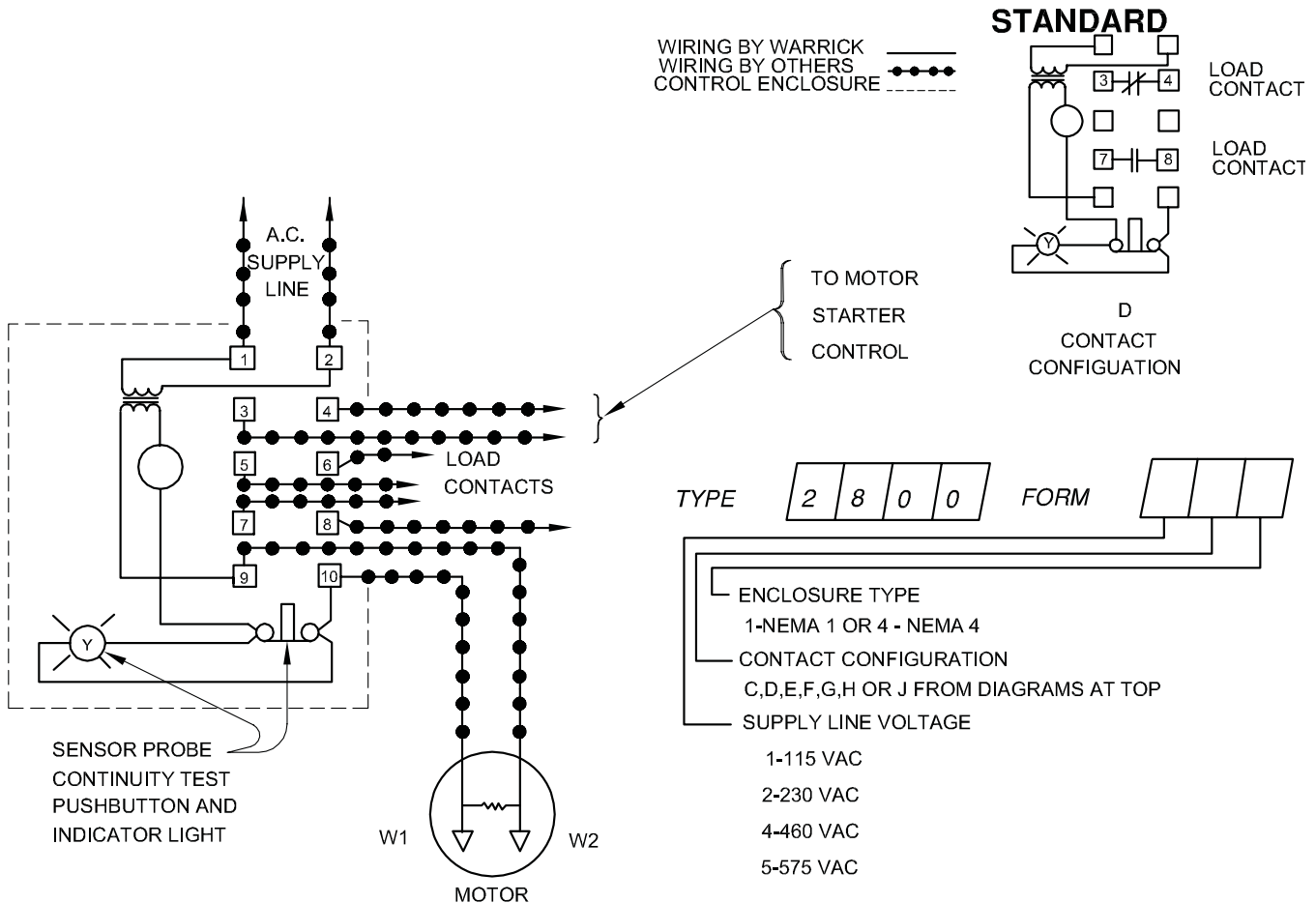
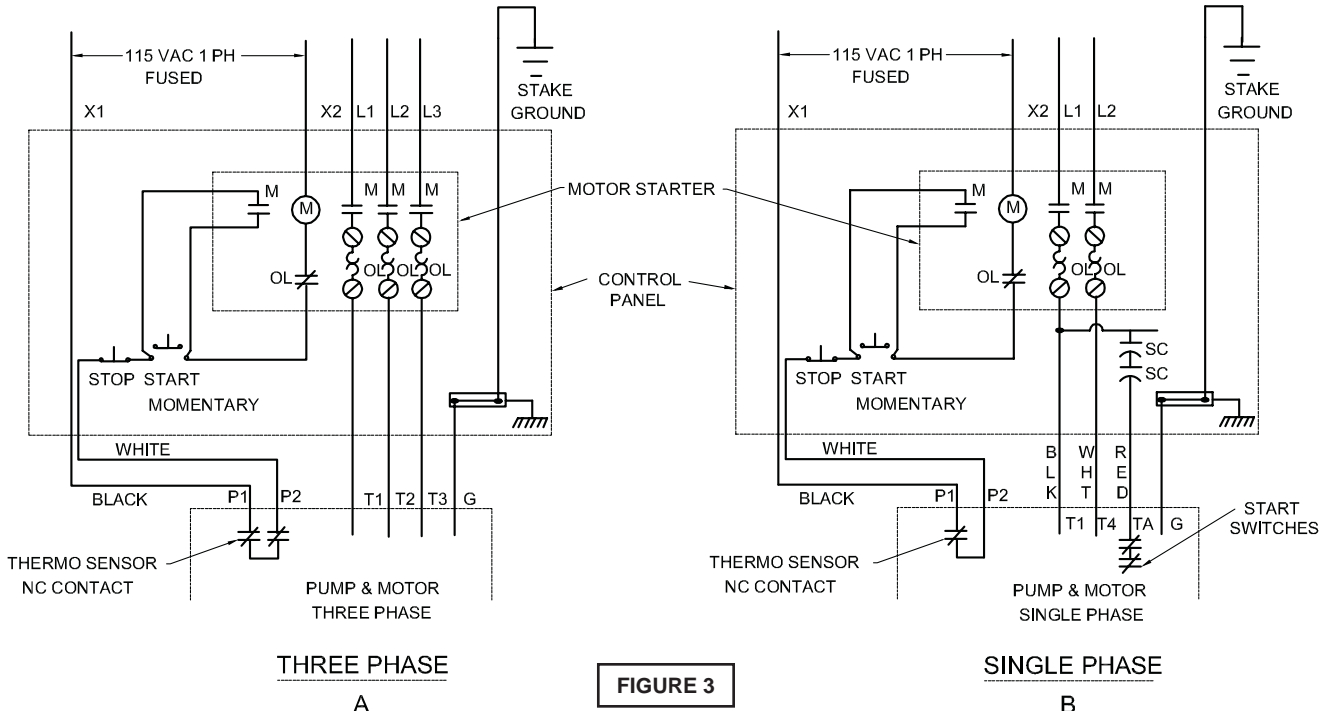

FIGURE 2

TYPICAL THERMAL PROTECTION WIRING DIAGRAM



C-4.4) Moisture Sensors:

A normally open (N/O) detector is installed in the pump seal chamber, which will detect any moisture present, and a continuity test resistor built into the motor. The test resistor is rated 1 watt at 330K ohms. The moisture sensors **MUST** be connected to moisture detector control, which includes a continuity test circuit, see Figure 4 for typical wiring diagram. The normally closed (N/C) contact of the moisture detector **MUST** be connected in series with the stop button of the pilot circuit of the magnetic motor controller. A Warrick moisture detection control, Type 2800 is an acceptable control if properly installed and maintained. Wiring must be provided from the moisture detector sensor probe leads of the motor designated W1 and W2 to terminals 9 and 10 of the 2800-XXX control. Terminal pair 1-2 must be continuously energized from an A-C supply line of electrical characteristics shown on the data table. In the event of moisture detection, the pump should be pulled and the source of the failure located and repaired. **IF MOISTURE DETECTION HAS OCCURRED, SCHEDULE MAINTENANCE AS SOON AS POSSIBLE !**

C-4.6) Control Panel and Electrical System:

The control panel and the electrical system **MUST** be properly designed and wired to include at least, but not limited to the following;

- a. Proper grounding per NEC.
- b. A temperature sensing circuit (see Fig. 3A & B)
- c. A moisture detection circuit with continuity test circuit (see Figure 4)
- d. An intrinsically safe level control system.
- e. A main power manual disconnect and lock out.
- f. A motor starter and overload system.
- g. Single phase only, requires a capacitor power pack (see Figure 3B).

Control panels for single phase pumps **MUST** be purchased from the factory and it is advisable that all three phase control panels are also purchased from the factory.

SECTION: D START-UP OPERATION

D-1) Check Voltage and Phase:

Before operating pump, compare the voltage and phase information stamped on the pump's identification plate to the available power.

D-2) Check Pump Rotation:

Before putting pump into service for the first time, the motor rotation must be checked. Improper motor rotation can result in poor pump performance and can damage the motor and/or pump. To check the rotation, suspend the pump freely, momentarily apply power and observe the "kickback". "Kickback" should always be in a counter-clockwise direction as viewed from the top of the pump motor housing.

D-2.1) Incorrect Rotation for Three-Phase Pumps:

In the event that the rotation is incorrect for a three-phase installation, interchange any two power cable leads at the control box. **DO NOT** change leads in the cable housing in the motor. Recheck the "kickback" rotation again by momentarily applying power.

D-2.2) Incorrect Rotation for Single-Phase Pumps:

In the unlikely event that the rotation is incorrect for a single phase pump, contact a Barnes Service Center.

D-2.3) Test Procedure For Moisture Sensor Control:

With a Warrick moisture detection control, type 2800, a normally closed push button and neon indicating lamp is provided as a means of checking the moisture sensing components. When the push button is depressed, the indicating lamp will be illuminated to indicate (A) power is supplied to the control, (B) the control is operative, and (C) wiring to the moisture sensing probes in the motor is intact. This procedure should be performed periodically to confirm integrity of the circuit.

D-3) Start-Up Report:

Included at the end of this manual are two start-up report sheets, these sheets are to be completed as applicable. Return one copy to Barnes and store the second in the control panel or with the pump manual if no control panel is used. It is important to record this data at initial start-up since it will be useful to refer to should servicing the pump be required in the future.

D-3.1) Identification Plate:

Record the numbers from the pump's identification plate on both START-UP REPORTS provided at the end of the manual for future reference.

D-3.2) Insulation Test:

Before the pump is put into service, an insulation (megger) test should be performed on the motor. The resistance values (ohms) as well as the voltage (volts) and current (amps) should be recorded on the start-up report.

D-3.3) Pump-Down Test:

After the pump has been properly wired and lowered into the basin, sump or lift station, it is advisable to check the system by filling with liquid and allowing the pump to operate through it's pumping cycle. The time needed to empty the system, or pump-down time along with the volume of water, should be recorded on the start-up report.

SECTION E: PREVENTATIVE MAINTENANCE

As the motor is Air-filled, no lubrication or other maintenance is required, and generally Barnes Pumps will give very reliable service and can be expected to operate for years of normal sewage pumping without failing. However, as with any mechanical piece of equipment a preventive maintenance program is recommended and suggested to include the following checks:

- 1) Test moisture detector control "Test Switch" for continuity of circuit. Water in the seal chamber will energize a seal leak warning light at the control panel. This is a warning light only and does not stop the motor. It indicates the seal has leaked and must be repaired. This should be done within 2 or 3 weeks to prevent further damage. See section D-2.3.
- 2) Inspect impeller and body for excessive build-up or clogging and repair as required per section F-1.
- 3) Inspect outer shaft seal and replace as required per section F-2.
- 4) Check motor for ground leakage and proper amp draw. Motor and inner seal repair per section F-3.

SECTION F: SERVICE AND REPAIR

NOTE: All item numbers in () refer to Figures 8 & 9.

WARNING ! - Electrical power to the pump motors must be disconnected and locked out to prevent any dangerous electrical hazards or personnel danger before any service work is done to the pump.

CAUTION ! - Operating pump builds up heat and pressure; allow time for pump to cool to room temperature before handling or servicing.

F-1) Impeller and Volute Service:
F-1.1) Disassembly and Inspection:

To clean out the volute (1), on Standard, (1A) on High Efficiency models, clean out or replace impeller (7), or replace wear ring (1B) on High Efficiency, disconnect power, remove cap screws (3) and lockwashers (4) then vertically lift motor assembly from the pump body (1) or (1A). Clean out the volute, if necessary, examine wear ring (1B) on High Efficiency models and replace if worn. If wear ring (1B) requires replacing, split the wear ring (1B) and remove, be careful not to damage the volute (1A). Clean and examine impeller (7) for pitting or wear, replace if required.

To remove Impeller (7) on Standard models, remove cap screw (20) and washer (10), on High Efficiency models, remove cap screw (3) and spacer (10). The impeller is keyed onto the shaft with a square key (6) and to remove, pull impeller straight off the shaft using a wheel puller if required. Inspect gasket (5) and replace if cut or damaged. Before reinstallation, check the motor shaft and impeller bore for damage.

F-1.2) Reassembly:

On High Efficiency models install wear ring (1B) first, apply retaining compound to bore of volute (1A) and then press wear ring (1B) into bore of volute (1a) until seated. To install impeller (7) on Standard models, first locate spacer (9) on shaft along with shims (19) be sure to use the same quantity as removed. On High Efficiency models, first locate spacer (9) on shaft, then apply a thin film of oil to motor shaft and slide impeller straight onto shaft, keeping keyways lined up. Drive key (6) into keyway. Locate washer (10) STD, or spacer (10) High Eff., on shaft, apply thread locking compound to cap screw (20) STD, or (3) High Eff., thread cap screw (20) or (3) into shaft and torque to 35 ft. lbs. Rotate impeller to check for binding.

Lay gasket (5) on volute (1) STD, or (1A) High Eff., lining up holes and install impeller and motor assembly onto volute (1) STD, or (1A) High Eff. Locate washers (4) on cap screws (3) and apply thread locking compound to threads of each cap screw (3), insert into volute and motor assembly and torque to 20 ft. lbs. Check for free rotation of motor and impeller.

F-2) Outer Shaft Seal Service:

CAUTION ! - Handle seal parts with extreme care. DO NOT scratch or mar lapped surfaces.

F-2.1) Disassembly and Inspection:

To expose outer shaft seal (13) for examination, remove Impeller and Volute per Section F-1.1. To disassemble adapter (11) and gasket (5) from motor (2), remove socket head cap screws (18) and lockwashers (4). Set motor assembly (2) in the up position to prevent loss of oil. Remove snap ring from motor shaft, then retaining ring (13D), spring (13C) and rotating member (13B) from shaft, See Figure 5. Examine all seal parts and especially contact faces. Inspect seal for signs of wear such as uneven wear pattern on stationary members, chips and scratches on either seal face. **DO NOT** interchange seal components, replace the entire shaft seal (13). If replacing seal, remove stationary (13A) from mounting plate by prying out with flat screw driver.

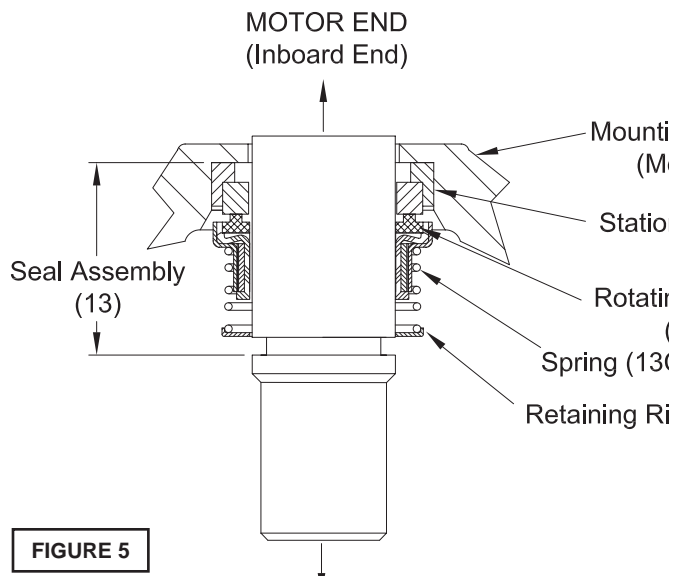

FIGURE 5

F-2.2) Reassembly:

Lightly oil (**DO NOT use grease**) outer surface of stationary member (13A). Press stationary member (13A) firmly into mounting plate using a seal pusher, nothing but the seal pusher is to come in contact with seal face (see Figure 6).

IMPORTANT ! - DO NOT hammer on the seal pusher- it will damage the seal face.

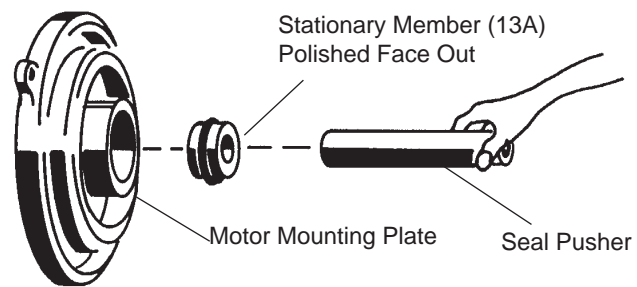

FIGURE 6

Make sure the stationary member is in straight and that the rubber ring is not out of its groove. Lightly oil (**DO NOT use grease**) shaft and inner surface of bellows on rotating member (13B) see Figure 7. With lapped surface of rotating member (13B) facing inward toward stationary member (13A), slide rotating member (13B) onto shaft using a seal pusher, until lapped faces of (13A) and (13B) are together. (see Figure 5).

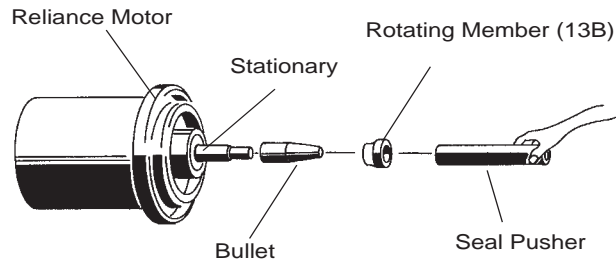

FIGURE 7

! IMPORTANT ! - It is extremely important to keep seal faces clean during assembly. dirt particles lodged between these faces will cause the seal to leak.

Place spring (13C) over shaft and in place on rotating member (13B), making sure it is seated on retainer and not cocked or resting on bellows tail. Slide retaining ring (13B) over shaft and let rest on spring (13C). Replace snap ring onto motor shaft. Inspect gasket (5) and replace if cut or damaged. Place adapter (11) on motor (2) and insert socket head cap screws (18) and lockwashers (4) and tighten. Assemble impeller and volute as outlined in paragraph F-1.2.

F-3) Motor & Inner Shaft Seal Service

The XSE Submersible Pump motor is manufactured by Reliance Electric Co. and must be serviced and repaired by Reliance approved service centers only.

For lead reconnection information, contact Reliance Electric Co., giving motor serial number.

! WARNING ! - These motors are u/l listed for application in CLASS I, GROUPS C & D EXPLOSION PROOF ENVIRONMENTS. All repairs, other than lead reconnects and outer seal replacement, shall be performed by an authorized reliance service facility. Any other repairs performed by the customer or NON-RELIANCE Service Facilities NEGATES the U/L Listing and motor warranty.

SECTION: G REPLACEMENT PARTS

G-1 ORDERING REPLACEMENT PARTS:

When ordering replacement parts, ALWAYS furnish the following information:

1. Pump serial number and date code. (Paragraph G-4)
2. Pump model number. (Paragraph G-3)
3. Pump part number. (Paragraph G-2)
4. Part description.
5. Item part number.
6. Quantity required.
7. Shipping instructions.
8. Billing Instructions.

BARNES	HP.	Volts	Code	Ph.	Hz.
	RPM	FLA	Model No.	2	
	Part No.	3		Serial No.	1
	Impeller Dia.	Max. Liq. Temp.	°C	Ins. Class	

WARNING TO REDUCE RISK OF ELECTRICAL SHOCK DISCONNECT THE PUMP FROM THE POWER SOURCE BEFORE HANDLING OR SERVICING. SEE INSTRUCTION MANUAL FOR PROPER INSTALLATION. SEE WARNING PLATE FOR ADDITIONAL CAUTIONS.

G-2 PART NUMBER:

The part number consists of a six (6) digit number, which appears in the catalog. A one or two letter suffix may follow this number to designate the design configuration. This number is used for ordering and obtaining information.

G-3 MODEL NUMBER:

This designation consists of numbers and letters which represent the discharge size, series, horsepower, motor phase and voltage, speed and pump design. This number is used for ordering and obtaining information.

G-4 SERIAL NUMBER:

The serial number block will consist of a six digit number, which is specific to each pump and may be preceded by a alpha character, which indicates the plant location. This number will also be suffixed with a four digit number, which indicates the date the unit was built (Date Code). **EXAMPLE: A012345 0490.**

Reference the six digit portion (Serial Number) of this number when referring to the product.

TROUBLE SHOOTING

CAUTION ! Always disconnect the pump from the electrical power source before handling.
 If the system fails to operate properly, carefully read instructions and perform maintenance recommendations.
 If operating problems persist, the following chart may be of assistance in identifying and correcting them:
 MATCH "CAUSE" NUMBER WITH CORRELATING "CORRECTION" NUMBER.

NOTE: Not all problems and corrections will apply to each pump model.

PROBLEM	CAUSE	CORRECTION
Pump will not run	<ol style="list-style-type: none"> 1. Poor electrical connection, blown fuse, tripped breaker or other interruption of power, improper power supply. 2. Motor or switch inoperative (to isolate cause, go to manual operation of pump). <ol style="list-style-type: none"> 2a. Float movement restricted. 2b. Switch will not activate pump or is defective. 2c. Defective motor 3. Insufficient liquid level. 	<ol style="list-style-type: none"> 1. Check all electrical connections for security. Have electrician measure current in motor leads, if current is within $\pm 20\%$ of locked rotor Amps, impeller is probably locked. If current is 0, overload may be tripped. Remove power, allow pump to cool, then recheck current. 2a. Reposition pump or clean basin as required to provide adequate clearance for float. 2b. Disconnect level control. Set ohmmeter for a low range, such as 100 ohms full scale and connect to level control leads. Actuate level control manually and check to see that ohmmeter shows zero ohms for closed switch and full scale for open switch. (Float Switch). 2c. Check winding insulation (Megger Test) and winding resistance. If check is outside of range, dry and recheck. If still defective, replace per service instructions.
Pump will not turn off	<ol style="list-style-type: none"> 2a. Float movement restricted. 2b. Switch will not activate pump or is defective. 4. Excessive inflow or pump not properly sized for application. 9. Pump may be airlocked 14. H-O-A switch on panel is in "HAND" position 	<ol style="list-style-type: none"> 2b. Disconnect level control. Set ohmmeter for a low range, such as 100 ohms full scale and connect to level control leads. Actuate level control manually and check to see that ohmmeter shows zero ohms for closed switch and full scale for open switch. (Float Switch). 2c. Check winding insulation (Megger Test) and winding resistance. If check is outside of range, dry and recheck. If still defective, replace per service instructions.
Pump hums but does not run	<ol style="list-style-type: none"> 1. Incorrect voltage 8. Impeller jammed or loose on shaft, worn or damaged, impeller cavity or inlet plugged. 	<ol style="list-style-type: none"> 2c. Check winding insulation (Megger Test) and winding resistance. If check is outside of range, dry and recheck. If still defective, replace per service instructions.
Pump delivers insufficient capacity	<ol style="list-style-type: none"> 1. Incorrect voltage. 4. Excessive inflow or pump not properly sized for application. 5. Discharge restricted. 6. Check valve stuck closed or installed backwards. 7. Shut-off valve closed. 8. Impeller jammed or loose on shaft, worn or damaged, impeller cavity or inlet plugged. 9. Pump may be airlocked. 10. Pump running backwards 	<ol style="list-style-type: none"> 3. Make sure liquid level is at least equal to suggested turn-on point. 4. Recheck all sizing calculations to determine proper pump size. 5. Check discharge line for restrictions, including ice if line passes through or into cold areas. 6. Remove and examine check valve for proper installation and freedom of operation. 7. Open valve.
Pump cycles too frequently or runs periodically when fixtures are not in use	<ol style="list-style-type: none"> 6. Check valve stuck closed or installed backwards. 11. Fixtures are leaking. 15. Ground water entering basin. 	<ol style="list-style-type: none"> 8. Check impeller for freedom of operation, security and condition. Clean impeller and inlet of any obstruction. 9. Loosen union slightly to allow trapped air to escape. Verify that turn-off level of switch is set so that the suction is always flooded. Clean vent hole.
Pump shuts off and turns on independent of switch, (trips thermal overload protector). CAUTION! Pump may start unexpectedly. Disconnect power supply.	<ol style="list-style-type: none"> 1. Incorrect voltage. 4. Excessive inflow or pump not properly sized for application. 8. Impeller jammed, loose on shaft, worn or damaged, impeller cavity or inlet plugged. 12. Excessive water temperature. (internal protection only) 	<ol style="list-style-type: none"> 10. Check rotation. If power supply is three phase, reverse any two of three power supply leads to ensure proper impeller rotation.. 11. Repair fixtures as required to eliminate leakage.
Pump operates noisily or vibrates excessively	<ol style="list-style-type: none"> 2c. Worn bearings, motor shaft bent. 5. Debris in impeller cavity or broken impeller 10. Pump running backwards 13. Piping attachments to building structure too rigid or too loose. 	<ol style="list-style-type: none"> 12. Check pump temperature limits & fluid temperature. 13. Replace portion of discharge pipe with flexible connector. 14. Turn to automatic position. 15. Check for leaks around basin inlet and outlets.

4XSE-A Standard Pump Series

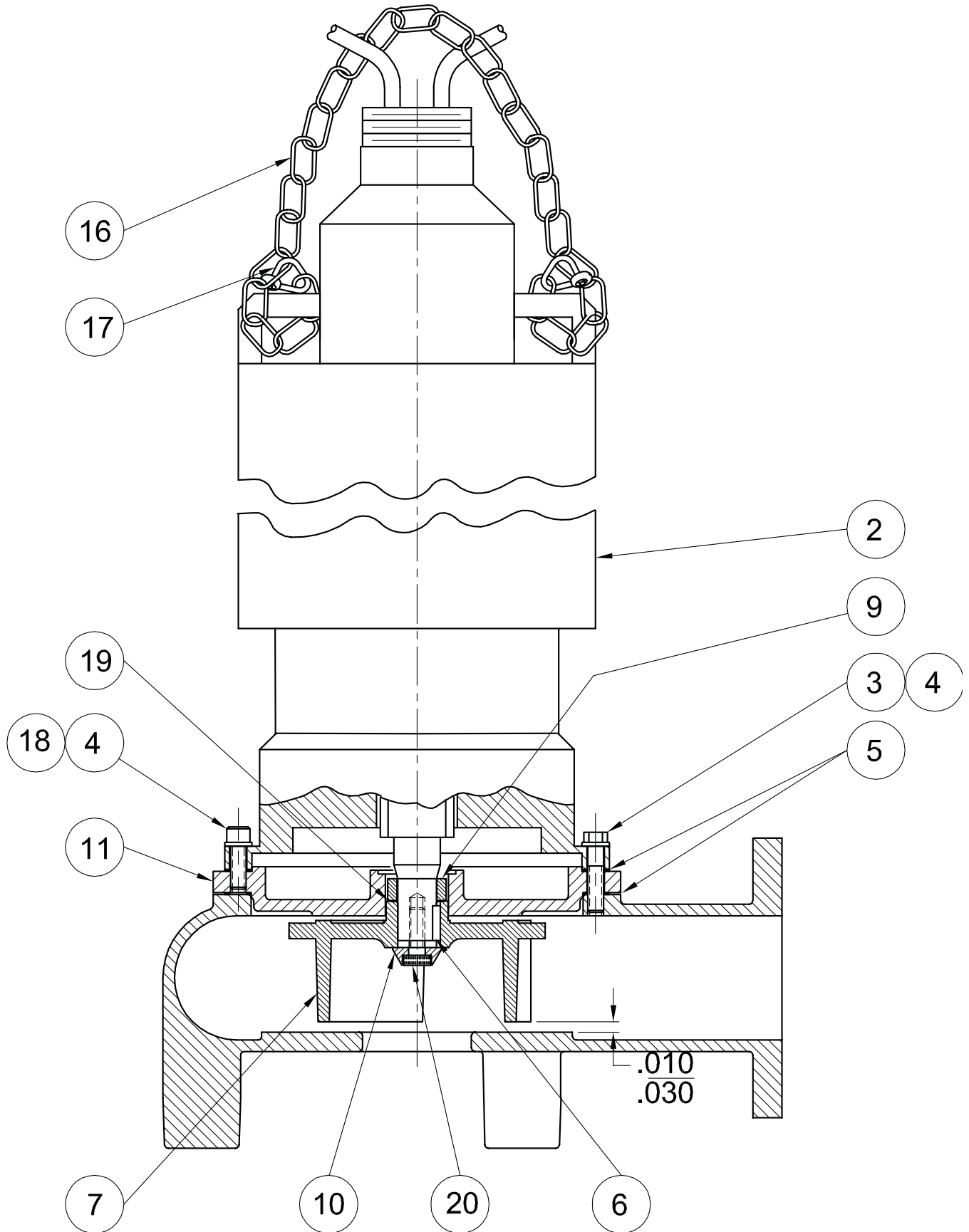

FIGURE 8

4XSE-A Standard Pump Series

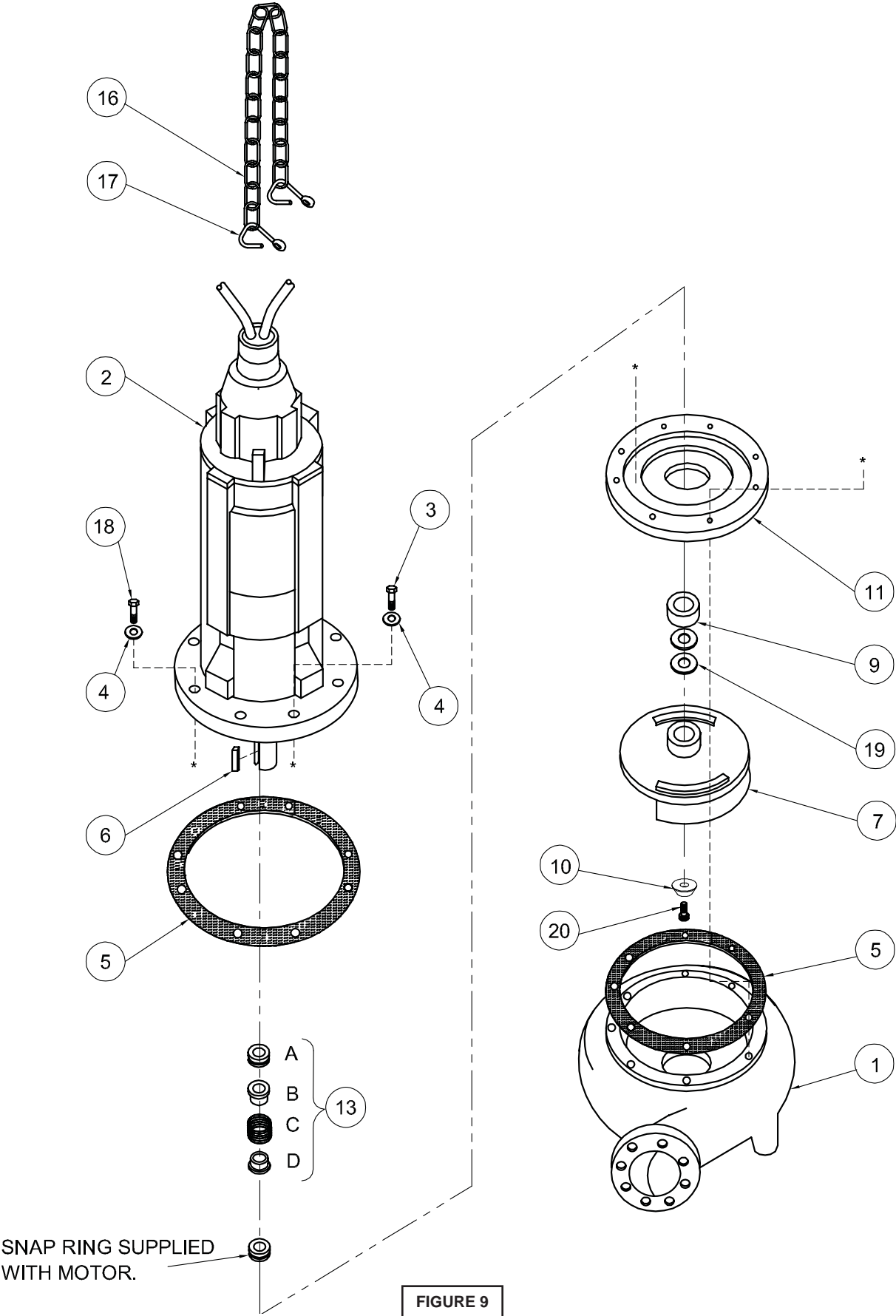

FIGURE 9

4XSE-A Standard Pump Series

PARTS LIST

ITEM	QTY	PART NO.	DESCRIPTION
1	1	069581	Volute
2	1	See Table 1	Motor (See Note: 1)
3	6	1-73-1	Cap Screw, Hex Hd 1/2-13 x 2-1/4" Lg Stainless
4	8	021077	Washer 1/2 Stainless
5	2	069755	Gasket
6	1	051467	Key 1/4 Sq x 1.25" Lg Stainless
7	1	See Table 3-A	Impeller, Cast Iron
9	1	069599	Spacer
10	1	4587-SS	Impeller Washer .531 x 1.562 Stainless
11	1	069582	Adapter
13	1	180TY 071563 071558	Outer Seal (See Note: 2), Carbon/Ceramic/Buna-N (STD) Tungsten/Carbide/Buna-N (Pump End ONLY)
		210TY 071556 071559	Outer Seal (See Note: 2) Carbon/Ceramic/Buna-N (STD)
16	4Ft.	625-01584	Chain .250, Steel
17	3	625-00830	Cold Shut .312, ZP
18	2	069579	Cap Screw, Soc Hd. 1/2-13 x 1-1/2" Lg., Stainless
19	3	025015	Shim .01 Thk Stainless
20	1	11-102-1	SkHd Screw 5/8-11 x 1-1/2" Lg., 18-8 Stainless

PUMP MODEL	MOTOR FRAME SIZE	TABLE 1 MOTOR WITH VARIOUS CORD LENGTHS (Item #2)					
		25Ft (STD)	30Ft.	40Ft.	50Ft.	75Ft.	100Ft.
4XSE3026A	210TY	069592	069592XC	069592XE	069592XF	069592XH	069592XL
4XSE3036A	180TY	069593	069593XC	069593XE	069593XF	069593XH	069593XL
4XSE3046A	180TY	069594	069594XC	069594XE	069594XF	069594XH	069594XL
4XSE3056A	180TY	092851	092851XC	092851XE	092851XF	092851XH	092851XL
4XSE5036A	180TY	069595	069595XC	069595XE	069595XF	069595XH	069595XL
4XSE5046A	180TY	069596	069596XC	069596XE	069596XF	069596XH	069596XL
4XSE5056A	180TY	092850	092850XC	092850XE	092850XF	092850XH	092850XL
4XSE7536A	210TY	069597	069597XC	069597XE	069597XF	069597XH	069597XL
4XSE7546A	210TY	069598	069598XC	069598XE	069598XF	069598XH	069598XL
4XSE7556A	210TY	092848	092848XC	092848XE	092848XF	092848XH	092848XL
4XSE5024A	210TY	069560	069560XC	069560XE	069560XF	069560XH	069560XL
4XSE5034A	180TY	069554	069554XC	069554XE	069554XF	069554XH	069554XL
4XSE5044A	180TY	069555	069555XC	069555XE	069555XF	069555XH	069555XL
4XSE5054A	180TY	092847	092847XC	092847XE	092847XF	092847XH	092847XL
4XSE7534A	180TY	069556	069556XC	069556XE	069556XF	069556XH	069556XL
4XSE7544A	180TY	069557	069557XC	069557XE	069557XF	069557XH	069557XL
4XSE7554A	180TY	092846	092846XC	092846XE	092846XF	092846XH	092846XL
4XSE10034A	210TY	069558	069558XC	069558XE	069558XF	069558XH	069558XL
4XSE10044A	210TY	069559	069559XC	069559XE	069559XF	069559XH	069559XL
4XSE10054A	210TY	092849	092849XC	092849XE	092849XF	092849XH	092849XL
4XSE15034A	210TY	069575	069575XC	069575XE	069575XF	069575XH	069575XL
4XSE15044A	210TY	069576	069576XC	069576XE	069576XF	069576XH	069576XL
4XSE15054A	210TY	092844	092844XC	092844XE	092844XF	092844XH	092844XL
4XSE20034A	210TY	069577	069577XC	069577XE	069577XF	069577XH	069577XL
4XSE20044A	210TY	069578	069578XC	069578XE	069578XF	069578XH	069578XL
4XSE20054A	210TY	092843	092843XC	092843XE	092843XF	092843XH	092843XL

Note: 1 - Standard Motor includes, 25 foot Power & Control cables, Moisture & Temperature Sensors and Carbon/Ceramic/Buna-N Inner & Outer shaft seals.

Note: 2 - When ordering motor (Item 2) Outer seal is supplied. Item 13 is for Outer seal replacement **ONLY**. When ordering outer shaft seal furnish Reliance Motor Serial Number.

4XSE-HA High Efficiency Pump Series

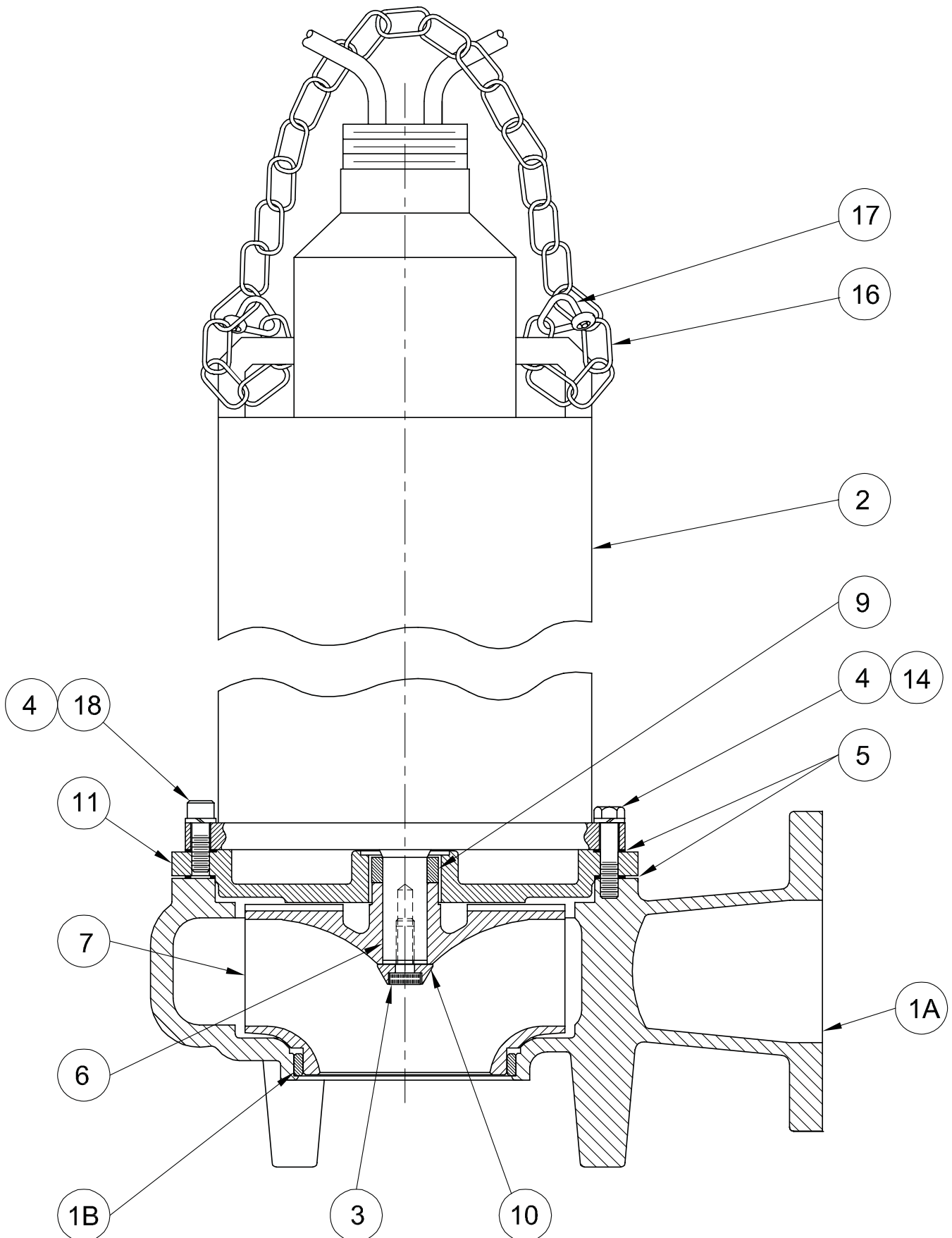

FIGURE 10

4XSE-HA High Efficiency Pump Series

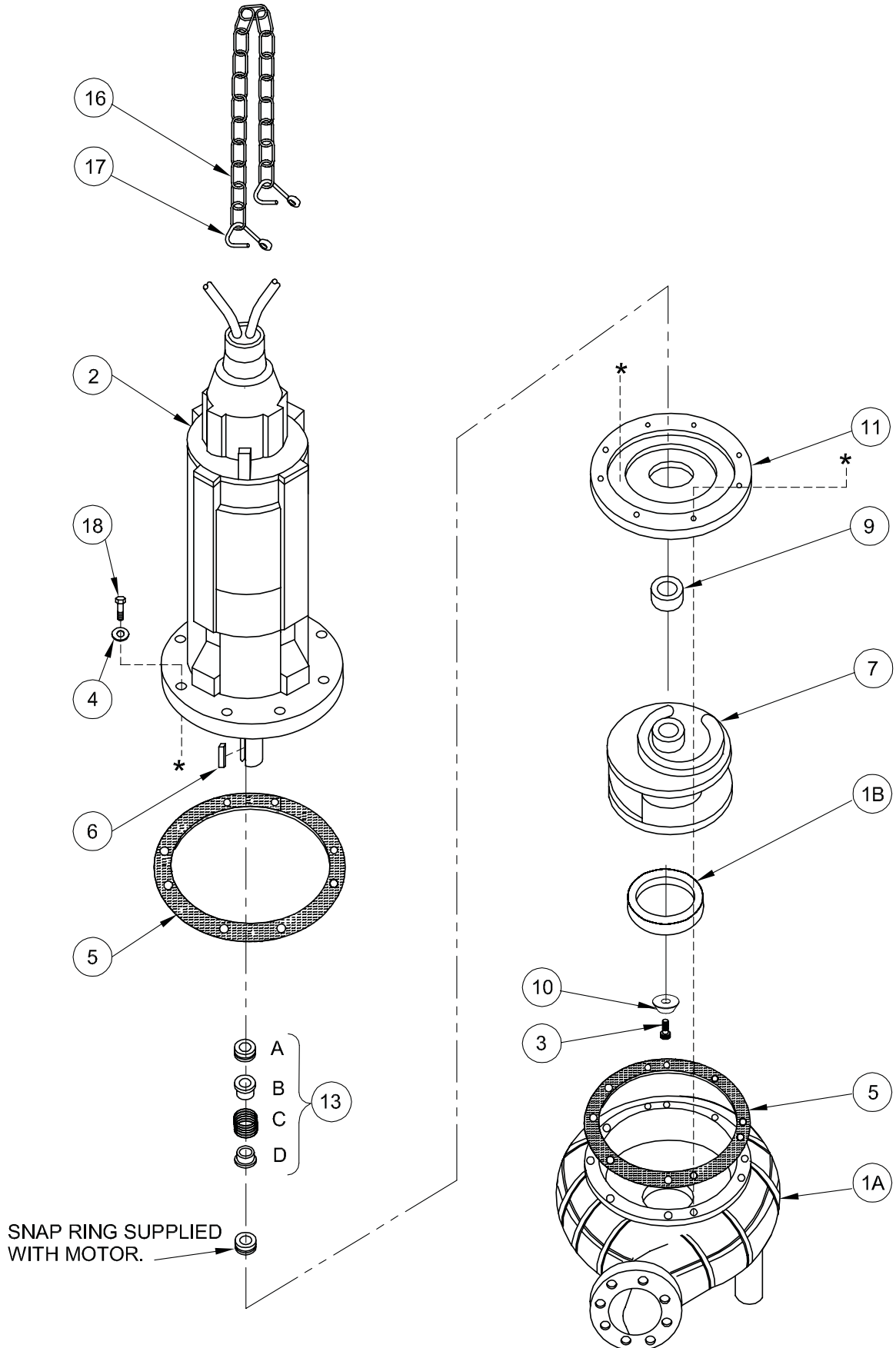

FIGURE 11

4XSE-HA High Efficiency Pump Series

PARTS LIST

ITEM	QTY	PART NO.	DESCRIPTION
1	1	084497	Volute Assembly
1A	1	082213	Volute
1B	1	082083	Wear Ring
2	1	See Table 2	Motor (See Note: 1)
3	6	11-81-1	SkHd Screw 1/2-13 x 2-1/4" Lg., 18-8 Stainless
4	8	021077	Washer 1/2 Stainless
5	2	069755	Gasket
6	1	051467	Key 1/4 Sq x 1.25" Lg Stainless
7	1	See Table 3-B	Impeller, Cast Iron
9	1	069599	Spacer
10	1	4587-SS	Impeller Washer .531 x 1.562 Stainless
11	1	069582	Adapter
13	1	180TY 071563 071558	Outer Seal (See Note: 2), Carbon/Ceramic/Buna-N (STD) Tungsten/Carbide/Buna-N (Pump End ONLY)
		210TY 071556 071559	Outer Seal (See Note: 2) Carbon/Ceramic/Buna-N (STD) Tungsten/Carbide/Buna-N (Pump End ONLY)
14	6	1-73-1	HxHd Cap Screw 1/2-13 x 2.25" Lg., Stainless
16	4Ft.	625-01584	Chain .250, Steel
17	3	625-00830	Cold Shut .312, ZP
18	2	069579	Cap Screw, Soc Hd. 1/2-13 x 1-1/2" Lg., Stainless

PUMP MODEL	MOTOR FRAME SIZE	TABLE 2 MOTOR WITH VARIOUS CORD LENGTHS (Item #2)					
		25Ft (STD)	30Ft.	40Ft.	50Ft.	75Ft.	100Ft.
4XSE3026HA	210TY	088256	088256XC	088256XE	088256XF	088256XH	088256XL
4XSE3036HA	180TY	088257	088257XC	088257XE	088257XF	088257XH	088257XL
4XSE3046HA	180TY	088258	088258XC	088258XE	088258XF	088258XH	088258XL
4XSE5036HA	180TY	088259	088259XC	088259XE	088259XF	088259XH	088259XL
4XSE5046HA	180TY	088260	088260XC	088260XE	088260XF	088260XH	088260XL
4XSE7536HA	210TY	088261	088261XC	088261XE	088261XF	088261XH	088261XL
4XSE7546HA	210TY	088262	088262XC	088262XE	088262XF	088262XH	088262XL
4XSE7534HA	180TY	088263	088263XC	088263XE	088263XF	088263XH	088263XL
4XSE7544HA	180TY	088264	088264XC	088264XE	088264XF	088264XH	088264XL
4XSE10034HA	210TY	088265	088265XC	088265XE	088265XF	088265XH	088265XL
4XSE10044HA	210TY	088266	088266XC	088266XE	088266XF	088266XH	088266XL
4XSE15034HA	210TY	088267	088267XC	088267XE	088267XF	088267XH	088267XL
4XSE15044HA	210TY	088268	088268XC	088268XE	088268XF	088268XH	088268XL

Note: 1 - Standard Motor includes, 25 foot Power & Control cables, Moisture & Temperature Sensors and Carbon/Ceramic/Buna-N Inner & Outer shaft seals.

Note: 2 - When ordering motor (Item 2) Outer seal is supplied. Item 13 is for Outer seal replacement **ONLY**. When ordering outer shaft seal furnish Reliance Motor Serial Number.

4XSE-HA High Efficiency Pump Series

TABLE 3 - IMPELLER (Item #7)			
IMPELLER DIAMETER	A - STANDARD MODEL		B - HIGH EFFICIENCY
	1150RPM	1750RPM	1150 & 1750RPM
10.75"	084896	084896	N/A
10.62"	084896TA	084896TA	N/A
10.50"	084896TB	084896TB	N/A
10.38"	084896TC	084896TC	N/A
10.25"	084896TD	084896TD	N/A
10.12"	084896TE	084896TE	N/A
10.00"	084896TF - 7.5HP	084896TF	N/A
9.88"	084892TG	084896TG - 20HP	N/A
9.75"	084892TH	084896TH	N/A
9.62"	084892TJ	084896TJ	N/A
9.50"	084892TK	084896TK	N/A
9.38"	084892TL	084896TL	N/A
9.25"	084892TM	084896TM	N/A
9.12"	084892TN	084896TN	N/A
9.00"	084892TP - 5HP	084896TP	083607 - 7.5HP, 1150; 15HP, 1750
8.88"	084892TQ	084896TQ	083607TA
8.75"	084892TR	084896TR	083607TB
8.62"	084892TS	084896TS	083607TC
8.50"	084892TT	084896TT - 15HP	083607TD
8.38"	084892TU	084896TU	083607TE
8.25"	084892TV - 3HP	084896TV	083607TF
8.12"	084892TW	084896TW	083607TG
8.00"	084892TX	084896TX	083607TH - 5HP, 1150
7.88"	084892TY	084896TY	083607TJ
7.75"	084892TZ	084896TZ - 10HP	083607TK
7.62"	084892UA	084896UA	083607TL
7.50"	084892UB	084896UB	083607TM - 10HP, 1750
7.38"	084892UC	084896UC	083607TN
7.25"	084892UD	084896UD	083607TP
7.12"	084892UE	084896UE	083607TQ
7.00"	084892UF	084896UF - 7.5HP	083607TR - 7.5HP, 1750
6.88"	084892UG	084896UG	083607TS
6.75"	084892UH	084896UH	083607TT
6.62"	084892UJ	084896UJ	083607TU
6.50"	084892UK	084896UK - 5HP	083607TV - 3HP, 1150
6.38"	084892UL	084896UL	N/A
6.25"	N/A	084896UM	N/A
6.12"	N/A	084896UN	N/A
6.00"	N/A	084896UP	N/A
5.88"	N/A	084896UQ	N/A
5.75"	N/A	084896UR	N/A
5.62"	N/A	084896US	N/A
5.50"	N/A	084896UT	N/A
5.38"	N/A	084896UU	N/A
5.25"	N/A	084896UV	N/A
5.12"	N/A	084896UW	N/A
5.00"	N/A	084896UX	N/A

BARNES®

BARNES®
PRESSURE **PS** SYSTEMS

CROWN

burks®

WEINMAN®

DEMING®

PROSSER®

Limited 24 Month Warranty

Crane Pumps & Systems warrants that products of our manufacture will be free of defects in material and workmanship under normal use and service for twenty-four (24) months after manufacture date, when installed and maintained in accordance with our instructions. This warranty gives you specific legal rights, and there may also be other rights which vary from state to state. In the event the product is covered by the Federal Consumer Product Warranties Law (1) the duration of any implied warranties associated with the product by virtue of said law is limited to the same duration as stated herein, (2) this warranty is a LIMITED WARRANTY, and (3) no claims of any nature whatsoever shall be made against us, until the ultimate consumer, his successor, or assigns, notifies us in writing of the defect, and delivers the product and/or defective part(s) freight prepaid to our factory or nearest authorized service station. Some states do not allow limitations on how long an implied warranty lasts, so the above limitation may not apply. **THE SOLE AND EXCLUSIVE REMEDY FOR BREACH OF ANY AND ALL WARRANTIES WITH RESPECT TO ANY PRODUCT SHALL BE TO REPLACE OR REPAIR AT OUR ELECTION, F.O.B. POINT OF MANUFACTURE OR AUTHORIZED REPAIR STATION, SUCH PRODUCTS AND/OR PARTS AS PROVEN DEFECTIVE. THERE SHALL BE NO FURTHER LIABILITY, WHETHER BASED ON WARRANTY, NEGLIGENCE OR OTHERWISE.** Unless expressly stated otherwise, guarantees in the nature of performance specifications furnished in addition to the foregoing material and workmanship warranties on a product manufactured by us, if any, are subject to laboratory tests corrected for field performance. Any additional guarantees, in the nature of performance specifications must be in writing and such writing must be signed by our authorized representative. Due to inaccuracies in field testing if a conflict arises between the results of field testing conducted by or for user, and laboratory tests corrected for field performance, the latter shall control. **RECOMMENDATIONS FOR SPECIAL APPLICATIONS OR THOSE RESULTING FROM SYSTEMS ANALYSES AND EVALUATIONS WE CONDUCT WILL BE BASED ON OUR BEST AVAILABLE EXPERIENCE AND PUBLISHED INDUSTRY INFORMATION. SUCH RECOMMENDATIONS DO NOT CONSTITUTE A WARRANTY OF SATISFACTORY PERFORMANCE AND NO SUCH WARRANTY IS GIVEN.**

This warranty shall not apply when damage is caused by (a) improper installation, (b) improper voltage (c) lightning (d) excessive sand or other abrasive material (e) scale or corrosion build-up due to excessive chemical content. Any modification of the original equipment will also void the warranty. We will not be responsible for loss, damage or labor cost due to interruption of service caused by defective parts. Neither will we accept charges incurred by others without our prior written approval.

This warranty is void if our inspection reveals the product was used in a manner inconsistent with normal industry practice and/or our specific recommendations. The purchaser is responsible for communication of all necessary information regarding the application and use of the product. **UNDER NO CIRCUMSTANCES WILL WE BE RESPONSIBLE FOR ANY OTHER DIRECT OR CONSEQUENTIAL DAMAGES, INCLUDING BUT NOT LIMITED TO TRAVEL EXPENSES, RENTED EQUIPMENT, OUTSIDE CONTRACTOR FEES, UNAUTHORIZED REPAIR SHOP EXPENSES, LOST PROFITS, LOST INCOME, LABOR CHARGES, DELAYS IN PRODUCTION, IDLE PRODUCTION, WHICH DAMAGES ARE CAUSED BY ANY DEFECTS IN MATERIAL AND/OR WORKMANSHIP AND/OR DAMAGE OR DELAYS IN SHIPMENT. THIS WARRANTY IS EXPRESSLY IN LIEU OF ANY OTHER EXPRESS OR IMPLIED WARRANTY, INCLUDING ANY WARRANTY OF MERCHANTABILITY OR FITNESS FOR A PARTICULAR PURPOSE.**

No rights extended under this warranty shall be assigned to any other person, whether by operation of law or otherwise, without our prior written approval.



A Crane Co. Company

PUMPS & SYSTEMS

420 Third Street
Piqua, Ohio 45356
Phone: (937) 778-8947
Fax: (937) 773-7157
www.cranepumps.com

83 West Drive, Brampton
Ontario, Canada L6T 2J6
Phone: (905) 457-6223
Fax: (905) 457-2650

**IMPORTANT!
WARRANTY REGISTRATION**

Your product is covered by the enclosed Warranty.
To complete the Warranty Registration Form go to:

<http://www.cranepumps.com/ProductRegistration/>

If you have a claim under the provision of the warranty, contact your local
Crane Pumps & Systems, Inc. Distributor.

RETURNED GOODS

**RETURN OF MERCHANDISE REQUIRES A "RETURNED GOODS AUTHORIZATION".
CONTACT YOUR LOCAL CRANE PUMPS & SYSTEMS, INC. DISTRIBUTOR.**



**Products Returned Must Be Cleaned, Sanitized,
Or Decontaminated As Necessary Prior To Shipment,
To Insure That Employees Will Not Be Exposed To Health
Hazards In Handling Said Material. All Applicable Laws
And Regulations Shall Apply.**



A Crane Co. Company

PUMPS & SYSTEMS

START-UP REPORT

General Information

Pump Owner's Name: _____
 Address: _____
 Location of Installation: _____
 Contact Person: _____ Phone: _____
 Purchased From: _____

Nameplate Data

Pump Model #: _____ Serial #: _____
 Part #: _____ Impeller Diameter: _____
 Voltage: _____ Phase: _____ Ø Hertz: _____ Horsepower: _____
 Full Load Amps: _____ Service Factor Amps: _____
 Motor Manufacturer: _____

Controls

Control panel manufacturer: _____
 Model/Part number: _____
 Number of pumps operated by control panel: _____
 Short circuit protection? YES___ NO___ Type: _____
 Number and size of short circuit device(s): _____ Amp rating: _____
 Overload Type: _____ Size: _____ Amp rating: _____
 Do protection devices comply with pump and motor Amp rating? YES___ NO___
 Are all electrical and panel entry connections tight? YES___ NO___
 Is the interior of the panel dry? YES___ NO___
 Liquid level Control Brand and Model: _____

Pre-Startup

All Pumps

Type of equipment: NEW___ REBUILT___ USED___
 Condition of equipment at Start-Up: DRY___ WET___ MUDDY___
 Was Equipment Stored? YES___ NO___ Length of Storage: _____
 Liquid being pumped: _____ Liquid Temperature: _____
 Supply Voltage/Phase/Frequency matches nameplate? YES___ NO___
 Shaft turns freely? YES___ NO___
 Direction of rotation verified for 3Ø motors? YES___ NO___
 Debris in piping or wet well? YES___ NO___
 Debris removed in your presence? YES___ NO___
 Pump case/wet well filled with liquid before startup? YES___ NO___
 Is piping properly supported? YES___ NO___

Non-Submersible Pumps

Is base plate properly installed / grouted? YES___ NO___ N/A___
 Coupling Alignment Verified per I&O Manual? YES___ NO___ N/A___
 Grease Cup/Oil Reservoir Level checked? YES___ NO___ N/A___

Submersible Pumps

Resistance of cable and pump motor (measured at pump control):

Red-Black: _____ Ohms(Ω) Red-White: _____ Ohms(Ω) White-Black: _____ Ohms(Ω)

Resistance of Ground Circuit between Control Panel and outside of pump: _____ Ohms(Ω)

MEG Ohms check of insulation:

Red to Ground: _____ White to Ground: _____ Black to Ground: _____

Operational Checks

Is there noise or vibration present? YES___ NO___ Source of noise/vibration: _____

Does check valve operate properly? YES___ NO___ N/A___

Is system free of leaks? YES___ NO___ Leaks at: _____

Does system appear to operate at design flow rate? YES___ NO___

Nominal Voltage: _____ Phase: 1Ø 3Ø (select one)

Voltage Reading at panel connection, Pump OFF: L1, L2 _____ L2, L3 _____ L1, L3 _____

Voltage Reading at panel connection, Pump ON: L1, L2 _____ L2, L3 _____ L1, L3 _____

Amperage Draw, Pump ON: L1 _____ L2 _____ L3 _____

Submersible Pumps

Are BAF and guide rails level / plumb? YES___ NO___

Is pump seated on discharge properly? YES___ NO___

Are level controls installed away from turbulence? YES___ NO___

Is level control operating properly? YES___ NO___

Is pump fully submerged during operation? YES___ NO___

Follow up/Corrective Action Required

YES___ NO___

Additional Comments:

Startup performed by: _____ Date: _____

Present at Start-Up

() Engineer: _____ () Operator: _____

() Contactor: _____ () Other: _____

All parties should retain a copy of this report for future trouble shooting/reference



PUMPS & SYSTEMS

A Crane Co. Company

420 Third Street
Piqua, Ohio 45356
Phone: (937) 778-8947
Fax: (937) 773-7157
www.cranepumps.com

83 West Drive, Brampton
Ontario, Canada L6T 2J6
Phone: (905) 457-6223
Fax: (905) 457-2650

