

BARNES®

INSTALLATION and OPERATION MANUAL Submersible Non-Clog Pumps

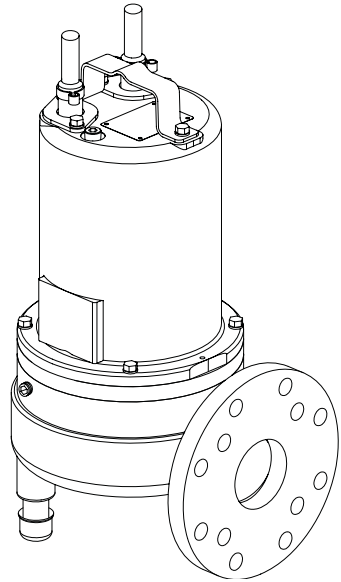

Series: 4SE-L & DS
.9, 1.4 & 1.9 HP, 1750RPM, 60 Hz.

Single and Double Seal

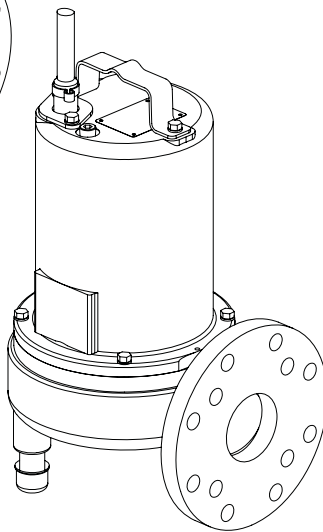

IMPORTANT!

Read all instructions in this manual before operating pump.

As a result of Crane Pumps & Systems, Inc., constant product improvement program, product changes may occur. As such Crane Pumps & Systems reserves the right to change product without prior written notification.

CRANE®

A Crane Co. Company

PUMPS & SYSTEMS

420 Third Street
Piqua, Ohio 45356
Phone: (937) 778-8947
Fax: (937) 773-7157
www.cranepumps.com

83 West Drive, Bramton
Ontario, Canada L6T 2J6
Phone: (905) 457-6223
Fax: (905) 457-2650



Form No. 105242-Rev. P

TABLE OF CONTENTS

SAFETY FIRST	3
A. PUMP SPECIFICATIONS	4 - 5
B. GENERAL INFORMATION	6
C. INSTALLATION	6 - 7
ELECTRICAL DATA	8
D. START-UP OPERATION	7 - 8
E. PREVENTATIVE MAINTENANCE	8
F. SERVICE and REPAIR	8 - 13
G. REPLACEMENT PARTS.....	13
TROUBLE SHOOTING	15
SINGLE SEAL - CROSS-SECTION (Fig. 15)	16
SINGLE SEAL - EXPLODED VIEW (Fig. 16)	17
DOUBLE SEAL - CROSS-SECTION (Fig. 17).....	18
DOUBLE SEAL - EXPLODED VIEW (Fig. 18).....	19
PARTS LIST	20 - 22
RETURNED GOODS POLICY.....	23
WARRANTY	24
START-UP REPORT	25 - 26
WARRANTY REGISTRATION	
SPECIAL TOOLS AND EQUIPMENT	
INSULATION TESTER (MEGGER)	
DIELECTRIC TESTER	
SEAL TOOL KIT (see parts list)	
PRESSURE GAUGE KIT (see parts list)	

SAFETY FIRST!

Please Read This Before Installing Or Operating Pump.
This information is provided for **SAFETY and to PREVENT EQUIPMENT PROBLEMS**. To help recognize this information, observe the following symbols:



IMPORTANT! Warns about hazards that can result in personal injury or Indicates factors concerned with assembly, installation, operation, or maintenance which could result in damage to the machine or equipment if ignored.

CAUTION ! Warns about hazards that can or will cause minor personal injury or property damage if ignored. Used with symbols below.

WARNING ! Warns about hazards that can or will cause serious personal injury, death, or major property damage if ignored. Used with symbols below.



Hazardous fluids can cause fire or explosions, burnes or death could result.



Extremely hot - Severe burnes can occur on contact.



Biohazard can cause serious personal injury.



Hazardous fluids can Hazardous pressure, eruptions or explosions could cause personal injury or property damage.



Rotating machinery Amputation or severe laceration can result.



Hazardous voltage can shock, burn or cause death.

Only qualified personnel should install, operate and repair pump. Any wiring of pumps should be performed by a qualified electrician.



WARNING ! - To reduce risk of electrical shock, pumps and control panels must be properly grounded in accordance with the National Electric Code (NEC) or the Canadian Electrical Code (CEC) and all applicable state, province, local codes and ordinances.



WARNING! - To reduce risk of electrical shock, always disconnect the pump from the power source before handling or servicing. Lock out power and tag.



WARNING! Operation against a closed discharge valve will cause premature bearing and seal failure on any pump, and on end suction and self priming pump the heat build may cause the generation of steam with resulting dangerous pressures. It is recommended that a high case temperature switch or pressure relief valve be installed on the pump body.



CAUTION ! Never operate a pump with a plug-in type power cord without a ground fault circuit interrupter.



CAUTION! Pumps build up heat and pressure during operation-allow time for pumps to cool before handling or servicing.



WARNING! - DO NOT pump hazardous materials (flammable, caustic, etc.) unless the pump is specifically designed and designated to handle them.



Do not block or restrict discharge hose, as discharge hose may whip under pressure.



WARNING! - DO NOT wear loose clothing that may become entangled in the impeller or other moving parts.



WARNING! - Keep clear of suction and discharge openings. **DO NOT** insert fingers in pump with power connected.



Always wear eye protection when working on pumps.



Make sure lifting handles are securely fastened each time before lifting. **DO NOT** operate pump without safety devices in place. Always replace safety devices that have been removed during service or repair. Secure the pump in its operating position so it can not tip over, fall or slide.



DO NOT exceed manufacturers recommendation for maximum performance, as this could cause the motor to overheat.



DO NOT remove cord and strain relief. Do not connect conduit to pump.



WARNING! Cable should be protected at all times to avoid punctures, cut, bruises and abrasions - inspect frequently. Never handle connected power cords with wet hands.



WARNING! To reduce risk of electrical shock, all wiring and junction connections should be made per the NEC or CEC and applicable state or province and local codes. Requirements may vary depending on usage and location.



WARNING! Submersible Pumps are not approved for use in swimming pools, recreational water installations, decorative fountains or any installation where human contact with the pumped fluid is common.



WARNING! Products Returned Must Be Cleaned, Sanitized, Or Decontaminated As Necessary Prior To Shipment, To Insure That Employees Will Not Be Exposed To Health Hazards In Handling Said Material. All Applicable Laws And Regulations Shall Apply.



Bronze/brass and bronze/brass fitted pumps may contain lead levels higher than considered safe for potable water systems. Lead is know to cause cancer and birth defects or other reproductive harm. Various government agencies have determined that leaded copper alloys should not be used in potable water applications. For non-leaded copper alloy materials of construction, please contact factory.



IMPORTANT! - Crane Pumps & Systems, Inc. is not responsible for losses, injury, or death resulting from a failure to observe these safety precautions, misuse or abuse of pumps or equipment.

SECTION: A - PUMP SPECIFICATIONS - SINGLE SEAL

DISCHARGE 3" (76) & 4" 125 lb. Horizontal Flange
LIQUID TEMPERATURE 104°F (40°C) Intermittent
MOTOR HOUSING Cast Iron ASTM A-48, Class 30
VOLUTE Cast Iron ASTM A-48, Class 30
SEAL PLATE Cast Iron ASTM A-48, Class 30
IMPELLER *Design* 2 Vane, Open with Pump out vanes on Back side. Dynamically balanced, ISO G6.3
Material Cast Iron ASTM A-48, Class 30
SHAFT 416 Stainless Steel
SQUARE RINGS Buna-N
HARDWARE 300 Series Stainless Steel
PAINT Air dry enamel, top coat
SEAL *Design* Single Mechanical
Material Rotating Faces - Carbon
 Stationary Faces - Ceramic
 Elastomer - Buna-N
 Hardware - 300 series stainless steel
CORD ENTRY 30 ft. (9.1m) Cord. Plug on 120 volt Quick connect. Custom molded for sealing and strain relief
SPEED 1750 RPM, 60Hz (nominal)

UPPER BEARING:
Design Single Row, Ball, Oil Lubricated
Load Radial
LOWER BEARING:
Design Single Row, Ball, Oil Lubricated
Load Radial & Thrust
MOTOR: *Design* NEMA L, Single phase, NEMA B, Three Phase Torque Curve, Oil Filled, Squirrel Cage Induction
Insulation Class B
SINGLE PHASE Permanent Split Capacitor (PSC) Includes overload protection in motor
THREE PHASE 200-240/480 is Tri voltage motor. 600V. Requires overload protection to be included in control panel
OPTIONAL EQUIPMENT:
 Seal Material, Impeller Trims, Additional Cord, N/C Temperature Sensors with cord for 3 Phase pumps (Requires relay in Control Panel).

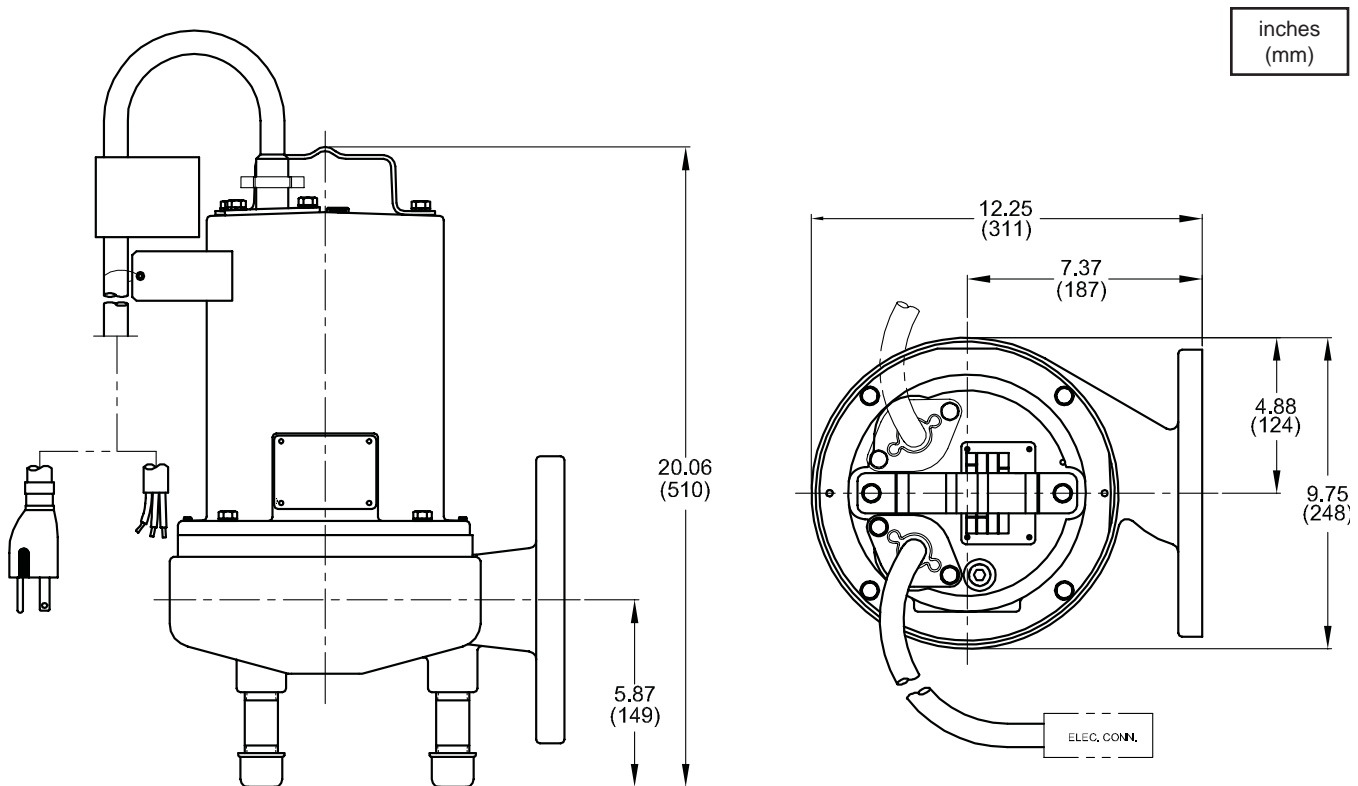

IMPORTANT !

- 1.) PUMP MAY BE OPERATED "DRY" FOR EXTENDED PERIODS WITHOUT DAMAGE TO MOTOR AND/OR SEALS.
- 2.) THIS PUMP IS APPROPRIATE FOR THOSE APPLICATIONS SPECIFIED AS CLASS I DIVISION II HAZARDOUS LOCATIONS.
- 3.) THIS PUMP IS NOT APPROPRIATE FOR THOSE APPLICATIONS SPECIFIED AS CLASS I DIVISION I HAZARDOUS LOCATIONS.
- 4.) INSTALLATIONS SUCH AS DECORATIVE FOUNTAINS OR WATER FEATURES PROVIDED FOR VISUAL ENJOYMENT MUST BE INSTALLED IN ACCORDANCE WITH THE NATIONAL ELECTRIC CODE ANSI/NFPA 70 AND/OR THE AUTHORITY HAVING JURISDICTION. THIS PUMP IS NOT INTENDED FOR USE IN SWIMMING POOLS, RECREATIONAL WATER PARKS, OR INSTALLATIONS IN WHICH HUMAN CONTACT WITH PUMPED MEDIA IS A COMMON OCCURRENCE.

SECTION: A - PUMP SPECIFICATIONS - DOUBLE SEAL

DISCHARGE 3" (76) & 4" 125 lb. Horizontal Flange
LIQUID TEMPERATURE 104°F (40°C) Intermittent
MOTOR HOUSING Cast Iron ASTM A-48, Class 30
VOLUTE Cast Iron ASTM A-48, Class 30
SEAL PLATE Cast Iron ASTM A-48, Class 30
IMPELLER *Design* 2 Vane, Open with Pump out vanes on Back side. Dynamically balanced, ISO G6.3
Material Cast Iron ASTM A-48, Class 30
SHAFT 416 Stainless Steel
SQUARE RINGS Buna-N
HARDWARE 300 Series Stainless Steel
PAINT Air dry enamel, top coat
SEAL *Design* Tandem Mechanical with Oil-Filled reservoir
Material Rotating Faces - Carbon
 Stationary Faces - Ceramic
 Elastomer - Buna-N
 Hardware - 300 series stainless steel
CORD ENTRY 30 ft. (9.1m) Cord. Plug on 120 volt Quick connect. Custom molded for sealing and strain relief
SPEED 1750 RPM, 60Hz (nominal)

UPPER BEARING:

Design Single Row, Ball, Oil Lubricated
Load Radial

LOWER BEARING:

Design Single Row, Ball, Oil Lubricated
Load Radial & Thrust

MOTOR:

Design NEMA L, Single phase, NEMA B, Three Phase Torque Curve, Oil Filled, Squirrel Cage Induction
Insulation Class B

SINGLE PHASE.....

Permanent Split Capacitor (PSC) Includes overload protection in motor

THREE PHASE.....

200-240/480 is Tri voltage motor. 600V. Requires overload protection to be included in control panel

OPTIONAL EQUIPMENT:

Seal Material, Impeller Trims, Additional Cord, N/C Temperature Sensors with cord for 3 Phase pumps (Requires relay in Control Panel). N/O Moisture Sensor with cord for DS pumps (Requires relay in Control Panel).

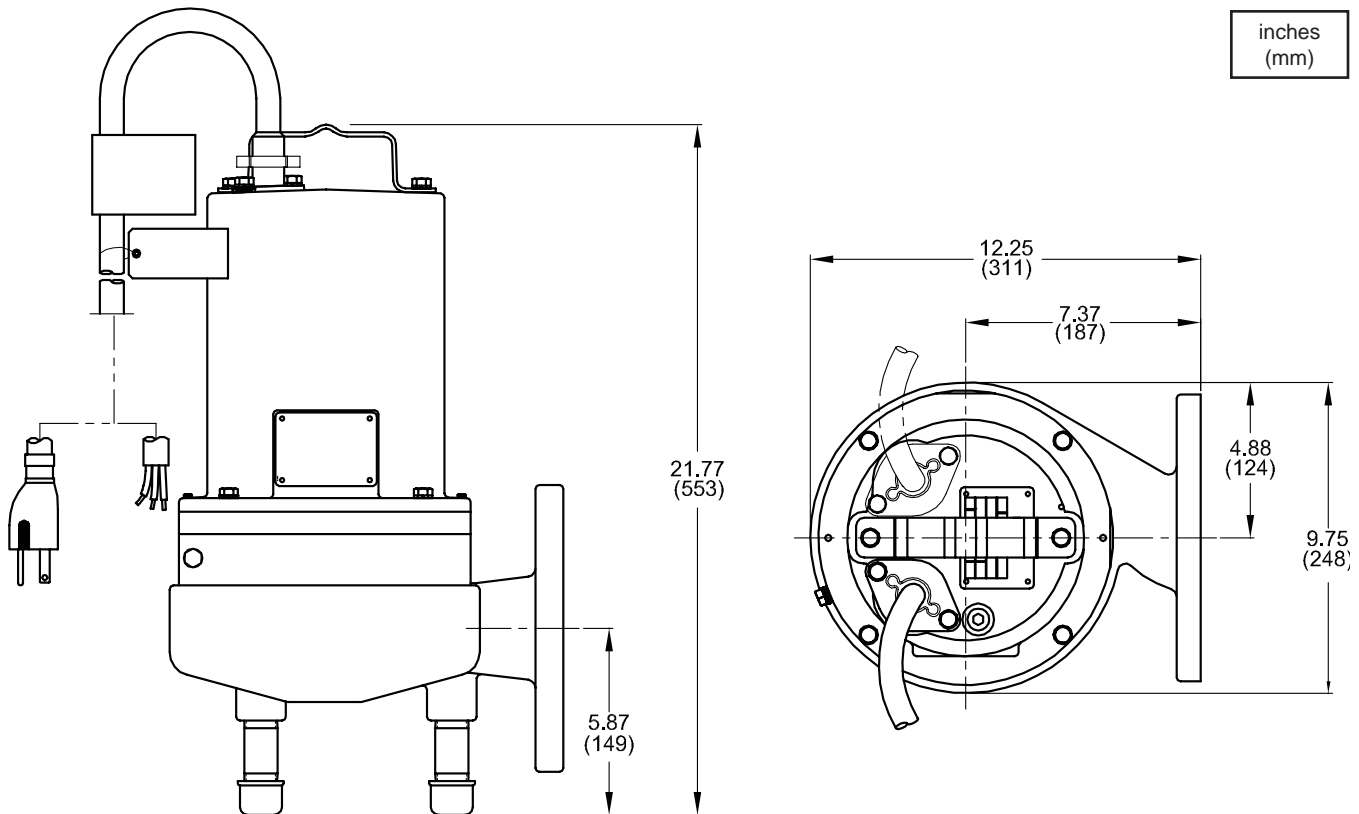

IMPORTANT !

- 1.) PUMP MAY BE OPERATED "DRY" FOR EXTENDED PERIODS WITHOUT DAMAGE TO MOTOR AND/OR SEALS.
- 2.) THIS PUMP IS APPROPRIATE FOR THOSE APPLICATIONS SPECIFIED AS CLASS I DIVISION II HAZARDOUS LOCATIONS.
- 3.) THIS PUMP IS NOT APPROPRIATE FOR THOSE APPLICATIONS SPECIFIED AS CLASS I DIVISION I HAZARDOUS LOCATIONS.
- 4.) INSTALLATIONS SUCH AS DECORATIVE FOUNTAINS OR WATER FEATURES PROVIDED FOR VISUAL ENJOYMENT MUST BE INSTALLED IN ACCORDANCE WITH THE NATIONAL ELECTRIC CODE ANSI/NFPA 70 AND/OR THE AUTHORITY HAVING JURISDICTION. THIS PUMP IS NOT INTENDED FOR USE IN SWIMMING POOLS, RECREATIONAL WATER PARKS, OR INSTALLATIONS IN WHICH HUMAN CONTACT WITH PUMPED MEDIA IS A COMMON OCCURRENCE.

SECTION B: GENERAL INFORMATION

B-1) To the Purchaser:

Congratulations! You are the owner of one of the finest pumps on the market today. CP&S pumps are products engineered and manufactured of high quality components. Over one hundred years of pump building experience along with a continuing quality assurance program combine to produce a pump which will stand up to the toughest applications. This manual will provide helpful information concerning installation, maintenance, and proper service guidelines.

B-2) Receiving:

Upon receiving the pump, it should be inspected for damage or shortages. If damage has occurred, file a claim immediately with the company that delivered the pump. If the manual is removed from the packaging, do not lose or misplace.

B-3) Storage:

Short Term- CP&S Pumps are manufactured for efficient performance following short inoperative periods in storage. For best results, pumps can be retained in storage, as factory assembled, in a dry atmosphere with constant temperatures for up to six (6) months. Long Term- Any length of time exceeding six (6) months, but not more than twenty-four (24) months. The unit should be stored in a temperature controlled area, a roofed over walled enclosure that provides protection from the elements (rain, snow, wind-blown dust, etc.), and whose temperature can be maintained between +40 deg. F and +120 deg. F. (4.4 - 49°C). Pump should be stored in its original shipping container. On initial start up, rotate impeller by hand to assure seal and impeller rotate freely. If it is required that the pump be installed and tested before the long term storage begins, such installation will be allowed provided:

- 1.) The pump is not installed under water for more than one (1) month.
- 2.) Immediately upon satisfactory completion of the test, the pump is removed, thoroughly dried, repacked in the original shipping container, and placed in a temperature controlled storage area.

B-4) Service Centers:

For the location of the nearest Barnes Service Center, check your Barnes representative or Crane Pumps & Systems, Inc., Service Department in Piqua, Ohio, telephone (937) 778-8947 or Crane Pumps & Systems Canada, in Brampton, Ontario, (905) 457-6223.

SECTION C: INSTALLATION

C-1) Location:

These pumping units are self-contained and are recommended for use in a sump, lift station or basin. The sump, lift station or basin shall be vented in accordance with local plumbing codes. This pump is designed to pump sewage, effluent, or other nonexplosive or noncorrosive wastewater. and shall **NOT** be installed in locations classified as hazardous in accordance with the National Electrical Code (NEC), ANSI/NFPA 70 or the Canadian Electrical Code (CEC). Never install the pump in a trench, ditch or hole with a dirt bottom; the legs will sink into the dirt and the suction will become plugged.

C-1.1) Submergence:

It is recommended that the pump be operated in the submerged condition and the sump liquid level should never be less than dimension "A" in Figure 1.

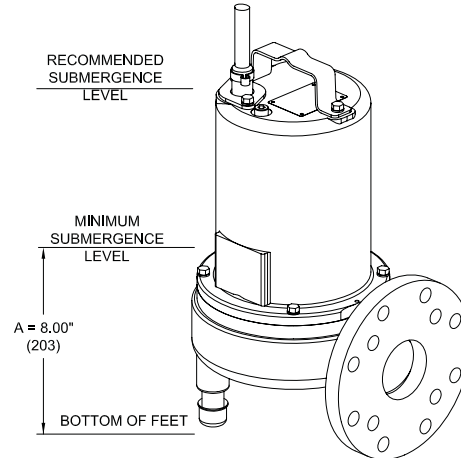

FIGURE 1

C-2) Discharge:

Discharge piping should be as short as possible. Both a check valve and a shut-off valve are recommended for each pump being used. The check valve is used to prevent backflow into the sump. Excessive backflow can cause flooding and/or damage to the pump. The shut-off valve is used to stop system flow during pump or check valve servicing.

Barnes Pumps supplies a breakaway fitting discharge system designed to allow the submersible wastewater pump to be installed or removed without requiring personnel to enter the wet well.

Place the Break Away Fitting (BAF) in position. Temporarily secure the guide rails in the upper mounting brackets and locate the base on the bottom of the wet well. Level the base with grout and/or shims. Install the intermediate support brackets, if required. Make sure the rails are in a true vertical position so the pump will clear the access opening and will slide freely down the rails into place on the discharge stationary fitting. Once the rails are in proper alignment, bolt the base into the floor of the station and connect the discharge pipe to the elbow.

Connect the movable portion and other supplied fittings of the BAF onto the pump and lower into wet well. See the Break Away Fitting manual for more information.

C-3) Liquid Level Controls:

The level controls are to be supported by a mounting bracket that is attached to the sump wall, cover or junction box. Cord grips are used to hold the cords in place on the mounting bracket. The control level can be changed by loosening the grip and adjusting the cord length as per the plans and specifications. Be certain that the level controls cannot hang up or foul in it's swing and that the pump is completely submerged when the level control is in the "Off" mode.

Figure 2 shows a typical connection for 1 phase 120 volt pumps with a piggy-back plug, for manual and automatic operations.

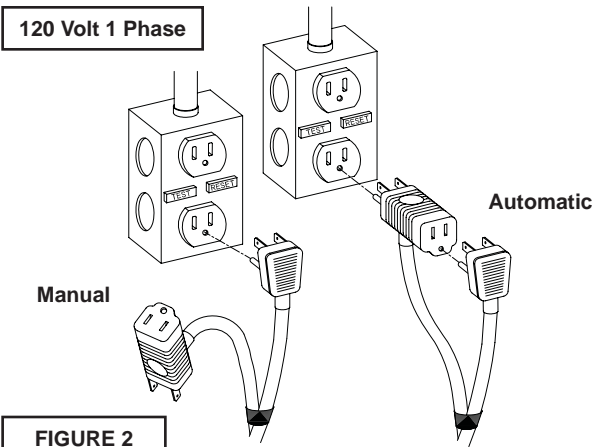

FIGURE 2

- Automatic - Plug float cord into outlet, then plug pump cord into float cord.
- Manual - Plug pump cord directly into outlet

C-4) Electrical Connections:

An acceptable motor control switch shall be provided at the time of installation.

C-4.1) Power and Control Cable:

The cord assembly mounted to the pump must not be modified in any way except for shortening to a specific application. Any splice between the pump and the control panel must be made in accordance with all applicable electric codes. It is recommended that a junction box, if used, be mounted outside the sump or be of at least Nema 4 (EEMAC-4) construction if located within the wet well. **Do not use the power or control cable to lift pump. NOTE: The white wire is NOT a neutral or ground lead, but a power carrying conductor.**

C-4.2) Overload Protection:

C-4.2-1) Three Phase (Optional) - The normally closed (N/C) thermal sensor is embedded in the motor windings and will detect excessive heat in the event an overload condition occurs. The thermal sensor will trip when the windings become too hot and will automatically reset itself when the pump motor cools to a safe temperature. It is recommended that the thermal sensor be connected in series to an alarm device to alert the operator of an overload condition, and/or the motor starter coil to stop the pump. In the event of an overload, the source of this condition should be determined and rectified immediately. **DO NOT LET THE PUMP CYCLE OR RUN IF AN OVERLOAD CONDITION OCCURS !**

C-4.2-2) Single Phase (Standard) - The type of in-winding overload protector used is referred to as an inherent overheating protector and operates on the combined effect of temperature and current. This means that the overload protector will trip out and shut the pump off if the windings become too hot, or the load current passing through them becomes too high. It will then automatically reset and start the pump up after the motor cools to a safe temperature. In the event of an overload, the source of this condition should be determined and rectified immediately. **DO NOT LET THE PUMP CYCLE OR RUN IF AN OVERLOAD CONDITION OCCURS !**

If current through the temperature sensor exceeds the values listed, an intermediate control circuit relay must be used to reduce the current or the sensor will not work properly.

TEMPERATURE SENSOR ELECTRICAL RATINGS		
Volts	Continuous Amperes	Inrush Amperes
110-120	3.00	30.0
220-240	1.50	15.0
440-480	0.75	7.5
600	0.60	6.0

C-4.3) Moisture Sensors - DS Models: (Optional)

A normally open (N/O) detector is installed in the pump seal chamber which will detect any moisture present. It is recommended that this detector be connected in series to an alarm device or the motor started coil to alert the operator that a moisture detect has occurred. In the event of a moisture detect, check the individual moisture sensor probe leads for continuity, (∞ resistance = no moisture) and the junction box/control box for moisture content. The above situations may induce a false signal in the moisture detecting circuit. If none of the above tests prove conclusive, the pump(s) should be pulled and the source of the failure identified and repaired.

IF A MOISTURE DETECT HAS OCCURRED SCHEDULE MAINTENANCE AS SOON AS POSSIBLE.

C-4.4) Wire Size:

Consult a qualified electrician for proper wire size if additional power cable length is required. See table for electrical information.

SECTION: D START-UP OPERATION

D-1) Check Voltage and Phase:

Before operating pump, compare the voltage and phase information stamped on the pump identification plate to the available power.

D-2) Check Pump Rotation:

Before putting pump into service for the first time, the motor rotation must be checked. Improper motor rotation can result in poor pump performance and can damage the motor and/or pump. To check the rotation, suspend the pump freely, momentarily apply power and observe the "kickback". "Kickback" should always be in a counter-clockwise direction as viewed from the top of the pump motor housing.

D-2.1) Incorrect Rotation for Three-Phase Pumps:

In the event that the rotation is incorrect for a three-phase installation, interchange any two power cable leads at the control box. **DO NOT** change leads in the cable housing in the motor. Recheck the "kickback" rotation again by momentarily applying power.

D-2.2) Incorrect Rotation for Single-Phase Pumps:

In the unlikely event that the rotation is incorrect for a single phase pump, contact a Barnes Service Center.

D-3) Start-Up Report:

Included at the end of this manual is a start-up report sheet, this sheet is to be completed as applicable. Return one copy to Barnes and store the second in the control panel or with the pump manual if no control panel is used. It is important to record this data at initial start-up since it will be useful to refer to should servicing the pump be required in the future.

MODEL NO	HP	VOLT/PH	Hz	RPM (Nom)	NEMA START CODE	FULL LOAD AMPS	LOCKED ROTOR AMPS	CORD SIZE	CORD TYPE	CORD O.D inch (mm)	WINDING RESISTANCE		
											Emerson Main-Start	Franklin Main-Start	G.E. Main-Start
4SE914L	0.9	120/1	60	1750	A	11.6	21.3	14/3	SJTOW	0.373 (9.5)			1.51-16.10
4SE924L	0.9	240/1	60	1750	C	5.9	14.9	14/3	SOW	0.530 (13.5)	3.38-9.30		5.69-18.74
4SE994L	0.9	200-240/3	60	1750	C/F	3.2/3.0	9.8/11.0	14/4	SOW	0.570 (14.5)	10.20	13.00	
4SE944L	0.9	480/3	60	1750	E	1.5	5.3	14/4	SOW	0.570 (14.5)	40.80	52.00	
4SE954L	0.9	600/3	60	1750	C	1.0	3.4	14/4	SOW	0.570 (14.5)		77.60	89.76
4SE1474L	1.4	200-240/1	60	1750	A/D	7.4/7.0	21.5/25.8	14/3	SOW	0.530 (13.5)	1.86-10.20		2.74-10.56
4SE1494L	1.4	200-240/3	60	1750	B/E	4.8/4.5	13.7/15.4	14/4	SOW	0.570 (14.5)		5.49	6.28
4SE1444L	1.4	480/3	60	1750	E	2.2	7.7	14/4	SOW	0.570 (14.5)		21.96	24.51
4SE1454L	1.4	600/3	60	1750	F	1.5	7.2	14/4	SOW	0.570 (14.5)		34.36	36.60
4SE1974L	1.9	200-240/1	60	1750	A/B	8.8/8.3	21.5/25.8	14/3	SOW	0.530 (13.5)	1.86-10.20		2.74-10.56
4SE1994L	1.9	200-240/3	60	1750	A/B	5.3/5.1	13.7/15.4	14/4	SOW	0.570 (14.5)		5.49	6.28
4SE1944L	1.9	480/3	60	1750	B	2.5	7.7	14/4	SOW	0.570 (14.5)		21.96	24.51
4SE1954L	1.9	600/3	60	1750	C	1.9	7.2	14/4	SOW	0.570 (14.5)		34.36	36.60
4SE914DS	0.9	120/1	60	1750	A	11.6	21.3	14/3	SJTOW	0.373 (9.5)			1.51-16.10
4SE924DS	0.9	240/1	60	1750	C	5.9	14.9	14/3	SOW	0.530 (13.5)	3.38-9.30		5.69-18.74
4SE994DS	0.9	200-240/3	60	1750	C/F	3.2/3.0	9.8/11.0	14/4	SOW	0.570 (14.5)	10.20	13.00	
4SE944DS	0.9	480/3	60	1750	E	1.5	5.3	14/4	SOW	0.570 (14.5)	40.80	52.00	
4SE954DS	0.9	600/3	60	1750	C	1.0	3.4	14/4	SOW	0.570 (14.5)		77.60	89.76
4SE1474DS	1.4	200-240/1	60	1750	A/D	7.4/7.0	21.5/25.8	14/3	SOW	0.530 (13.5)	1.86-10.20		2.74-10.56
4SE1494DS	1.4	200-240/3	60	1750	B/E	4.8/4.5	13.7/15.4	14/4	SOW	0.570 (14.5)		5.49	6.28
4SE1444DS	1.4	480/3	60	1750	E	2.2	7.7	14/4	SOW	0.570 (14.5)		21.96	24.51
4SE1454DS	1.4	600/3	60	1750	F	1.5	7.2	14/4	SOW	0.570 (14.5)		34.36	36.60
4SE1974DS	1.9	200-240/1	60	1750	A/B	8.8/8.3	21.5/25.8	14/3	SOW	0.530 (13.5)	1.86-10.20		2.74-10.56
4SE1994DS	1.9	200-240/3	60	1750	A/B	5.3/5.1	13.7/15.4	14/4	SOW	0.570 (14.5)		5.49	6.28
4SE1944DS	1.9	480/3	60	1750	B	2.5	7.7	14/4	SOW	0.570 (14.5)		21.96	24.51
4SE1954DS	1.9	600/3	60	1750	C	1.9	7.2	14/4	SOW	0.570 (14.5)		34.36	35.60

Winding Resistance ± 5%, measured from terminal block. Pump Rated for Operation at ± 10% Voltage at Motor.

OPTIONAL - Temperature sensor cord for 3 phase models is 14/3 SOW, 0.530 (13.5mm) O.D.

OPTIONAL - Moisture sensor cord is 18/5 SOW, 0.470 (12mm) O.D.

OPTIONAL - Moisture & Temperature sensor cord for 3 phase models is 18/5 SOW, 0.470 (12mm) O.D.

D-3.1) Identification Plate:

Record the numbers from the pump identification plate on both START-UP REPORTS provided at the end of the manual for future reference.

normal sewage pumping without failing. However as with any mechanical piece of equipment a preventive maintenance program is recommended and suggested to include the following checks:

D-3.2) Insulation Test:

Before the pump is put into service, an insulation (megger) test should be performed on the motor. The resistance values (ohms) as well as the voltage (volts) and current (amps) should be recorded on the start-up report.

- 1) Inspect motor chamber for oil level and contamination and repair as required per section F-1.
- 2) Inspect impeller and body for excessive build-up or clogging and repair as required per section F-2.
- 3) Inspect motor and bearings and replace as required per section F-3.
- 4) Inspect seal for wear or leakage and repair as required per section F-4.

D-3.3) Pump-Down Test:

After the pump has been properly wired and lowered into the basin, sump or lift station, it is advisable to check the system by filling with liquid and allowing the pump to operate through its pumping cycle. The time needed to empty the system, or pump-down time along with the volume of water, should be recorded on the start-up report.

SECTION F: SERVICE AND REPAIR

NOTE: All item numbers in () refer to Figures 15 thru 18

SECTION E: PREVENTATIVE MAINTENANCE

As the motor is oil filled, no lubrication or other maintenance is required, and generally Barnes Pumps will give very reliable service and can be expected to operate for years on

F-1) Lubrication:

Anytime the pump is removed from operation, the cooling oil in the motor housing (6) should be checked visually for oil level and contamination.

F-1.1) Checking Oil:

Motor Housing- To check oil, set unit upright. Remove pipe plug (39) from housing (6). With a flashlight, visually inspect the oil in the motor housing (6) to make sure it is clean and clear, light amber in color and free from suspended particles. Milky white oil indicates the presence of water. Oil level should be just above the motor when pump is in vertical position.

F-1.2) Testing Oil:

- 1.) Place pump on it's side, remove pipe plug (39), from motor housing (6) and drain oil into a clean, dry container.
- 2.) Check oil for contamination using an oil tester with a range to 30 Kilovolts breakdown.
- 3.) If oil is found to be clean and uncontaminated (measuring above 15 KV. breakdown), refill the motor housing as per section F-1.4.
- 4.) If oil is found to be dirty or contaminated (or measures below 15 KV. breakdown), the the pump must be carefully inspected for leaks at the shaft seal (28), cable assemblies (16) and (56 if used), square ring (27) and pipe plug (39), before refilling with oil. To locate the leak, perform a pressure test as per section F-1.3. After leak is repaired, dispose of old oil properly, and refill with new oil as per section F-1.4.

F-1.3) Pressure Test:

Pumps that have been disassembled, Motor Housing- If the pump has been disassembled, the oil should be drained before a pressure test, as described in section F-1.1. Remove pipe plug (39) from motor housing (6). Apply pipe sealant to pressure gauge assembly and tighten into hole (See Figure 3). Pressurize motor housing to 10 P.S.I. Use soap solution around the sealed areas and inspect joints for "air bubbles".

If, after five minutes, the pressure is still holding constant, and no "bubbles" are observed, slowly bleed the pressure and remove the gauge assembly. Replace oil as described in section F-1.4. If the pressure does not hold, then the leak must be located and repaired.

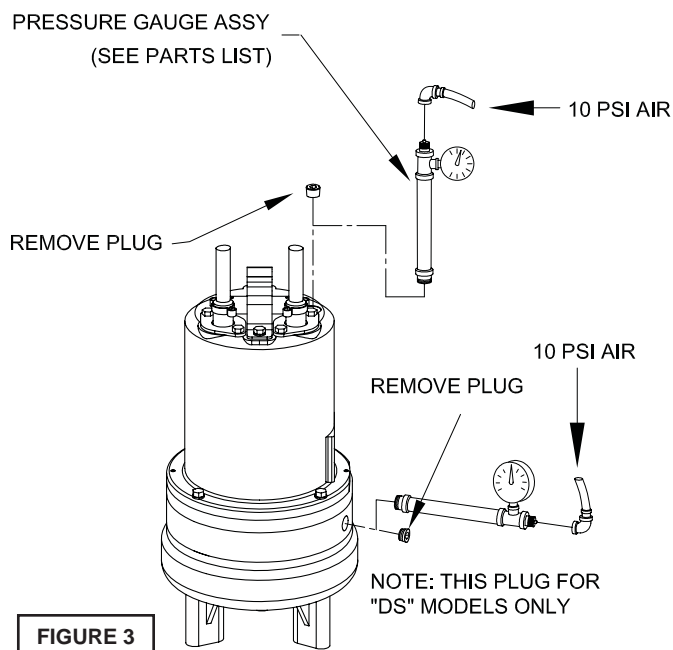

FIGURE 3

Pumps that have NOT been disassembled, Motor Housing-

The pressure test may be done with the oil at its normal level. Remove pipe plug (39) from motor housing (6). Apply pipe sealant to pressure gauge assembly and tighten into hole (see Figure 3). Pressurize motor housing to 10 P.S.I. Use soap solution around the sealed areas above the oil level and inspect joints for "air bubbles". For sealed areas below the oil level, leaks will seep oil.

If, after five minutes, the pressure is still holding constant, and no "bubbles"/oil seepage is observed, slowly bleed the pressure and remove the gauge assembly. If the pressure does not hold, then the leak must be located and repaired.

Seal Chamber (DS Units Only)- Set unit on its side with fill plug (44) downward, remove plug (44) and drain all oil from seal chamber. Apply pipe sealant to pressure gauge assembly and tighten into hole in outer seal plate (29). Pressurize seal chamber to 10 P.S.I. and check for leaks as outlined above.



CAUTION ! - Pressure builds up extremely fast, increase pressure by "TAPPING" air nozzle. Too much pressure will damage seal. DO NOT exceed 10 P.S.I.

F-1.4) Replacing Oil:

Motor Housing- Set unit upright and refill with new cooling oil as per Table 1 (see parts list for amount). Fill to just above motor as an air space must remain in the top of the motor housing to compensate for oil expansion (see Figures 15 & 17). Apply pipe thread compound to threads of pipe plug (39) then assemble to motor housing (6).



IMPORTANT! - For single phase units, oil level should be below capacitor.

Seal Chamber (DS Units Only)- Set unit on its side, with plug (44) upward, and refill with new oil as per Table 1 (see parts list for amount). Apply pipe thread compound to threads of pipe plug (44) and assemble to outer seal plate (29).



WARNING ! - DO NOT overfill oil. Overfilling of motor housing with oil can create excessive and dangerous hydraulic pressure which can destroy the pump and create a hazard. Overfilling oil voids warranty.

TABLE 1 - COOLING OIL - Dielectric	
SUPPLIER	GRADE
BP	Enerpar SE100
Conoco	Pale Paraffin 22
Mobile	D.T.E. Oil Light
G & G Oil	Circulating 22
Imperial Oil	Voltesso-35
Shell Canada	Transformer-10
Texaco	Diala-Oil-AX
Woco	Premium 100

F-2) Impeller and Volute Service:

F-2.1) Disassembly and Inspection:

To clean out volute (1) or replace impeller (33), disconnect power, remove hex bolts (26), and lockwasher (12), vertically lift motor and seal plate assembly from volute (1) see Figure 4.

Clean out body if necessary. Clean and examine impeller (33), for pitting or wear and replace if required, inspect gasket (36) and replace if cut or damaged. If the impeller (33) needs replacing, place a flat screwdriver in the slot of the end of the shaft to hold the shaft stationary while unscrewing the jam nut (66) and impeller (33).

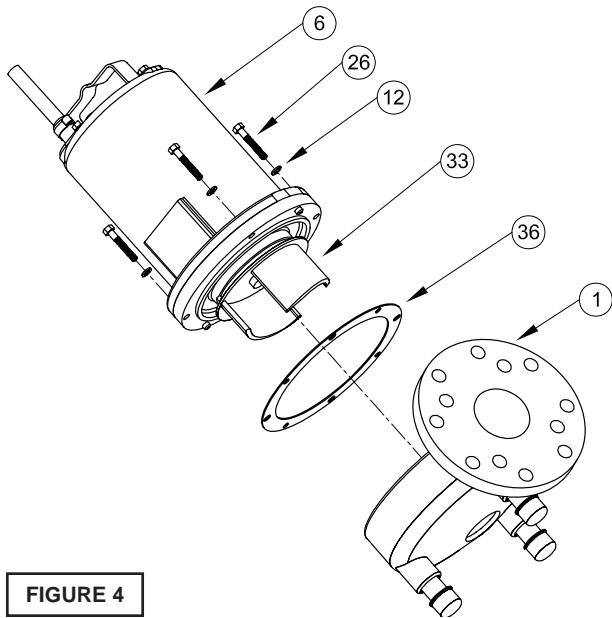

FIGURE 4

F-2.2) Reassembly:

To install impeller (33), clean the threads with thread locking compound cleaner. Apply removable Loctite® 603 or equivalent to shaft threads. Screw impeller onto the shaft hand tight while using a screwdriver in the slot at the end of the shaft to hold it stationary. Apply thread locking compound (57) to shaft threads. Then install jam nut (66) and torque to 40 ft. lbs. It is important that the spring of the lower shaft seal (28) seats in the hub of the impeller (33). Rotate impeller to check for binding. Position gasket (36) on volute flange and position impeller and motor housing on volute (1). Position lockwasher (12) on cap screw (26) and screw into volute (1). Torque to 100 in-lbs. Check for free rotation of motor and impeller.

F-3) Shaft Seal Service:

CAUTION ! - Handle seal parts with extreme care. DO NOT scratch or mar lapped surfaces.

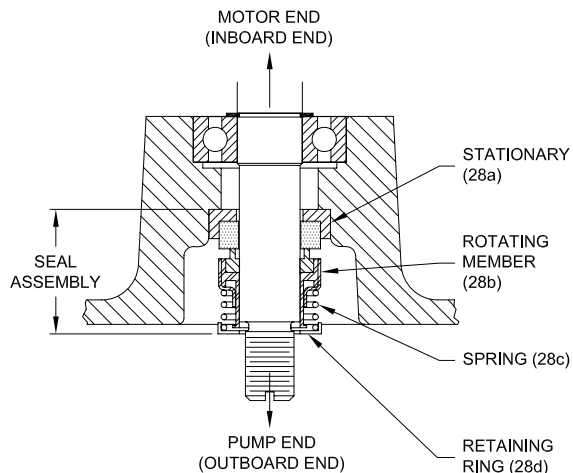

FIGURE 5 - SINGLE SEAL

F-3.1) Disassembly and Inspection:

Outer Seal (All Units) - To expose shaft seal (28) for examination, disassemble volute and impeller as outlined in paragraph F-2.1. If further repair is required, remove retaining ring (28d), spring (28c) and rotating member (28b) from shaft (see Figures 5 & 6). Examine all seal parts and especially contact faces. Inspect seal for signs of wear such as uneven wear pattern on stationary members, chips and scratches on either seal face. **DO NOT** interchange seal components, replace the entire shaft seal (28). If replacing seal, remove stationary (28a) by prying out with flat screwdriver.

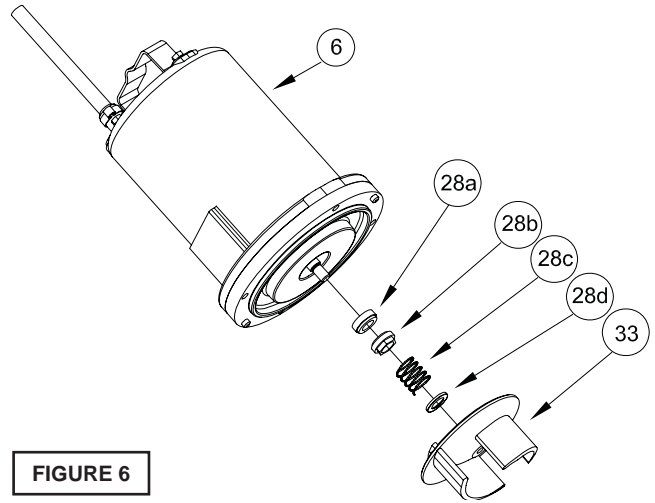

FIGURE 6

Inner Seal (DS Units Only)-

To expose inner shaft seal (28) for examination, remove outer seal as outlined above. Remove socket head cap screws (64). Lift outer seal plate (29) and square-ring (27) from inner seal plate (5) see Figure 7. If further repair is required, remove snap ring (32), retaining ring (28d), spring (28c) and rotating member (28b) from shaft. Examine as outlined in outer seal paragraph. If replacing seal, remove stationary (28a) by prying out with flat screwdriver.

F-3.2) Reassembly:

Inner Seal (DS Units Only)- Clean and oil seal cavities in seal plates (5, 29). Lightly oil (**DO NOT use grease**) outer surface of stationary member (28a). Press stationary member (28a) firmly into inner seal plate (5), using a seal pusher. Nothing but the seal pusher is to come in contact with seal face (see Figure 8).

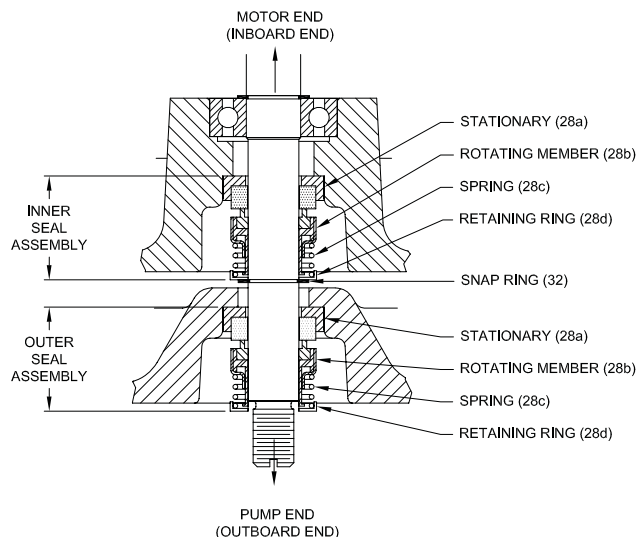

FIGURE 5 - DOUBLE SEAL

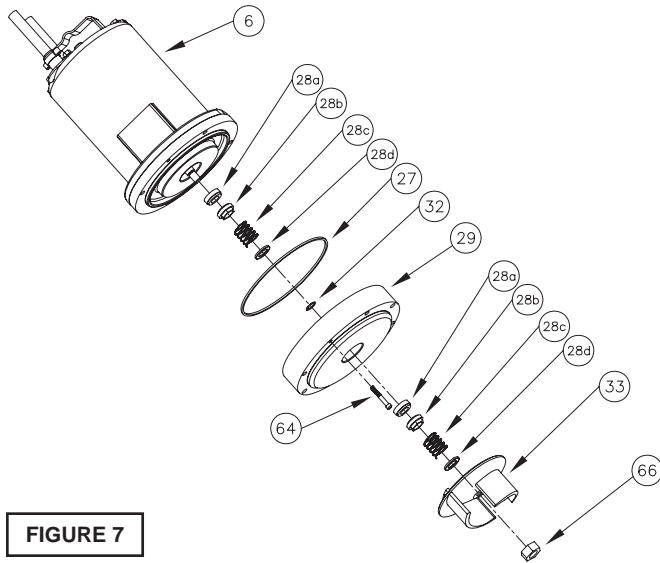

FIGURE 7

IMPORTANT ! - DO NOT hammer on the seal pusher- it will damage the seal face.

Make sure the stationary member is in straight. Slide a bullet over motor shaft. Lightly oil (**DO NOT use grease**) shaft, bullet and inner surface of bellows on rotating member (28b) see Figure 9. With lapped surface of rotating member (28b) facing inward toward stationary member, slide rotating member over bullet and onto shaft, using seal pusher, until lapped faces of (28a) and (28b) are together (see Figure 8).

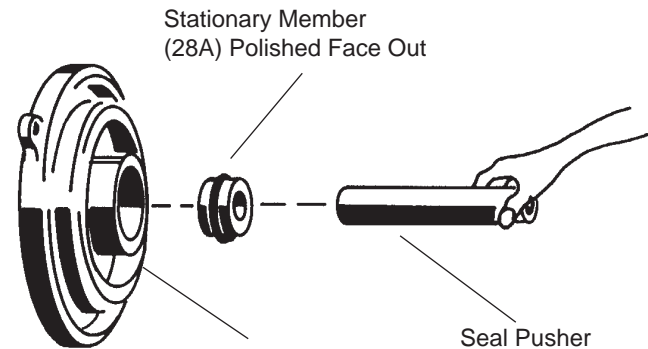

FIGURE 8 Seal Plate (5) for L series and (29) for DS series

It is extremely important to keep seal faces clean during assembly. Dirt particles lodged between these faces will cause the seal to leak. Place spring (28c) over shaft and in place on rotating member (28b), making sure it is seated on retainer and not cocked or resting on bellows tail. Slide retaining ring (28d) over shaft and let rest on spring (28c). Replace snap ring (32) in groove of shaft. Set square-ring (27) in groove on outer seal plate (29) and place outer seal plate (29) onto inner seal plate (5). Replace socket head cap screws (64) and torque to 60 in-lbs.

Outer Seal (All Units) - Press stationary member (28a) firmly into outer seal plate (5, or 29 on DS Units) as described above. Slide rotating member (28b) onto stationary member using seal pusher as described above. Place spring (28c) and retaining ring (28d) onto rotating member (28b). Assemble impeller and volute as outlined in paragraph F-2.2. Replace oil as outlined in paragraph F-1.4.

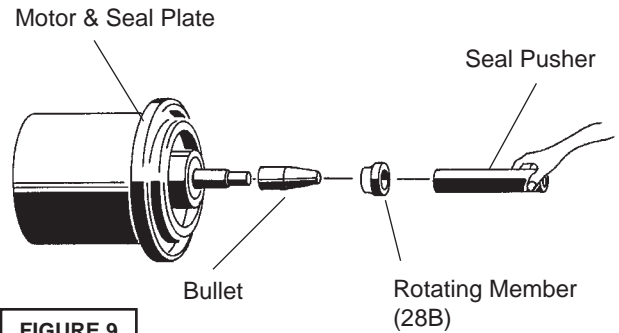

FIGURE 9

F-4) Motor and Bearing Service

F-4.1) Disassembly and Inspection:

To examine or replace the motor (7), capacitor (9, single phase units), controls (56, optional), and bearing (25), drain oil from motor as outlined in paragraph F-1.1. Disassemble volute and impeller as outlined in paragraph F-2.1 and disassemble shaft seal as outlined in paragraph F-3.1.

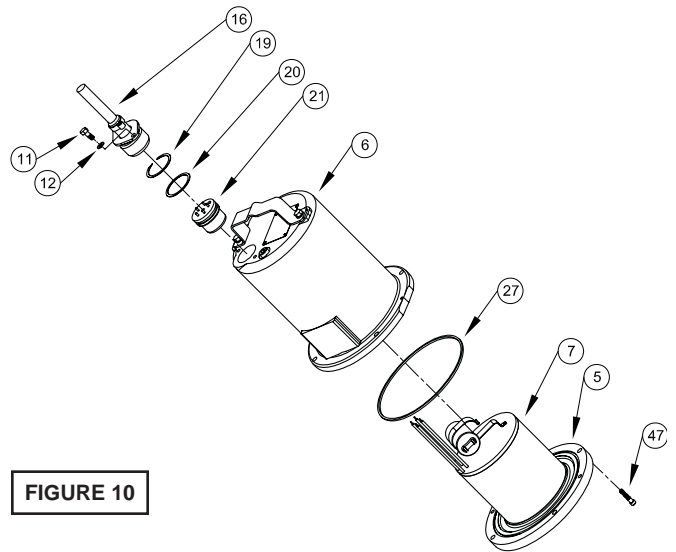

FIGURE 10

Position unit upright, using blocks to avoid resting unit on shaft. Unscrew cable hex bolts (11) and remove compression flange (16a) and power cord (16). Remove snap ring (19) with a flat head screwdriver. Pull the terminal block (21) out of the housing (6) using a T-bolt or a pair of pliers and a .25-20 screw in the threads of the terminal block (21). Be sure to leave slack on the motor leads connected underneath. Use needle nose pliers to pull each female connector off of the pins on the underside of the terminal block (21) see Figure 10. The unit voltage should be noted. Repeat cable and terminal block removal procedure for any control cables (56) if equipped. Remove socket head cap screws (47). Vertically lift the motor housing (6) from seal plate (5) by lifting handle (13). Inspect square ring (27) for damage or cuts. Remove the motor bolts and lift motor stator from seal plate (5). Disconnect capacitor leads from capacitor (9, single phase units). Examine bearing (25) and replace if required. If replacement is required, remove bearing (25) from motor shaft using a wheel puller or arbor press, see Figure 11.

Check motor capacitor (9, single phase units) with an Ohm

meter by first grounding the capacitor by placing a screwdriver across both terminals and then removing screwdriver. Connect Ohm meter (set on high scale) to terminals. If needle moves to infinity (∞) then drifts back, the capacitor is good. If needle does not move or moves to infinity (∞) and does not drift back, replace capacitor (9). If moisture sensors (4, optional) are damaged, disconnect leads by removing machine screws (45) and washers (46) from probes (4). Remove probes (4) from seal plate (5). To test the temperature sensor (50, optional), check for continuity between the black and white wires. If found to be defective, contact a motor service station or Barnes Pumps Service department. Inspect motor winding for shorts and check resistance values. Check rotor for wear. If rotor or the stator windings are defective, the complete motor must be replaced.

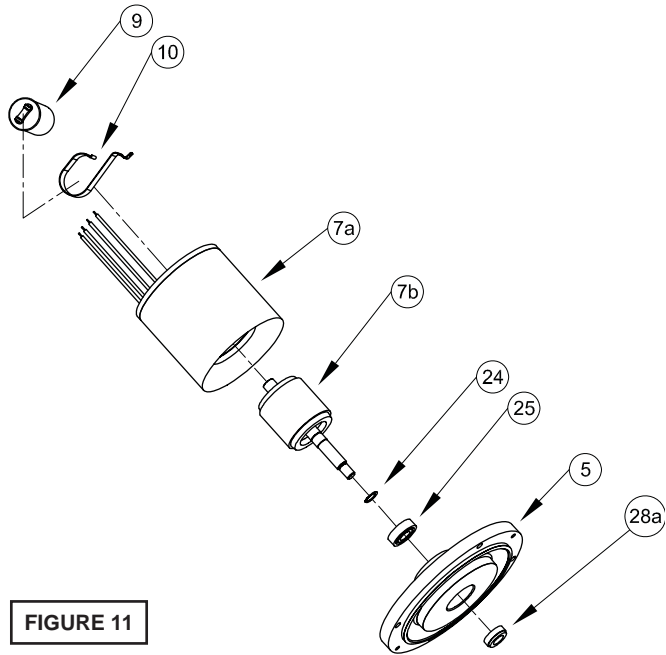

FIGURE 11

IMPORTANT! - All parts must be clean before reassembly.

F-4.2) Reassembly:

Moisture Sensors, DS Models - If pump is equipped with optional moisture sensors, reassemble by applying thread compound to threads on probes (4) and install in upper seal plate (5), see Figures 17 & 18. Connect wire assemblies (53) to probes (4) with washers (46) and machine screws (45).

Thermal Sensors- If pump is equipped with optional thermal sensors use terminal connectors (52) to connect wire assemblies (51) to sensor leads. If found to be defective, contact a motor service station or Barnes Pumps Service department.

Bearings- When replacing bearing, be careful not to damage the rotor or shaft threads. Clean the shaft thoroughly. Press bearing (25) on the motor shaft, position squarely onto the shaft applying force to the inner race of the bearing only, until bearing seats against the retaining ring (24) (Included with motor).

Motor- Slide lower bearing (25) and motor shaft squarely into the seal plate (5) until bearing seats on the bottom. Place stator over rotor, lining up motor bolts with holes in seal plate (5). Position capacitor (9, single phase units) so that it will lay on the opposite side of the cable entry bosses of the motor housing (6). Reconnect capacitor leads. Torque motor tie bolts to 17 in-lbs. Set square ring (27) in groove on seal plate (5).

F-4.3) Wiring Connections:

Check power cables (16) and control cable (56, if used), for cracks or damage and replace if required (see Figure 12). Make internal wiring connections which are independent of the terminal block as shown, using connectors (48) and wire assemblies (49) as required. Do not use wire nuts. Slip motor leads and ground wire into fiberglass sleeve. Lower motor housing (6) down onto seal plate (5) while aligning holes and stringing motor leads through the cable entry bore(s). (Slipping cords inside a 1 ft. length of .5" conduit makes this easier). Place socket head cap screws (47) through seal plate (5) into motor housing (6) and torque to 60 in-lbs. Reconnect motor and optional control leads to the underside of the terminal block(s) (21), (54 optional) as shown in Figure 13. Note that the pins are numbered underneath the terminal block. Place o-ring (20) into groove in terminal block and lubricate with dielectric oil.

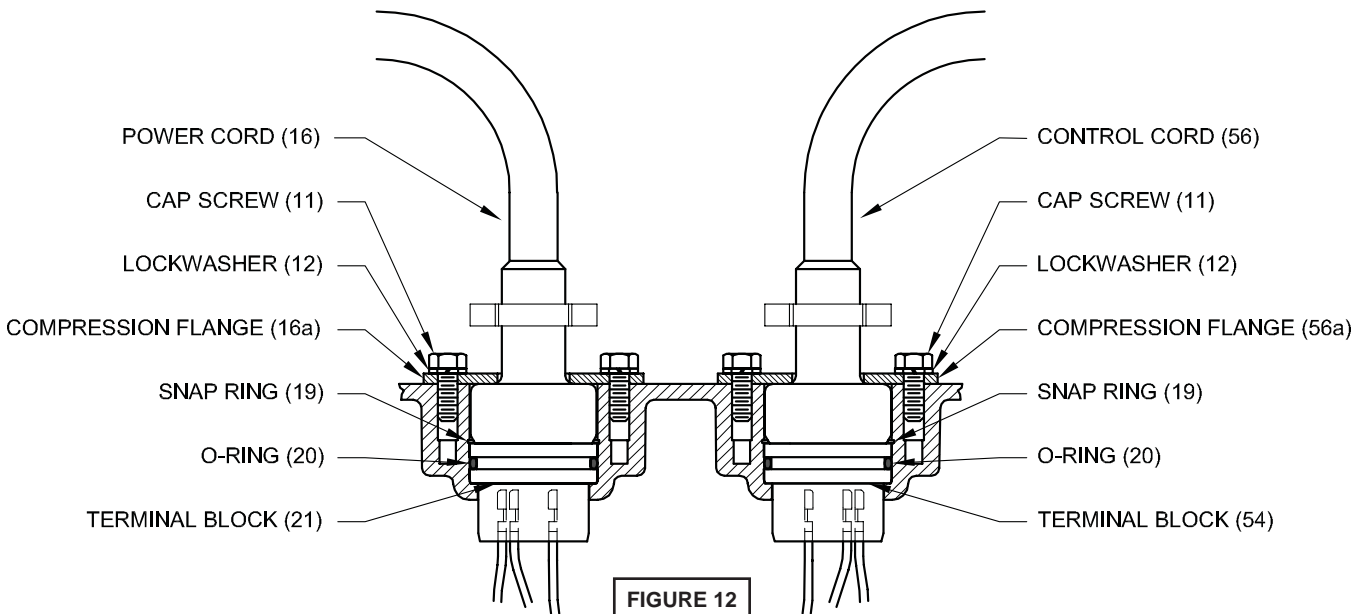
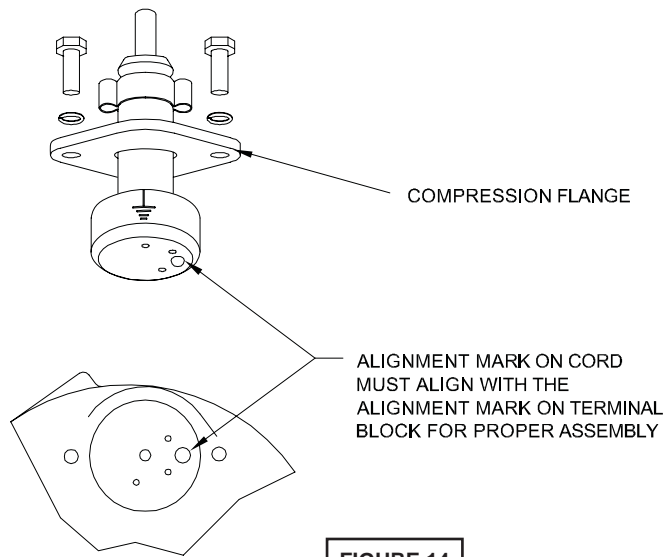

FIGURE 12

Press the terminal block (21) into the housing so it seats completely below the snap ring groove. Place snap ring (19) into groove in cable entry bore of housing. Repeat terminal



block installation for control cable, if equipped.

F-4.4) Cable Assemblies:

Power/Control Cable- Refill the cooling oil as outlined in paragraph F-1.3. Make wire connections as outlined in paragraph F-4.3. Insert female end of cable plug into housing bore aligning timing mark with hole in terminal block (21) see Figure 14. Compress cable plug with compression flange (16a) by tightening hex bolts (11) into the housing (6). Torque to 132 in-lbs.

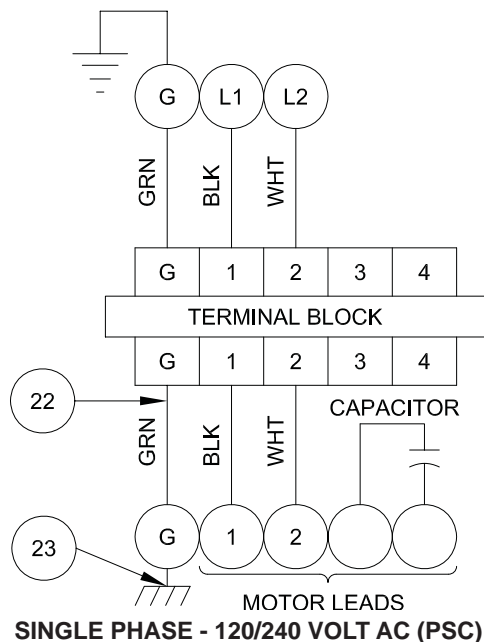

SINGLE PHASE - 120/240 VOLT AC (PSC)

FIGURE 14

SECTION: G REPLACEMENT PARTS

G-1 ORDERING REPLACEMENT PARTS:

When ordering replacement parts, ALWAYS furnish the following information:

1. Pump serial number and date code. (Paragraph G-4)
2. Pump model number. (Paragraph G-3)
3. Pump part number. (Paragraph G-2)
4. Part description.
5. Item part number.
6. Quantity required.
7. Shipping instructions.
8. Billing Instructions.

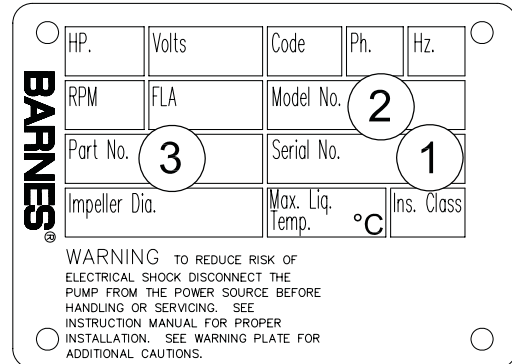

G-2 PART NUMBER:

The part number consists of a six (6) digit number, which appears in the catalog. A one or two letter suffix may follow this number to designate the design configuration. This number is used for ordering and obtaining information.

G-3 MODEL NUMBER:

This designation consists of numbers and letters which represent the discharge size, series, horsepower, motor phase and voltage, speed and pump design. This number is used for ordering and obtaining information.

G-4 SERIAL NUMBER:

The serial number block will consist of a six digit number, which is specific to each pump and may be preceded by a alpha character, which indicates the plant location. This number will also be suffixed with a four digit number, which indicates the date the unit was built (Date Code).

EXAMPLE: A012345 0490.

Reference the six digit portion (Serial Number) of this number when referring to the product.

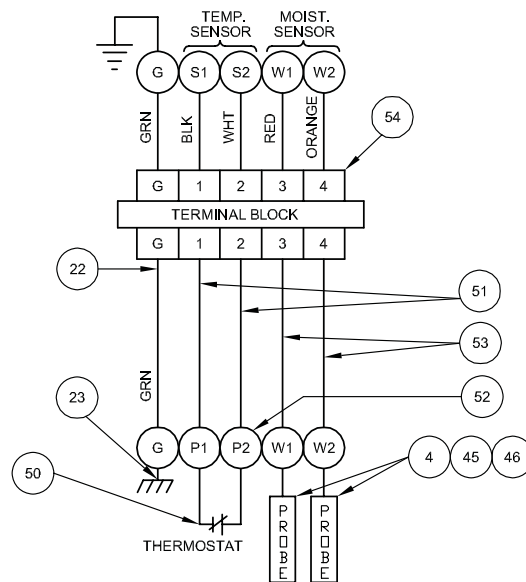
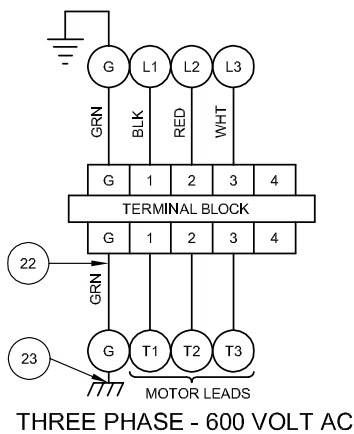
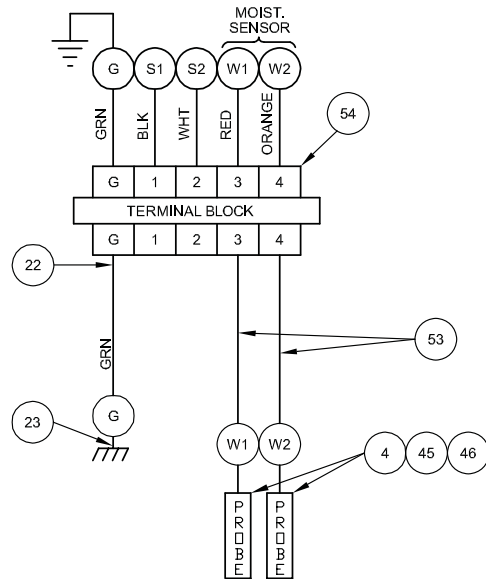
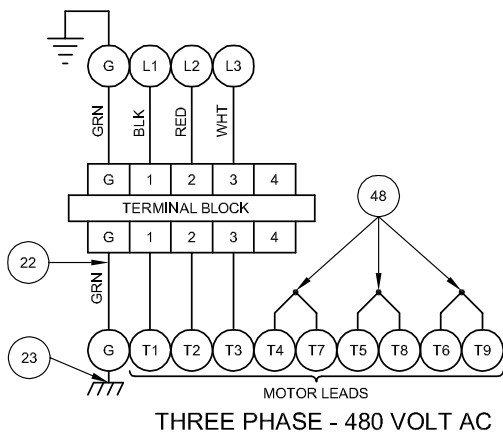
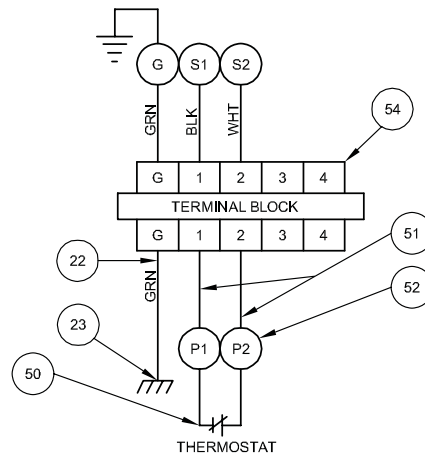
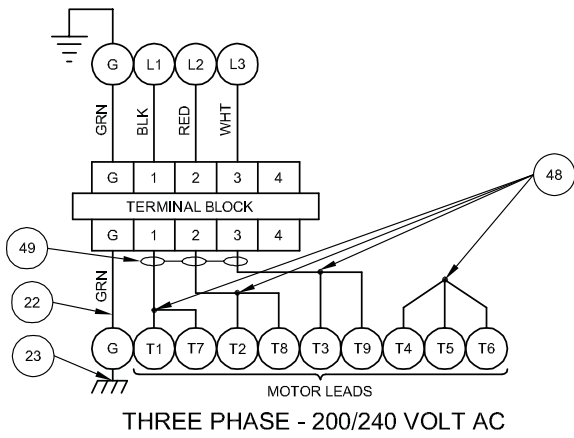

FIGURE 13 - CONTIUED

TROUBLE SHOOTING

CAUTION ! Always disconnect the pump from the electrical power source before handling.
 If the system fails to operate properly, carefully read instructions and perform maintenance recommendations.
 If operating problems persist, the following chart may be of assistance in identifying and correcting them:
 MATCH "CAUSE" NUMBER WITH CORRELATING "CORRECTION" NUMBER.

NOTE: Not all problems and corrections will apply to each pump model.

PROBLEM	CAUSE	CORRECTION
Pump will not run	<ol style="list-style-type: none"> 1. Poor electrical connection, blown fuse, tripped breaker or other interruption of power, improper power supply. 2. Motor or switch inoperative (to isolate cause, go to manual operation of pump). <ol style="list-style-type: none"> 2a. Float movement restricted. 2b. Switch will not activate pump or is defective. 3. Insufficient liquid level. 	<ol style="list-style-type: none"> 1. Check all electrical connections for security. Have electrician measure current in motor leads, if current is within $\pm 20\%$ of locked rotor Amps, impeller is probably locked. If current is 0, overload may be tripped. Remove power, allow pump to cool, then recheck current. <ol style="list-style-type: none"> 2a. Reposition pump or clean basin as required to provide adequate clearance for float. 2b. Disconnect level control. Set ohmmeter for a low range, such as 100 ohms full scale and connect to level control leads. Actuate level control manually and check to see that ohmmeter shows zero ohms for closed switch and full scale for open switch. (Float Switch). 3. Make sure liquid level is at least equal to suggested turn-on point.
Pump will not turn off	<ol style="list-style-type: none"> 2a. Float movement restricted. 2b. Switch will not activate pump or is defective. 4. Excessive inflow or pump not properly sized for application. 9. Pump may be airlocked. 14. H-O-A switch on panel is in "HAND" position 	<ol style="list-style-type: none"> 4. Recheck all sizing calculations to determine proper pump size. 5. Check discharge line for restrictions, including ice if line passes through or into cold areas. 6. Remove and examine check valve for proper installation and freedom of operation. 7. Open valve. 8. Check cutter for freedom of operation, security and condition. Clean cutter and inlet of any obstruction. 9. Loosen union slightly to allow trapped air to escape. Verify that turn-off level of switch is set so that the suction is always flooded. Clean vent hole.
Pump hums but does not run	<ol style="list-style-type: none"> 1. Incorrect voltage 8. Cutter jammed or loose on shaft, worn or damaged, inlet plugged. 	<ol style="list-style-type: none"> 10. Remove & examine for damage. Replace pump stator if required. 11. Repair fixtures as required to eliminate leakage.
Pump delivers insufficient capacity	<ol style="list-style-type: none"> 1. Incorrect voltage. 4. Excessive inflow or pump not properly sized for application. 5. Discharge restricted. 6. Check valve stuck closed or installed backwards. 7. Shut-off valve closed. 8. Cutter jammed or loose on shaft, worn or damaged, inlet plugged. 9. Pump may be airlocked. 10. Pump stator damaged/torn. 	<ol style="list-style-type: none"> 12. Check pump temperature limits & fluid temperature. 13. Replace portion of discharge pipe with flexible connector. 14. Turn to automatic position. 15. Check for leaks around basin inlet and outlets.
Pump cycles too frequently or runs periodically when fixtures are not in use	<ol style="list-style-type: none"> 6. Check valve stuck closed or installed backwards. 11. Fixtures are leaking. 15. Ground water entering basin. 	
Pump shuts off and turns on independent of switch, (trips thermal overload protector). CAUTION! Pump may start unexpectedly. Disconnect power supply.	<ol style="list-style-type: none"> 1. Incorrect voltage. 4. Excessive inflow or pump not properly sized for application. 8. Cutter jammed, loose on shaft, worn or damaged, inlet plugged. 12. Excessive water temperature. 	
Pump operates noisily or vibrates excessively	<ol style="list-style-type: none"> 4. Operating at too high a pressure. 5. Discharge restricted. 8. Cutter broken. 13. Piping attachments to building structure too rigid or too loose. 	

4SE- L Series, Single Seal

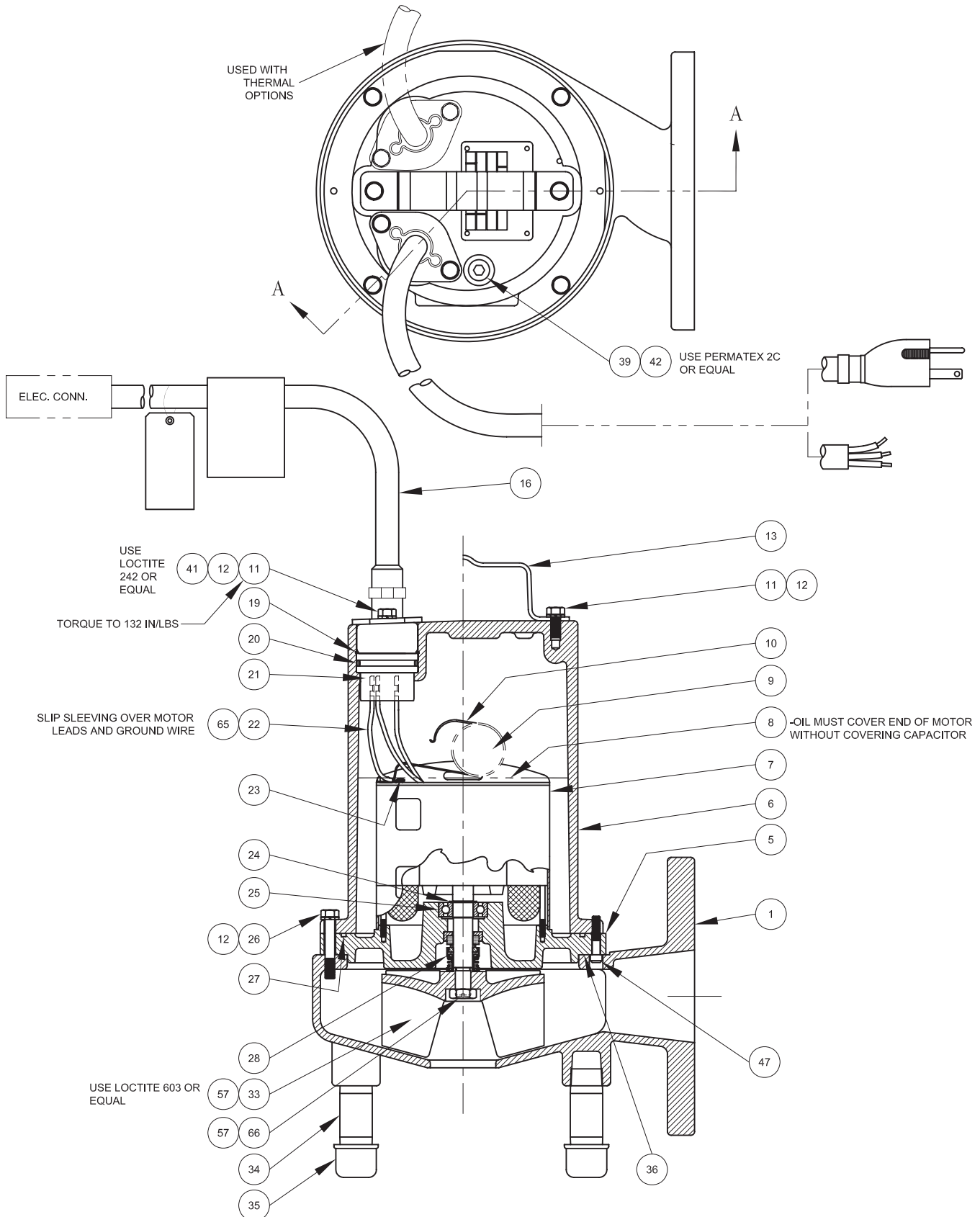

FIGURE 15

4SE- L Series, Single Seal

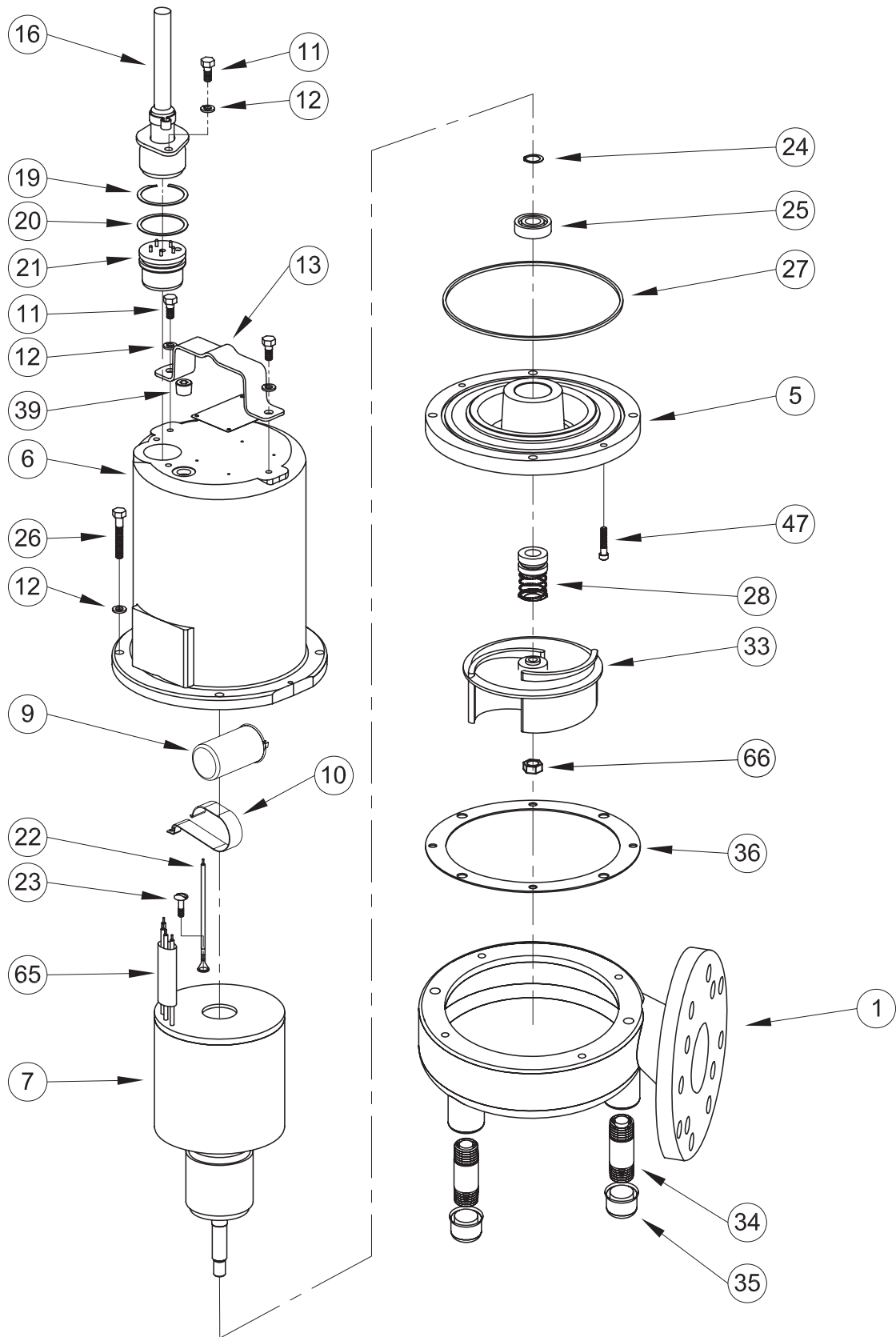

FIGURE 16

4SE-DS Series, Double Seal

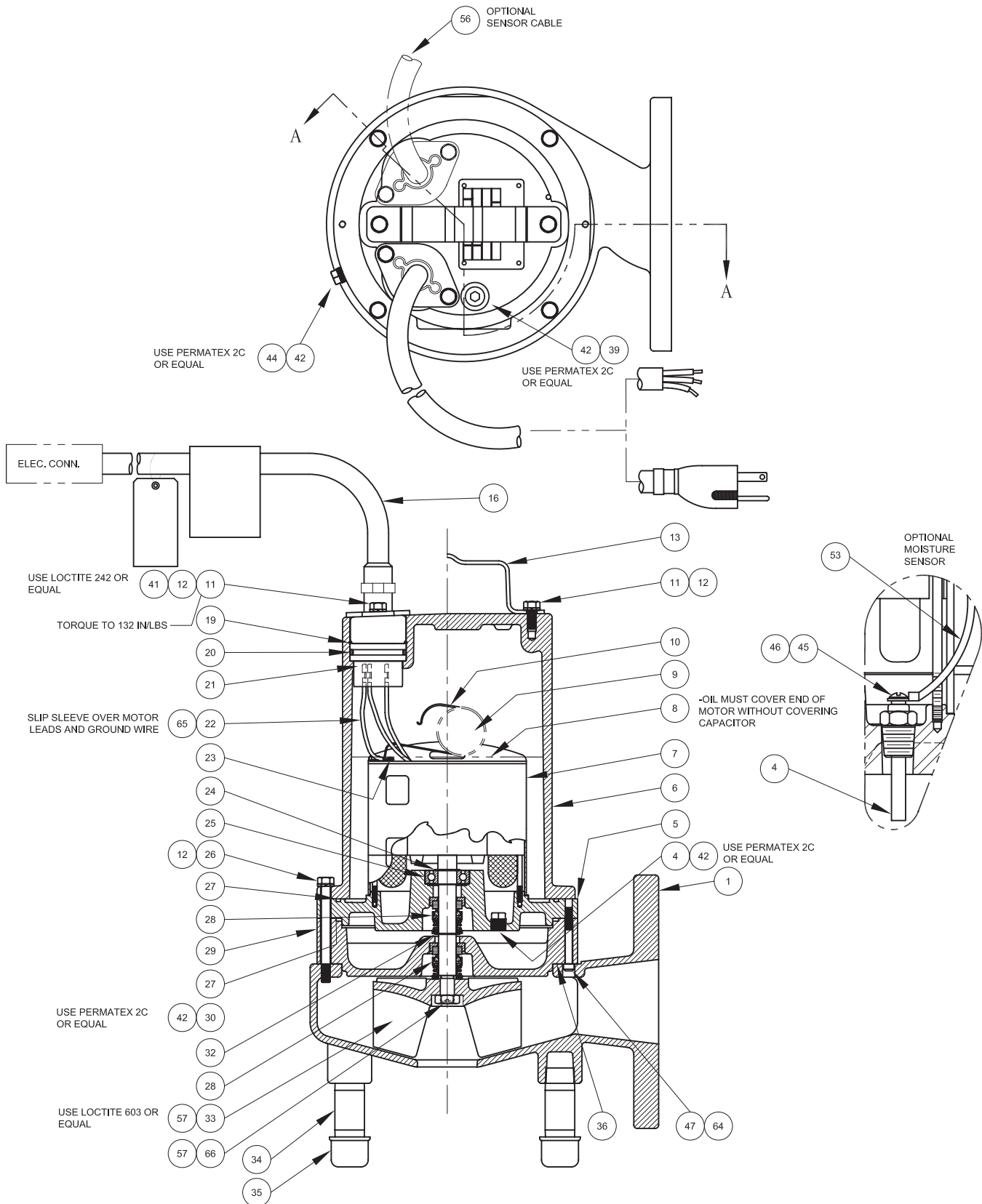

FIGURE 17

4SE-DS Series, Double Seal

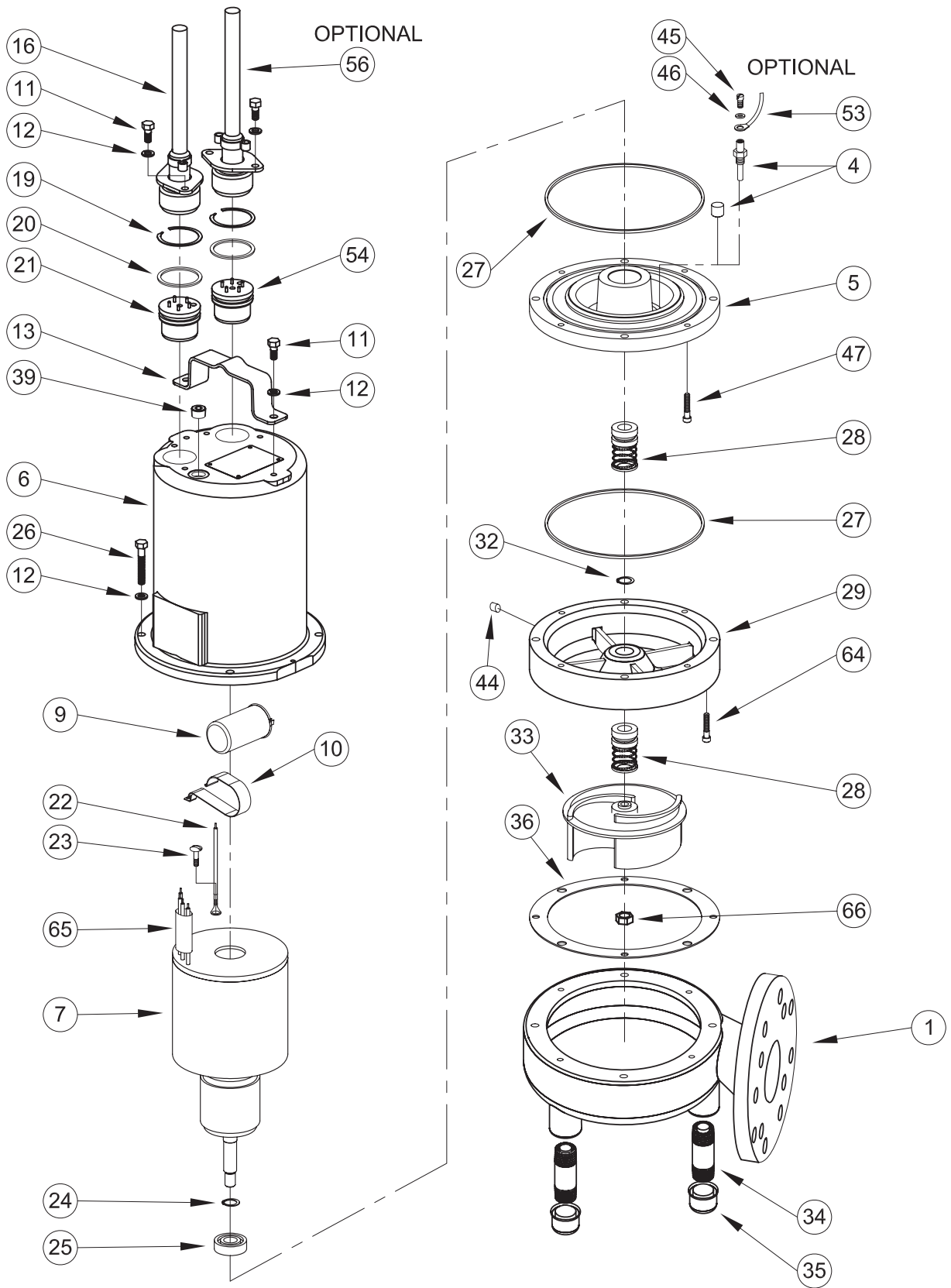

FIGURE 18

PARTS KITS

Seal Repair Kits:

Single SealP/N - 130180 (+) 20, 27, 28, 36

Double SealP/N - 130176 (†) 20, 27, 28, 32, 36

Service Kits:

Single Seal.....P/N - 130207 (◇) 19, 20, 22, 24, 25, 27, 28, 36, 49, 65, 66

Double SealP/N - 130172 (◆) 19, 20, 22, 24, 25, 27, 28, 32, 36, 44, 49, 65, 66

Seal Tool KitP/N - 107271

Pressure Gauge KitP/N - 085343

PARTS LIST

ITEM	QTY.	PART NO.	DESCRIPTION
1	1	103604	Volute
4	2	003217	Pipe Plug
	2	039383	Moisture Sensor Probes
5	1	084532	Seal Plate
		084906	Seal Plate
6	1	105196	Motor Housing
		105196HA	(Optional) for moisture and temp. sensors
7	1		Motor:
		030369BS	4SE914L
		030369BD	4SE914DS
		030370BS	4SE924L
		030370BD	4SE924DS
		071352BS	4SE994L, 4SE944L
		071352BD	4SE994DS, 4SE944DS
		092854BS	4SE954L
		092854BD	4SE954DS
		085472BS	4SE1474L
		085472BD	4SE1474DS
		029792BS	4SE1924L
		029792BD	4SE1924DS
		071354BS	4SE1494L, 4SE1444L, 4SE1994L, 4SE1944L
		071354BD	4SE1494DS, 4SE1444DS, 4SE1994DS, 4SE1944DS
		092855BS	4SE1454L, 4SE1954L
		092855BD	4SE1454DS, 4SE1954DS
8	96oz	029034	Oil
	120oz	029034	Oil
9	1	034964	Capacitor
10	1	039858	Capacitor Bracket
11	4	1-129-1	Hex. Hd. Cap Screw
	6	1-129-1	Hex. Hd. Cap Screw
12	8	026322	Lockwasher
	10	026322	Lockwasher
13	1	103503	Handle
16	1	See Table 2	Power Cable Set
16a	1	103582	Compression Flange
19	1	105197	◇ Snap Ring
	2	105197	◆ Snap Ring
20	1	2-31051-224	+◇ O-ring
	2	2-31051-224	†◆ O-ring
21	1	103584	Terminal Block
	1	103583	Terminal Block
22	1	105111	◇◆ Ground Wire Assembly
	2	105111	Ground Wire Assembly
23	1	016660	Screw #8-32 x .375" Lg.
24	1	085326	◇◆ Retaining Ring
25	1	017414	◇◆ Bearing
26	4	1-135-1	Cap Screw All single seal, 5/16-18 x 1.75" Lg., Stainless
	4	1-168-1	Cap Screw All double seal, 5/16-18 x 3.50" Lg., Stainless
27	1	027269	+ † ◆ Square Ring All single seal
	2	027269	◆ Square Ring All double seal

* Units with build code date (see section G-4) before -0901 may use capacitor part number, 070963 or the 034964 part number.

28	1		+ † ◊ ◆	Shaft Seal: (Qty 2 for DS) Carbon/Ceramic/Buna-N (STD) Tungsten/Tungsten/Buna-N Silicon Carbide/Silicon Carbide/Buna-N Carbon/Ceramic/Viton Tungsten/Tungsten/Viton Silicon Carbide/Silicon Carbide/Viton Silicon Carbide/Tungsten/Buna-N Carbon/Ni-Resistant/Buna-N Carbon/Ni-Resistant/Neoprene Carbon/Ni-Resistant/Viton	
29	1	103587		Seal Housing	All double seal
32	1	2-27008-62	† ◆	Retaining Ring	All double seal
33	1			Impeller, Cast Iron:	
		084346		6.00 Dia. (STD for 1.9 HP)	
		084346TA		5.88 Dia.	
		084346TB		5.75 Dia.	
		084346TC		5.63 Dia. (STD for 1.4 HP)	
		084346TD		5.50 Dia.	
		084346TE		5.38 Dia.	
		084346TF		5.25 Dia. (STD for .9 HP)	
		084346TG		5.13 Dia.	
		084346TH		5.00 Dia.	
		084346TJ		4.88 Dia.	
		084346TK		4.75 Dia.	
		084346TL		4.63 Dia.	
		084346TM		4.50 Dia.	
		084346TN		4.38 Dia.	
		084346TP		4.25 Dia.	
		084346TQ		4.13 Dia.	
		084346TR		4.00 Dia.	
34	3	005808		Nipple	
35	3	003479		Cap	
36	1	027344	+ † ◊ ◆	Gasket	
39	1	014270		Pipe Plug	.375" NPT, ZP
41	A/R			Loctite242	
42	A/R			Permatex2C	
44	1	003217	◆	Pipe Plug	All double seal, .25" NPT, ZP
45	2	5-32-6		Screw	(Optional) for moisture sensor, #6-32 x .25" Lg., ZP
46	2	052563		Lockwasher	(Optional) for moisture sensor, #6 Stl.
47	2	084948		Socket Head Screw	1/4-20 x 1.25" Lg., Stainless
48	4	105150		Terminal Connector	200-240V, 3Ph
	3	625-00163		Terminal Connector	480V, 3PH
49	3	105149	◊ ◆	Wire Assembly	200-240V, 3Ph
50	1	051621		Thermal Sensor	(Optional) for temperature sensor, (Not Shown)
51	2	105155		Wire Assembly	(Optional) for temperature sensor, (Not Shown)
52	2	625-00163		Terminal Connector	(Optional) for temperature sensor, (Not Shown)
53	2	105106		Wire Assembly	(Optional) for moisture sensor
54	1	103584		Terminal Block	Temperature sensor options
		103585			Moisture and temp. sensor options
56	1	See Table 2		Control Cable	Optional for moisture and/or temp. sensors
57	A/R			Loctite 603	
64	2	030337		Socket Head Cap Screw	All double seal, 1/4-20 x 2.00" Lg., Stainless
65	1	625-02117	◊ ◆	Sleeve, Fiberglass	
66	1	030068	◊ ◆	Jam Nut	½ - 20, S.S.

TABLE 2 - POWER & SENSOR CORD SETS					
CABLE LENGTH	ITEM #16 240 VOLT 1 PHASE	ITEM #16 240 VOLT 1 PHASE	ITEM #16 3 PHASE	ITEM #56 (OPTIONAL) Temperature 3 Phase	ITEM #56 (OPTIONAL) Moisture and Temperature Sensor 3 Phase or Moisture Sensor
8 FT	103756A	103741A	103742A	103741A	103740A
15 FT	103756	103741	103742	103741	103740
20 FT	103756XA	103741XA	103742XA	103741XA	103740XA
30 FT (Std)	103756XC	103741XC	103742XC	103741XC	103740XC
50 FT	103756XF	103741XF	103742XF	103741XF	103740XF
75 FT	103756XJ	103741XJ	103742XJ	103741XJ	103740XJ
100 FT	103756XL	103741XL	103742XL	103741XL	103740XL

BARNES®

BARNES®
PRESSURE **PS** SYSTEMS®

CROWN

burks®

WEINMAN®

DEMING®

PROSSER®

Limited 24 Month Warranty

Crane Pumps & Systems warrants that products of our manufacture will be free of defects in material and workmanship under normal use and service for twenty-four (24) months after manufacture date, when installed and maintained in accordance with our instructions. This warranty gives you specific legal rights, and there may also be other rights which vary from state to state. In the event the product is covered by the Federal Consumer Product Warranties Law (1) the duration of any implied warranties associated with the product by virtue of said law is limited to the same duration as stated herein, (2) this warranty is a LIMITED WARRANTY, and (3) no claims of any nature whatsoever shall be made against us, until the ultimate consumer, his successor, or assigns, notifies us in writing of the defect, and delivers the product and/or defective part(s) freight prepaid to our factory or nearest authorized service station. Some states do not allow limitations on how long an implied warranty lasts, so the above limitation may not apply. **THE SOLE AND EXCLUSIVE REMEDY FOR BREACH OF ANY AND ALL WARRANTIES WITH RESPECT TO ANY PRODUCT SHALL BE TO REPLACE OR REPAIR AT OUR ELECTION, F.O.B. POINT OF MANUFACTURE OR AUTHORIZED REPAIR STATION, SUCH PRODUCTS AND/OR PARTS AS PROVEN DEFECTIVE. THERE SHALL BE NO FURTHER LIABILITY, WHETHER BASED ON WARRANTY, NEGLIGENCE OR OTHERWISE.** Unless expressly stated otherwise, guarantees in the nature of performance specifications furnished in addition to the foregoing material and workmanship warranties on a product manufactured by us, if any, are subject to laboratory tests corrected for field performance. Any additional guarantees, in the nature of performance specifications must be in writing and such writing must be signed by our authorized representative. Due to inaccuracies in field testing if a conflict arises between the results of field testing conducted by or for user, and laboratory tests corrected for field performance, the latter shall control. **RECOMMENDATIONS FOR SPECIAL APPLICATIONS OR THOSE RESULTING FROM SYSTEMS ANALYSES AND EVALUATIONS WE CONDUCT WILL BE BASED ON OUR BEST AVAILABLE EXPERIENCE AND PUBLISHED INDUSTRY INFORMATION. SUCH RECOMMENDATIONS DO NOT CONSTITUTE A WARRANTY OF SATISFACTORY PERFORMANCE AND NO SUCH WARRANTY IS GIVEN.**

This warranty shall not apply when damage is caused by (a) improper installation, (b) improper voltage (c) lightning (d) excessive sand or other abrasive material (e) scale or corrosion build-up due to excessive chemical content. Any modification of the original equipment will also void the warranty. We will not be responsible for loss, damage or labor cost due to interruption of service caused by defective parts. Neither will we accept charges incurred by others without our prior written approval.

This warranty is void if our inspection reveals the product was used in a manner inconsistent with normal industry practice and/or our specific recommendations. The purchaser is responsible for communication of all necessary information regarding the application and use of the product. **UNDER NO CIRCUMSTANCES WILL WE BE RESPONSIBLE FOR ANY OTHER DIRECT OR CONSEQUENTIAL DAMAGES, INCLUDING BUT NOT LIMITED TO TRAVEL EXPENSES, RENTED EQUIPMENT, OUTSIDE CONTRACTOR FEES, UNAUTHORIZED REPAIR SHOP EXPENSES, LOST PROFITS, LOST INCOME, LABOR CHARGES, DELAYS IN PRODUCTION, IDLE PRODUCTION, WHICH DAMAGES ARE CAUSED BY ANY DEFECTS IN MATERIAL AND/OR WORKMANSHIP AND/OR DAMAGE OR DELAYS IN SHIPMENT. THIS WARRANTY IS EXPRESSLY IN LIEU OF ANY OTHER EXPRESS OR IMPLIED WARRANTY, INCLUDING ANY WARRANTY OF MERCHANTABILITY OR FITNESS FOR A PARTICULAR PURPOSE.**

No rights extended under this warranty shall be assigned to any other person, whether by operation of law or otherwise, without our prior written approval.

CRANE®

A Crane Co. Company

PUMPS & SYSTEMS

420 Third Street
Piqua, Ohio 45356
Phone: (937) 778-8947
Fax: (937) 773-7157
www.cranepumps.com

83 West Drive, Brampton
Ontario, Canada L6T 2J6
Phone: (905) 457-6223
Fax: (905) 457-2650

**IMPORTANT!
WARRANTY REGISTRATION**

Your product is covered by the enclosed Warranty.
To complete the Warranty Registration Form go to:

<http://www.cranepumps.com/ProductRegistration/>

If you have a claim under the provision of the warranty, contact your local
Crane Pumps & Systems, Inc. Distributor.

RETURNED GOODS

**RETURN OF MERCHANDISE REQUIRES A "RETURNED GOODS AUTHORIZATION".
CONTACT YOUR LOCAL CRANE PUMPS & SYSTEMS, INC. DISTRIBUTOR.**



**Products Returned Must Be Cleaned, Sanitized,
Or Decontaminated As Necessary Prior To Shipment,
To Insure That Employees Will Not Be Exposed To Health
Hazards In Handling Said Material. All Applicable Laws
And Regulations Shall Apply.**