

## 2" Self-Priming Engine Driven Trash Pumps



Model 3932-95

- **Cast Iron Construction**
- **Viton®/Silicon Carbide Mechanical Seal**
- **2" NPT Port Sizes**
- **Self-Priming up to 20 Feet with Built-In Viton® Check Valve**
- **Engine Options: Honda, Briggs & Stratton or Hatz Diesel**
- **Solids Handling and Dirty Water Design**
- **Maximum Solids Handling up to 1" Diameter**
- **Maximum Head up to 105 Ft.**
- **Maximum Flow up to 185 GPM**
- **Heavy Duty Steel Roll Frame Included with Optional Wheel Kit Available**

AMT Cast Iron Engine Driven Trash pumps are designed for applications which require high flow, solids handling capability and abrasion resistance. This series of pumps are also good for chemical spraying, handling and processing. These pumps are constructed of heavy duty CNC machined cast iron components featuring removable/replaceable cast iron volute and impeller. Simple four bolt clean out design permits easy removal of trash and debris without disconnecting hoses. Pumps are designed to handle liquids with solids content or dissolved solids and debris. Pumps are available with gasoline overhead valve or diesel engines from various engine manufacturers.

Performance of Engine Driven Trash Pumps

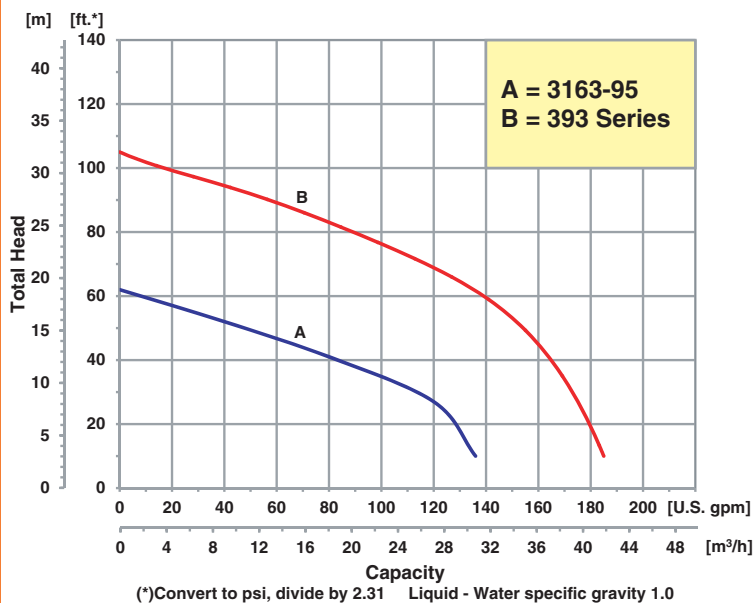

## Pump Dimensional & Specification Data

Model	Curve	Port	Driver	Seal	Run Time (Hours)	Tank Size (Gal./Ltr.)	Ship Wt. (Lbs.)
<b>3163-95</b>	A	2" NPT	Briggs & Stratton	Viton®/ SIC	1.2	0.52/2.0	80
<b>3930-95</b>	B	2" NPT	B & S Vanguard▲	Viton®/ SIC	1.3	0.87/3.3	110
<b>3932-95</b>	B	2" NPT	Honda GX160▲	Viton®/ SIC	2.0	0.82/3.1	105
<b>3930-D5</b>	B	2" NPT	Hatz Diesel 1B20	Viton®/ SIC	2.7	1.32/5.0	140

**Construction: Cast Iron**

**Maximum Solids Handling Capacity: 1" Diameter**

▲ Oil Alert Included

**Model 3163-95**

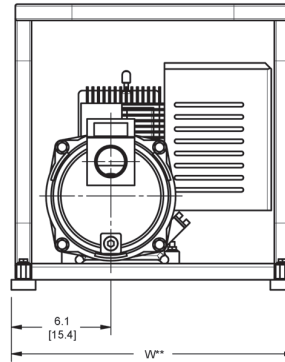
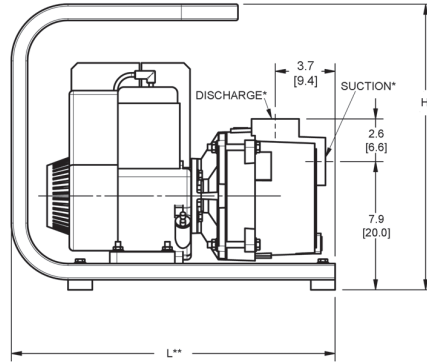

**Model 393 Series**

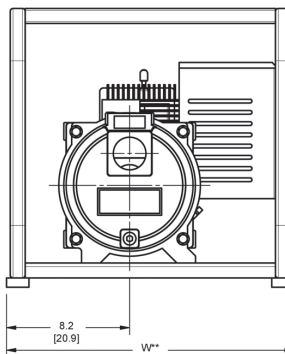
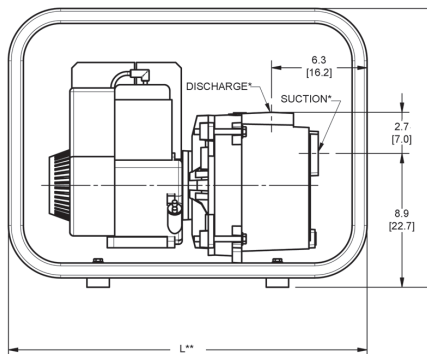

Model	HP Class*	SUC*	DIS*	L**	W**	H
<b>3163-95</b>	4 HP	2	2	20.0 [50.8]	17.5 [44.5]	17.6 [44.8]
<b>393 Series</b>	5 HP GAS	2	2	24.0 [61.0]	19.2 [48.7]	18.6 [47.2]
<b>393 Series</b>	5 HP DIESEL	2	2	31.0 [78.7]	22.5 [57.1]	23.6 [59.9]

(♦) HP Class represents market category and is not intended to define actual horsepower

(\*) Standard NPT (Female) pipe thread.

(\*\*) This dimension may vary due to engine manufacturer's specifications.

NOTE: Dimensions are in inches (centimeters) and have a tolerance of ± 1/8".

**Optional Wheel Kit**  
For Roll Frame Pumps

Model	Features	Ship Wt.
<b>C402-90</b>	Includes 10" semi-pneumatic tires on steel wheels with steel clamps and handles for universal mounting to frame.	25

## Standard Features

- (2) NPT Pipe Nipples & 2" Street Elbow Included
- Viton®/Silicon Carbide Mechanical Seal
- Viton® O-ring and Casing Seal
- Self-priming to 20 Feet with Built-in Viton® Check Valve
- Stainless Steel Shaft Sleeve
- Steel Suction Strainer Included
- Cast Iron Replaceable Volute/Wearplate and Impeller
- Maximum Temperature 180° F
- Maximum Working Pressure 75 PSI
- Heavy Duty Steel Roll Frame Included
- B & S Vanguard and Honda Engines are Overhead Valve (OHV) Designs with Low Oil Alert
- QSP – Quick Ship Pumps