

Ampco Centrifugal Pumps

DATA SHEET

MODEL ZC2 1½ X 1¼
NICKEL ALUMINUM BRONZE

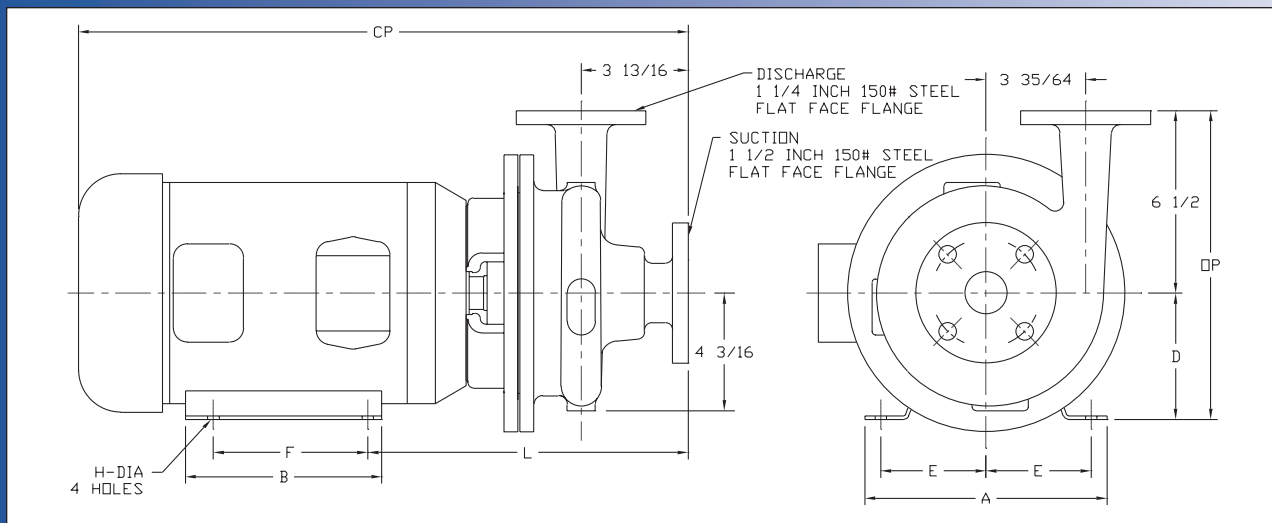
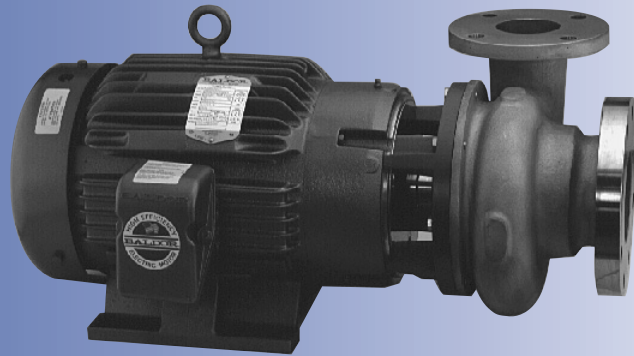

X	TEFC MOTOR			DIMENSIONS IN INCHES (For Reference Only)								APPROX. WEIGHT (LBS)	
	HP	RPM	FRAME	A	B	D	E	F	H	L	CP		OP
	1	1750	143JM	6-1/2	6	3-1/2	2-3/4	4	11/32	10-7/8	19-3/16	10	110
	1-1/2	1750	145JM	6-1/2	6	3-1/2	2-3/4	5	11/32	10-7/8	19-3/16	10	114
	2	1750	145JM	6-1/2	6	3-1/2	2-3/4	5	11/32	10-7/8	19-3/16	10	120
	2	3500	145JM	6-1/2	6	3-1/2	2-3/4	5	11/32	10-7/8	19-3/16	10	120
	3	3500	145JM	6-1/2	6	3-1/2	2-3/4	5	11/32	10-7/8	19-3/16	10	146
	5	3500	184JM	8-5/8	6-1/2	4-1/2	3-3/4	5-1/2	13/32	11-1/2	22	11	159
	7-1/2	3500	213JM	9-5/8	8-1/8	5-1/4	4-1/4	5-1/2	13/32	12-7/16	24-3/4	11-3/4	227

MATERIAL SPECIFICATIONS

PART NAME	NICKEL ALUMINUM BRONZE
Casing, Cover & Impeller	AMPCO® 483
Wear Ring	AMPCO® 18
Motor Shaft	Steel
Shaft Sleeve	AMPCO® 18
Adapter	Cast Iron



Ampco Centrifugal Pumps

**MODEL ZC2 1½ X 1¼
NICKEL ALUMINUM BRONZE**

Curves show approximate characteristics based on clear 68° water. Rated point is guaranteed.

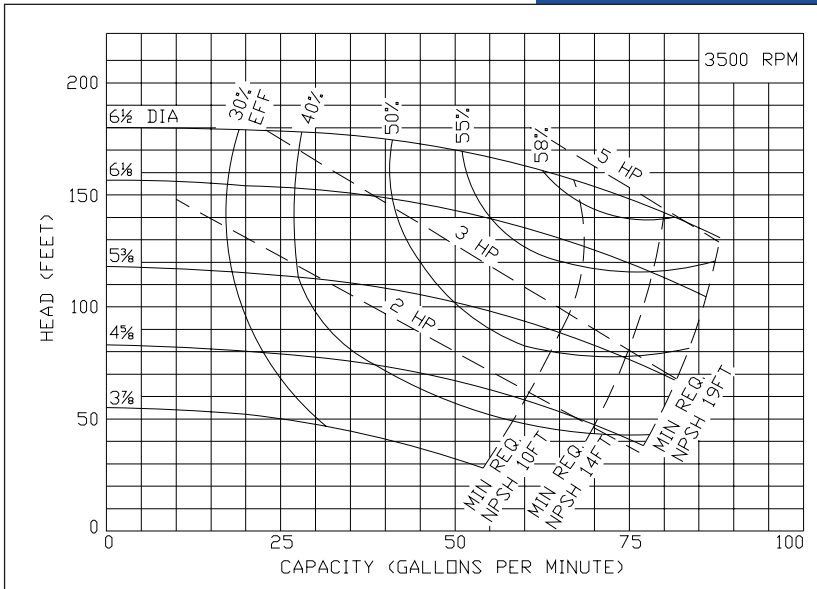

Heavy-duty Z Series pumps have maximum wall thickness and 150 lb. flat faced flanged connections.

Seal options include Type 21, Type 1 and Type 9 with choice of sealing materials.

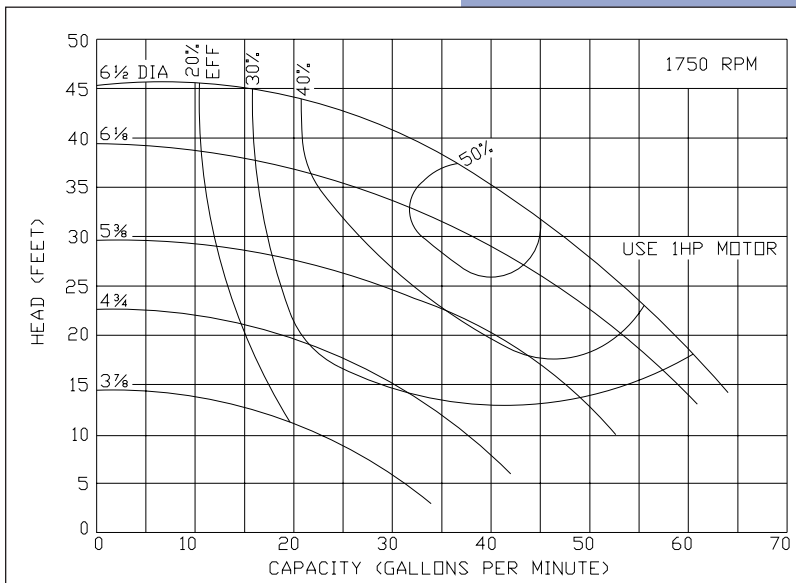
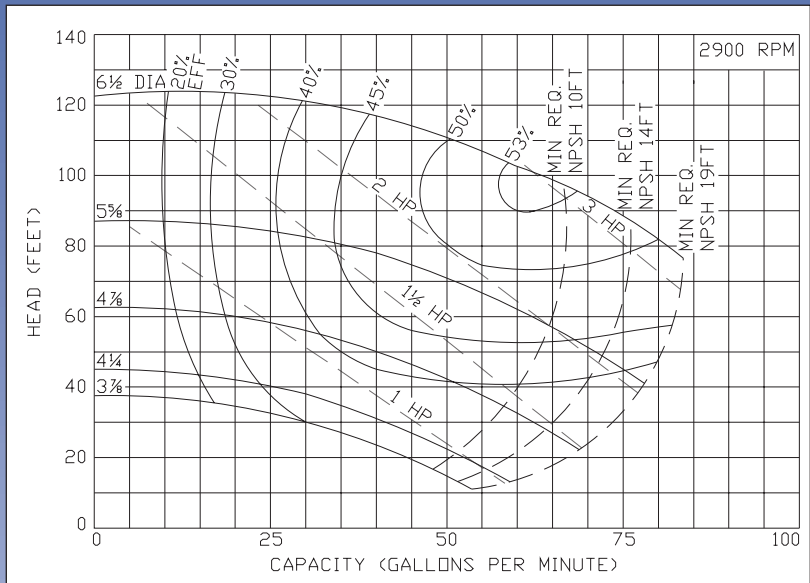

Ampco Pumps Company

4424 West Mitchell Street
Milwaukee, Wisconsin 53214
PHONE (414) 643-1852
FAX (414) 643-4452

Ampco Centrifugal Pumps

DATA SHEET

MODEL ZC2 1 1/2 X 1 1/4
STAINLESS STEEL

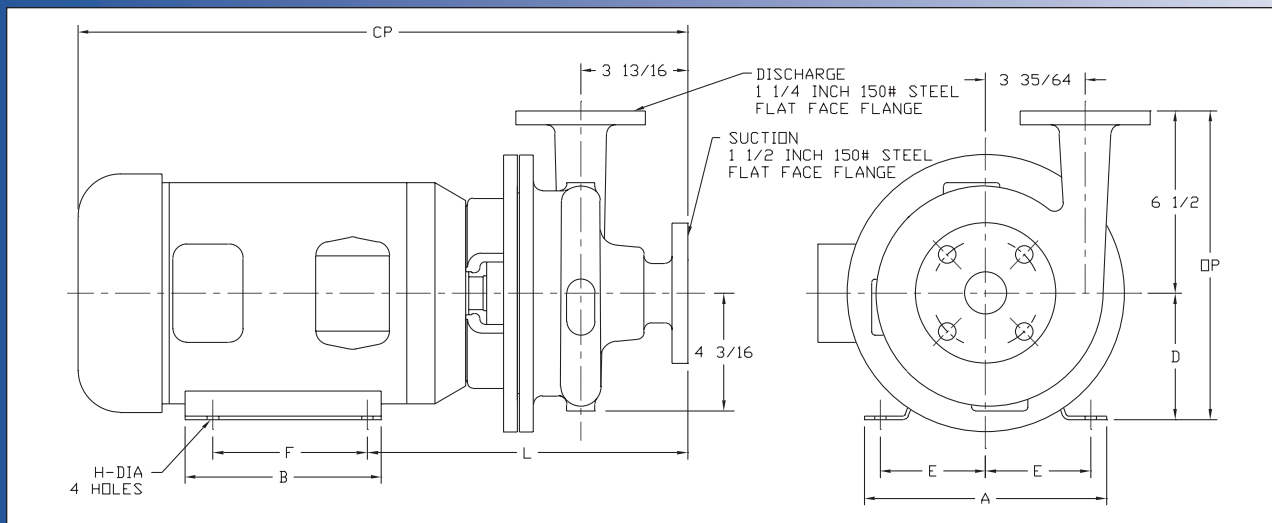
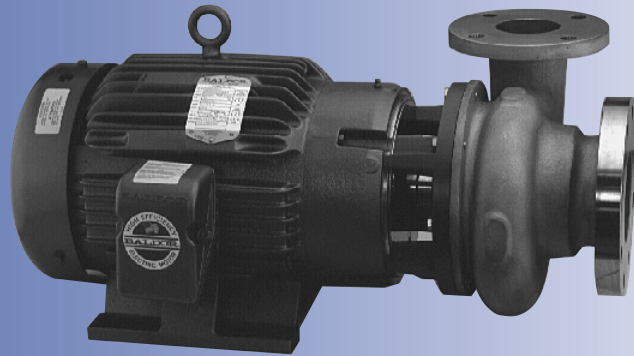

TEFC MOTOR			DIMENSIONS IN INCHES (For Reference Only)									APPROX. WEIGHT (LBS)
HP	RPM	FRAME	A (max)	B (max)	D	E	F	H	L	CP	OP	
1	1750	143JM	6-1/2	6	3-1/2	2-3/4	4	11/32	10-7/8	19-3/16	10	110
1-1/2	1750	145JM	6-1/2	6	3-1/2	2-3/4	5	11/32	10-7/8	19-3/16	10	114
2	1750	145JM	6-1/2	6	3-1/2	2-3/4	5	11/32	10-7/8	19-3/16	10	120
2	3500	145JM	6-1/2	6	3-1/2	2-3/4	5	11/32	10-7/8	19-3/16	10	120
3	3500	145JM	6-1/2	6	3-1/2	2-3/4	5	11/32	10-7/8	19-3/16	10	146
5	3500	184JM	8-5/8	6-1/2	4-1/2	3-3/4	5-1/2	13/32	11-1/2	22	11	159
7-1/2	3500	213JM	9-5/8	8-1/8	5-1/4	4-1/4	5-1/2	13/32	13	25	11-3/4	227

MATERIAL SPECIFICATIONS

PART NAME	STAINLESS STEEL
Casing, Cover & Impeller	316 Stainless
Wear Ring	316 Stainless
Motor Shaft	Steel
Shaft Sleeve	316 Stainless
Adapter	Cast Iron

* Also available in Duplex 2205

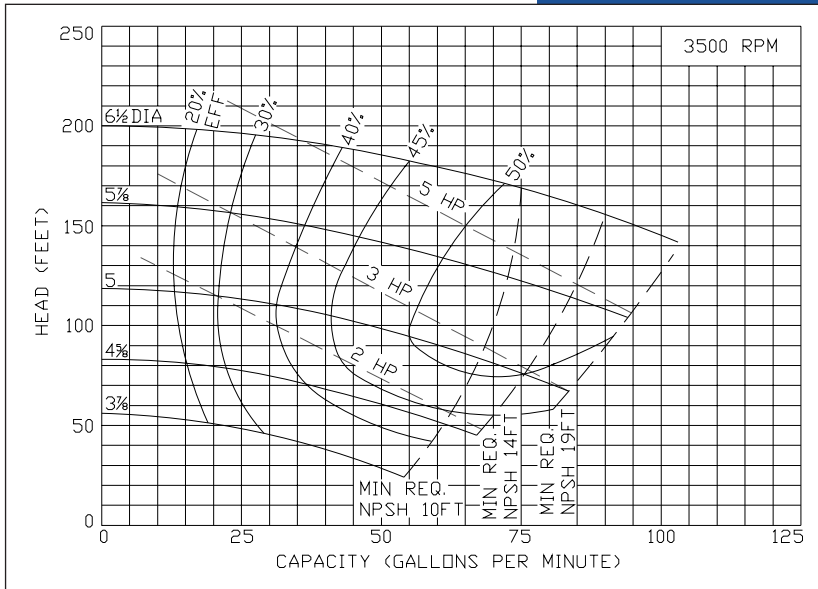

Ampco Centrifugal Pumps

MODEL ZC2 1 1/2 X 1 1/4
STAINLESS STEEL

Curves show approximate characteristics based on clear 68° water. Rated point is guaranteed.

Heavy-duty Z Series pumps have maximum wall thickness and 150 lb. flat faced flanged connections.

Seal options include Type 21, Type 1 and Type 9 with choice of sealing materials.

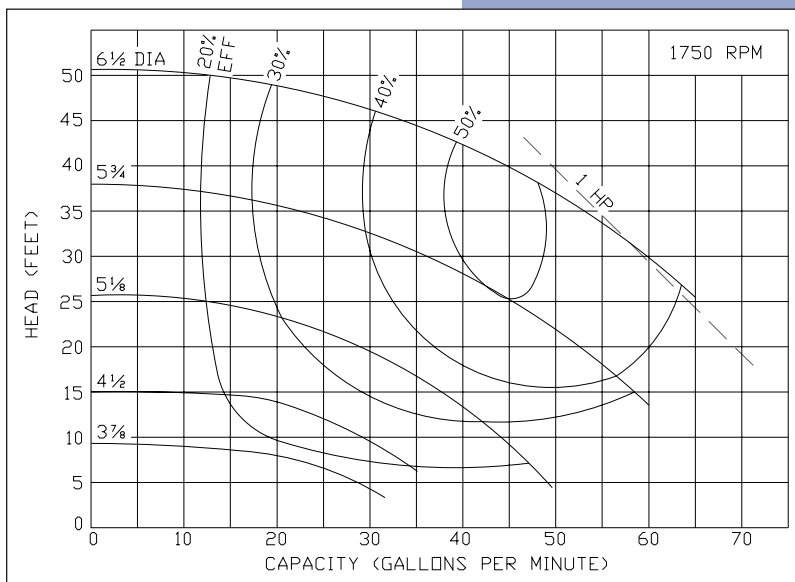
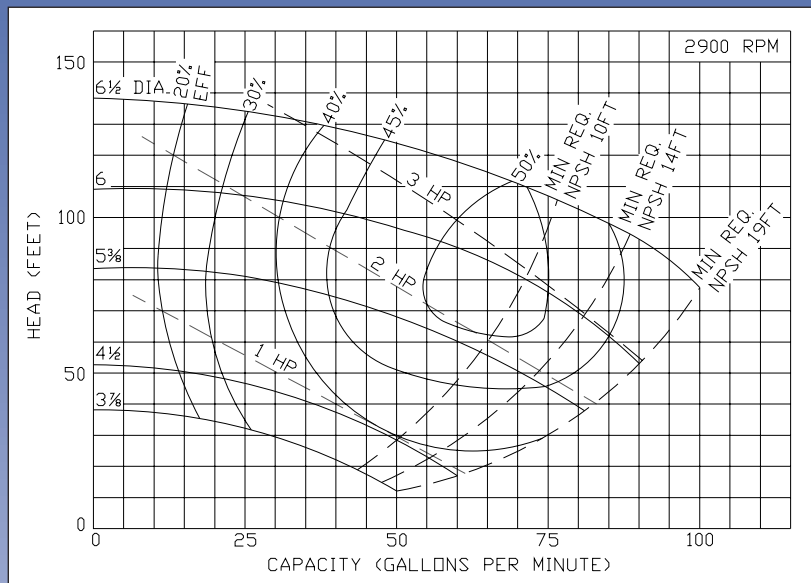

Ampco Pumps Company

4424 West Mitchell Street
Milwaukee, Wisconsin 53214
PHONE (414) 643-1852
FAX (414) 643-4452

Ampco Centrifugal Pumps

DATA SHEET

MODEL ZC2/ZCH2 1½X1½

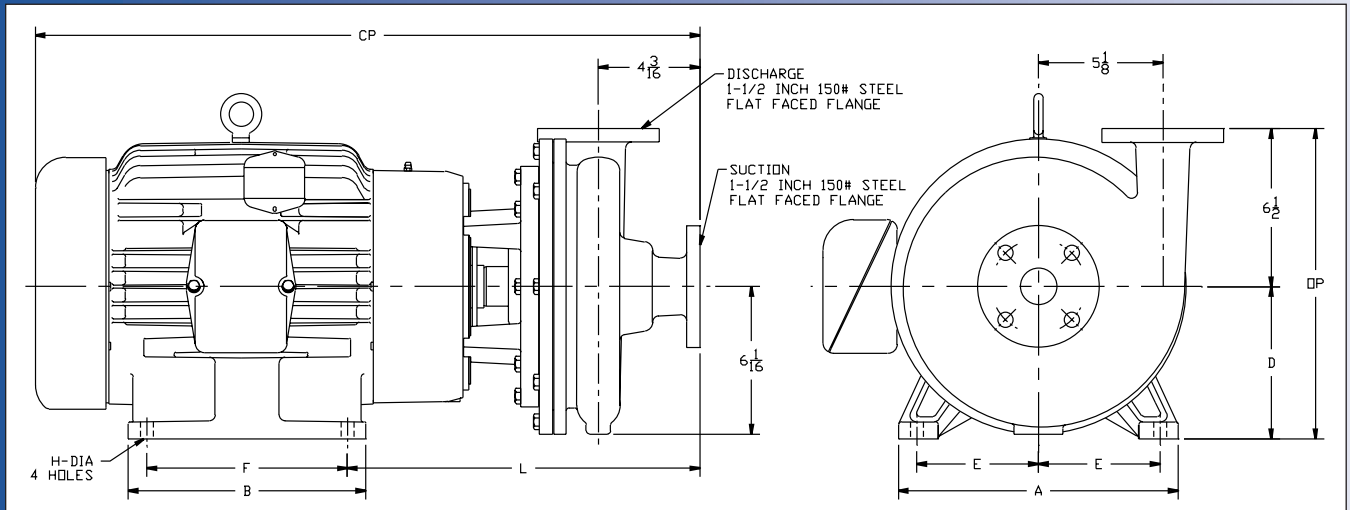
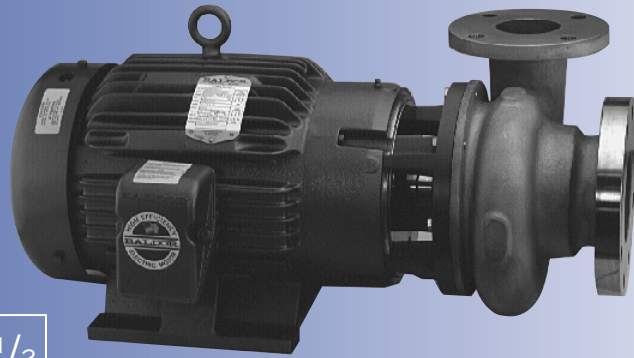

TEFC MOTOR			DIMENSIONS IN INCHES (For Reference Only)									APPROX. WEIGHT (LBS)
HP	RPM	FRAME	A (typ)	B (typ)	D	E	F	H	L	CP	OP	
1	1750	143JM	6-1/2	6	3-1/2	2-3/4	4	11/32	11-3/8	19-11/16	10	135
1-1/2	1750	145JM	6-1/2	6	3-1/2	2-3/4	5	11/32	11-3/8	19-11/16	10	139
2	1750	145JM	6-1/2	6	3-1/2	2-3/4	5	11/32	11-3/8	19-11/16	10	146
3	1750	182JM	8-5/8	6-1/2	4-1/2	3-3/4	4-1/2	13/32	12	21-3/32	11	155
5	3500	184JM	8-5/8	6-1/2	4-1/2	3-3/4	5-1/2	13/32	12	22-7/16	11	189
7-1/2	3500	213JM	9-5/8	8-1/8	5-1/4	4-1/4	5-1/2	13/32	13	25-5/16	11-3/4	257
10	3500	215JM	9-5/8	8-1/8	5-1/4	4-1/4	7	13/32	13	25-5/16	11-3/4	275
15	3500	254JM	11-1/2	9-3/4	6-1/4	5	8-1/4	17/32	14-1/2	27-5/16	12-3/4	389
20	3500	256JM	11-1/2	11-1/2	6-1/4	5	10	17/32	14-1/2	29-3/32	12-3/4	427

MATERIAL SPECIFICATIONS

PART NAME	NICKEL ALUMINUM BRONZE	STAINLESS STEEL
Casing, Cover & Impeller	AMPCO® 483	316 Stainless
Wear Rings	AMPCO® 18	316 Stainless
Motor Shaft	Steel	Steel
Shaft Sleeve	AMPCO® 18	316 Stainless
Adapter	Cast Iron	Cast Iron

* Also available in Duplex 2205

Ampco Centrifugal Pumps

MODEL ZC2/ZCH2 1½X1½

Curves show approximate characteristics based on clear 68° water. Rated point is guaranteed.

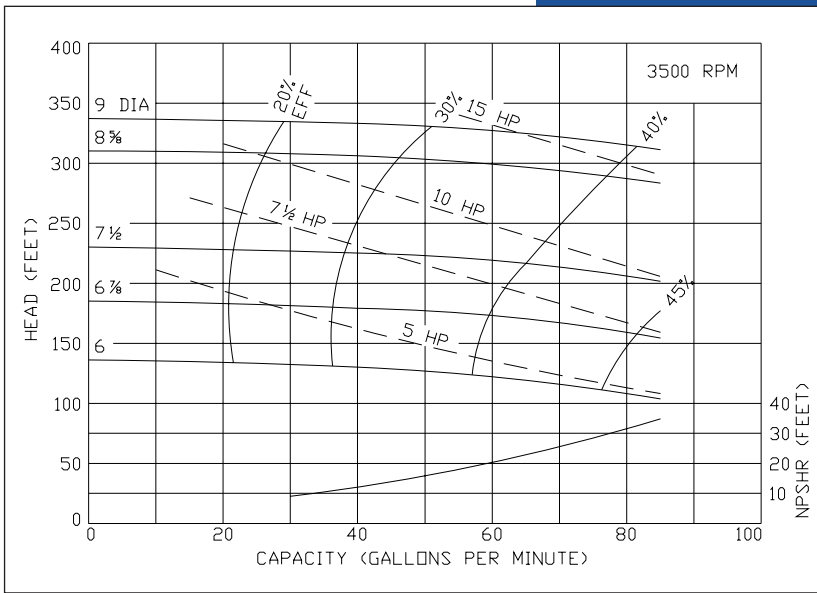

Heavy-duty Z Series pumps have maximum wall thickness and 150 lb. flat faced flanged connections.

Seal options include Type 21, Type 1 and Type 9 with choice of sealing materials.

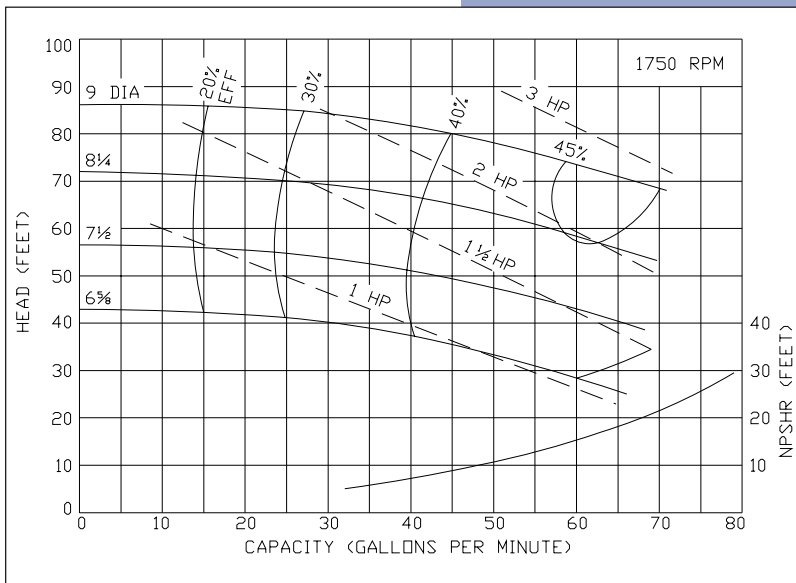
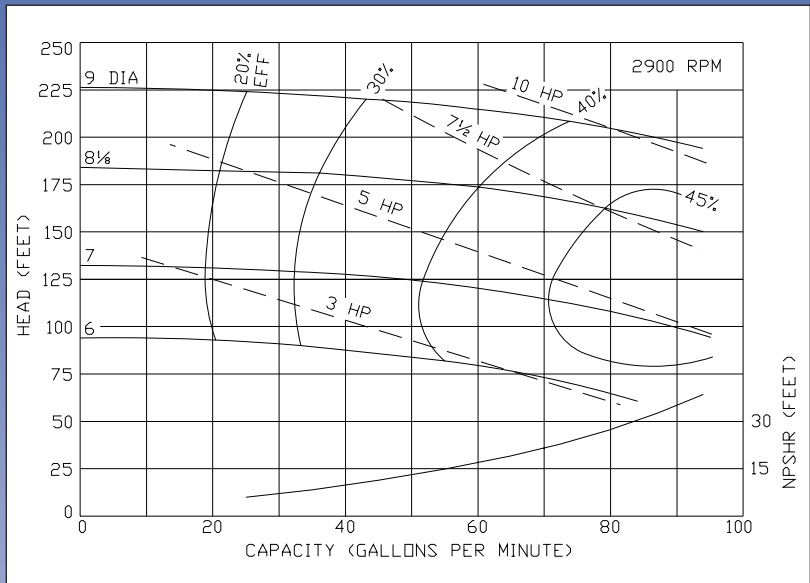

Ampco Pumps Company

4424 West Mitchell Street
 Milwaukee, Wisconsin 53214
 PHONE (414) 643-1852
 FAX (414) 643-4452

Ampco Centrifugal Pumps

DATA SHEET

MODEL ZC2 2 X 1 1/2

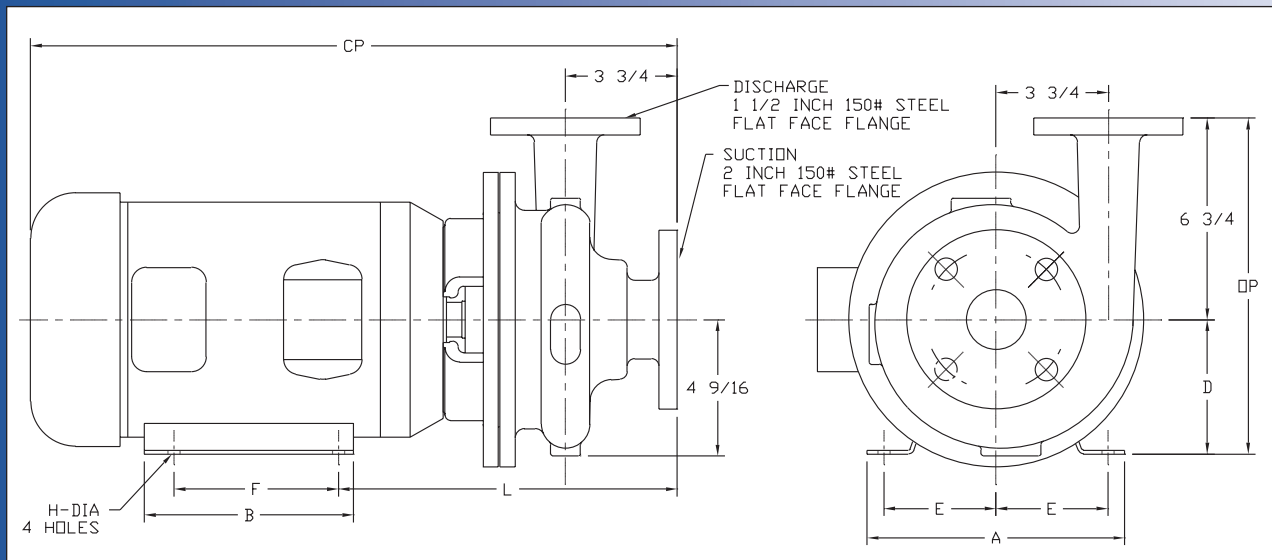
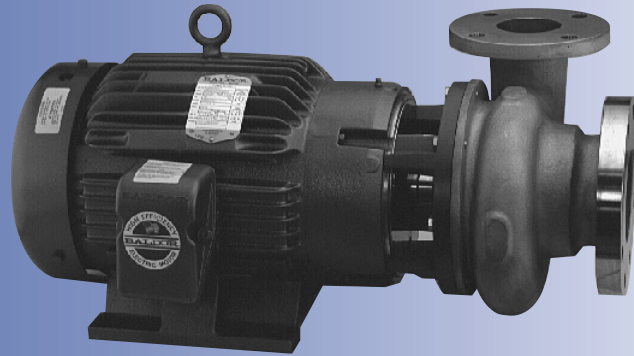

TEFC MOTOR			DIMENSIONS IN INCHES (For Reference Only)									APPROX. WEIGHT (LBS)
HP	RPM	FRAME	A (max)	B (max)	D	E	F	H	L	CP	OP	
1	1750	143JM	6-1/2	6	3-1/2	2-3/4	4	11/32	10-3/16	19-1/8	10-1/4	112
1-1/2	1750	145JM	6-1/2	6	3-1/2	2-3/4	5	11/32	10-3/16	19-1/8	10-1/4	116
2	1750	145JM	6-1/2	6	3-1/2	2-3/4	5	11/32	10-13/16	19-1/8	10-1/4	122
2	3500	145JM	6-1/2	6	3-1/2	2-3/4	5	11/32	10-13/16	19-1/8	10-1/4	122
3	3500	145JM	6-1/2	6	3-1/2	2-3/4	5	11/32	10-13/16	19-1/8	10-1/4	148
5	3500	184JM	8-5/8	6-1/2	4-1/2	3-3/4	5-1/2	13/32	11-7/16	21-15/16	11-1/4	161
7-1/2	3500	213JM	9-5/8	8-1/8	5-1/4	4-1/4	5-1/2	13/32	12-3/16	24-3/4	12	229
10	3500	215JM	9-5/8	8-1/8	5-1/4	4-1/4	7	13/32	12-3/16	24-3/4	12	247

MATERIAL SPECIFICATIONS

PART NAME	NICKEL ALUMINUM BRONZE	STAINLESS STEEL
Casing, Cover & Impeller	AMPCO® 483	316 Stainless
Wear Ring	AMPCO® 18	316 Stainless
Motor Shaft	Steel	Steel
Shaft Sleeve	AMPCO® 18	316 Stainless
Adapter	Cast Iron	Cast Iron

* Also available in Duplex 2205

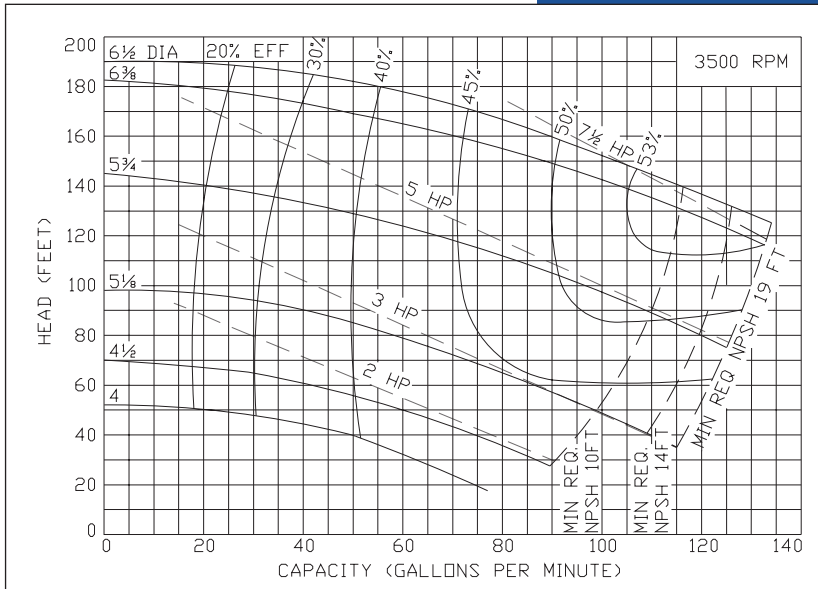

Ampco Centrifugal Pumps

MODEL ZC2 2 X 1 1/2

Curves show approximate characteristics based on clear 68° water. Rated point is guaranteed.

Heavy-duty Z Series pumps have maximum wall thickness and 150 lb. flat faced flanged connections.

Seal options include Type 21, Type 1 and Type 9 with choice of sealing materials.

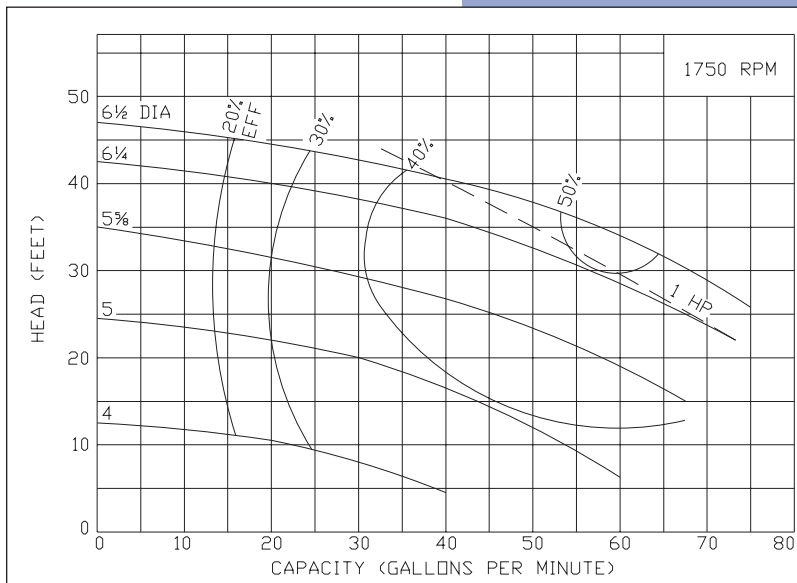
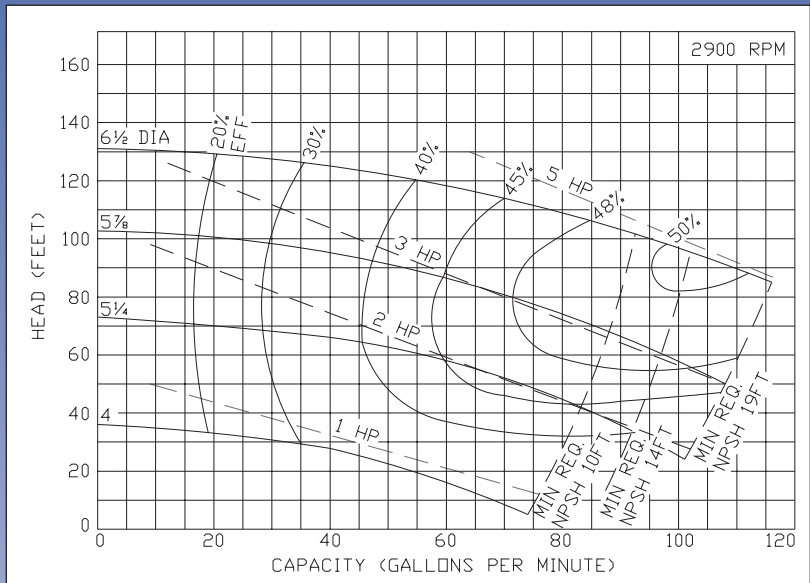

Ampco Pumps Company

4424 West Mitchell Street
 Milwaukee, Wisconsin 53214
 PHONE (414) 643-1852
 FAX (414) 643-4452

Ampco Centrifugal Pumps

DATA SHEET

MODEL ZC2/ZCH2 2X2

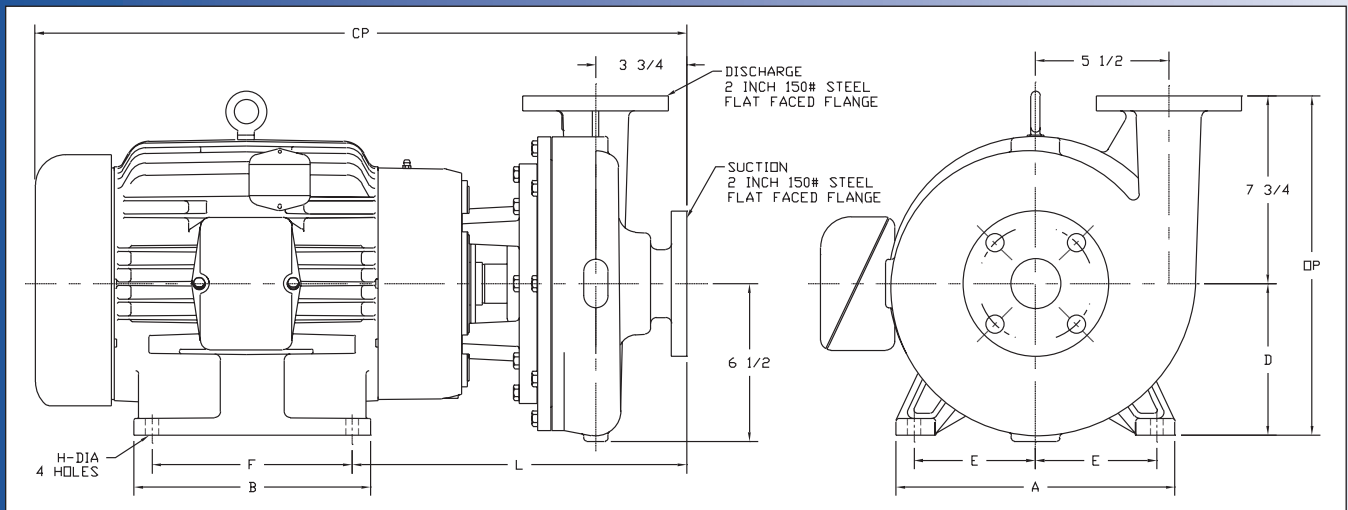
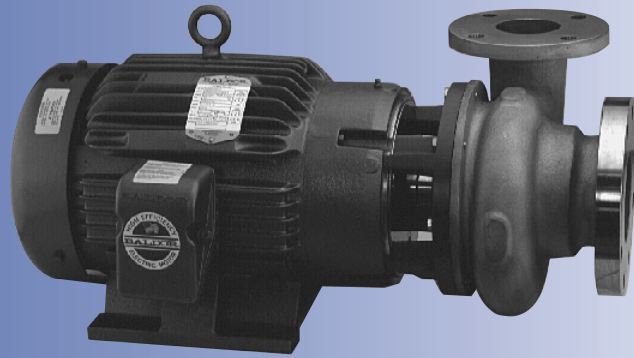

TEFC MOTOR			DIMENSIONS IN INCHES (For Reference Only)									APPROX. WEIGHT (LBS)
HP	RPM	FRAME	A (typ)	B (typ)	D	E	F	H	L	CP	OP	
1-1/2	1750	145JM	6-1/2	6	3-1/2	2-3/4	5	11/32	10-15/16	19-1/4	11-1/4	155
2	1750	145JM	6-1/2	6	3-1/2	2-3/4	5	11/32	10-15/16	19-1/4	11-1/4	162
3	1750	182JM	8-5/8	6-1/2	4-1/2	3-3/4	4-1/2	13/32	11-9/16	20-5/8	12-1/4	171
5	1750	184JM	8-5/8	6-1/2	4-1/2	3-3/4	4-1/2	13/32	11-9/16	22-1/8	12-1/4	195
7-1/2	1750	213JM	9-1/2	8	5-1/4	4-1/4	5-1/2	13/32	12-9/16	23-5/8	13	246
15	3500	254JM	11-1/2	9-3/4	6-1/4	5	8-1/4	17/32	14-1/32	26-7/8	14	405
20	3500	256JM	11-1/2	11-1/2	6-1/4	5	10	17/32	14-1/32	28-5/8	14	443
25	3500	284JM	12-3/4	12-3/4	7	5-1/2	9-1/2	17/32	14-1/32	32-1/4	14-3/4	591
30	3500	286JM	12-3/4	12-3/4	7	5-1/2	11	17/32	14-1/32	32-7/8	14-3/4	652
40	3500	324JM	14-1/2	14	8	6-1/4	10-1/2	21/32	14-17/32	34-1/8	15-3/4	747

MATERIAL SPECIFICATIONS

PART NAME	NICKEL ALUMINUM BRONZE	STAINLESS STEEL
Casing, Cover & Impeller	AMPCO® 483	316 Stainless
Wear Rings	AMPCO® 18	316 Stainless
Motor Shaft	Steel	Steel
Shaft Sleeve	AMPCO® 18	316 Stainless
Adapter	Cast Iron	Cast Iron

* Also available in Duplex 2205

Ampco Centrifugal Pumps

MODEL ZC2/ZCH2 2X2

Curves show approximate characteristics
based on clear 68° water.
Rated point is guaranteed.

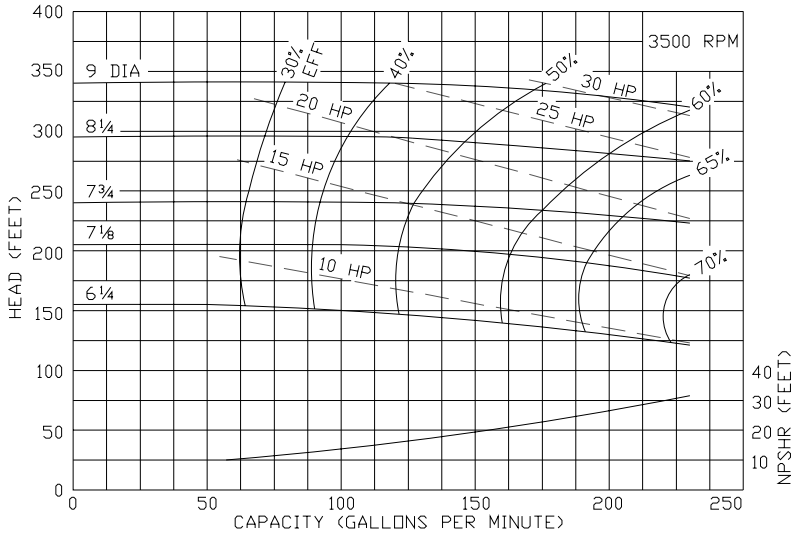

Heavy-duty Z Series pumps
have maximum wall
thickness and 150 lb. flat
faced flanged connections.

Seal options include Type
21, Type 1 and Type 9 with
choice of sealing materials.

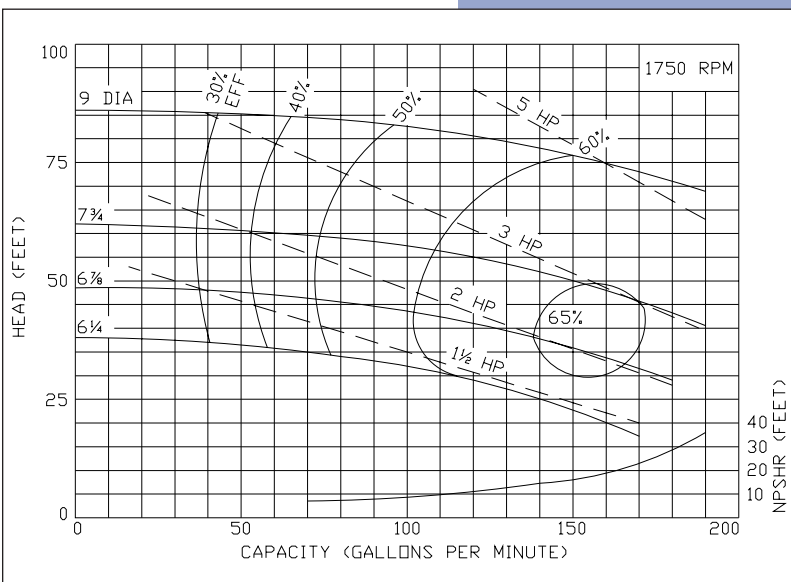
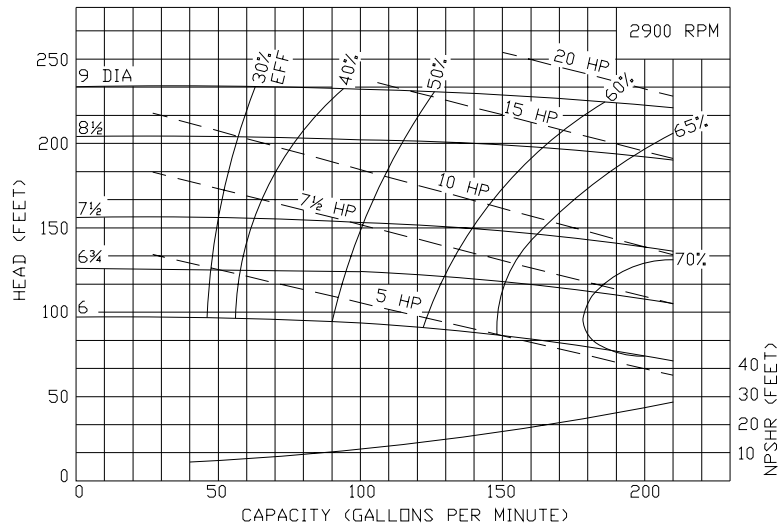

Ampco Pumps Company

4424 West Mitchell Street
Milwaukee, Wisconsin 53214
PHONE (414) 643-1852
FAX (414) 643-4452

Ampco Centrifugal Pumps

DATA SHEET

MODEL ZC2 2 1/2 X 2

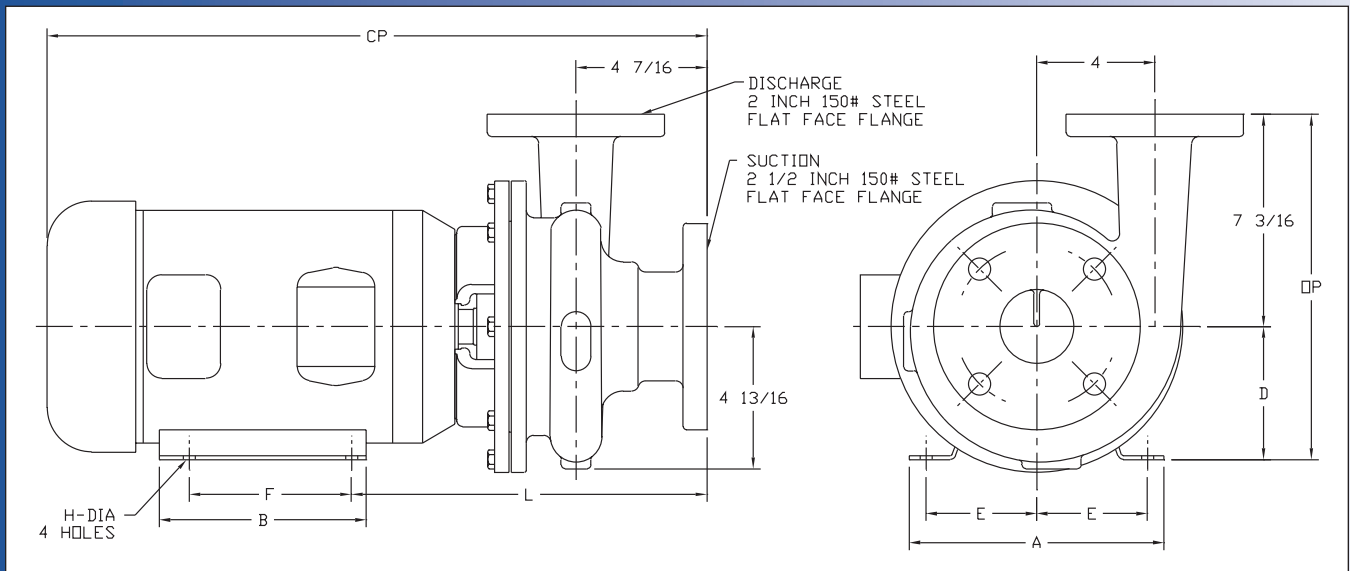
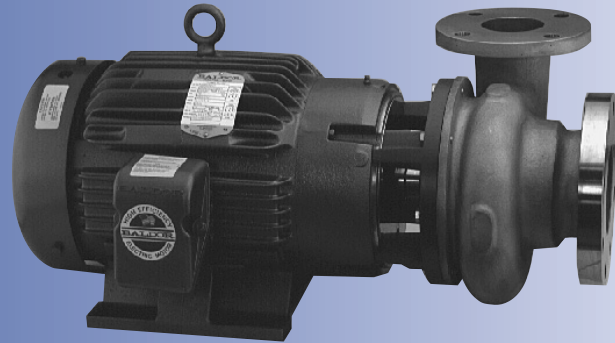

TEFC MOTOR			DIMENSIONS IN INCHES (For Reference Only)									APPROX. WEIGHT (LBS)
HP	RPM	FRAME	A (max)	B (max)	D	E	F	H	L	CP	OP	
1	1750	143JM	6-1/2	6	3-1/2	2-3/4	4	11/32	11-1/2	19-3/4	10-11/16	118
1-1/2	1750	145JM	6-1/2	6	3-1/2	2-3/4	5	11/32	11-1/2	19-3/4	10-11/16	122
2	1750	145JM	6-1/2	6	3-1/2	2-3/4	5	11/32	11-1/2	19-3/4	10-11/16	128
3	1750	182JM	8-5/8	6-1/2	4-1/2	3-3/4	4-1/2	13/32	12-1/8	21-1/8	11-11/16	154
5	3500	184JM	8-5/8	6-1/2	4-1/2	3-3/4	5-1/2	13/32	12-1/8	22-1/2	10-11/16	167
7-1/2	3500	213JM	9-5/8	8-1/8	5-1/4	4-1/4	5-1/2	13/32	13-1/8	25-3/8	12-7/16	235
10	3500	215JM	9-5/8	8-1/8	5-1/4	4-1/4	7	13/32	13-1/8	25-3/8	12-7/16	253
15	3500	215JM	9-1/2	8	5-1/4	4-1/4	7	13/32	13-1/8	25-1/4	12-7/16	277

MATERIAL SPECIFICATIONS

PART NAME	NICKEL ALUMINUM BRONZE	STAINLESS STEEL
Casing, Cover & Impeller	AMPCO® 483	316 Stainless
Wear Ring	AMPCO® 18	316 Stainless
Motor Shaft	Steel	Steel
Shaft Sleeve	AMPCO® 18	316 Stainless
Adapter	Cast Iron	Cast Iron

* Also available in Duplex 2205

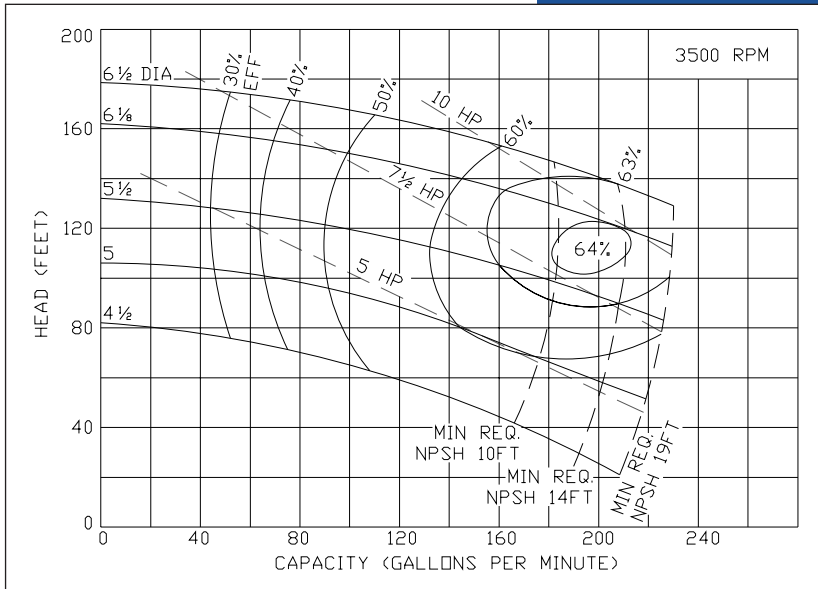

Ampco Centrifugal Pumps

MODEL ZC2 2 1/2 X 2

Curves show approximate characteristics based on clear 68° water. Rated point is guaranteed.

Heavy-duty Z Series pumps have maximum wall thickness and 150 lb. flat faced flanged connections.

Seal options include Type 21, Type 1 and Type 9 with choice of sealing materials.

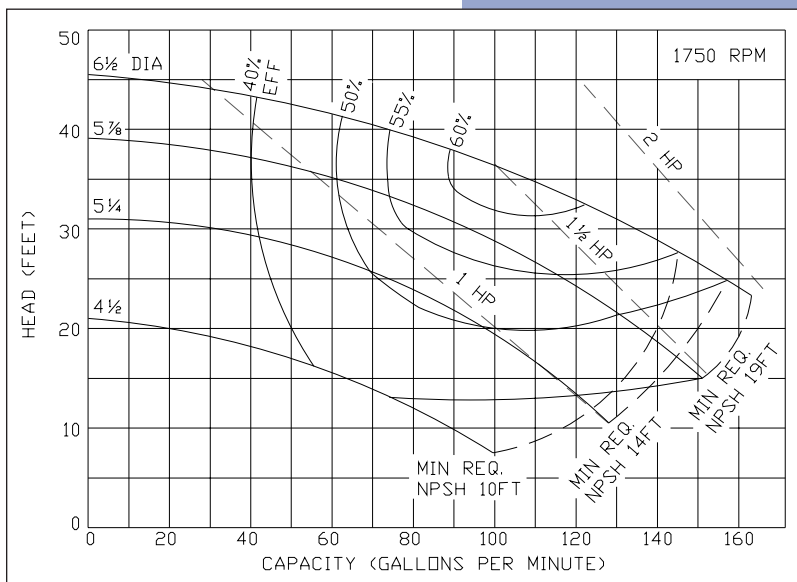
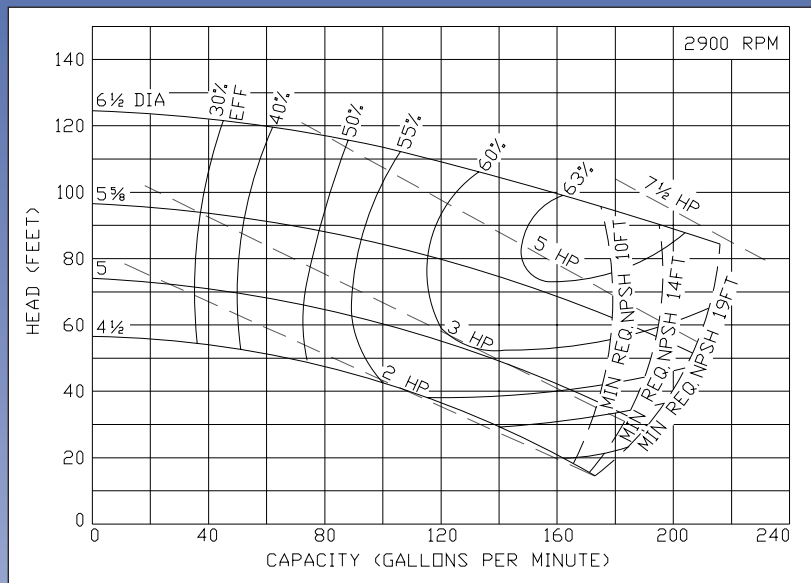

Ampco Pumps Company

4424 West Mitchell Street
 Milwaukee, Wisconsin 53214
 PHONE (414) 643-1852
 FAX (414) 643-4452

Ampco Centrifugal Pumps

DATA SHEET

MODEL ZC2/ZCH2 3X2

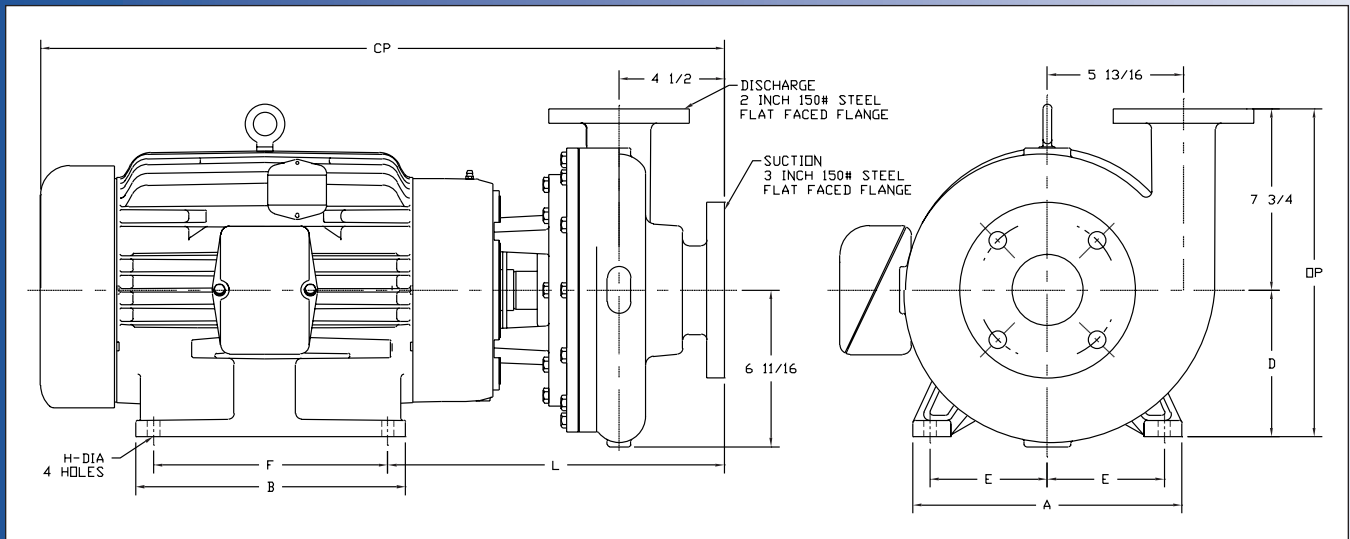
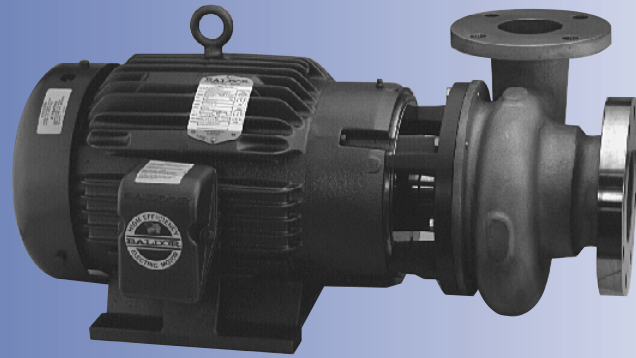

TEFC MOTOR			DIMENSIONS IN INCHES (For Reference Only)									APPROX. WEIGHT (LBS)
HP	RPM	FRAME	A (typ)	B (typ)	D	E	F	H	L	CP	OP	
3	1750	182JM	8-5/8	6-1/2	4-1/2	3-3/4	4-1/2	13/32	12-1/8	21-1/4	12-1/4	179
5	1750	184JM	8-5/8	6-1/2	4-1/2	3-3/4	5-1/2	13/32	12-1/8	22-3/4	12-1/4	203
7-1/2	1750	213JM	9-1/2	8	5-1/4	4-1/2	5-1/2	13/32	13-1/8	24-1/4	13	254
10	1750	215JM	9-1/2	8	5-1/4	4-1/4	7	13/32	13-1/8	25-3/8	13	266
20	3500	256JM	11-1/2	11-1/2	6-1/4	5	10	17/32	14-3/8	29-1/4	14	433
25	3500	284JM	12-3/4	12-3/4	7	5-1/2	9-1/2	17/32	14-3/8	32-7/8	14-3/4	599
30	3500	286JM	12-3/4	12-3/4	7	5-1/2	11	17/32	14-3/8	33-7/16	14-3/4	660
40	3500	324JM	14	12	8	6-1/4	10-1/2	21/32	14-7/8	34-3/4	15-3/4	755
50	3500	326JM	14-1/2	14	8	6-1/4	12	21/32	14-7/8	34-3/4	15-3/4	773

MATERIAL SPECIFICATIONS

PART NAME	NICKEL ALUMINUM BRONZE	STAINLESS STEEL
Casing, Cover & Impeller	AMPCO® 483	316 Stainless
Wear Rings	AMPCO® 18	316 Stainless
Motor Shaft	Steel	Steel
Shaft Sleeve	AMPCO® 18	316 Stainless
Adapter	Cast Iron	Cast Iron

* Also available in Duplex 2205

Ampco Centrifugal Pumps

MODEL ZC2/ZCH2 3X2

Curves show approximate characteristics based on clear 68° water. Rated point is guaranteed.

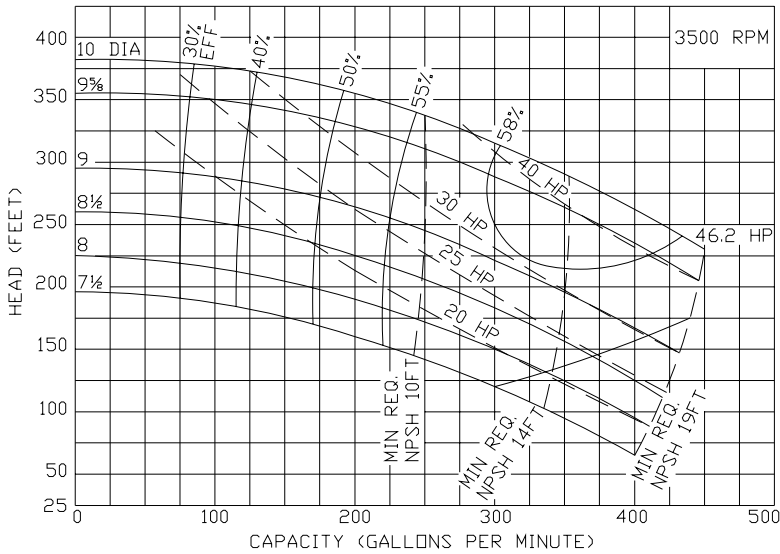

Heavy-duty Z Series pumps have maximum wall thickness and 150 lb. flat faced flanged connections.

Seal options include Type 21, Type 1 and Type 9 with choice of sealing materials.

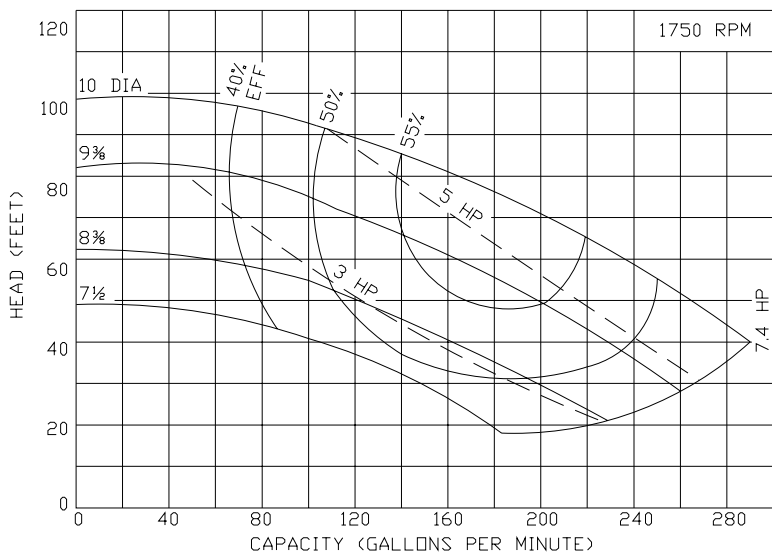
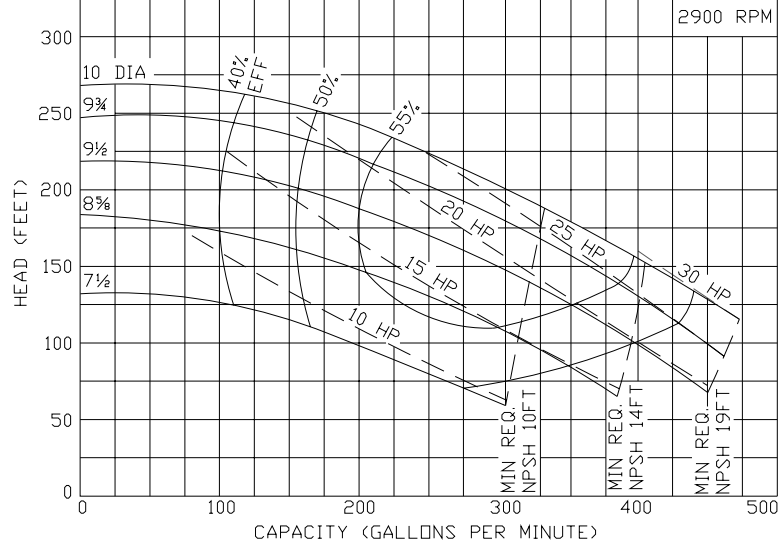

Ampco Pumps Company

4424 West Mitchell Street
 Milwaukee, Wisconsin 53214
 PHONE (414) 643-1852
 FAX (414) 643-4452

Ampco Centrifugal Pumps

DATA SHEET

MODEL ZC2/ZCH2 3X2 1/2

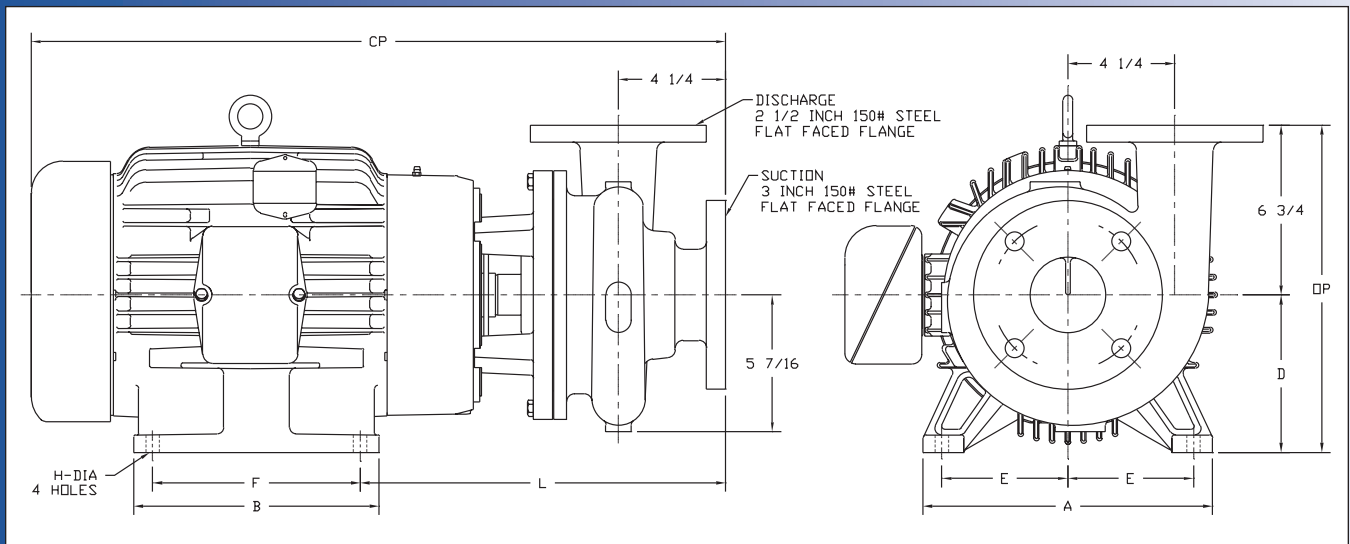
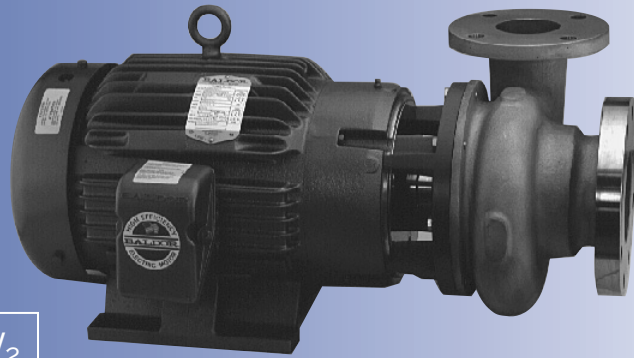

	TEFC MOTOR			DIMENSIONS IN INCHES (For Reference Only)									APPROX. WEIGHT (LBS)
	HP	RPM	FRAME	A (max)	B (max)	D	E	F	H	L	CP	OP	
ZC2	1	1750	143JM	6-1/2	6	3-1/2	2-3/4	4	11/32	11-5/8	19-15/16	10-1/4	129
ZC2	1-1/2	1750	145JM	6-1/2	6	3-1/2	2-3/4	5	11/32	11-5/8	19-15/16	10-1/4	133
ZC2	2	1750	145JM	6-1/2	6	3-1/2	2-3/4	5	11/32	11-5/8	19-15/16	10-1/4	139
ZC2	3	1750	182JM	8-5/8	6-1/2	4-1/2	3-3/4	4-1/2	13/32	12-1/4	21-5/16	11-1/4	165
ZC2	5	3500	184JM	8-5/8	6-1/2	4-1/2	3-3/4	5-1/2	13/32	12-1/4	22-11/16	11-1/4	178
ZC2	7-1/2	3500	213JM	9-5/8	8-1/8	5-1/4	4-1/4	5-1/2	13/32	13-1/4	25-9/16	12	246
ZC2	10	3500	215JM	9-5/8	8-1/8	5-1/4	4-1/4	7	13/32	13-1/4	25-9/16	12	264
ZCH2	15	3500	254JM	11-1/2	9-3/4	6-1/4	5	8-1/4	17/32	14-1/2	27-9/16	13	361
ZCH2	20	3500	256JM	11-1/2	11-1/2	6-1/4	5	10	17/32	14-1/2	29-3/8	13	399
ZCH2	25	3500	284JM	12-3/4	12-3/4	7	5-1/2	9-1/2	9/16	14-1/2	32-15/16	13-3/4	529

MATERIAL SPECIFICATIONS

PART NAME	NICKEL ALUMINUM BRONZE	STAINLESS STEEL
Casing, Cover & Impeller	AMPCO® 483	316 Stainless
Wear Ring	AMPCO® 18	316 Stainless
Motor Shaft	Steel	Steel
Shaft Sleeve	AMPCO® 18	316 Stainless
Adapter	Cast Iron	Cast Iron

* Also available in Duplex 2205

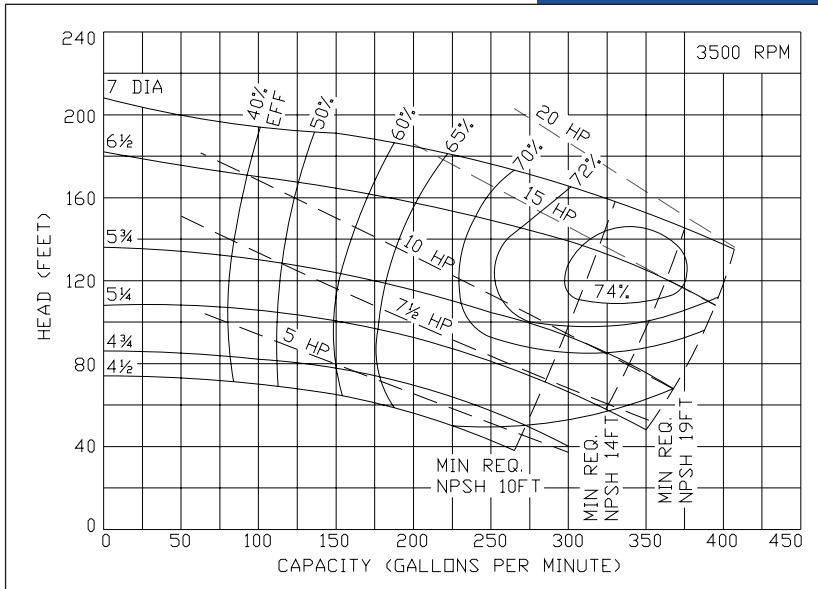

Ampco Centrifugal Pumps

MODEL ZC2/ZCH2 3X2¹/₂

Curves show approximate characteristics based on clear 68° water. Rated point is guaranteed.

Heavy-duty Z Series pumps have maximum wall thickness and 150 lb. flat faced flanged connections.

Seal options include Type 21, Type 1 and Type 9 with choice of sealing materials.

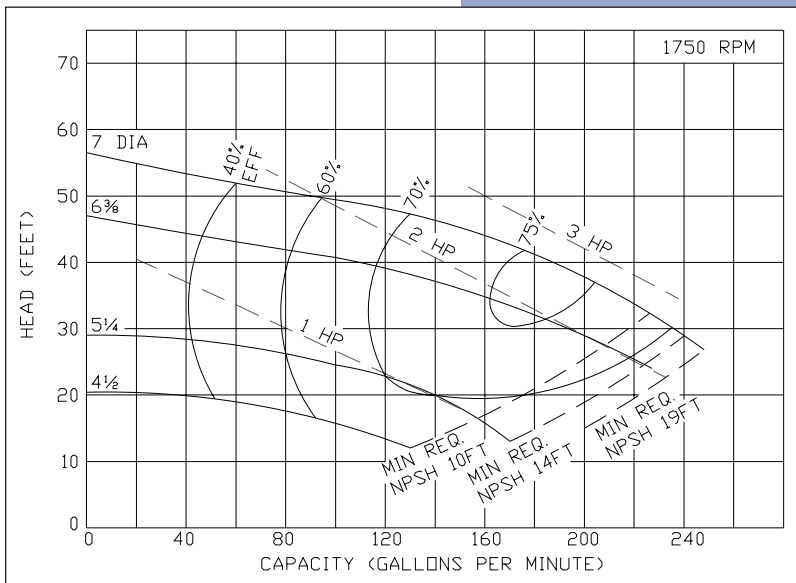
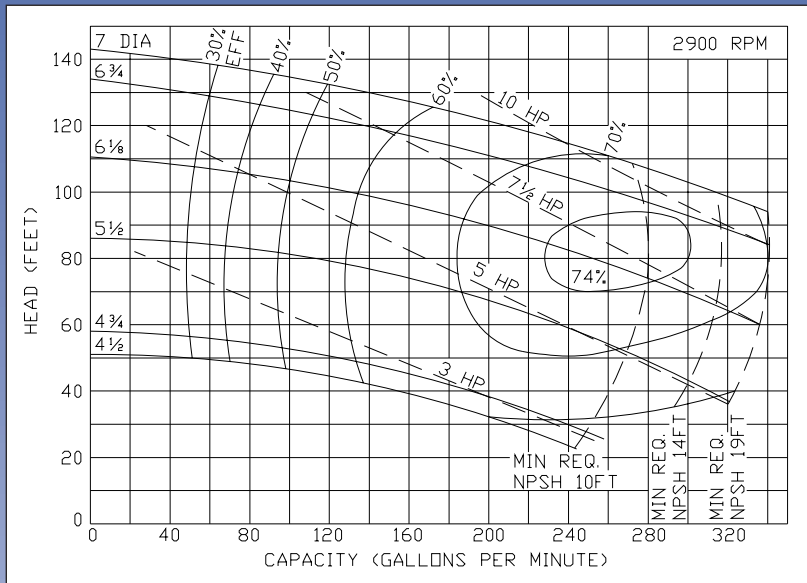

Ampco Pumps Company

4424 West Mitchell Street
 Milwaukee, Wisconsin 53214
 PHONE (414) 643-1852
 FAX (414) 643-4452

Ampco Centrifugal Pumps

DATA SHEET

MODEL ZC2/ZCH2 4X3

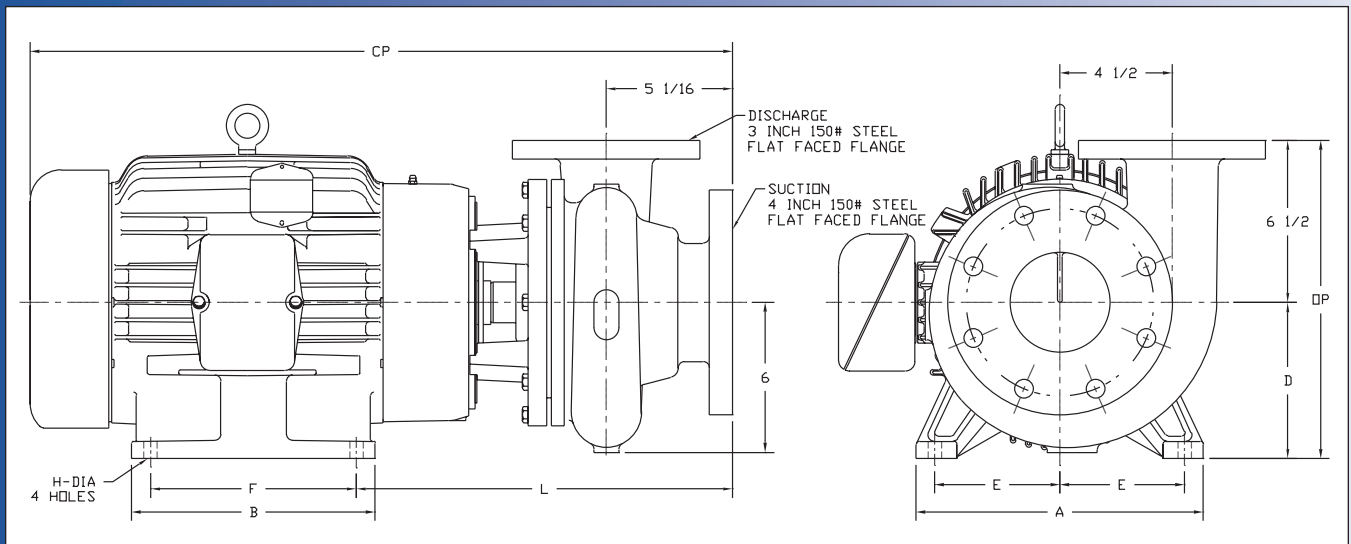
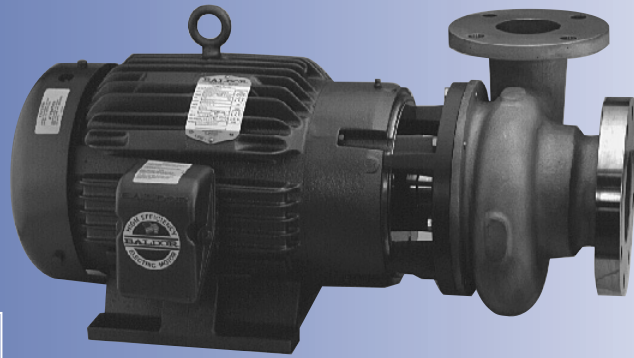

	TEFC MOTOR			DIMENSIONS IN INCHES (For Reference Only)									APPROX. WEIGHT (LBS)
	HP	RPM	FRAME	A (max)	B (max)	D	E	F	H	L	CP	OP	
ZC2	1-1/2	1750	145JM	6-1/2	6	3-1/2	2-3/4	5	11/32	12-3/16	20-1/2	10	152
ZC2	2	1750	145JM	6-1/2	6	3-1/2	2-3/4	5	11/32	12-3/16	20-1/2	10	158
ZC2	3	1750	182JM	8-5/8	6-1/2	4-1/2	3-3/4	4-1/2	13/32	12-13/16	21-7/8	11	184
ZC2	5	1750	184JM	8-5/8	6-1/2	4-1/2	3-3/4	5-1/2	13/32	12-13/16	23-7/16	11	197
ZC2	10	3500	215JM	9-5/8	8-1/8	5-1/4	4-1/4	7	13/32	13-9/16	26-1/8	11-3/4	283
ZCH2	15	3500	254JM	11-1/2	9-3/4	6-1/4	5	8-1/4	17/32	15-1/16	28-1/8	12-3/4	391
ZCH2	20	3500	256JM	11-1/2	11-1/2	6-1/4	5	10	17/32	15-1/16	29-15/16	12-3/4	429
ZCH2	25	3500	284JM	12-3/4	12-3/4	7	5-1/2	9-1/2	9/16	15-1/16	33-1/2	13-1/2	559
ZCH2	30	3500	286JM	12-3/4	12-3/4	7	5-1/2	11	9/16	15-1/16	34-1/8	13-1/2	688

MATERIAL SPECIFICATIONS

PART NAME	NICKEL ALUMINUM BRONZE	STAINLESS STEEL
Casing, Cover & Impeller	AMPCO® 483	316 Stainless
Wear Ring	AMPCO® 18	316 Stainless
Motor Shaft	Steel	Steel
Shaft Sleeve	AMPCO® 18	316 Stainless
Adapter	Cast Iron	Cast Iron

* Also available in Duplex 2205

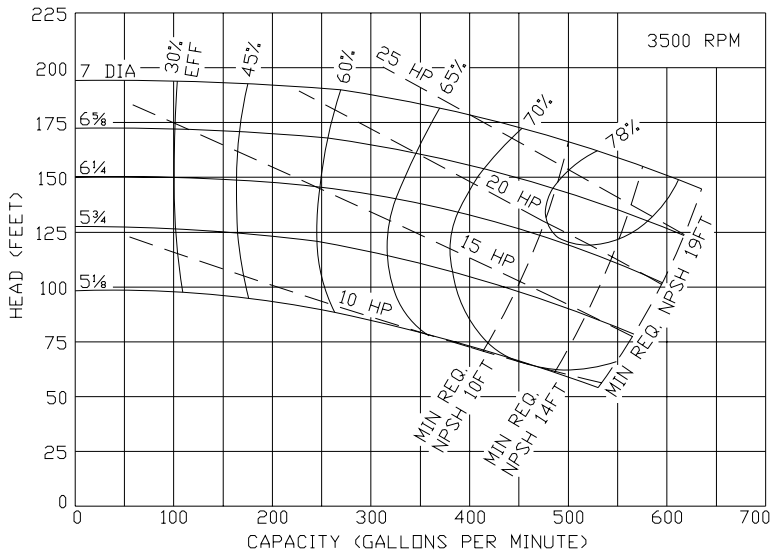

Ampco Centrifugal Pumps

MODEL ZC2/ZCH2 4X3

Curves show approximate characteristics based on clear 68° water. Rated point is guaranteed.

Heavy-duty Z Series pumps have maximum wall thickness and 150 lb. flat faced flanged connections.

Seal options include Type 21, Type 1 and Type 9 with choice of sealing materials.

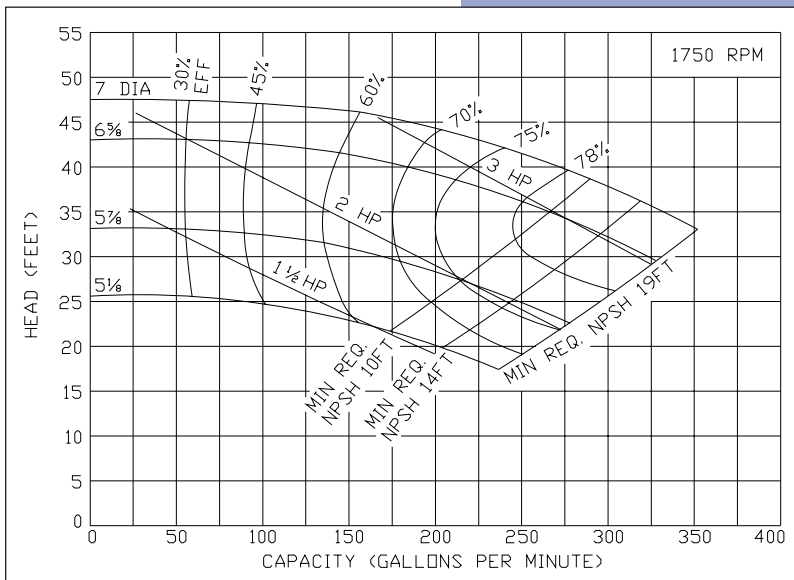
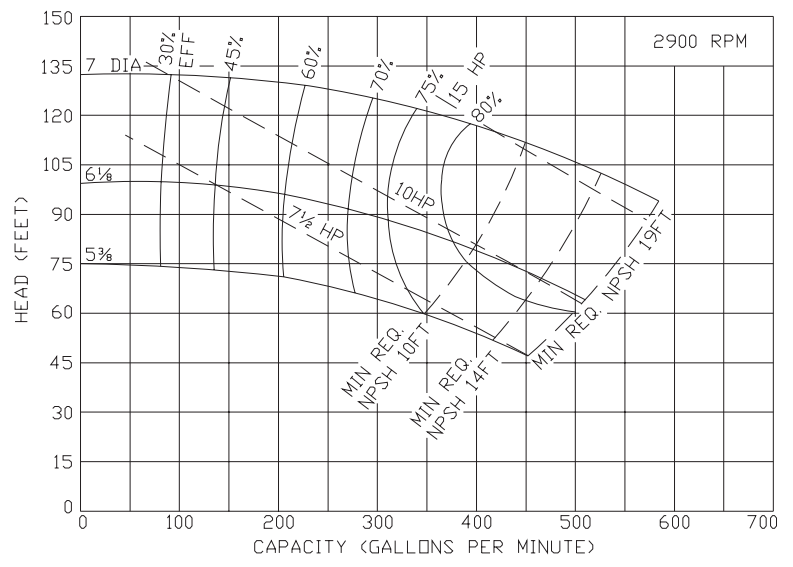

Ampco Pumps Company

4424 West Mitchell Street
 Milwaukee, Wisconsin 53214
 PHONE (414) 643-1852
 FAX (414) 643-4452

Ampco Centrifugal Pumps

DATA SHEET

MODEL ZC2/ZCH2 4X3C

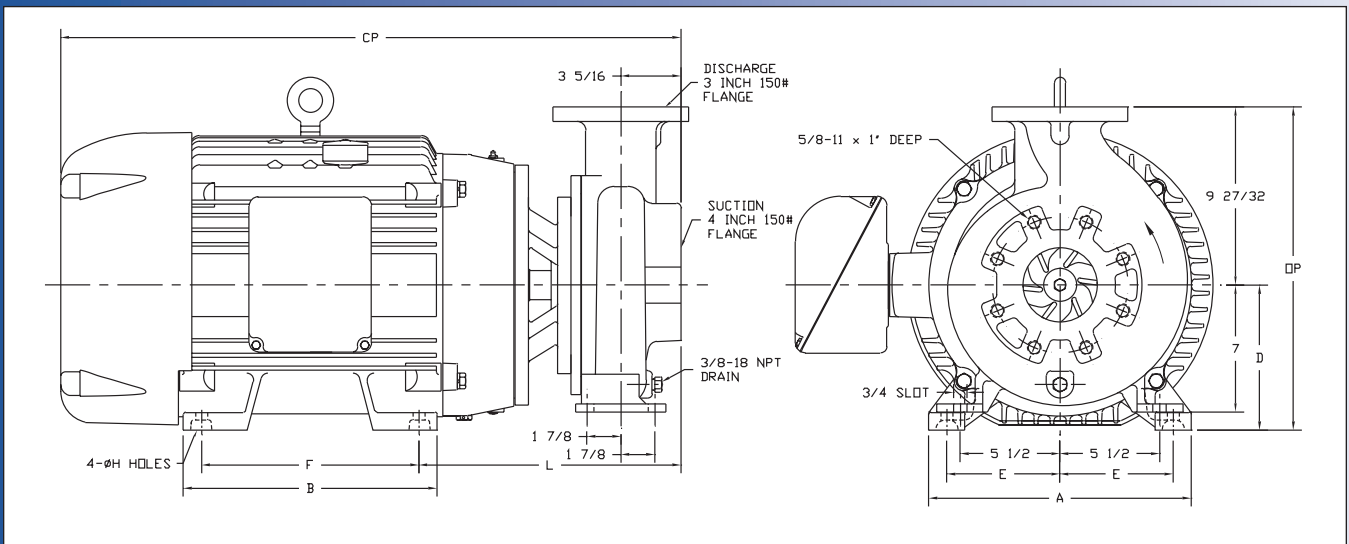

	TEFC MOTOR			DIMENSIONS IN INCHES (For Reference Only)									APPROX. WEIGHT (LBS)
	HP	RPM	FRAME	A (max)	B (max)	D	E	F	H	L	CP	OP	
ZC2	3	1750	182JM	8-5/8	6-1/2	4-1/2	3-3/4	4-1/2	13/32	11-15/32	20-17/32	14-11/32	204
ZC2	5	1750	184JM	8-5/8	6-1/2	4-1/2	3-3/4	5-1/2	13/32	11-15/32	22-1/16	14-11/32	228
ZC2	7-1/2	1750	213JM	9-1/2	8	5-1/4	4-1/4	5-1/2	13/32	12-15/32	23-17/32	15-3/32	279
ZC2	10	1750	215JM	9-1/2	8	5-1/4	4-1/4	7	13/32	12-15/32	24-21/32	15-3/32	293
ZC2	15	1750	254JM	11-1/2	9-3/4	6-1/4	5	8-1/4	17/32	13-23/32	26-13/16	16-3/32	456
ZCH2	30	3500	286JM	12-3/4	12-3/4	7	5-1/2	11	9/16	13-31/32	32-25/32	16-27/32	685
ZCH2	40	3500	324JM	14-1/2	14	8	6-1/4	10-1/2	21/32	14-15/32	34-1/4	17-27/32	780
ZCH2	50	3500	326JM	14-1/2	14	8	6-1/4	12	21/32	14-15/32	34-1/4	17-27/32	789

MATERIAL SPECIFICATIONS

PART NAME	NICKEL ALUMINUM BRONZE	STAINLESS STEEL
Casing, Cover & Impeller	AMPCO® 483	316 Stainless
Wear Ring	AMPCO® 18	316 Stainless
Motor Shaft	Steel	Steel
Shaft Sleeve	AMPCO® 18	316 Stainless
Adapter	Cast Iron	Cast Iron

* Also available in Duplex 2205

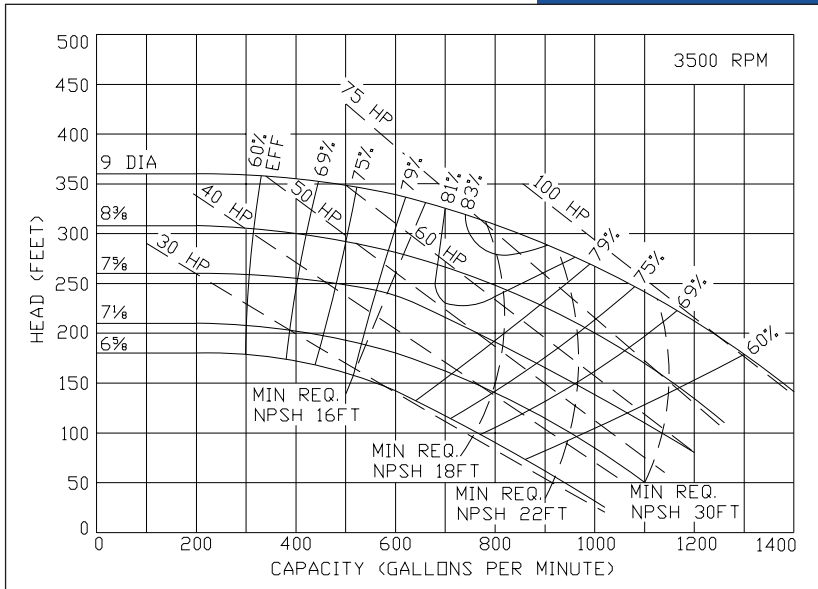

Ampco Centrifugal Pumps

MODEL ZC2/ZCH2 4X3C

Curves show approximate characteristics based on clear 68° water. Rated point is guaranteed.

Heavy-duty Z Series pumps have maximum wall thickness and 150 lb. flat faced flanged connections. Seal options include Type 21, Type 1 and Type 9 with choice of sealing materials.

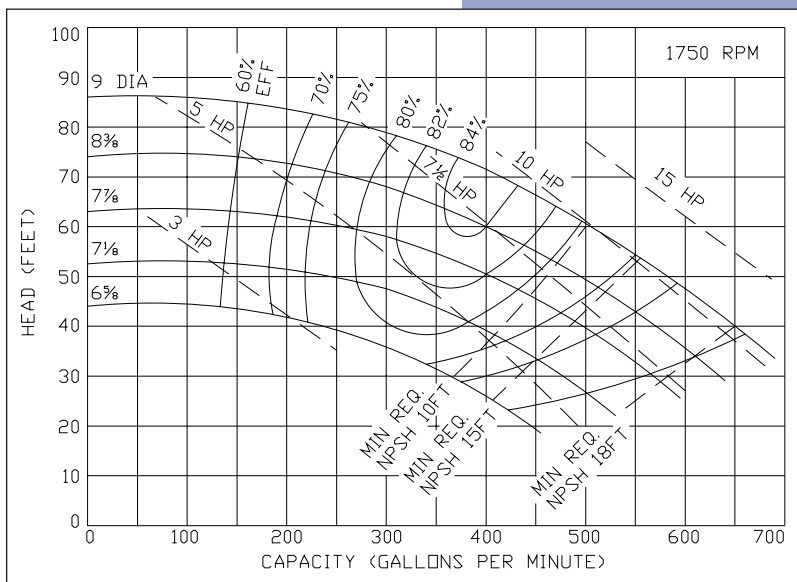
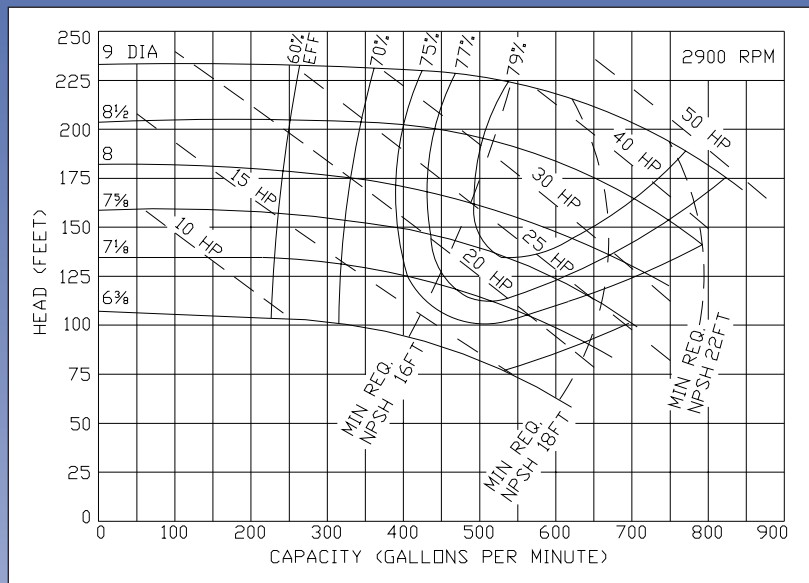

Ampco Pumps Company

4424 West Mitchell Street
 Milwaukee, Wisconsin 53214
 PHONE (414) 643-1852
 FAX (414) 643-4452

Ampco Centrifugal Pumps

DATA SHEET

MODEL ZC2/ZCH2 4X3L

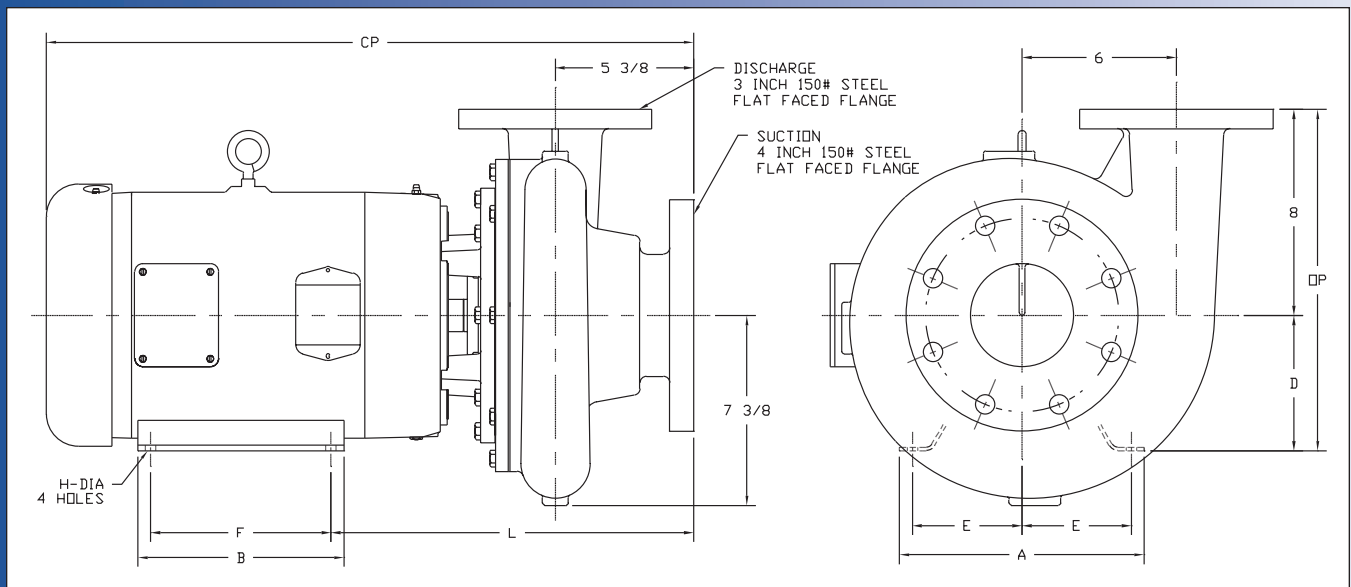
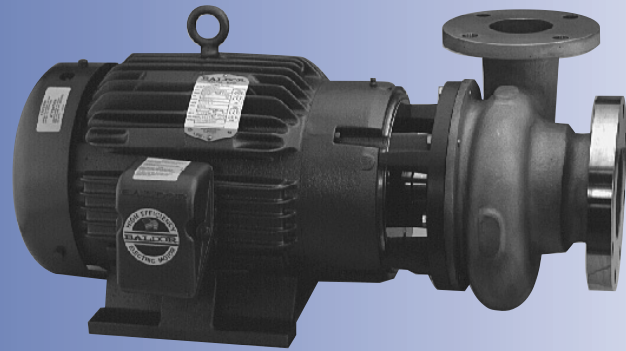

TEFC MOTOR			DIMENSIONS IN INCHES (For Reference Only)									APPROX. WEIGHT (LBS)
HP	RPM	FRAME	A (typ)	B (typ)	D	E	F	H	L	CP	OP	
7-1/2	1750	213JM	9-1/2	8	5-1/4	4-1/4	5-1/2	13/32	14-1/8	25-1/8	13-1/4	296
10	1750	215JM	9-1/2	8	5-1/4	4-1/4	7	13/32	14-1/8	26-5/16	13-1/4	314
15	1750	254JM	11-1/2	9-3/4	6-1/4	5	8-1/4	17/32	15-3/8	28-7/16	14-1/4	477
20	1750	256JM	11-1/2	11-1/2	6-1/4	5	10	17/32	15-3/8	30-1/2	14-1/4	525

MATERIAL SPECIFICATIONS

PART NAME	NICKEL ALUMINUM BRONZE	STAINLESS STEEL
Casing, Cover & Impeller	AMPCO® 483	316 Stainless
Wear Rings	AMPCO® 18	316 Stainless
Motor Shaft	Steel	Steel
Shaft Sleeve	AMPCO® 18	316 Stainless
Adapter	Cast Iron	Cast Iron

* Also available in Duplex 2205

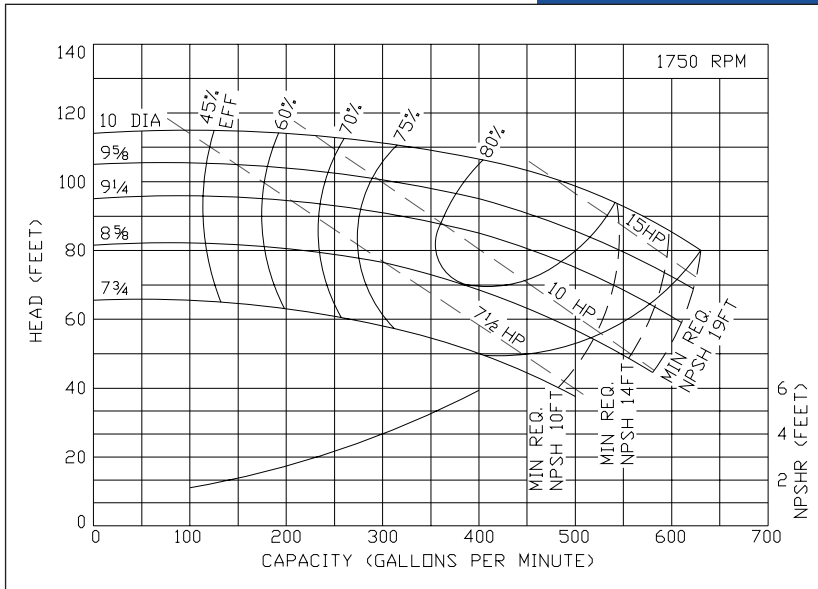

Ampco Centrifugal Pumps

MODEL ZC2/ZCH2 4x3L

Curves show approximate characteristics based on clear 68° water. Rated point is guaranteed.

Heavy-duty Z Series pumps have maximum wall thickness and 150 lb. flat faced flanged connections.

Seal options include Type 21, Type 1 and Type 9 with choice of sealing materials.

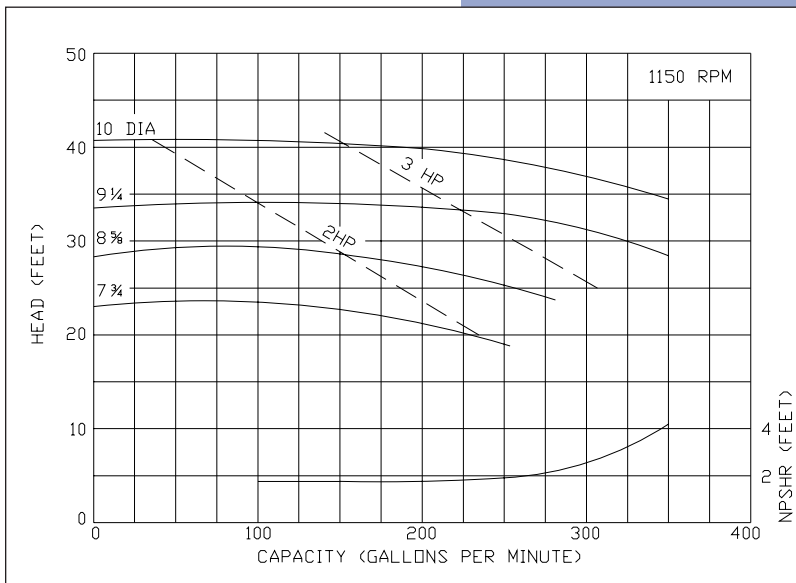
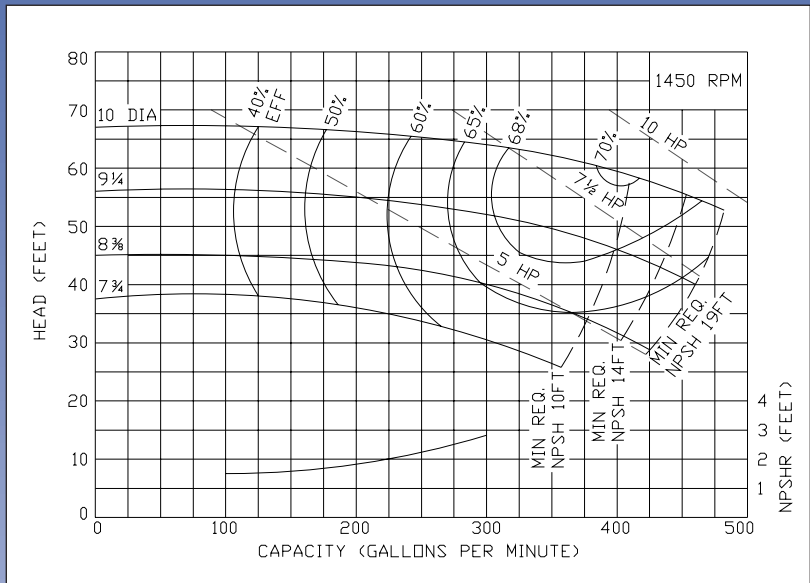

Ampco Pumps Company

4424 West Mitchell Street
 Milwaukee, Wisconsin 53214
 PHONE (414) 643-1852
 FAX (414) 643-4452

Ampco Centrifugal Pumps

DATA SHEET

MODEL ZC2/ZCH2 5x4

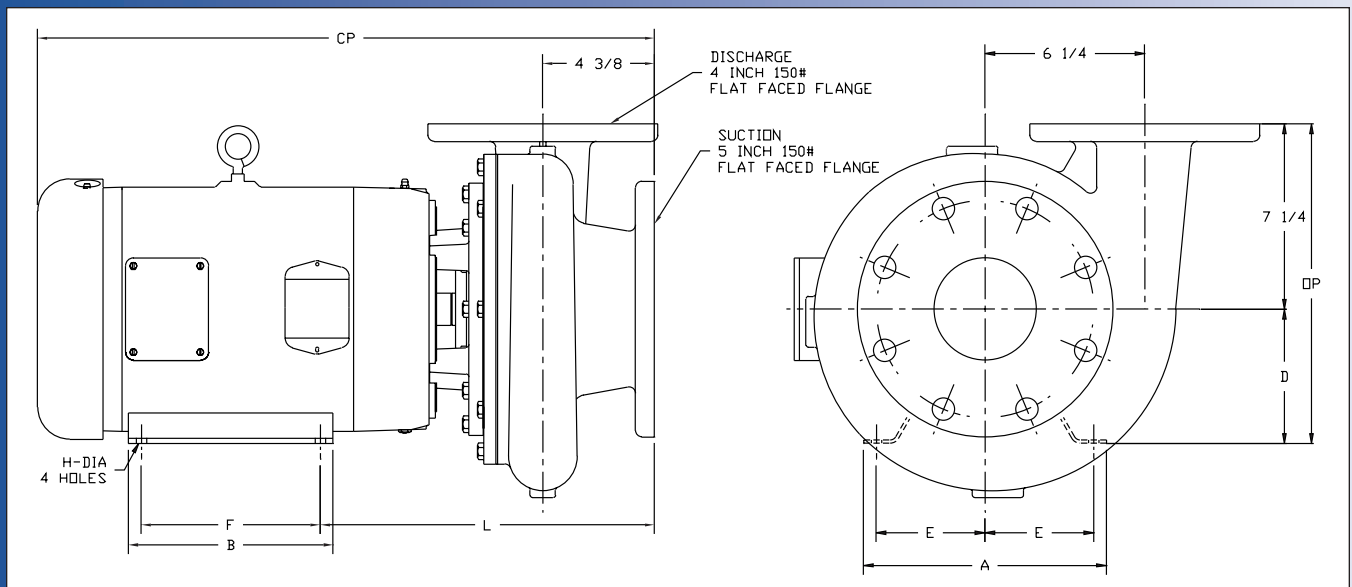
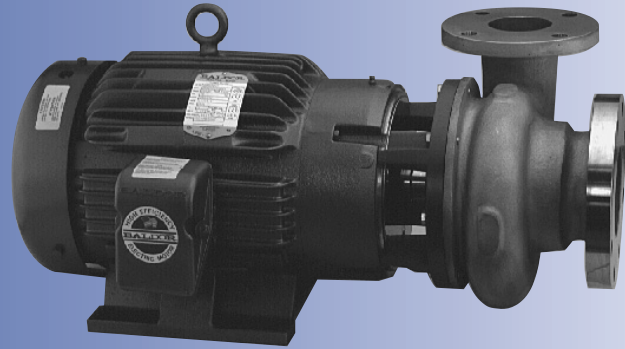

TEFC MOTOR			DIMENSIONS IN INCHES (For Reference Only)									APPROX. WEIGHT (LBS)
HP	RPM	FRAME	A (typ)	B (typ)	D	E	F	H	L	CP	OP	
7-1/2	1750	213JM	9-1/2	8	5-1/4	4-1/4	5-1/2	13/32	13-3/32	24-1/8	12-1/2	296
10	1750	215JM	9-1/2	8	5-1/4	4-1/4	7	13/32	13-3/32	25-5/16	12-1/2	314
15	1750	254JM	11-1/2	9-3/4	6-1/4	5	8-1/4	17/32	14-11/32	27-7/16	13-1/2	477
20	1750	256JM	11-1/2	11-1/2	6-1/4	5	10	17/32	14-11/32	29-1/2	13-1/2	525

MATERIAL SPECIFICATIONS

PART NAME	NICKEL ALUMINUM BRONZE
Casing, Cover & Impeller	AMPCO® 482
Wear Rings	AMPCO® 18
Motor Shaft	Steel
Shaft Sleeve	AMPCO® 18
Adapter	Cast Iron

Ampco Centrifugal Pumps

DATA SHEET

MODEL ZC2/ZCH2 5X4P

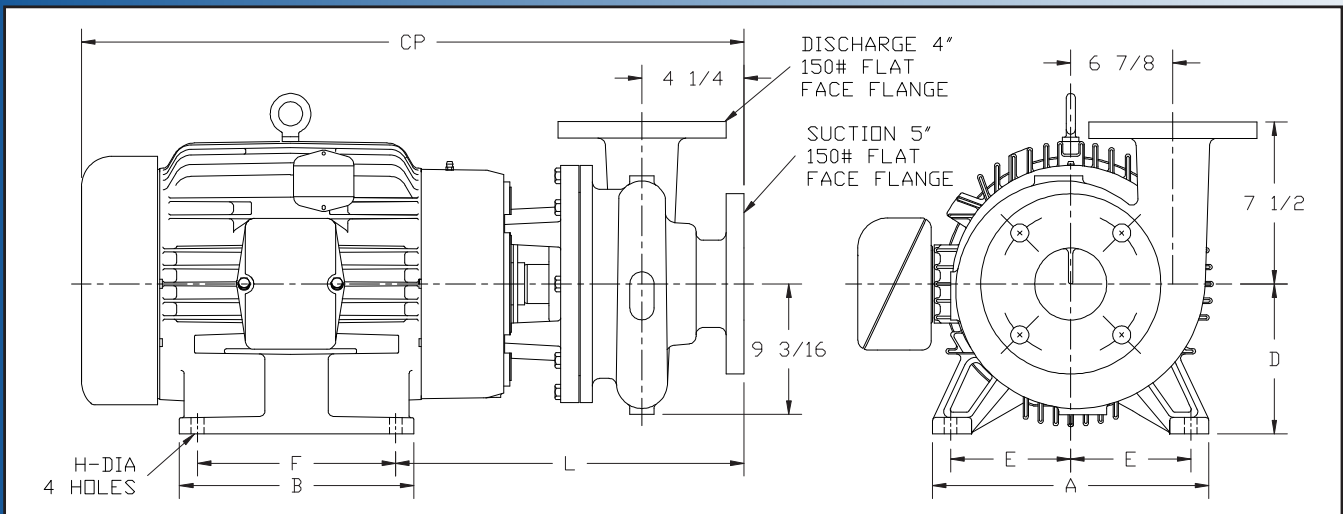
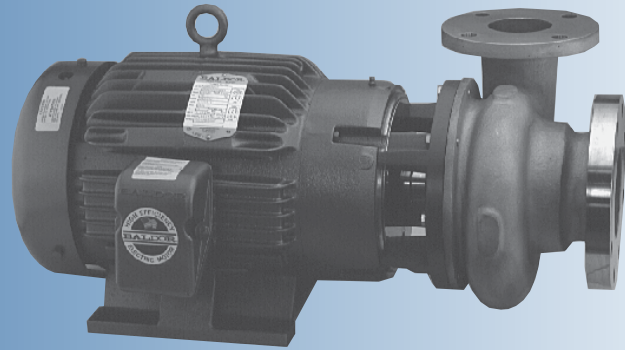

TEFC MOTOR			DIMENSIONS IN INCHES (For Reference Only)									APPROX. WEIGHT (LBS)
HP	RPM	FRAME	A (typ)	B (typ)	D	E	F	H	L	CP	OP	
7-1/2	1750	213JM	9-1/2	8	5-1/4	4-1/4	5-1/2	13/32	14-3/8	25-3/8	12-3/4	397
10	1750	215JM	9-1/2	8	5-1/4	4-1/4	7	13/32	14-3/8	25-3/8	12-3/4	405
15	1750	254JM	11-1/2	9-3/4	6-1/4	5	8-1/4	17/32	14-7/8	28-5/8	13-3/4	556
20	1750	256JM	11-1/2	11-1/2	6-1/4	5	10	17/32	14-7/8	28-5/8	13-3/4	594
30	3500	286JM	12-3/4	12-3/4	7	5-1/2	11	17/32	14-7/8	29-7/16	14-1/2	708
40	3500	324JM	14-1/2	14	8	5-1/2	10-1/2	21/32	15-3/8	29-7/16	15-1/2	855
50	3500	326JM	16	15-1/2	8	6-1/4	12	21/32	15-3/8	29-7/16	15-1/2	1065
60	3500	326JM	16	15-1/2	8	6-1/4	12	21/32	15-3/8	29-7/16	15-1/2	1065
75	3500	364JMZ	17-1/2	14-3/4	9	7	11-1/4	21/32	16	29-7/16	16-1/2	1145
100	3500	365JMZ	17-1/2	15-3/4	9	7	12-1/4	21/32	16	33-7/16	16-1/2	1220
125	3500	365JMZ	17-1/2	15-3/4	9	7	12-1/4	21/32	16	33-7/16	16-1/2	1300

MATERIAL SPECIFICATIONS

PART NAME	NICKEL ALUMINUM BRONZE	STAINLESS STEEL	DUPLEX STAINLESS 2205
Casing, Cover & Impeller	AMPCO® 483	316 Stainless Steel	Duplex Stainless 2205
Wear Rings	AMPCO® 18	316 Stainless Steel	Duplex Stainless 2205
Motor Shaft	Steel	Steel	Steel
Shaft Sleeve	AMPCO® 18	316 Stainless Steel	Duplex Stainless 2205
Adapter	Cast Iron	Cast Iron	Cast Iron

AMPCO PUMPS COMPANY, INC.
Z-SERIES 5 x 4P

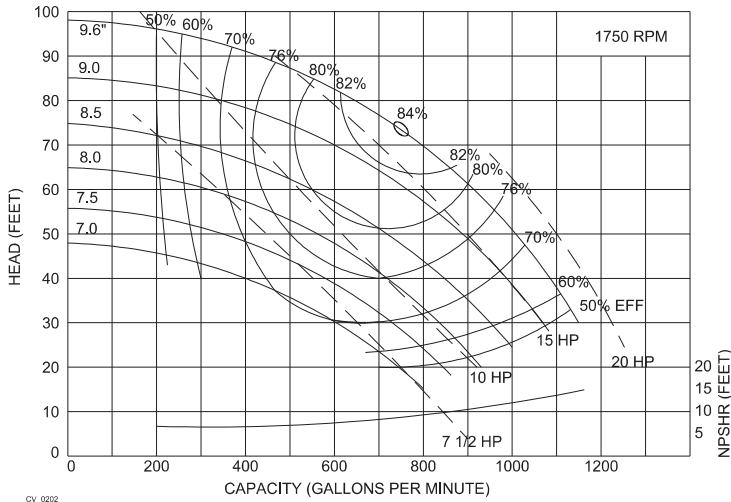

CV_0202

Ampco Centrifugal Pumps

MODEL ZC2/ZCH2 5x4P

Curves show approximate characteristics based on clear 68° water. Rated point is guaranteed.

Heavy-duty Z Series pumps have maximum wall thickness and 150 lb. flat faced flanged connections. Seal options include Type 21, Type 1 and Type 9 with choice of sealing materials.

AMPCO PUMPS COMPANY, INC.
Z-SERIES 5 x 4P

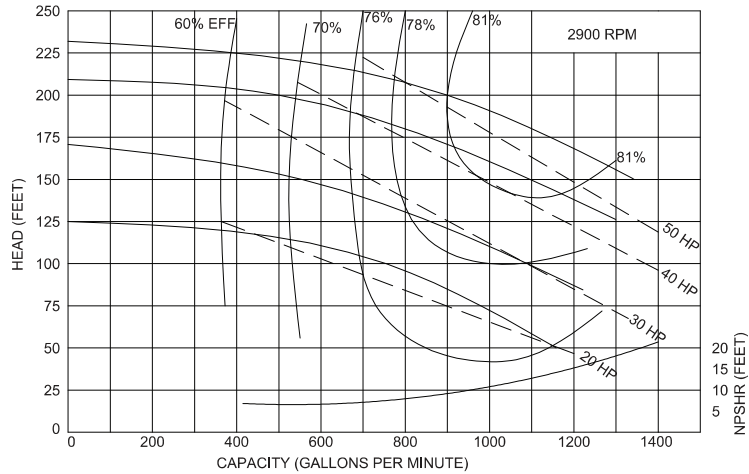

CV_0204

AMPCO PUMPS COMPANY, INC.
Z-SERIES 5 x 4P

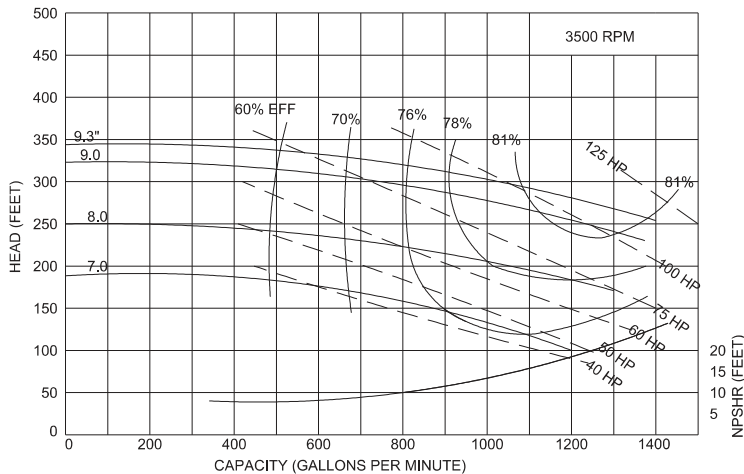

CV_0203

Ampco Pumps Company

2045 W. Mill Road
Glendale, Wisconsin 53209
PHONE (414) 643-1852
FAX (414) 643-4452

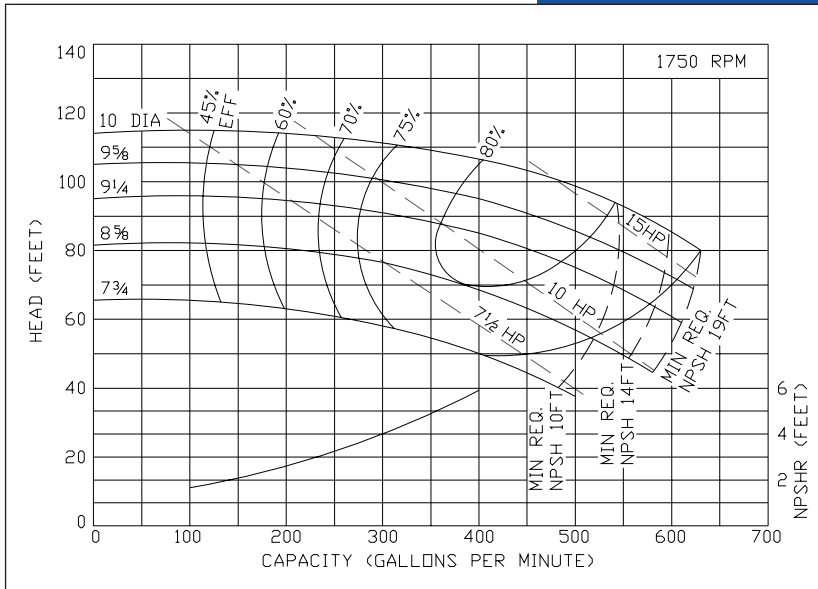

Ampco Centrifugal Pumps

MODEL ZC2/ZCH2 5x4

Curves show approximate characteristics based on clear 68° water. Rated point is guaranteed.

Heavy-duty Z Series pumps have maximum wall thickness and 150 lb. flat faced flanged connections.

Seal options include Type 21, Type 1 and Type 9 with choice of sealing materials.

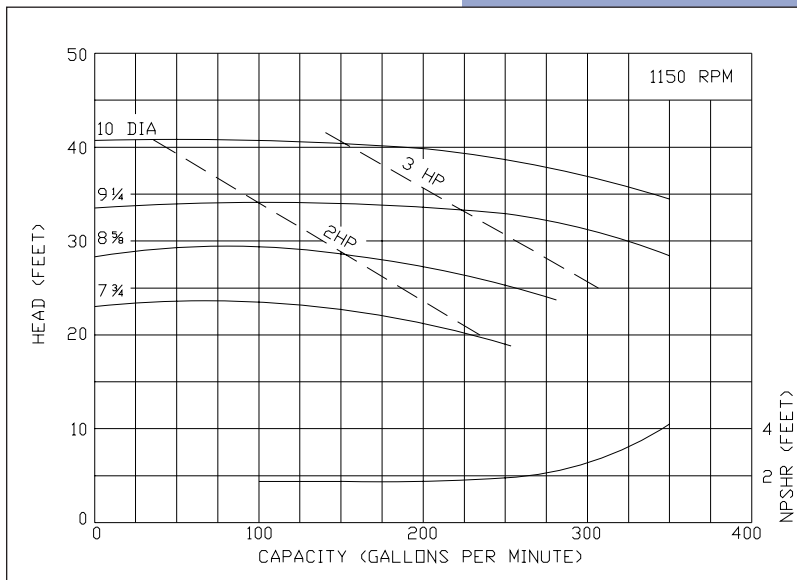
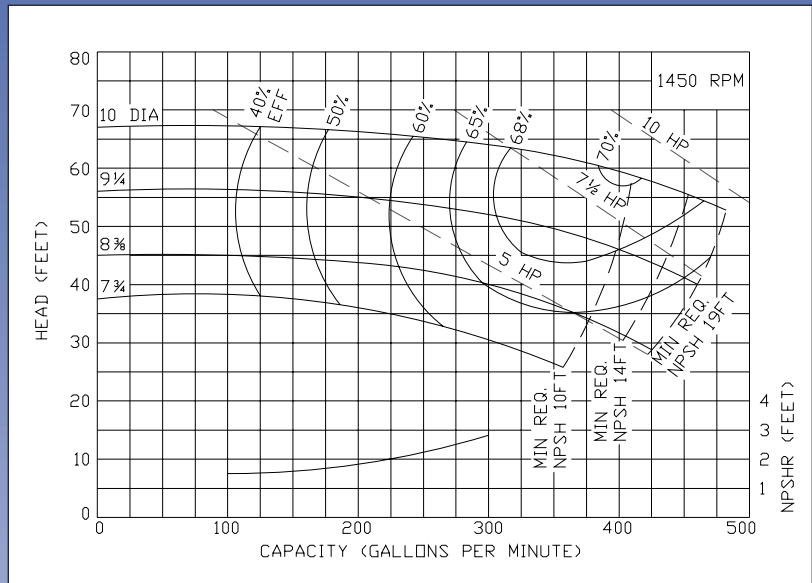

Ampco Pumps Company

4424 West Mitchell Street
 Milwaukee, Wisconsin 53214
 PHONE (414) 643-1852
 FAX (414) 643-4452

Ampco Centrifugal Pumps

DATA SHEET

MODEL ZCH2 6X6

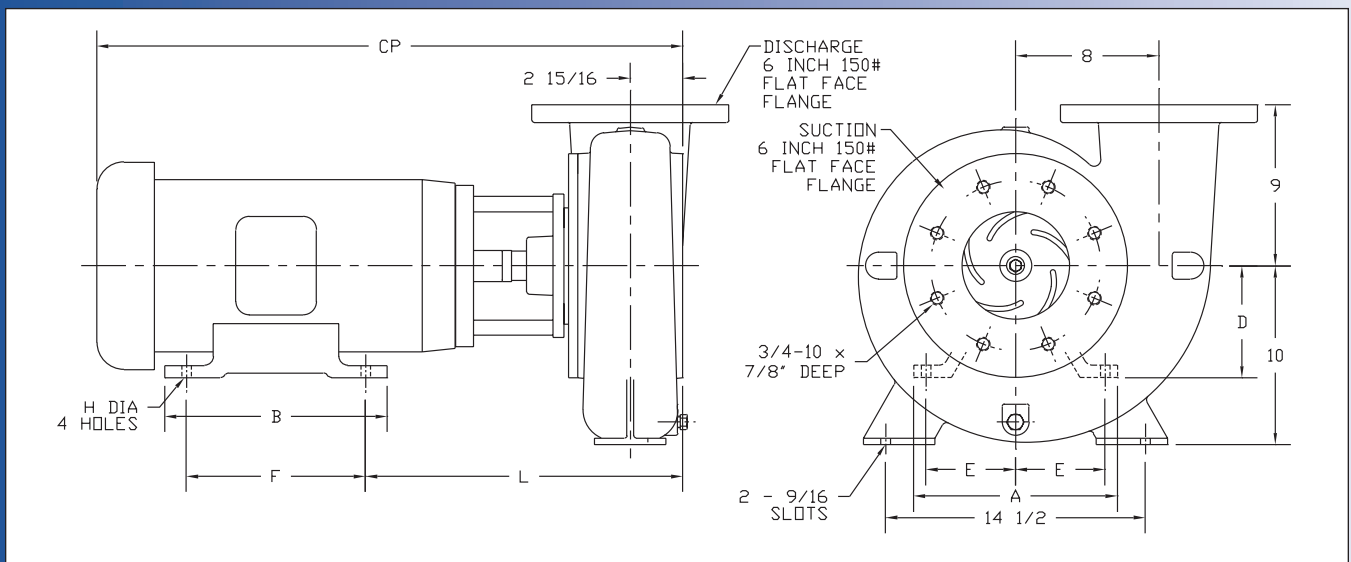
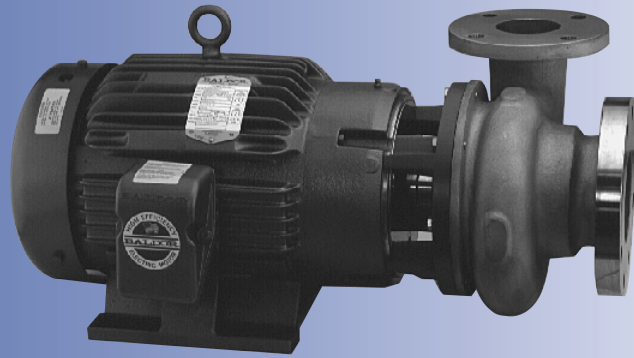

TEFC MOTOR			DIMENSIONS IN INCHES (For Reference Only)								APPROX. WEIGHT (LBS)
HP	RPM	FRAME	A (typ)	B (typ)	D	E	F	H	L	CP	
10	1750	215JP	9-1/2	8	5-1/4	4-1/4	7	13/32	17	28-1/16	439
15	1750	254JP	11-1/2	9-3/4	6-1/4	5	8-1/4	17/32	17-1/4	30-5/16	537
20	1750	256JP	11-1/2	11-1/2	6-1/4	5	10	17/32	17-1/4	32-3/16	570
25	1750	284JP	12-3/4	12-3/4	7	5-1/2	9-1/2	17/32	17-1/4	35-11/16	764
30	1750	286JP	12-3/4	12-3/4	7	5-1/2	11	17/32	17-1/4	36-5/16	774

MATERIAL SPECIFICATIONS

PART NAME	NICKEL ALUMINUM BRONZE	STAINLESS STEEL
Casing, Cover & Impeller	AMPCO® 483	316 Stainless
Wear Ring	AMPCO® 18	316 Stainless
Motor Shaft	Steel	Steel
Shaft Sleeve	AMPCO® 18	316 Stainless
Adapter	Cast Iron	Cast Iron

* Also available in Duplex 2205

Ampco Centrifugal Pumps

MODEL ZCH2 6X6

Curves show approximate characteristics based on clear 68° water. Rated point is guaranteed.

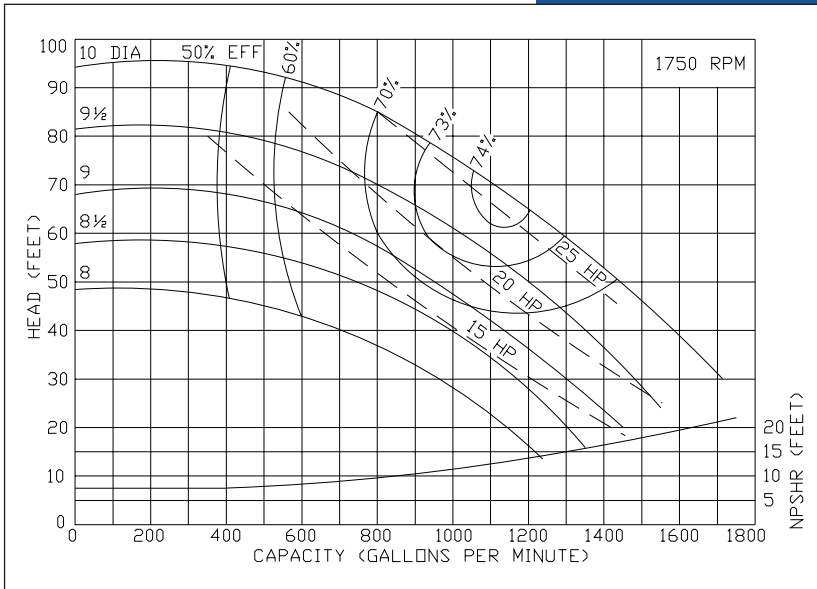

Heavy-duty Z Series pumps have maximum wall thickness and 150 lb. flat faced flanged connections.

Seal options include Type 21, Type 1 and Type 9 with choice of sealing materials.

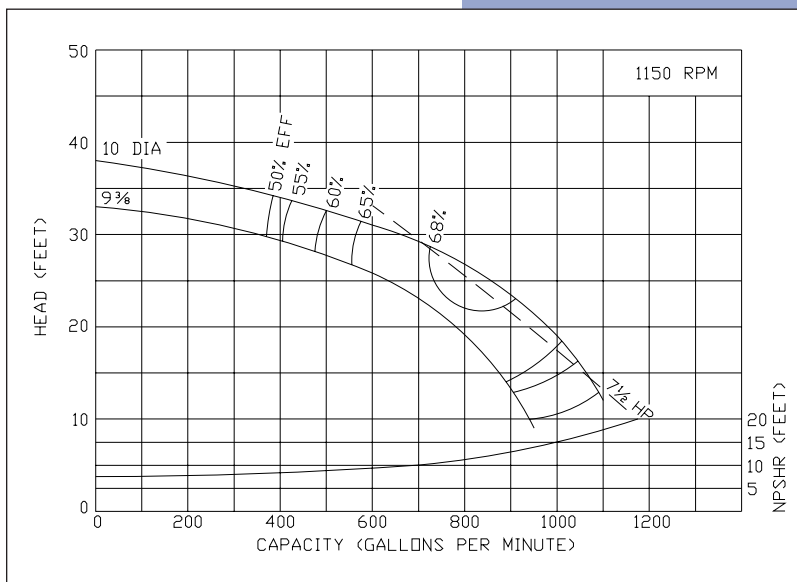
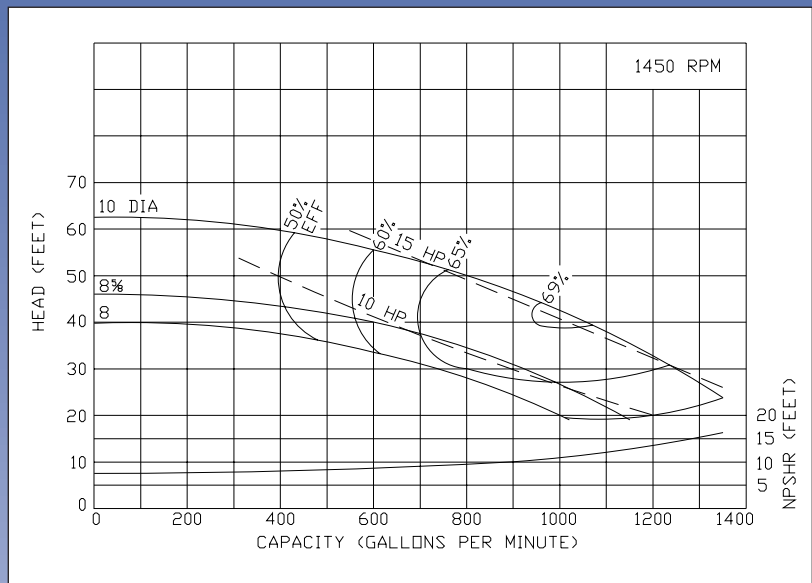

Ampco Pumps Company

4424 West Mitchell Street
 Milwaukee, Wisconsin 53214
 PHONE (414) 643-1852
 FAX (414) 643-4452

Ampco Centrifugal Pumps

DATA SHEET

MODEL ZCH2 8 x 6

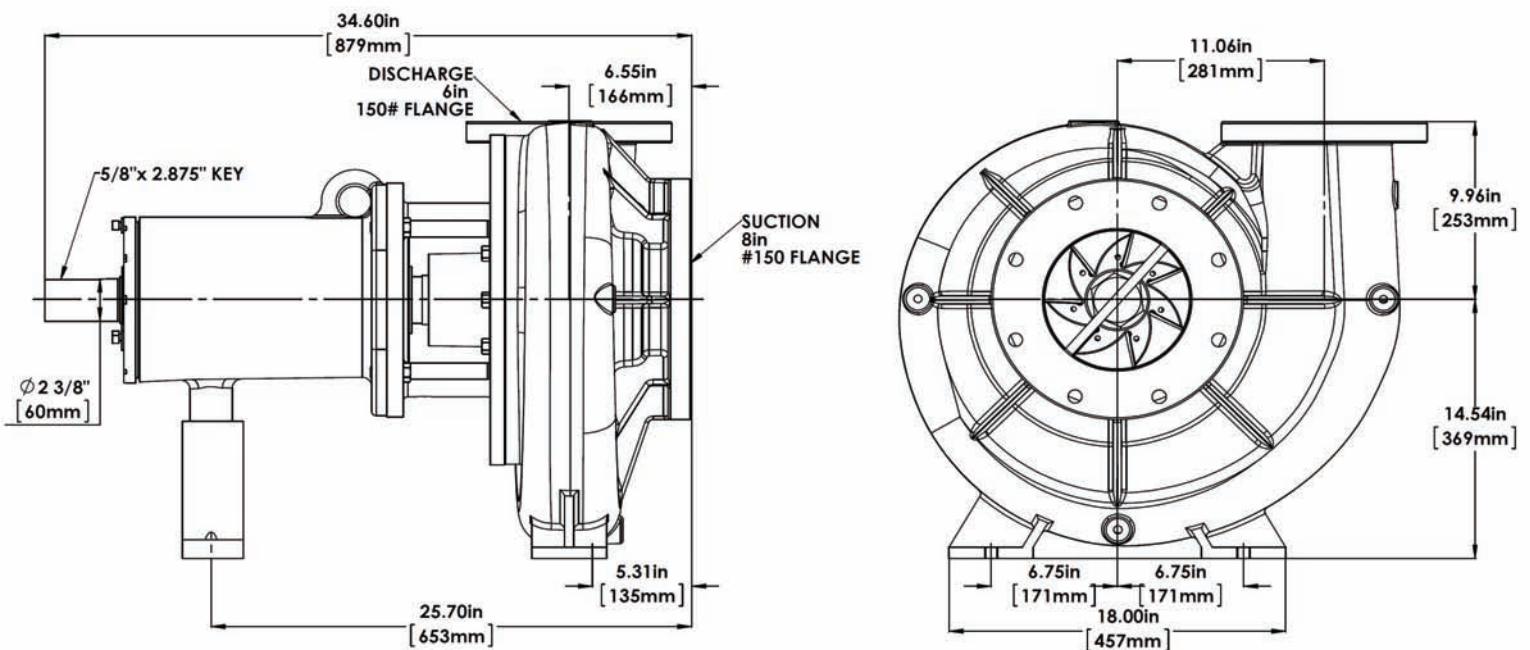
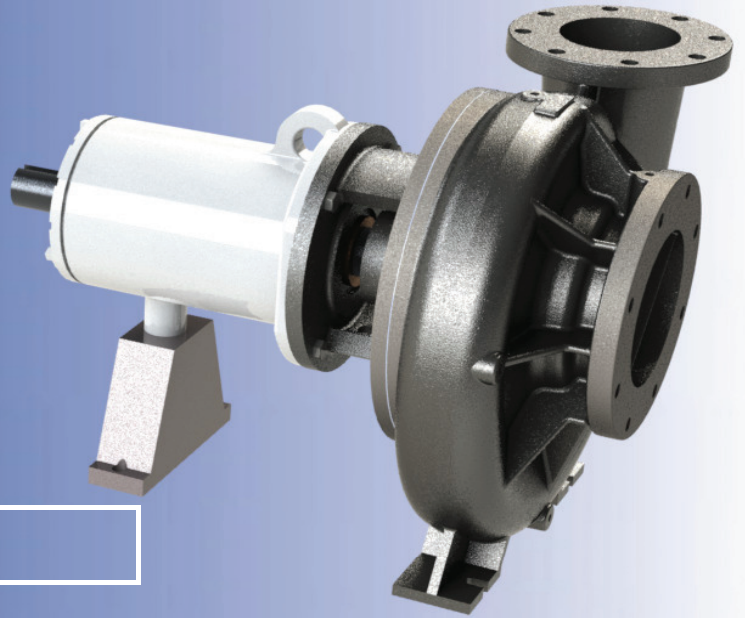

MATERIAL SPECIFICATIONS

PART NAME	Material
Casing, Cover & Impeller	Duplex 2205
Stub Shaft	17-4 PH
Adapter	Cast Iron

PERFORMANCE CURVE BASED ON WATER. A TOLERANCE OF ±1.5% APPLIES TO ALL FIGURES

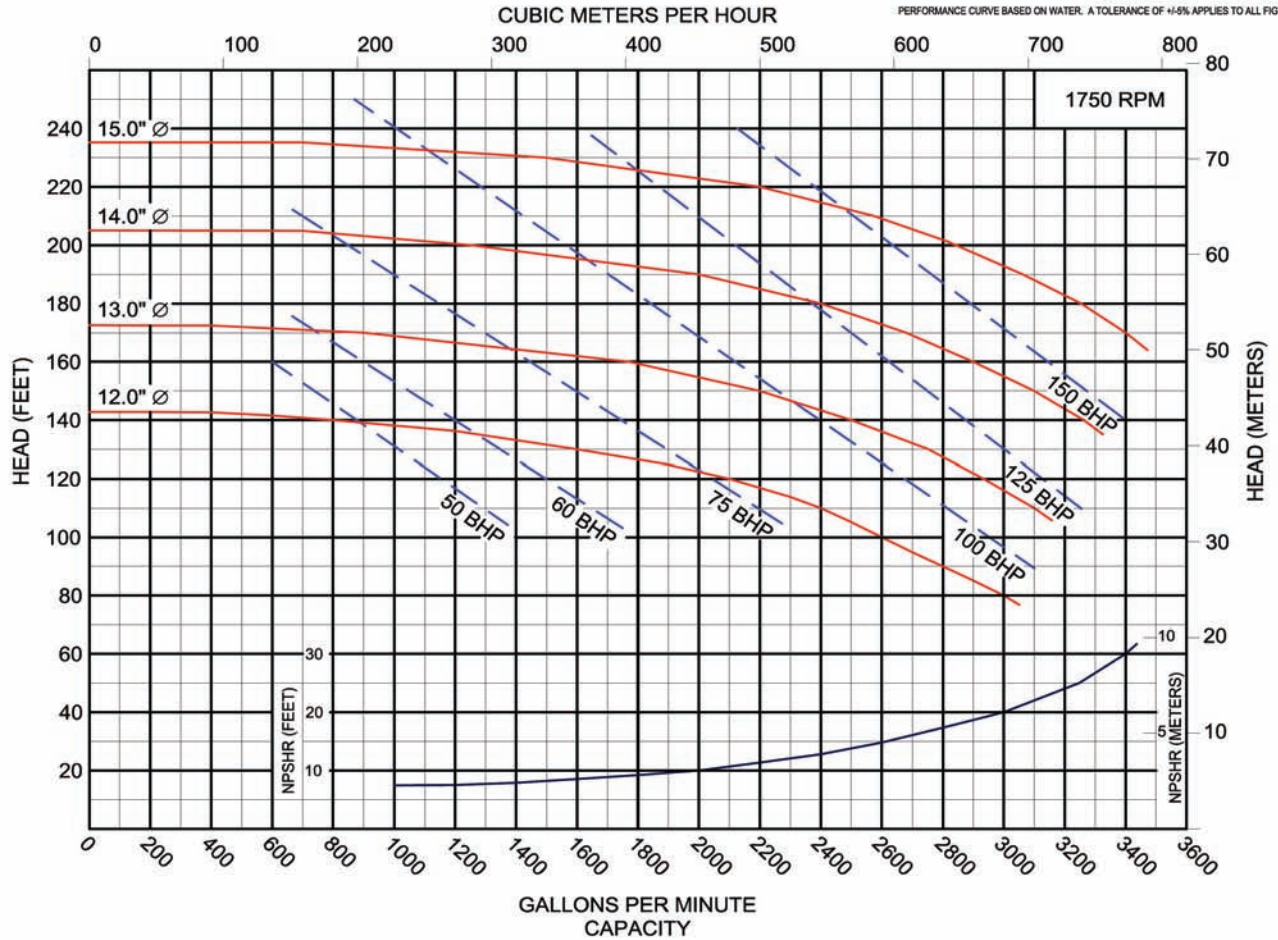

PERFORMANCE CURVE BASED ON WATER. A TOLERANCE OF ±1.5% APPLIES TO ALL FIGURES

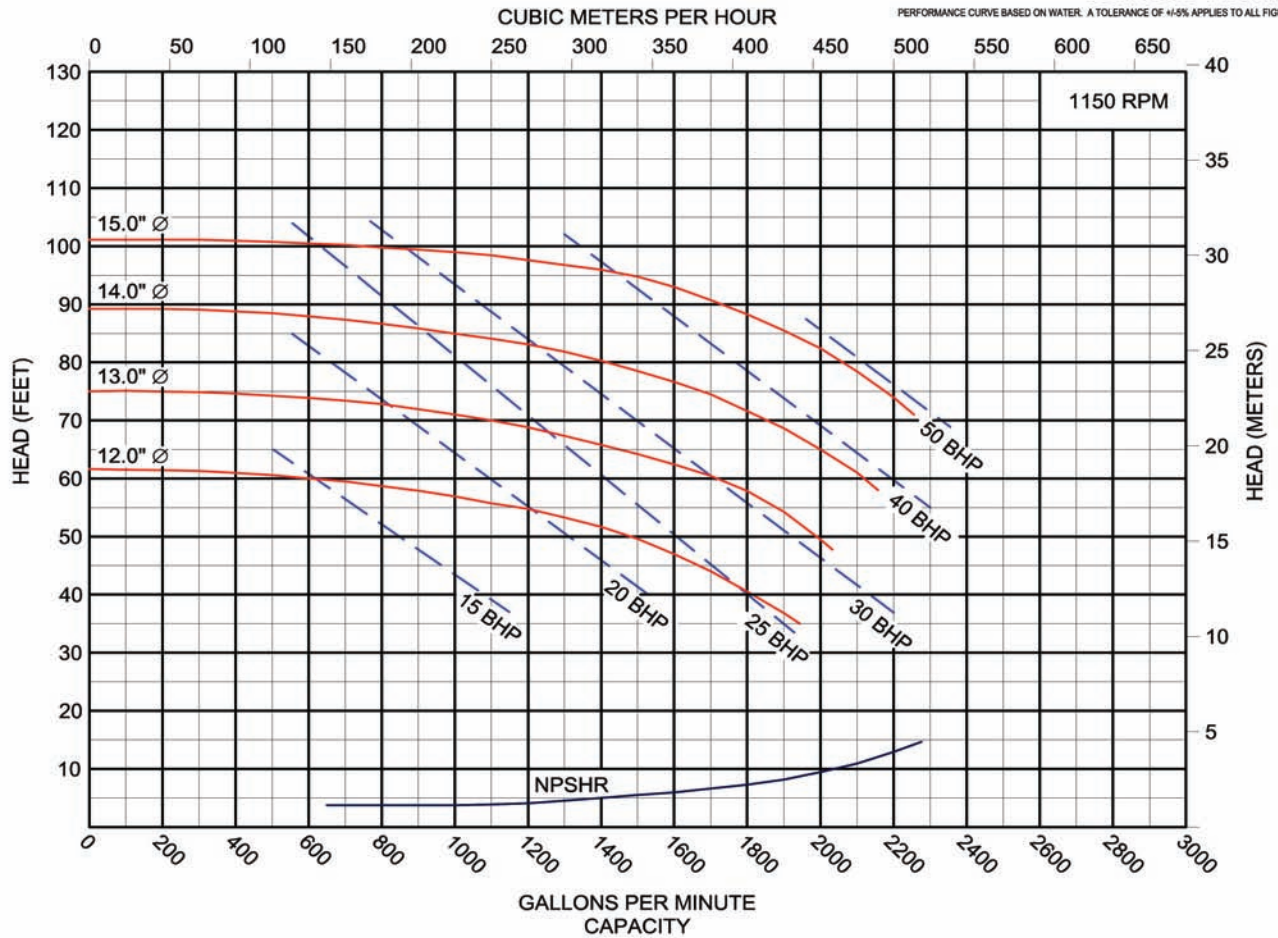

Ampco Centrifugal Pumps

DATA SHEET

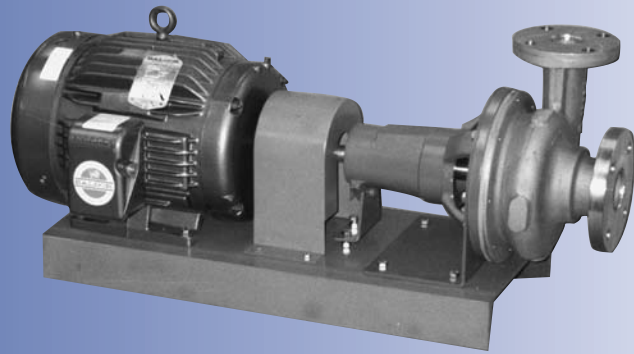

MODEL ZF 1 1/2 X 1 1/4
NICKEL ALUMINUM BRONZE

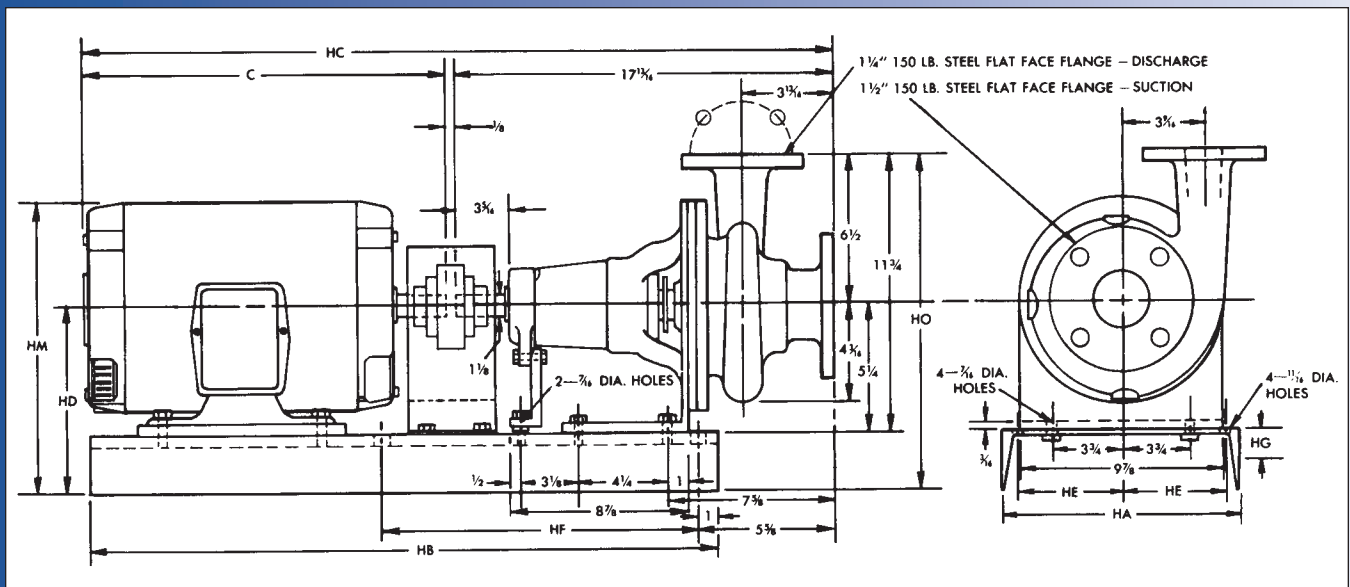

TEFC MOTOR			DIMENSIONS IN INCHES (For Reference Only)									
HP	RPM	FRAME	C	HA	HB	HC	HD	HE	HF	HG	HM	HO
1	1750	143T	13-1/16	10	26	31	7-7/8	3-3/4	24	2-5/8	11-3/4	14-3/8
2	3500	145T	13-1/16	10	26	31	7-7/8	3-3/4	24	2-5/8	11-3/4	14-3/8
3	3500	182T	15-3/8	10	26	33-5/16	7-7/8	3-3/4	16-1/4	2-5/8	12-1/2	14-3/8
5	3500	184T	15-3/8	10	26	33-5/16	7-7/8	3-3/4	16-1/4	2-5/8	12-1/2	14-3/8
7-1/2	3500	213T	19-7/16	12	28	37-3/8	8-1/4	4-1/2	17-1/2	3	13-3/4	14-3/4

MATERIAL SPECIFICATIONS

PART NAME	NICKEL ALUMINUM BRONZE
Casing, Cover & Impeller	AMPCO® 483
Wear Ring	AMPCO® 18
Shaft	Steel
Shaft Sleeve	AMPCO® 18
Frame	Cast Iron

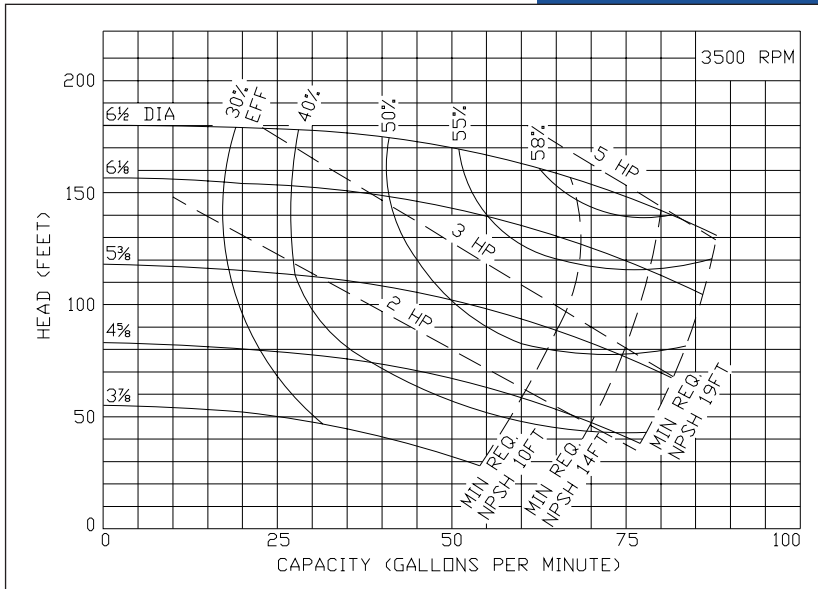

Ampco Centrifugal Pumps

**MODEL ZF 1 1/2 X 1 1/4
NICKEL ALUMINUM BRONZE**

Curves show approximate characteristics based on clear 68° water. Rated point is guaranteed.

Heavy-duty Z Series pumps have maximum wall thickness and 150 lb. flat faced flanged connections.

Seal options include Type 21, Type 1 and Type 9 with choice of sealing materials.

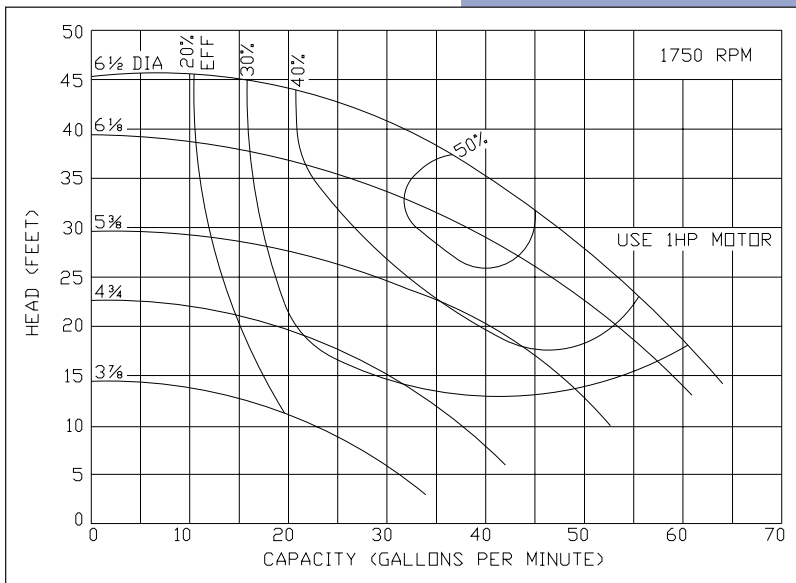
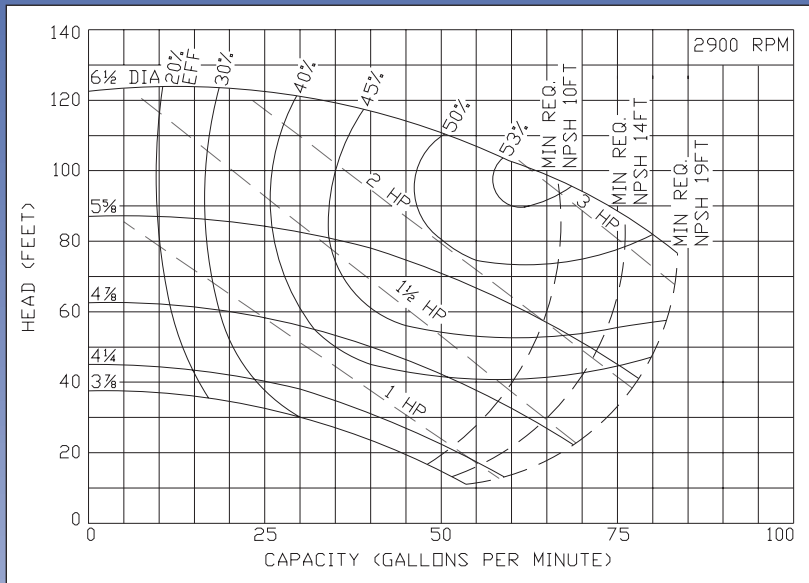

Ampco Pumps Company

4424 West Mitchell Street
Milwaukee, Wisconsin 53214
PHONE (414) 643-1852
FAX (414) 643-4452

Ampco Centrifugal Pumps

DATA SHEET

MODEL ZF 1½ X 1¼
STAINLESS STEEL

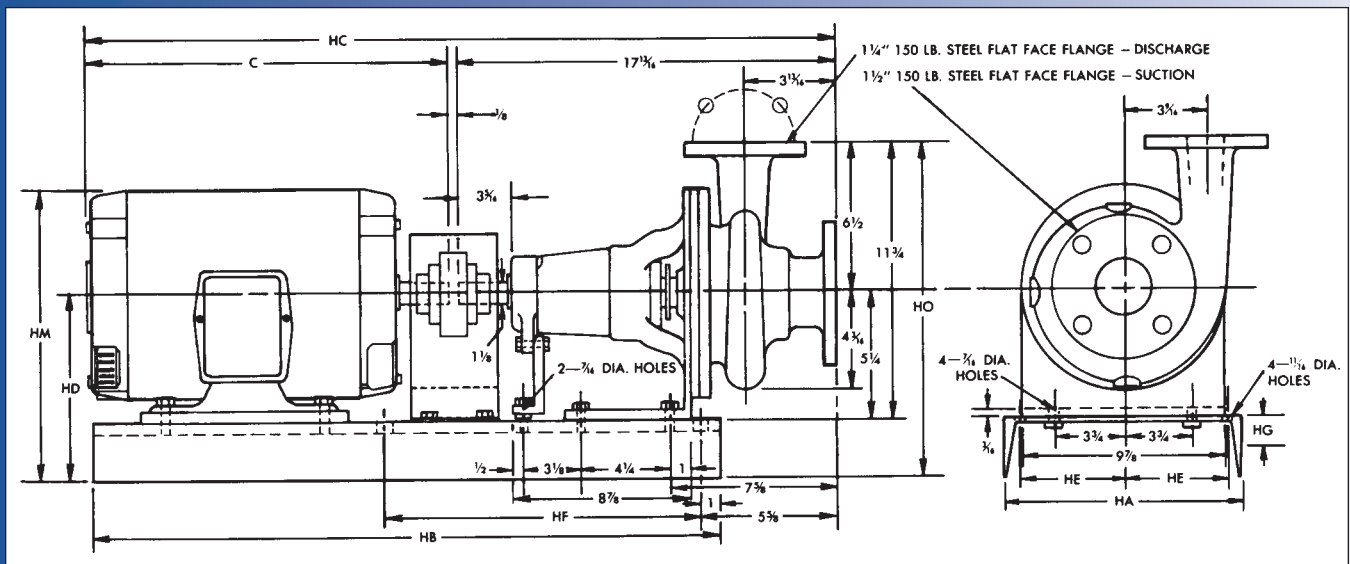
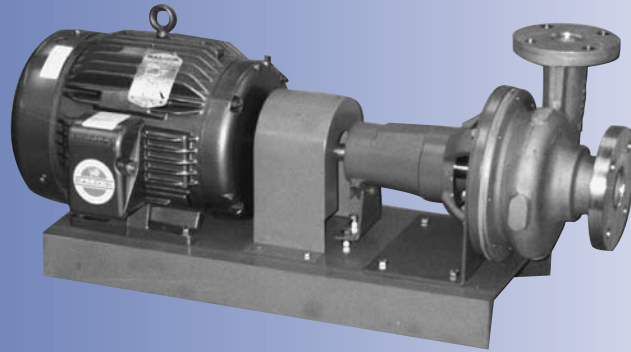

TEFC MOTOR			DIMENSIONS IN INCHES (For Reference Only)									
HP	RPM	FRAME	C	HA	HB	HC	HD	HE	HF	HG	HM	HO
1	1750	143T	13-1/16	10	26	31	7-7/8	3-3/4	24	2-5/8	11-3/4	14-3/8
2	3500	145T	13-1/16	10	26	31	7-7/8	3-3/4	24	2-5/8	11-3/4	14-3/8
3	3500	182T	15-3/8	10	26	33-5/16	7-7/8	3-3/4	16-1/4	2-5/8	12-1/2	14-3/8
5	3500	184T	15-3/8	10	26	33-5/16	7-7/8	3-3/4	16-1/4	2-5/8	12-1/2	14-3/8
7-1/2	3500	213T	19-7/16	12	28	37-3/8	8-1/4	4-1/2	17-1/2	3	13-3/4	14-3/4

MATERIAL SPECIFICATIONS

PART NAME	STAINLESS STEEL *
Casing, Cover & Impeller	316 Stainless
Wear Ring	316 Stainless
Shaft	Steel
Shaft Sleeve	316 Stainless
Frame	Cast Iron

* Also available in Duplex 2205

Ampco Centrifugal Pumps

MODEL ZF 1 1/2 X 1 1/4 STAINLESS STEEL

Curves show approximate characteristics based on clear 68° water. Rated point is guaranteed.

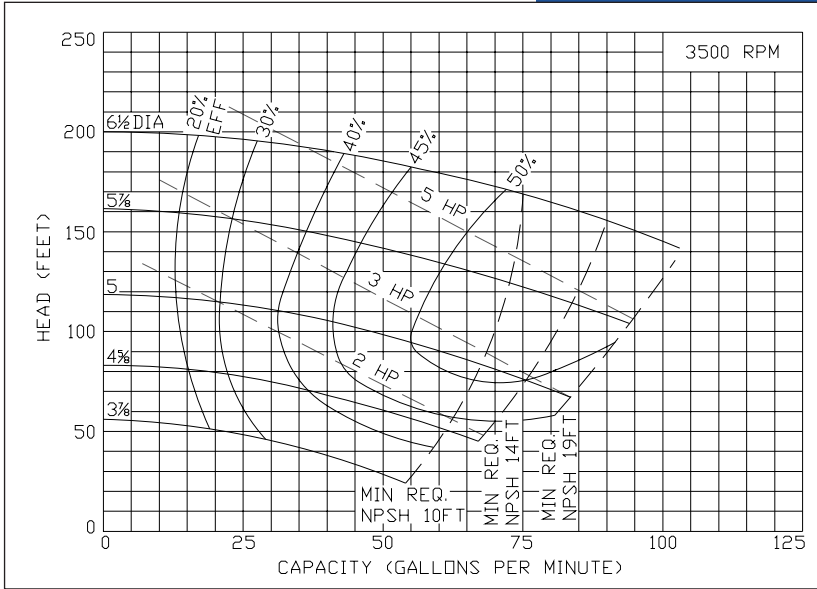

Heavy-duty Z Series pumps have maximum wall thickness and 150 lb. flat faced flanged connections.

Seal options include Type 21, Type 1 and Type 9 with choice of sealing materials.

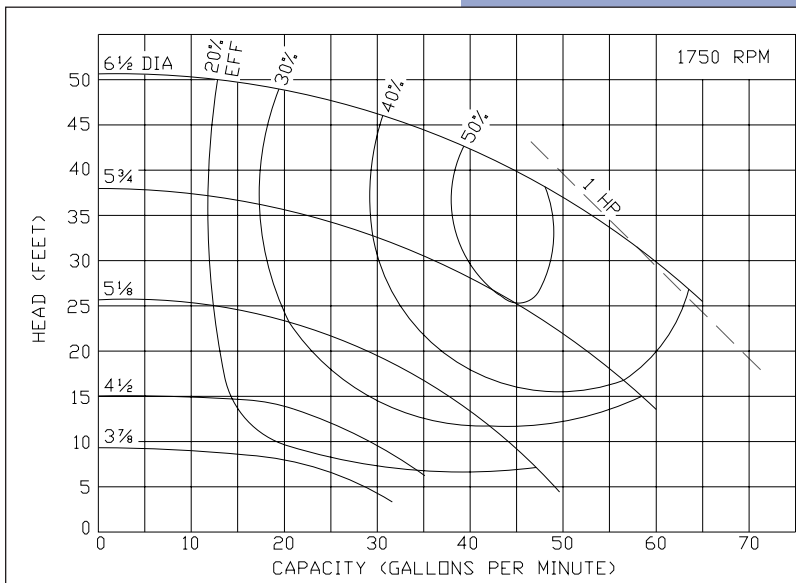
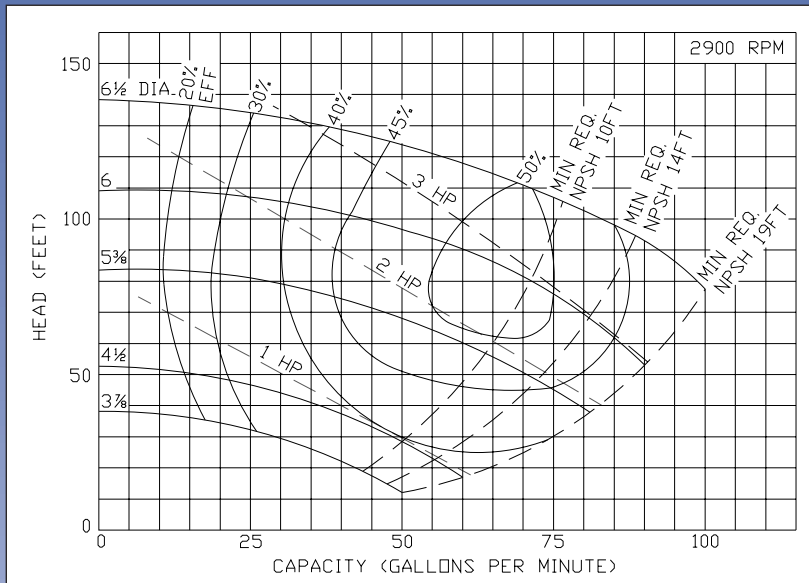

Ampco Pumps Company

4424 West Mitchell Street
Milwaukee, Wisconsin 53214
PHONE (414) 643-1852
FAX (414) 643-4452

Ampco Centrifugal Pumps

DATA SHEET

MODEL ZF 2 X 1 1/2

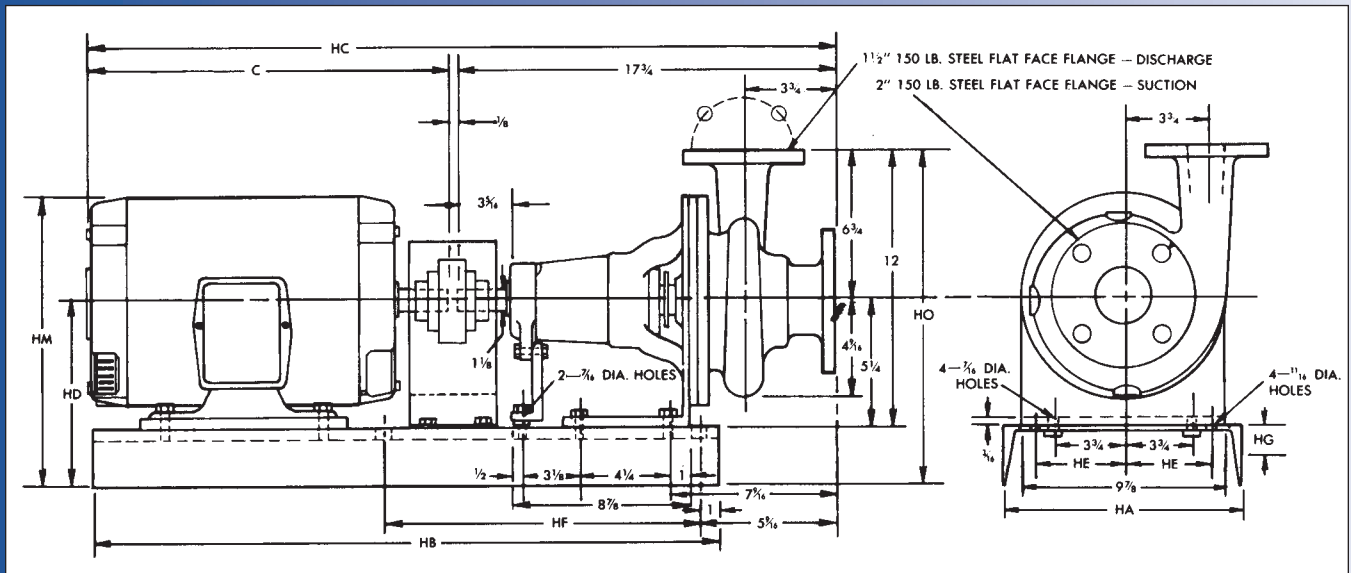
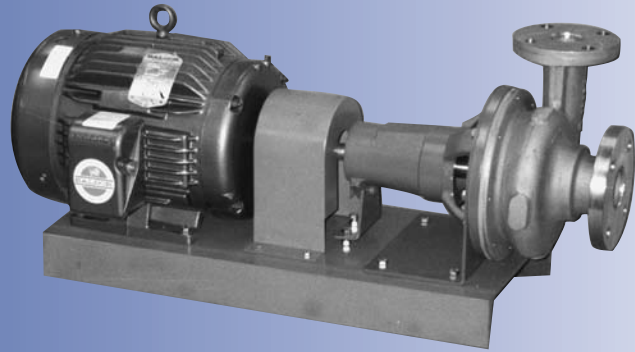

TEFC MOTOR			DIMENSIONS IN INCHES (For Reference Only)									
HP	RPM	FRAME	C	HA	HB	HC	HD	HE	HF	HG	HM	HO
1	1750	143T	13-1/16	10	26	30-15/16	7-7/8	3-3/4	24	2-5/8	11-3/4	14-5/8
2	3500	145T	13-1/16	10	26	30-15/16	7-7/8	3-3/4	24	2-5/8	11-3/4	14-3/8
3	3500	182T	15-3/8	10	26	33-1/4	7-7/8	3-3/4	16-1/4	2-5/8	12-1/2	14-3/8
5	3500	184T	15-3/8	10	26	33-1/4	7-7/8	3-3/4	16-1/4	2-5/8	12-1/2	14-3/8
7-1/2	3500	213T	19-7/16	12	28	37-5/16	8-1/4	4-1/2	17-1/2	3	13-3/4	15

MATERIAL SPECIFICATIONS

PART NAME	NICKEL ALUMINUM BRONZE	STAINLESS STEEL
Casing, Cover & Impeller	AMPCO® 483	316 Stainless
Wear Ring	AMPCO® 18	316 Stainless
Shaft	Steel	Steel
Shaft Sleeve	AMPCO® 18	316 Stainless
Frame	Cast Iron	Cast Iron

* Also available in Duplex 2205

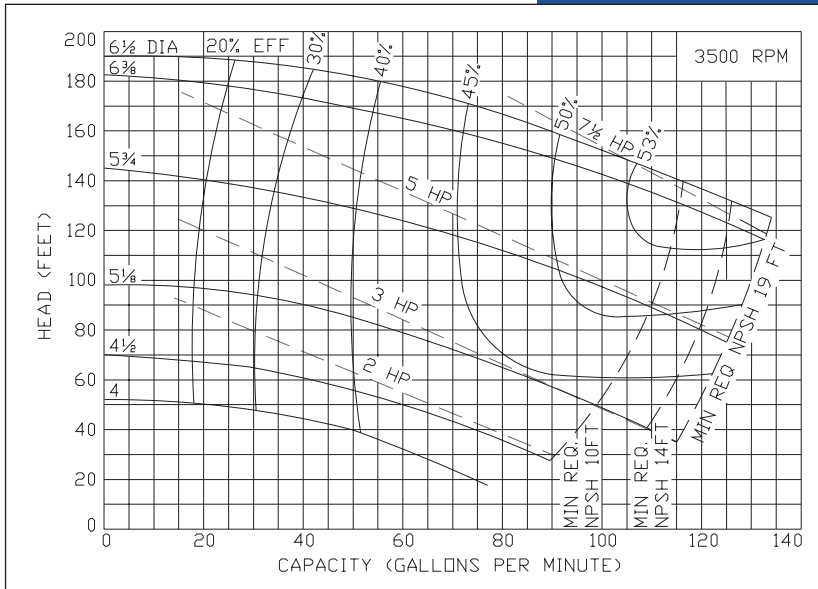

Ampco Centrifugal Pumps

MODEL ZF 2 X 1 1/2

Curves show approximate characteristics based on clear 68° water. Rated point is guaranteed.

Heavy-duty Z Series pumps have maximum wall thickness and 150 lb. flat faced flanged connections.

Seal options include Type 21, Type 1 and Type 9 with choice of sealing materials.

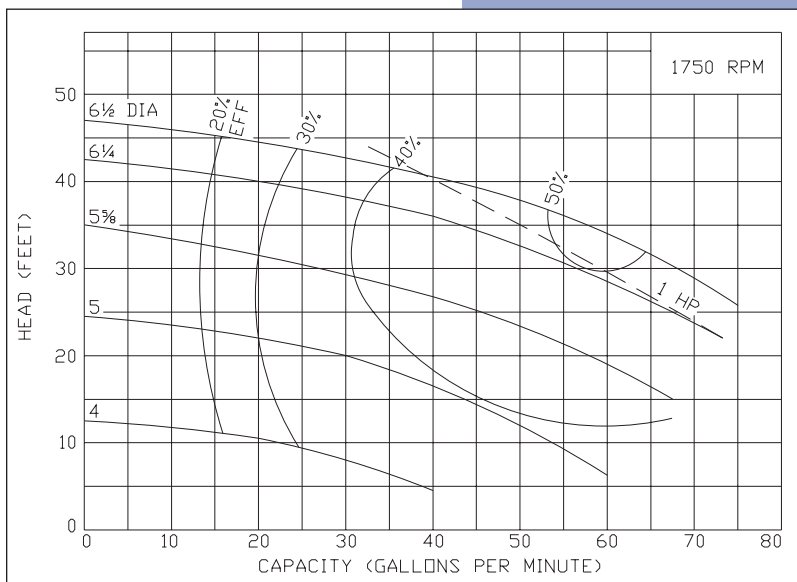
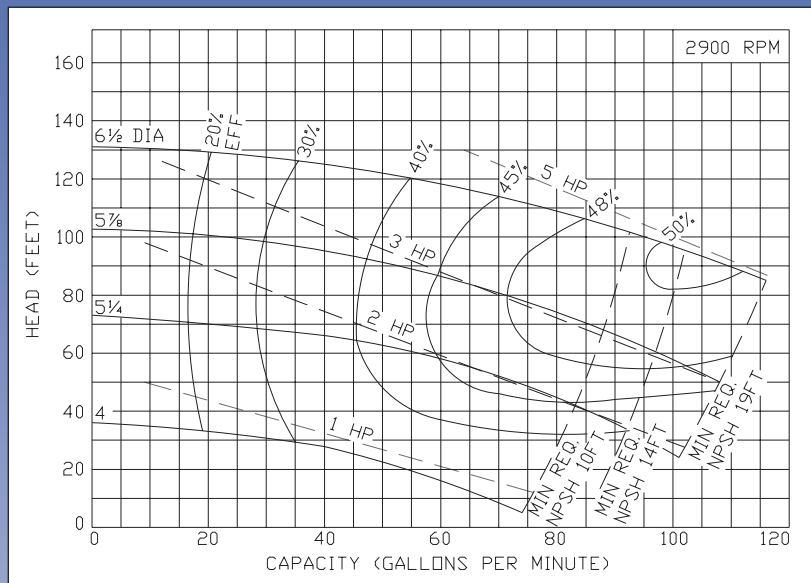

Ampco Pumps Company

4424 West Mitchell Street
 Milwaukee, Wisconsin 53214
 PHONE (414) 643-1852
 FAX (414) 643-4452

Ampco Centrifugal Pumps

DATA SHEET

MODEL ZF 2½X2

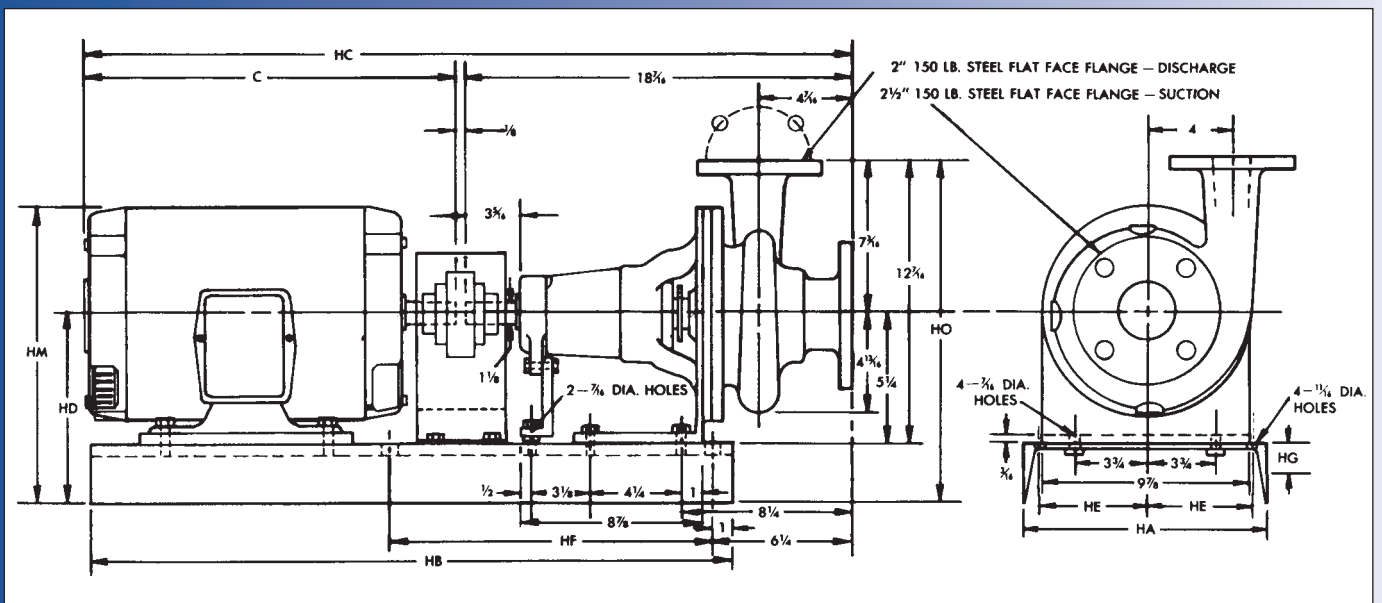
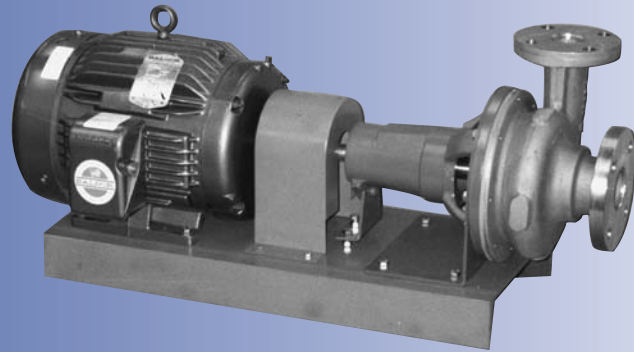

TEFC MOTOR			DIMENSIONS IN INCHES (For Reference Only)									
HP	RPM	FRAME	C	HA	HB	HC	HD	HE	HF	HG	HM	HO
2	1750	145T	13-1/16	10	26	31-5/8	7-7/8	2-3/4	14-1/4	2-5/8	11-3/4	15-1/16
3	3500	182T	15-3/8	10	26	33-15/16	7-7/8	3-3/4	16-1/4	2-5/8	12-1/2	15-1/16
5	3500	184T	15-3/8	10	26	33-15/16	7-7/8	3-3/4	16-1/4	2-5/8	12-1/2	15-1/16
7-1/2	3500	213T	19-7/16	12	28	38	8-1/4	4-1/2	17-1/2	3	13-3/4	15-7/16
10	3500	215T	19-7/16	12	28	38	8-1/4	4-1/2	17-1/2	3	13-3/4	15-7/16
15	3500	254T	24-9/16	15	34	43-1/8	9-5/8	6	18	3-3/8	15-15/16	16-13/16

MATERIAL SPECIFICATIONS

PART NAME	NICKEL ALUMINUM BRONZE	STAINLESS STEEL
Casing, Cover & Impeller	AMPCO® 483	316 Stainless
Wear Ring	AMPCO® 18	316 Stainless
Shaft	Steel	Steel
Shaft Sleeve	AMPCO® 18	316 Stainless
Frame	Cast Iron	Cast Iron

* Also available in Duplex 2205

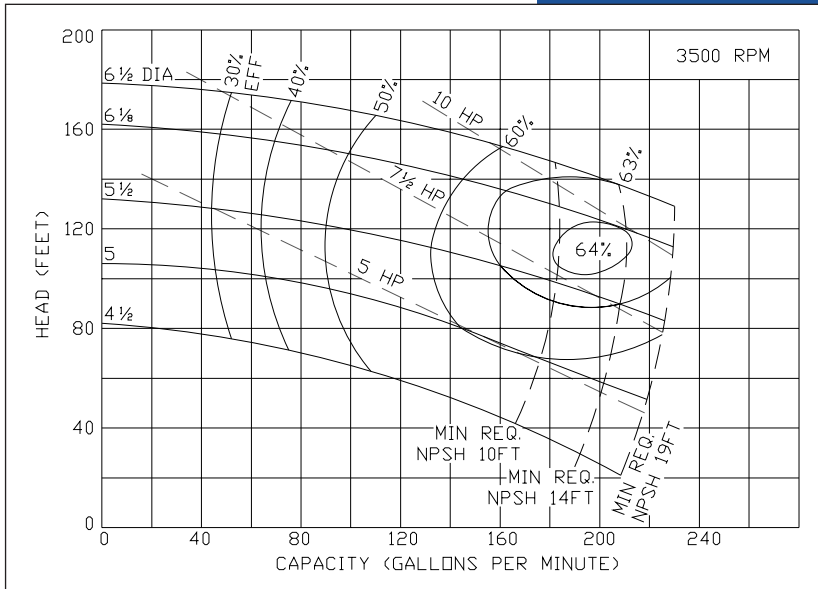

Ampco Centrifugal Pumps

MODEL ZF 2 1/2 X 2

Curves show approximate characteristics based on clear 68° water. Rated point is guaranteed.

Heavy-duty Z Series pumps have maximum wall thickness and 150 lb. flat faced flanged connections.

Seal options include Type 21, Type 1 and Type 9 with choice of sealing materials.

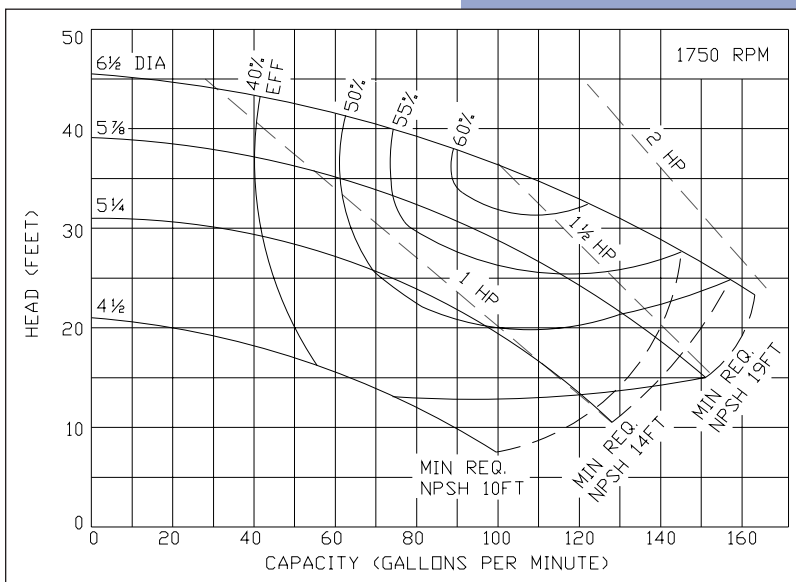
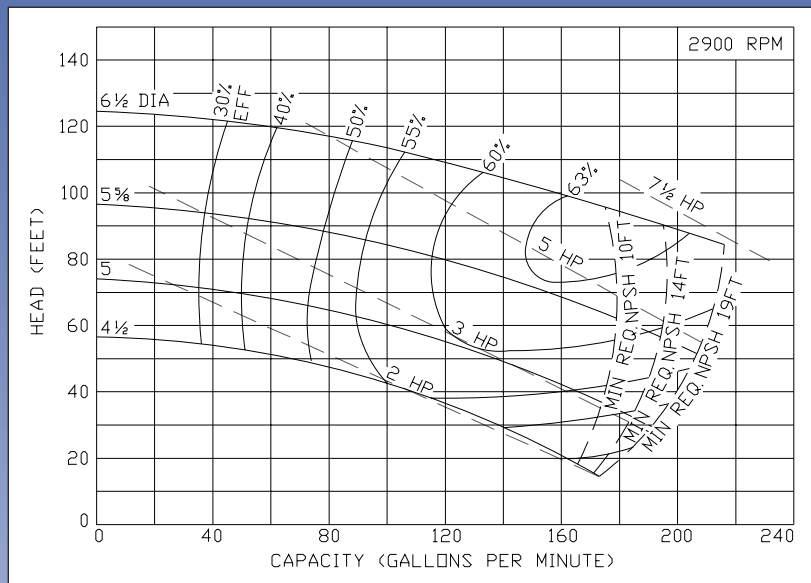

Ampco Pumps Company

4424 West Mitchell Street
 Milwaukee, Wisconsin 53214
 PHONE (414) 643-1852
 FAX (414) 643-4452

Ampco Centrifugal Pumps

DATA SHEET

MODEL ZF 3 X 2 1/2

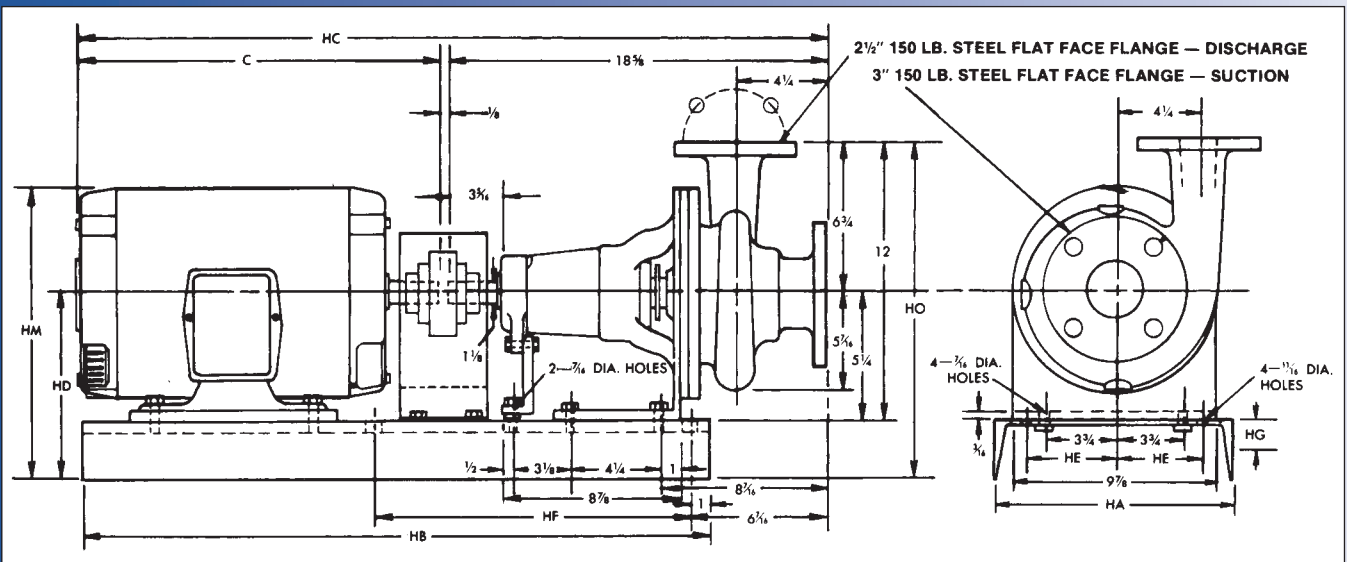
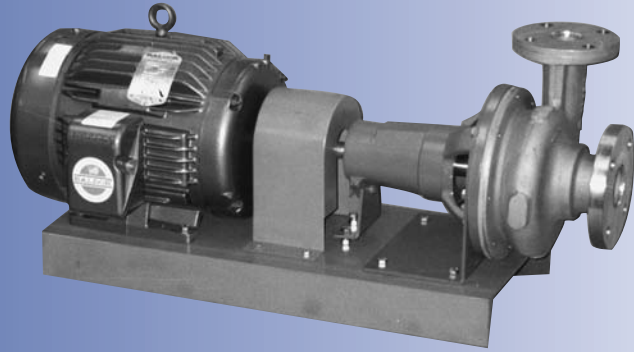

TEFC MOTOR			DIMENSIONS IN INCHES (For Reference Only)									
HP	RPM	FRAME	C	HA	HB	HC	HD	HE	HF	HG	HM	HO
3	3500	182T	15-3/8	10	26	34-1/8	7-7/8	3-3/4	16-1/4	2-5/8	12-1/2	14-5/8
5	3500	184T	15-3/8	10	26	34-1/8	7-7/8	3-3/4	16-1/4	2-5/8	12-1/2	14-5/8
7-1/2	3500	213T	19-7/16	12	28	38-3/16	8-1/4	4-1/2	17-1/2	3	13-3/4	15
10	3500	215T	19-7/16	12	28	38-3/16	8-1/4	4-1/2	17-1/2	3	13-3/4	15

Refer to EP/EPH data sheet for 15 HP and above.

MATERIAL SPECIFICATIONS

PART NAME	NICKEL ALUMINUM BRONZE	STAINLESS STEEL
Casing, Cover & Impeller	AMPCO® 483	316 Stainless
Wear Ring	AMPCO® 18	316 Stainless
Shaft	Steel	Steel
Shaft Sleeve	AMPCO® 18	316 Stainless
Frame	Cast Iron	Cast Iron

* Also available in Duplex 2205

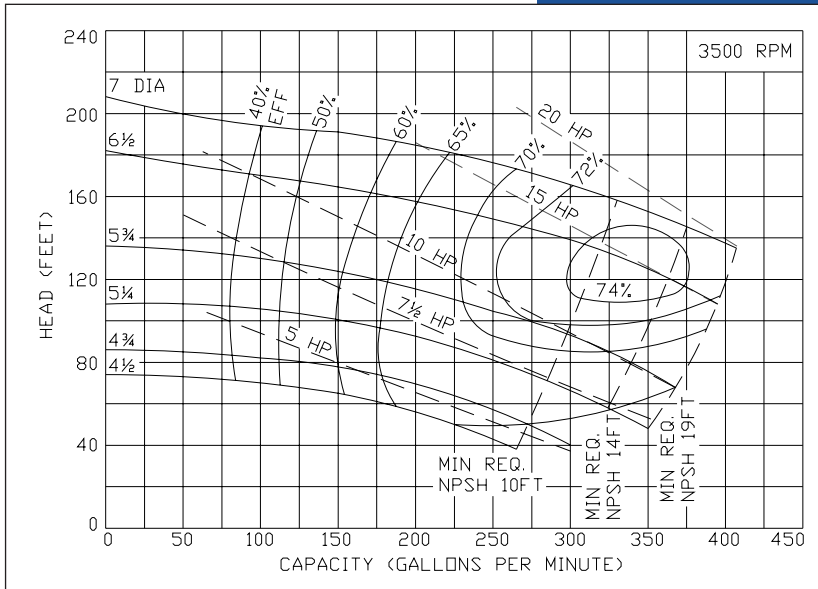

Ampco Centrifugal Pumps

MODEL ZF 3 X 2 1/2

Curves show approximate characteristics based on clear 68° water. Rated point is guaranteed.

Heavy-duty Z Series pumps have maximum wall thickness and 150 lb. flat faced flanged connections.

Seal options include Type 21, Type 1 and Type 9 with choice of sealing materials.

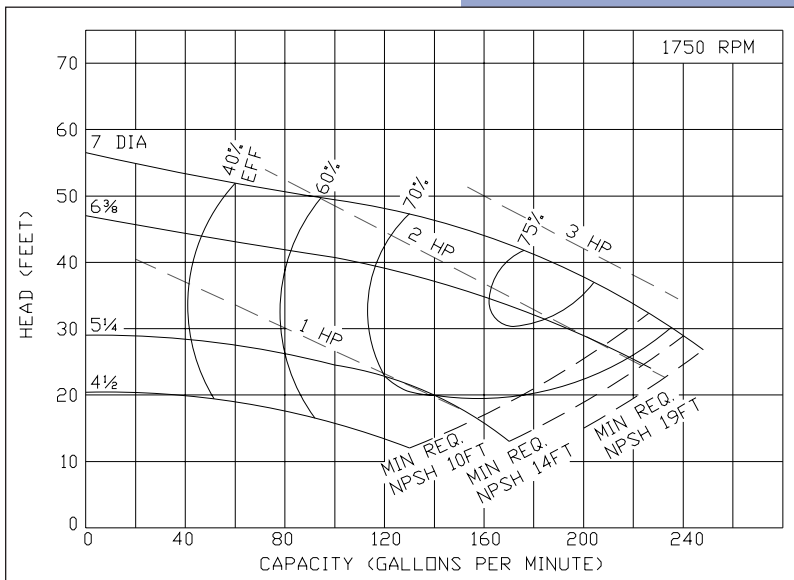
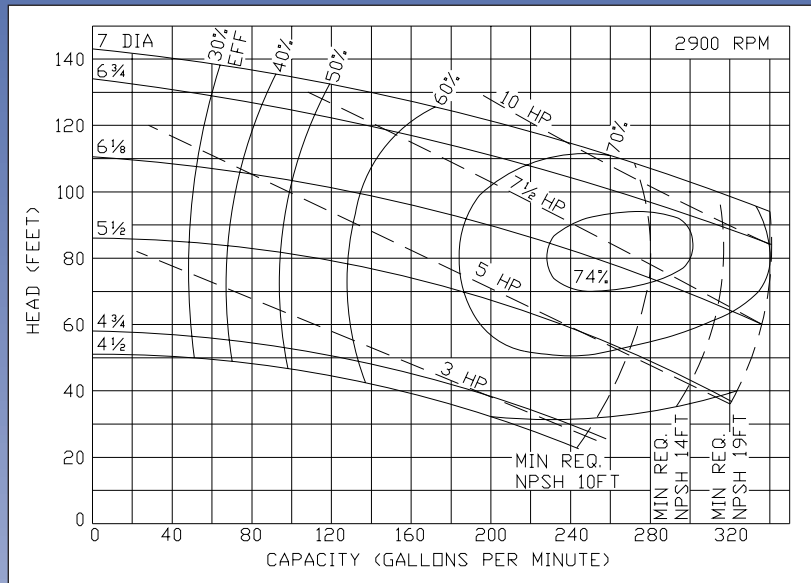

Ampco Pumps Company

4424 West Mitchell Street
 Milwaukee, Wisconsin 53214
 PHONE (414) 643-1852
 FAX (414) 643-4452

Ampco Centrifugal Pumps

DATA SHEET

MODEL ZF 4X3

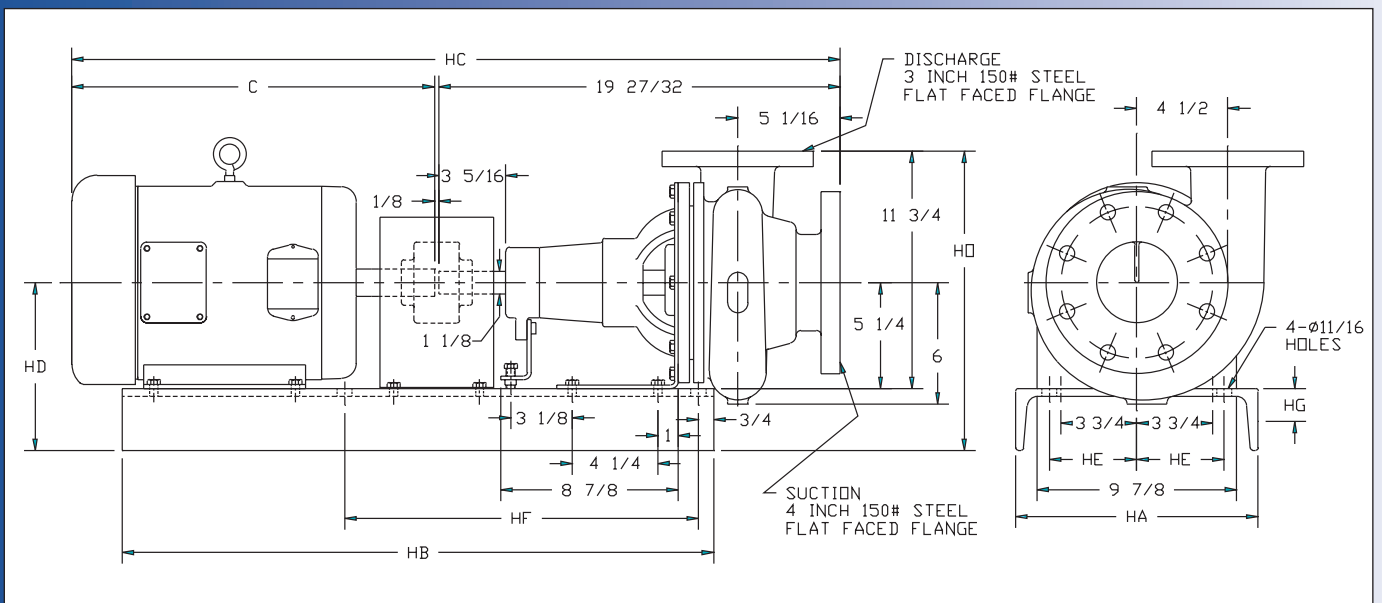
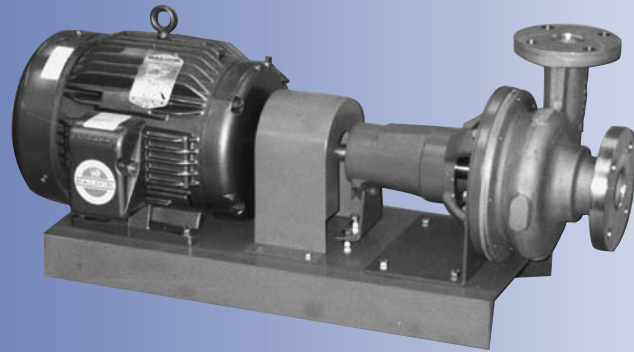

TEFC MOTOR			DIMENSIONS IN INCHES (For Reference Only)								
HP	RPM	FRAME	C	HA	HB	HC	HD	HE	HF	HG	HO
2	1750	145T	13-1/16	10	25-3/4	32-3/8	7-7/8	2-3/4	14-1/4	2-5/8	14-5/8
3	1700	182T	15-3/8	10	25-3/4	34-11/16	7-7/8	3-3/4	16-1/4	2-5/8	14-5/8
5	3500	184T	15-3/8	10	25-3/4	34-11/16	7-7/8	3-3/4	16-1/4	2-5/8	14-5/8
7-1/2	3500	213T	19-7/16	12	27-3/4	38-3/4	8-1/4	4-1/2	17-1/2	3	15
10	3500	215T	19-7/16	12	27-3/4	38-3/4	8-1/4	4-1/2	17-1/2	3	15
15	3500	254T	24-9/16	15	33-3/4	43-7/8	9-5/8	6	18	3-3/8	16-3/8

MATERIAL SPECIFICATIONS

PART NAME	NICKEL ALUMINUM BRONZE	STAINLESS STEEL
Casing, Cover & Impeller	AMPCO® 483	316 Stainless
Wear Ring	AMPCO® 18	316 Stainless
Shaft	Steel	Steel
Shaft Sleeve	AMPCO® 18	316 Stainless
Frame	Cast Iron	Cast Iron

* Also available in Duplex 2205

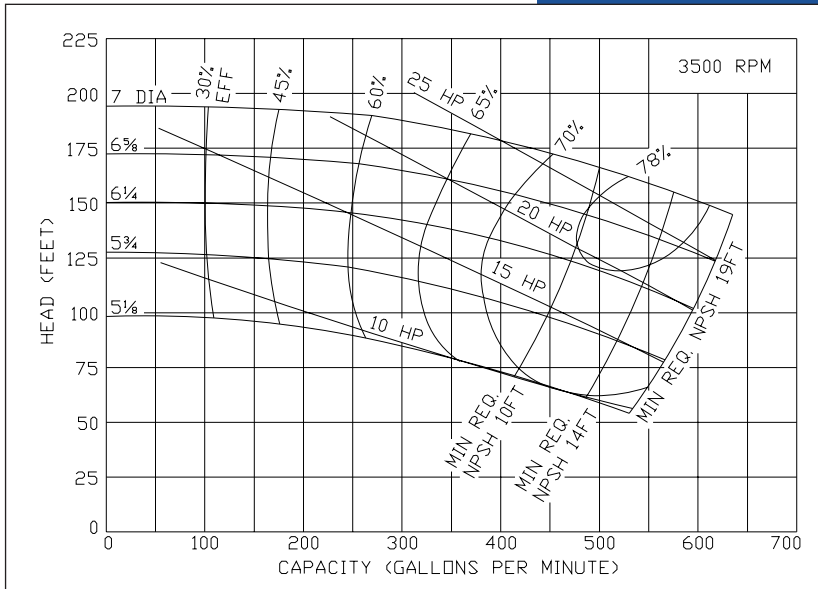

Ampco Centrifugal Pumps

MODEL ZF 4X3

Curves show approximate characteristics based on clear 68° water. Rated point is guaranteed.

Heavy-duty Z Series pumps have maximum wall thickness and 150 lb. flat faced flanged connections.

Seal options include Type 21, Type 1 and Type 9 with choice of sealing materials.

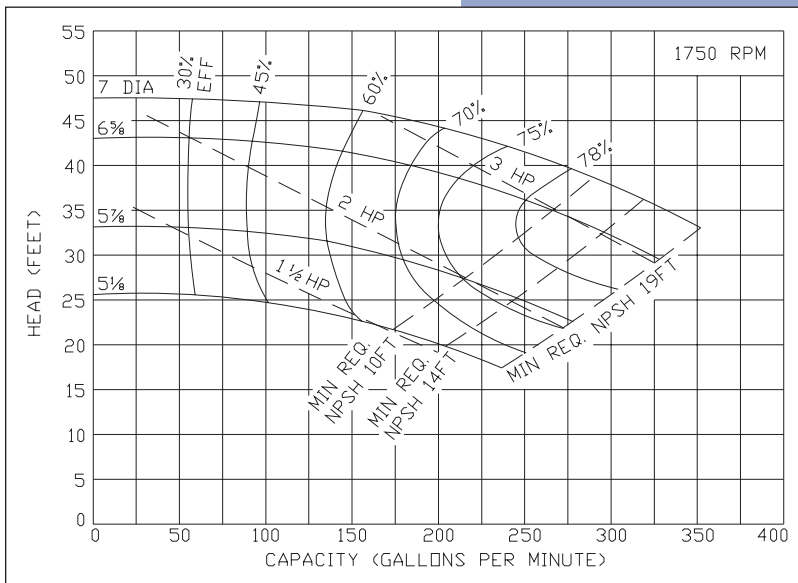
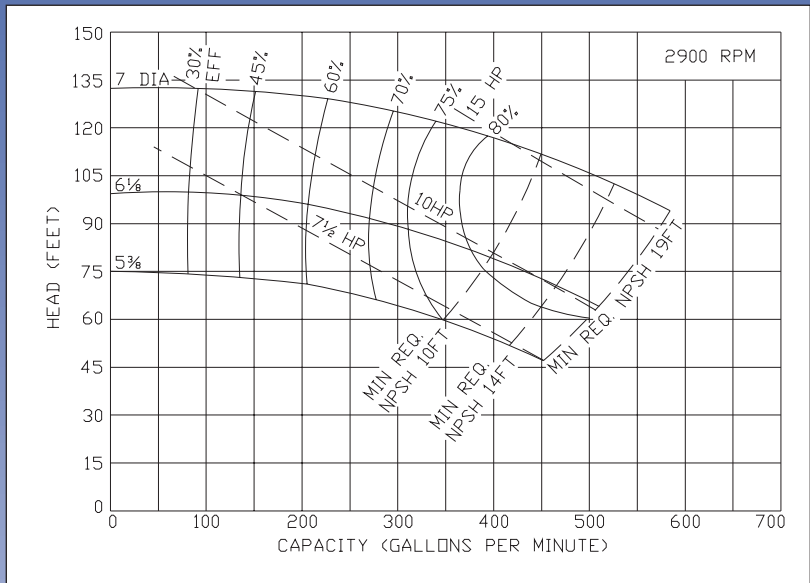

Ampco Pumps Company

4424 West Mitchell Street
 Milwaukee, Wisconsin 53214
 PHONE (414) 643-1852
 FAX (414) 643-4452