

# Ampco Centrifugal Pumps

## DATA SHEET

MODEL EC 1 1/2 X 1 1/4  
NICKEL ALUMINUM BRONZE

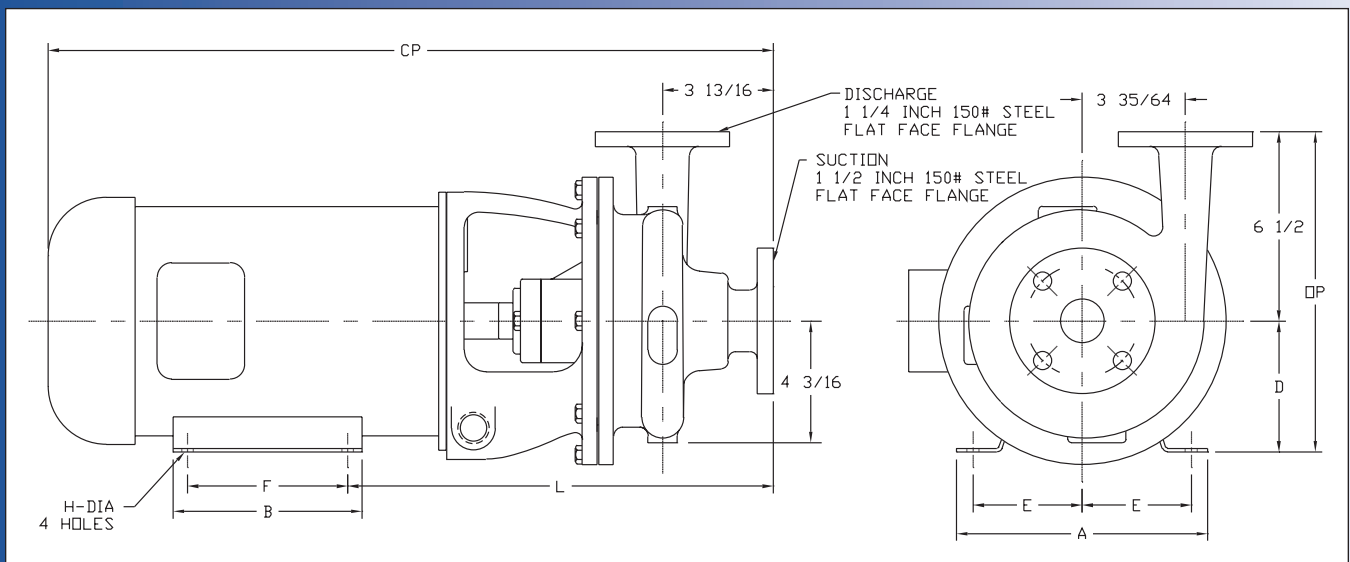
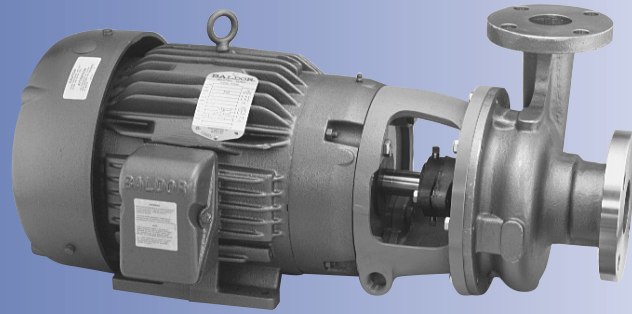

TEFC MOTOR			DIMENSIONS IN INCHES (For Reference Only)									APPROX. WEIGHT (LBS)
HP	RPM	FRAME	A (typ)	B (typ)	D	E	F	H	L	CP	OP	
3	1750	182TCZ	8-5/8	6-1/2	4-1/2	3-3/4	4-1/2	13/32	14-5/8	24-15/16	11	156
3	3500	182TCZ	8-5/8	6-1/2	4-1/2	3-3/4	4-1/2	13/32	14-5/8	24-15/16	11	156
5	3500	184TCZ	8-5/8	6-1/2	4-1/2	3-3/4	5-1/2	13/32	14-5/8	24-15/16	11	169
7-1/2	3500	213TCZ	9-1/2	8	5-1/4	4-1/4	5-1/2	13/32	15-1/4	26-9/16	11-3/4	237

## MATERIAL SPECIFICATIONS

PART NAME	NICKEL ALUMINUM BRONZE
Casing, Cover & Impeller	AMPCO® 483
Wear Ring	AMPCO® 18
Motor Shaft	Steel
Shaft Sleeve	AMPCO® 18
Adapter	Cast Iron



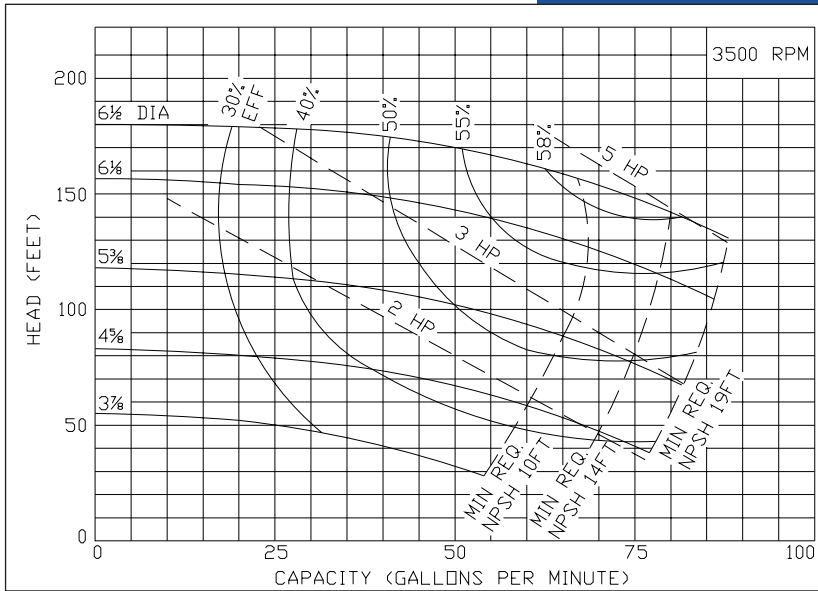

# Ampco Centrifugal Pumps

**MODEL EC 1 1/2 X 1 1/4**  
**NICKEL ALUMINUM BRONZE**

Curves show approximate characteristics based on clear 68° water. Rated point is guaranteed.

E Series pumps provide the same heavy-duty construction and hydraulic performance as Ampco's Z Series.

An enlarged stuffing box offers multiple sealing arrangements, including Type 21, Type 1, Type 9, Double Type 21, Double Type 9, packing and cartridge seals.

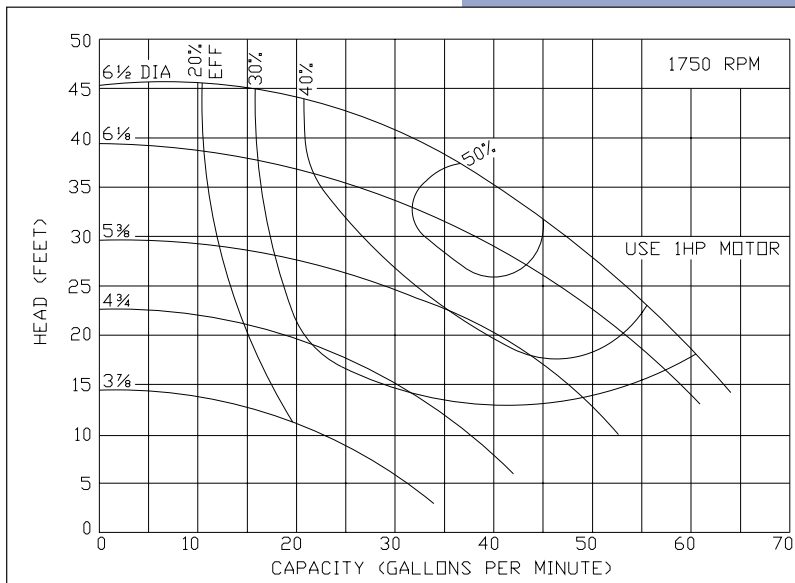
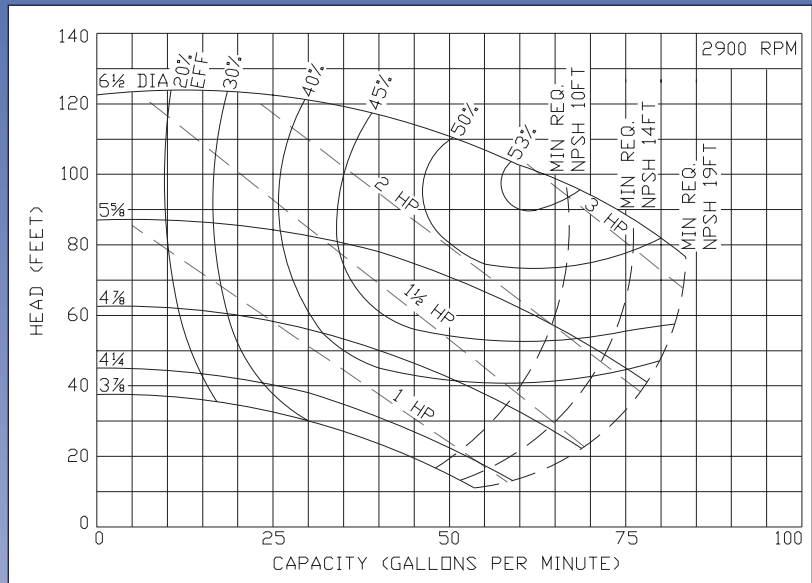

# Ampco Pumps Company

4424 West Mitchell Street  
 Milwaukee, Wisconsin 53214  
 PHONE (414) 643-1852  
 FAX (414) 643-4452

# Ampco Centrifugal Pumps

DATA SHEET

MODEL EC 1 1/2 X 1 1/4  
STAINLESS STEEL

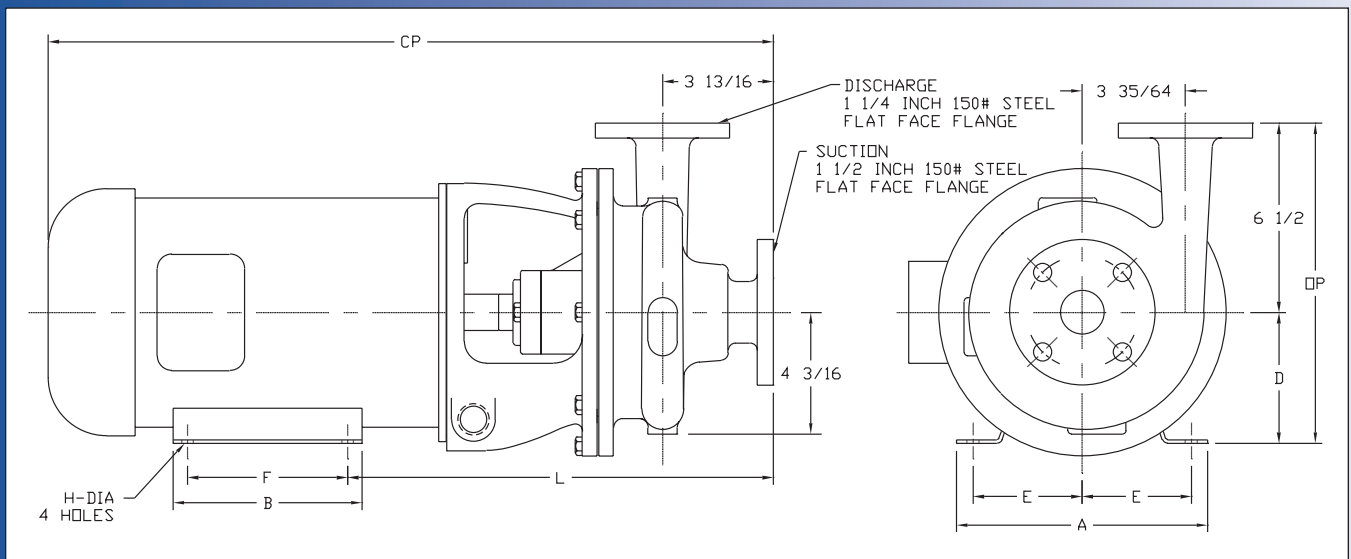
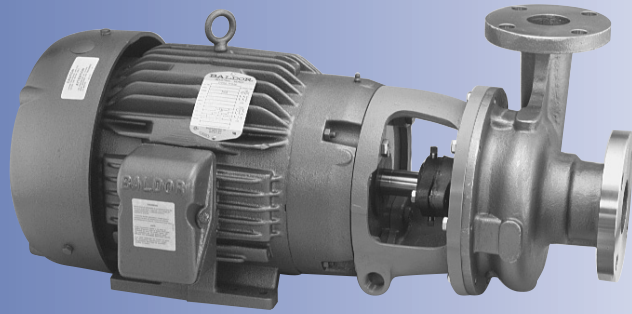

TEFC MOTOR			DIMENSIONS IN INCHES (For Reference Only)									APPROX. WEIGHT (LBS)
HP	RPM	FRAME	A (typ)	B (typ)	D	E	F	H	L	CP	OP	
3	1750	182TCZ	8-5/8	6-1/2	4-1/2	3-3/4	4-1/2	13/32	14-5/8	24-15/16	11	156
3	3500	182TCZ	8-5/8	6-1/2	4-1/2	3-3/4	4-1/2	13/32	14-5/8	24-15/16	11	156
5	3500	184TCZ	8-5/8	6-1/2	4-1/2	3-3/4	5-1/2	13/32	14-5/8	24-15/16	11	169
7-1/2	3500	213TCZ	9-1/2	8	5-1/4	4-1/4	5-1/2	13/32	15-1/4	26-9/16	11-3/4	237

## MATERIAL SPECIFICATIONS

PART NAME	STAINLESS STEEL
Casing, Cover & Impeller	316 Stainless
Wear Ring	316 Stainless
Motor Shaft	Steel
Shaft Sleeve	316 Stainless
Adapter	Cast Iron

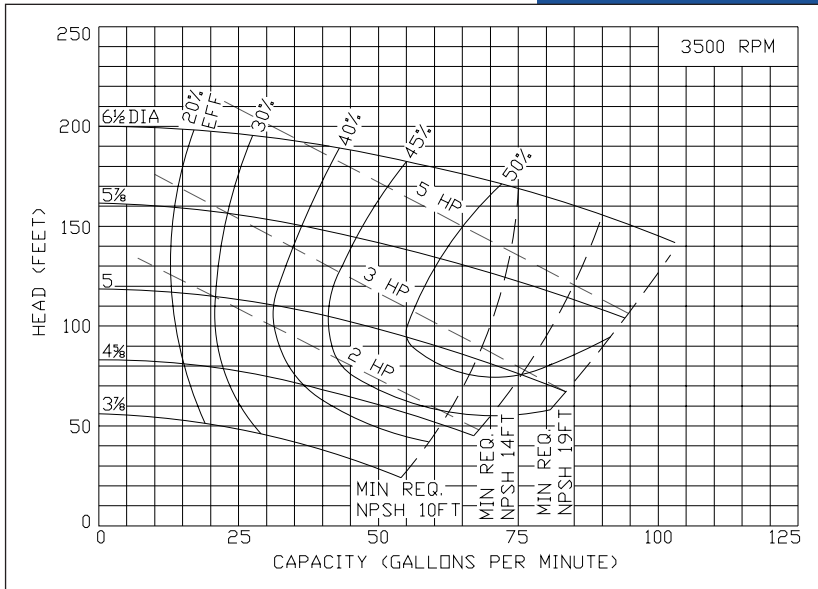

# Ampco Centrifugal Pumps

**MODEL EC 1 1/2 X 1 1/4  
STAINLESS STEEL**

Curves show approximate characteristics based on clear 68° water. Rated point is guaranteed.

E Series pumps provide the same heavy-duty construction and hydraulic performance as Ampco's Z Series.

An enlarged stuffing box offers multiple sealing arrangements, including Type 21, Type 1, Type 9, Double Type 21, Double Type 9, packing and cartridge seals.

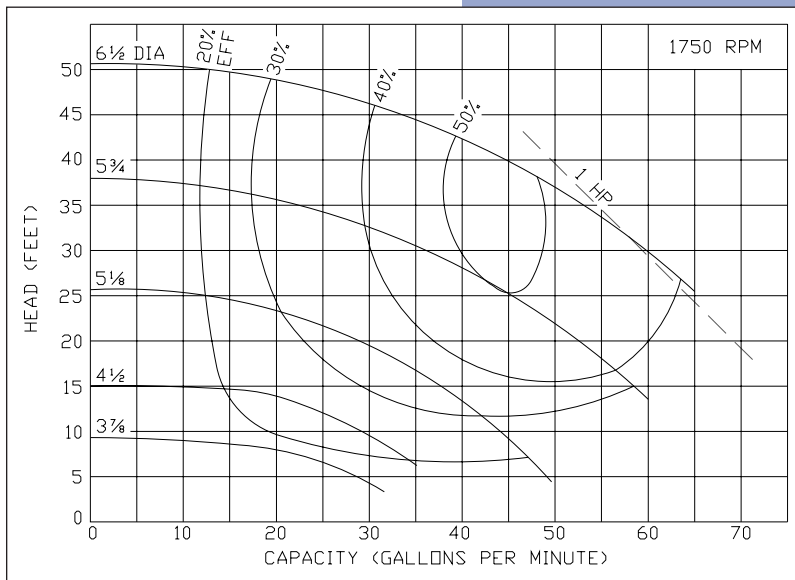
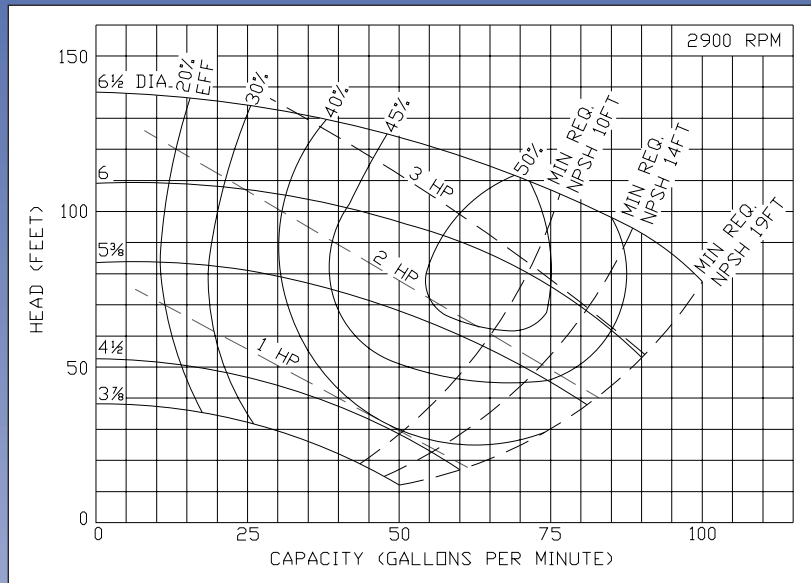

# Ampco Pumps Company

4424 West Mitchell Street  
Milwaukee, Wisconsin 53214  
PHONE (414) 643-1852  
FAX (414) 643-4452

# Ampco Centrifugal Pumps

DATA SHEET

MODEL EC 2 X 1 1/2

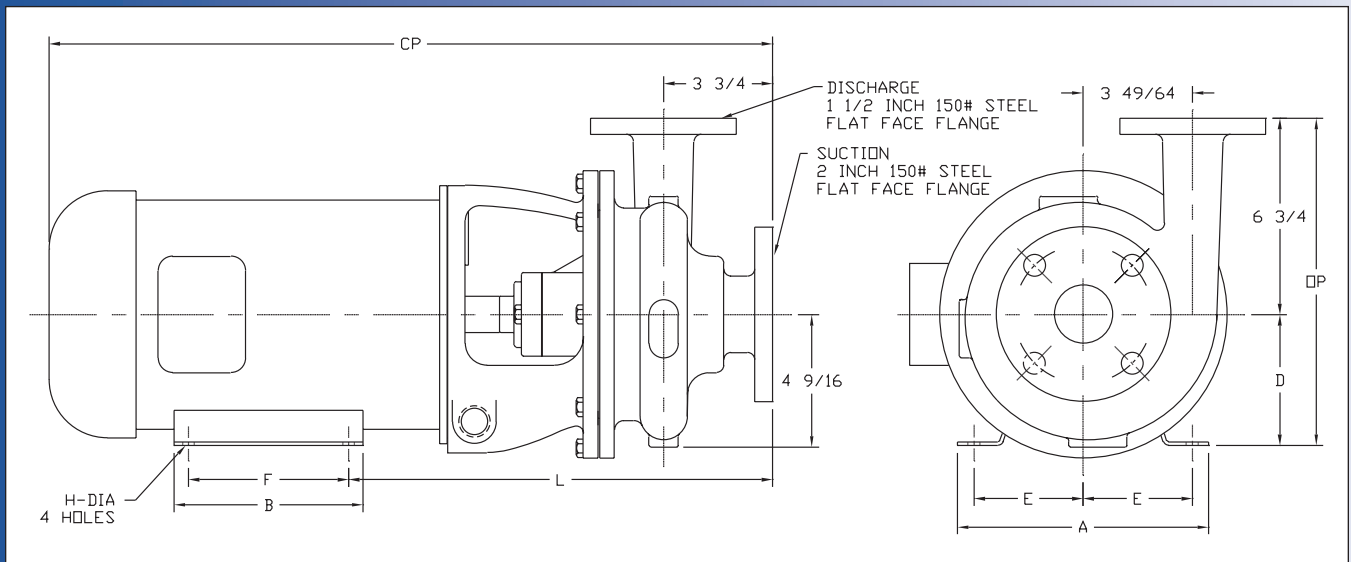
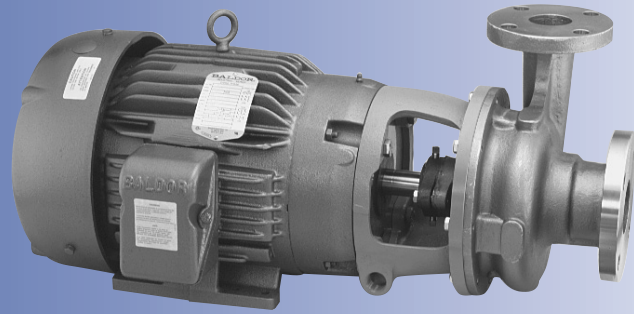

TEFC MOTOR			DIMENSIONS IN INCHES (For Reference Only)									APPROX. WEIGHT (LBS)
HP	RPM	FRAME	A (typ)	B (typ)	D	E	F	H	L	CP	OP	
3	1750	182TCZ	8-5/8	8-5/8	4-1/2	3-3/4	4-1/2	13/32	14-9/16	24-7/8	11-1/4	164
3	3500	182TCZ	8-5/8	8-5/8	4-1/2	3-3/4	4-1/2	13/32	14-9/16	24-7/8	11-1/4	159
5	3500	184TCZ	8-5/8	8-5/8	4-1/2	3-3/4	5-1/2	13/32	14-9/16	24-7/8	11-1/4	172
7-1/2	3500	213TCZ	9-1/2	9-1/2	5-1/4	4-1/4	5-1/2	13/32	15-3/16	26-1/2	12	240
10	3500	215TCZ	9-1/2	9-1/2	5-1/4	4-1/4	7	13/32	15-3/16	26-1/2	12	262

## MATERIAL SPECIFICATIONS

PART NAME	NICKEL ALUMINUM BRONZE	STAINLESS STEEL
Casing, Cover & Impeller	AMPCO® 483	316 Stainless
Wear Ring	AMPCO® 18	316 Stainless
Motor Shaft	Steel	Steel
Shaft Sleeve	AMPCO® 18	316 Stainless
Adapter	Cast Iron	Cast Iron

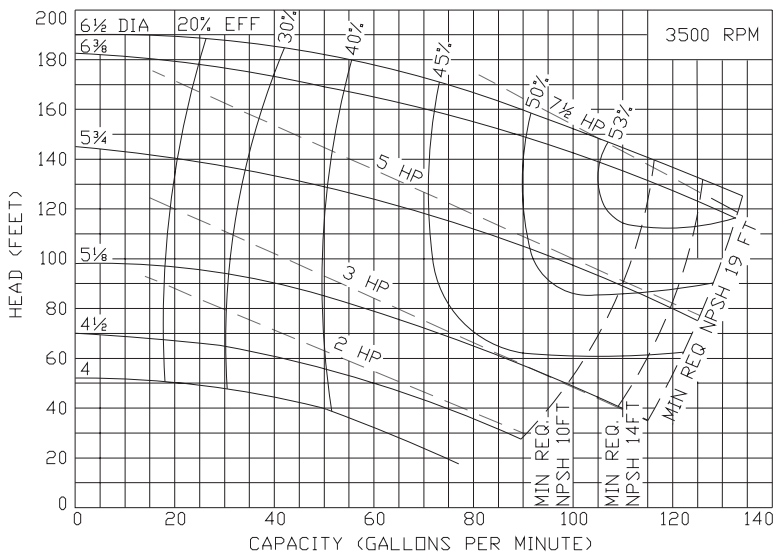

# Ampco Centrifugal Pumps

## MODEL EC 2 X 1 1/2

Curves show approximate characteristics based on clear 68° water. Rated point is guaranteed.

E Series pumps provide the same heavy-duty construction and hydraulic performance as Ampco's Z Series.

An enlarged stuffing box offers multiple sealing arrangements, including Type 21, Type 1, Type 9, Double Type 21, Double Type 9, packing and cartridge seals.

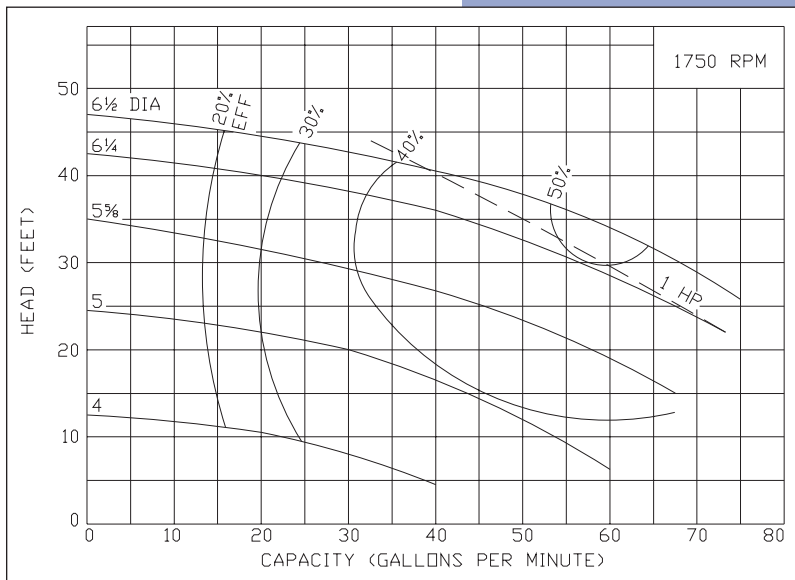
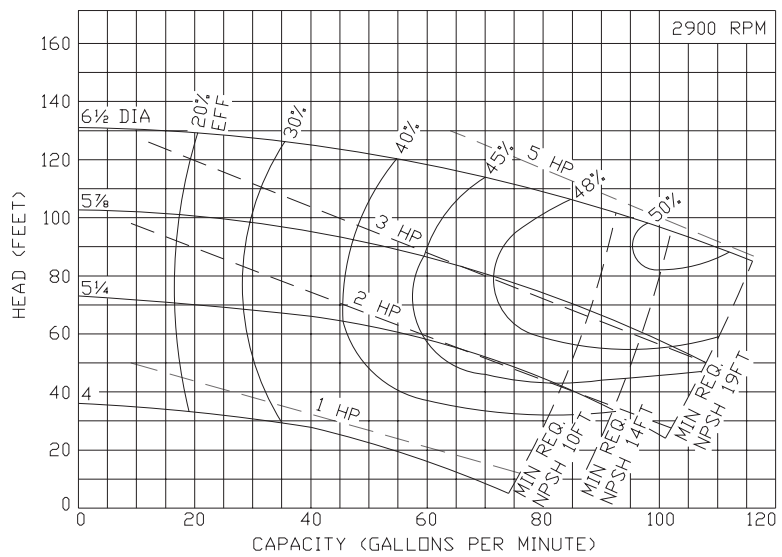

# Ampco Pumps Company

4424 West Mitchell Street  
 Milwaukee, Wisconsin 53214  
 PHONE (414) 643-1852  
 FAX (414) 643-4452

# Ampco Centrifugal Pumps

DATA SHEET

MODEL EC 2 1/2 X 2

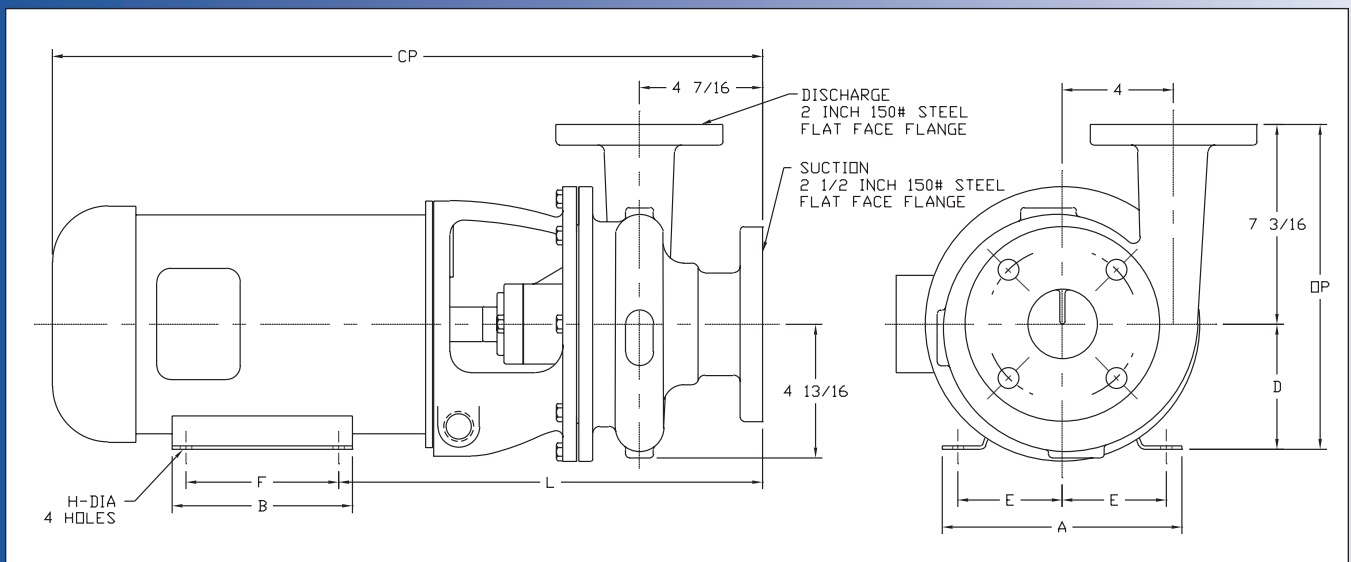
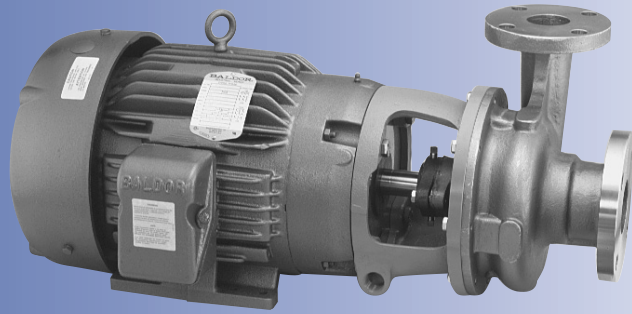

TEFC MOTOR			DIMENSIONS IN INCHES (For Reference Only)									APPROX. WEIGHT (LBS)
HP	RPM	FRAME	A (typ)	B (typ)	D	E	F	H	L	CP	OP	
3	1750	182TCZ	8-5/8	6-1/2	4-1/2	3-3/4	4-1/2	13/32	14-9/16	24-5/8	11-11/16	166
5	3500	184TCZ	8-5/8	6-1/2	4-1/2	3-3/4	5-1/2	13/32	14-9/16	24-5/8	11-11/16	179
7-1/2	3500	213TCZ	9-1/2	8	5-1/4	4-1/4	5-1/2	13/32	15-3/16	26-1/2	12-7/16	246
10	3500	215TCZ	9-1/2	8	5-1/4	4-1/4	7	13/32	15-3/16	26-1/2	12-7/16	265
15	3500	215TCZ	9-1/8	8	5-1/4	4-1/4	7	13/32	15-3/16	27-5/8	12-7/16	362

## MATERIAL SPECIFICATIONS

PART NAME	NICKEL ALUMINUM BRONZE	STAINLESS STEEL
Casing, Cover & Impeller	AMPCO® 483	316 Stainless
Wear Ring	AMPCO® 18	316 Stainless
Motor Shaft	Steel	Steel
Shaft Sleeve	AMPCO® 18	316 Stainless
Adapter	Cast Iron	Cast Iron

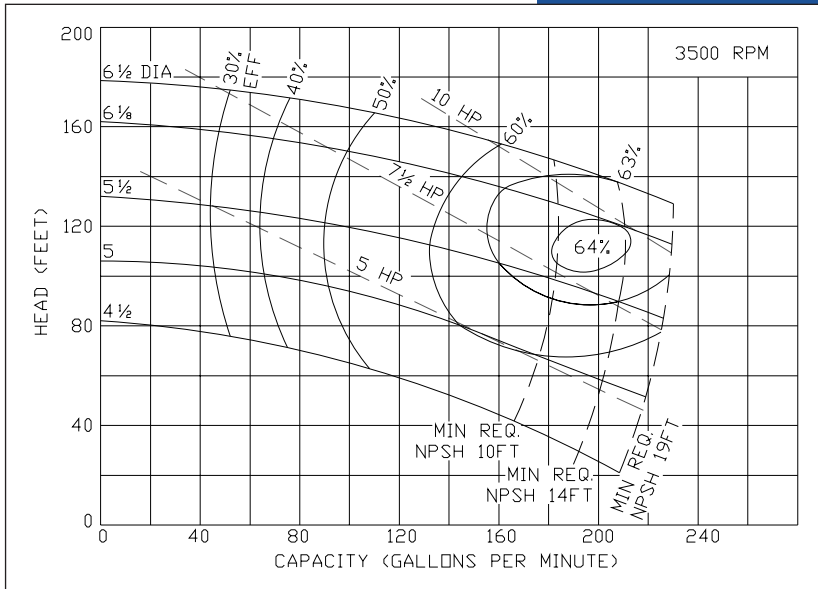

# Ampco Centrifugal Pumps

## MODEL EC 2 1/2 X 2

Curves show approximate characteristics based on clear 68° water. Rated point is guaranteed.

E Series pumps provide the same heavy-duty construction and hydraulic performance as Ampco's Z Series.

An enlarged stuffing box offers multiple sealing arrangements, including Type 21, Type 1, Type 9, Double Type 21, Double Type 9, packing and cartridge seals.

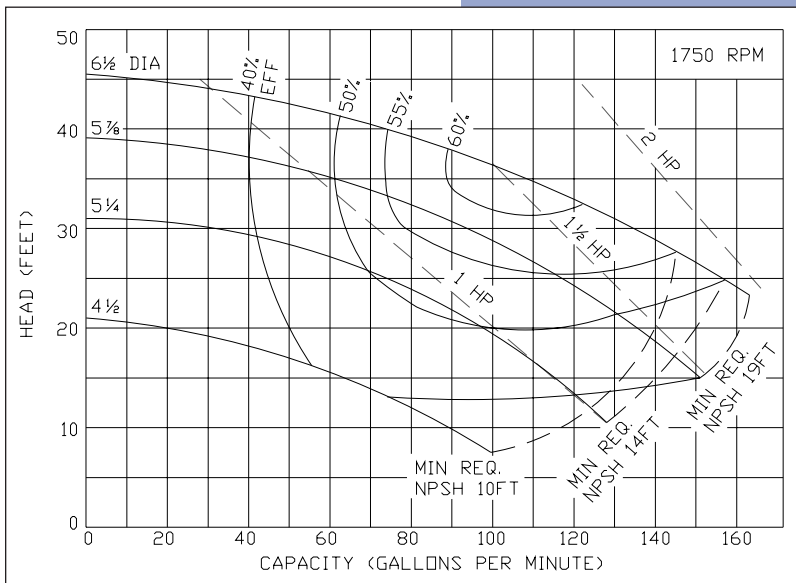
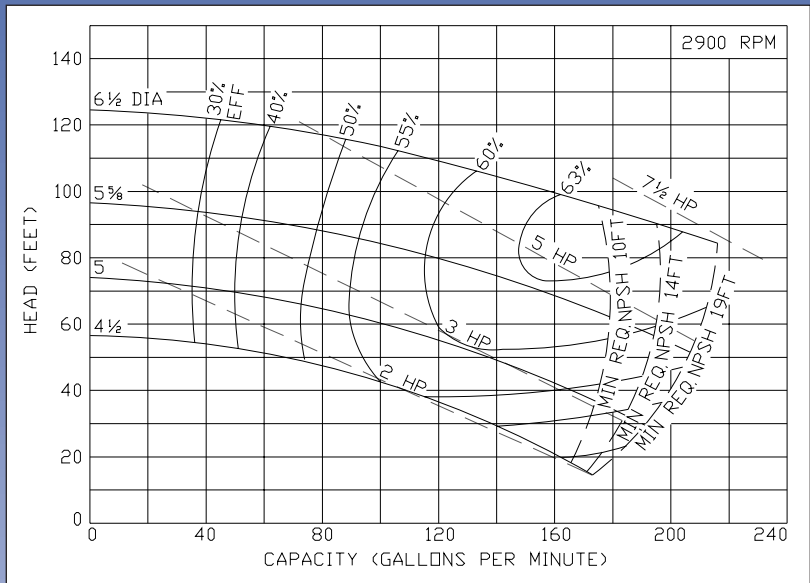

# Ampco Pumps Company

4424 West Mitchell Street  
 Milwaukee, Wisconsin 53214  
 PHONE (414) 643-1852  
 FAX (414) 643-4452



# Ampco Centrifugal Pumps

## DATA SHEET

MODEL EC/ECH 3X2<sup>1</sup>/<sub>2</sub>

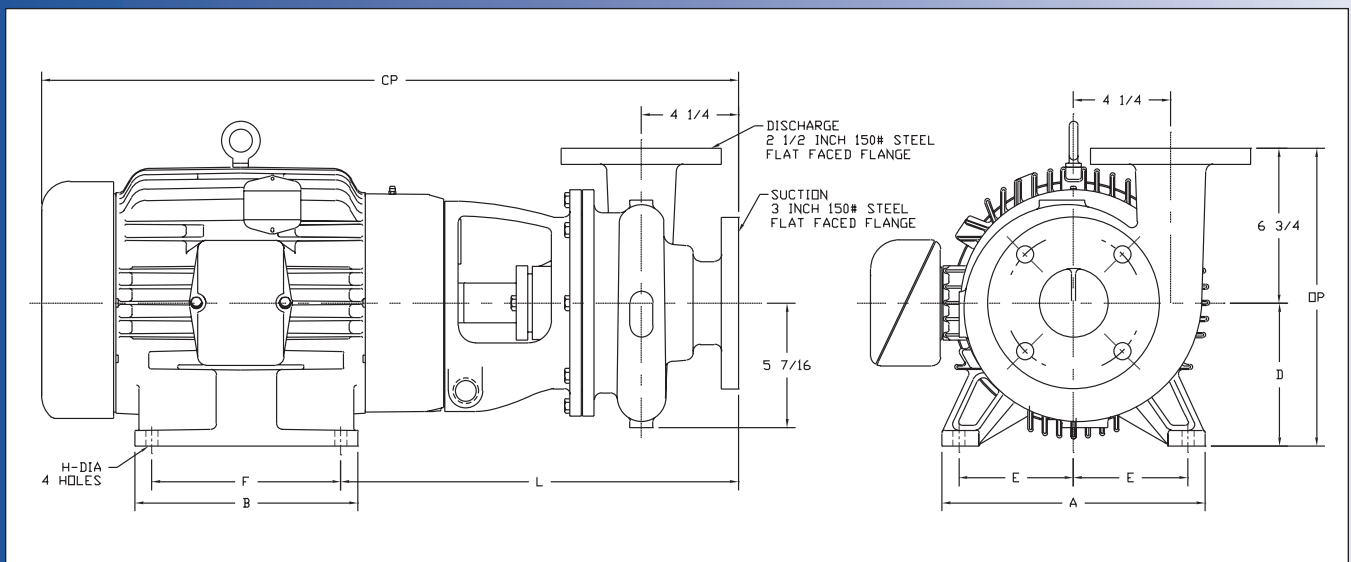
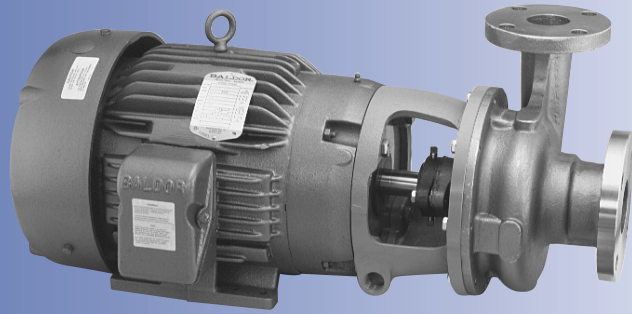

TEFC MOTOR			DIMENSIONS IN INCHES (For Reference Only)										APPROX. WEIGHT (LBS)
HP	RPM	FRAME	A (typ)	B (typ)	D	E	F	H	L	CP	OP		
3	1750	182TCZ	8-5/8	6-1/2	4-1/2	3-3/4	4-1/2	13/32	15-7/16	25-3/4	11-1/4	216	
5	3500	184TCZ	8-5/8	6-1/2	4-1/2	3-3/4	5-1/2	13/32	15-7/16	25-3/4	11-1/4	224	
7-1/2	3500	213JP	9-1/2	8	5-1/4	4-1/4	5-1/2	13/32	17-1/8	28-3/16	12	258	
10	3500	215JP	9-1/2	8	5-1/4	4-1/4	7	13/32	17-1/8	28-3/16	12	276	
15	3500	254JP	11-1/2	9-3/4	6-1/4	5	8-1/4	17/32	17-3/8	30-15/16	13	378	
20	3500	256JP	11-1/2	11-1/2	6-1/4	5	10	17/32	17-3/8	32-1/4	13	416	
25	3500	284JP	12-3/4	12-3/4	7	5-1/2	9-1/2	17/32	17-3/8	35-13/16	13-3/4	516	

## MATERIAL SPECIFICATIONS

PART NAME	NICKEL ALUMINUM BRONZE	STAINLESS STEEL
Casing, Cover & Impeller	AMPCO® 483	316 Stainless
Wear Ring	AMPCO® 18	316 Stainless
Motor Shaft	Steel	Steel
Shaft Sleeve	AMPCO® 18	316 Stainless
Adapter	Cast Iron	Cast Iron

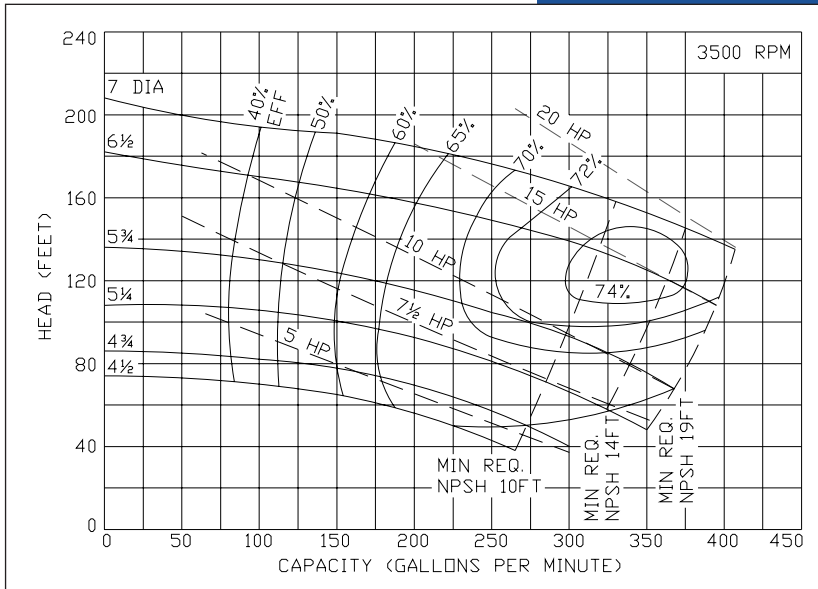

# Ampco Centrifugal Pumps

## MODEL EC/ECH 3 X 2 1/2

Curves show approximate characteristics based on clear 68° water. Rated point is guaranteed.

E Series pumps provide the same heavy-duty construction and hydraulic performance as Ampco's Z Series.

An enlarged stuffing box offers multiple sealing arrangements, including Type 21, Type 1, Type 9, Double Type 21, Double Type 9, packing and cartridge seals.

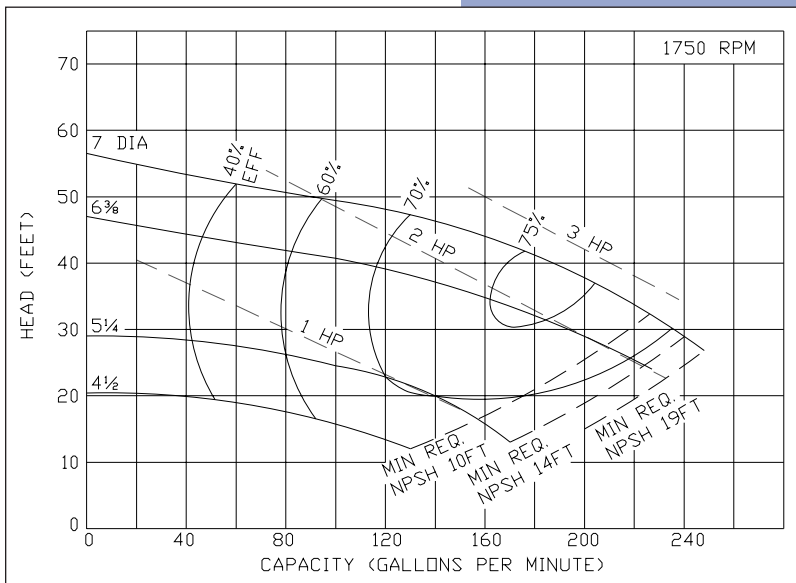
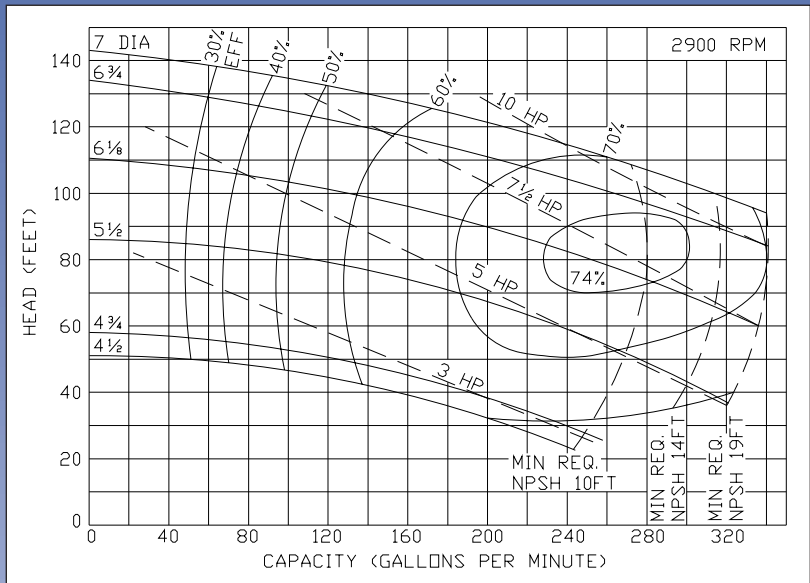

# Ampco Pumps Company

4424 West Mitchell Street  
 Milwaukee, Wisconsin 53214  
 PHONE (414) 643-1852  
 FAX (414) 643-4452

# Ampco Centrifugal Pumps

DATA SHEET

MODEL EC/ECH 4x3

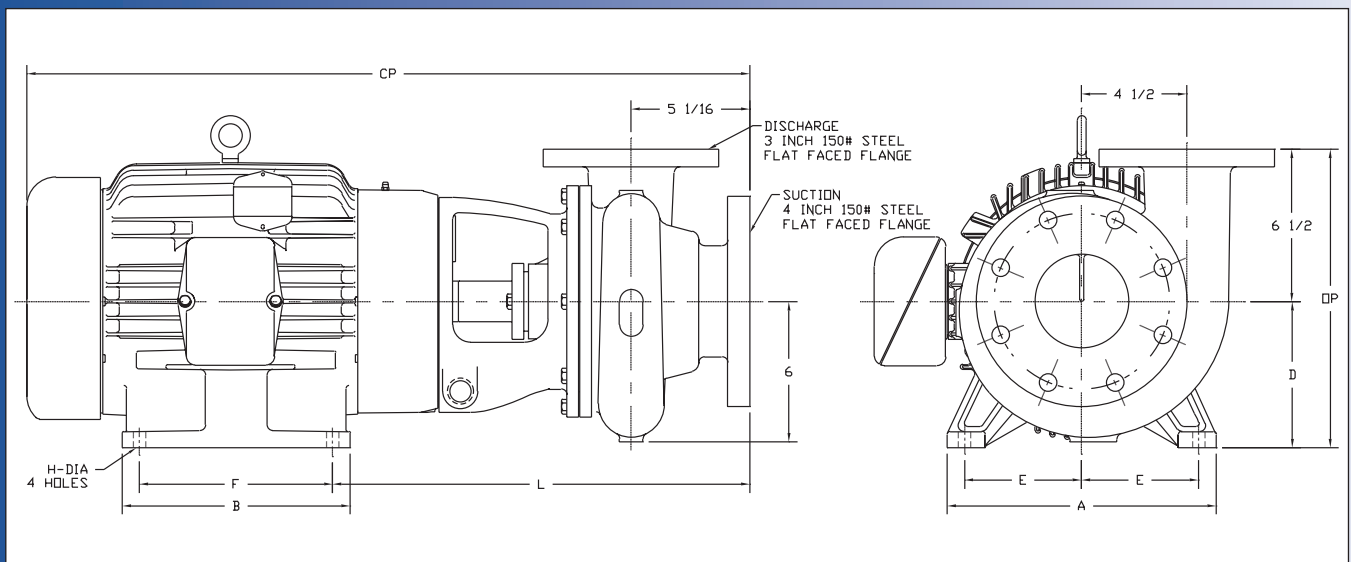
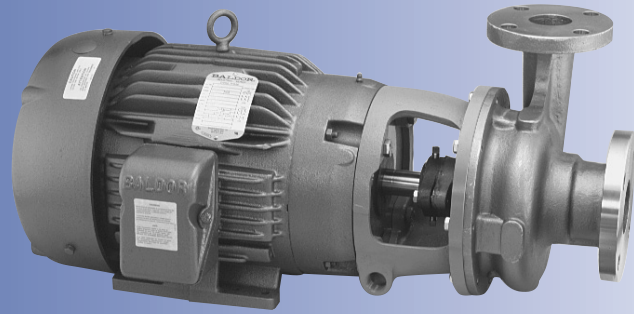

TEFC MOTOR			DIMENSIONS IN INCHES (For Reference Only)									APPROX. WEIGHT (LBS)
HP	RPM	FRAME	A (typ)	B (typ)	D	E	F	H	L	CP	OP	
10	3500	215JP	9-1/2	8	5-1/4	4-1/4	7	13/32	17-9/16	28-5/8	11-3/4	295
15	3500	254JP	11-1/2	9-3/4	6-1/4	5	8-1/4	17/32	17-13/16	30-1/4	12-3/4	403
20	3500	256JP	11-1/2	11-1/2	6-1/4	5	10	17/32	17-13/16	32-11/16	12-3/4	441
25	3500	284JP	12-3/4	12-3/4	7	5-1/2	9-1/2	17/32	17-13/16	36-1/4	13-1/2	572
30	3500	286JP	12-3/4	12-3/4	7	5-1/2	11	17/32	17-13/16	36-1/4	13-1/2	701
3	1750	182TCZ	8-5/8	6-1/2	4-1/2	3-3/4	4-1/2	13/32	16-1/4	26-9/16	11	209
5	1750	184TCZ	8-5/8	6-1/2	4-1/2	3-3/4	5-1/2	13/32	16-1/4	26-9/16	11	237

## MATERIAL SPECIFICATIONS

PART NAME	NICKEL ALUMINUM BRONZE	STAINLESS STEEL
Casing, Cover & Impeller	AMPCO® 483	316 Stainless
Wear Ring	AMPCO® 18	316 Stainless
Motor Shaft	Steel	Steel
Shaft Sleeve	AMPCO® 18	316 Stainless
Adapter	Cast Iron	Cast Iron

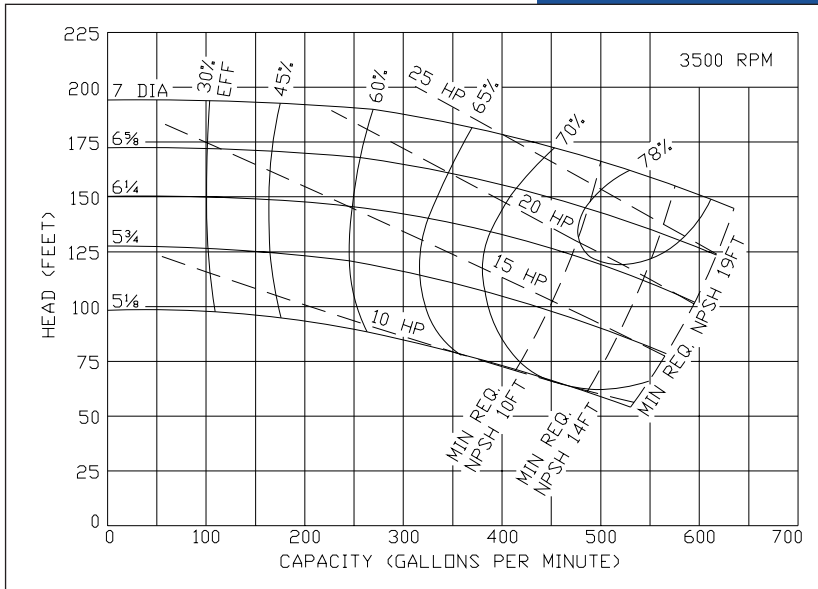

# Ampco Centrifugal Pumps

## MODEL EC/ECH 4 X 3

Curves show approximate characteristics based on clear 68° water. Rated point is guaranteed.

E Series pumps provide the same heavy-duty construction and hydraulic performance as Ampco's Z Series.

An enlarged stuffing box offers multiple sealing arrangements, including Type 21, Type 1, Type 9, Double Type 21, Double Type 9, packing and cartridge seals.

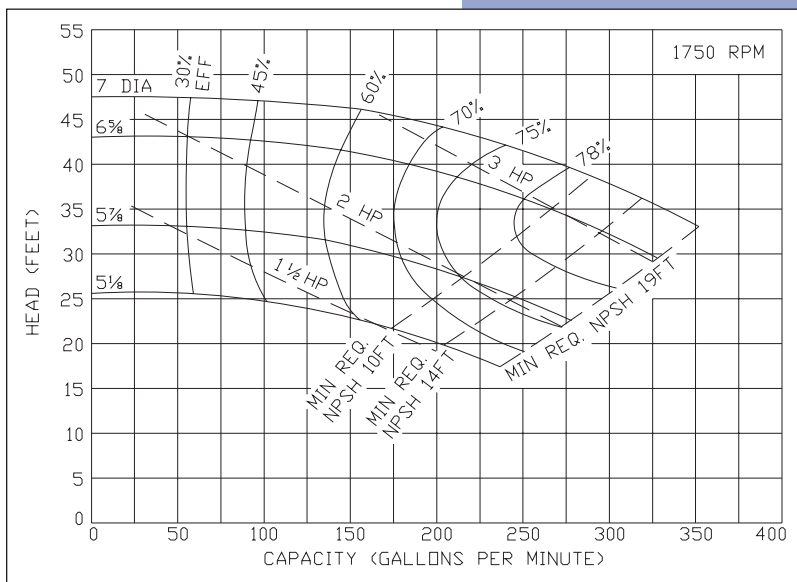
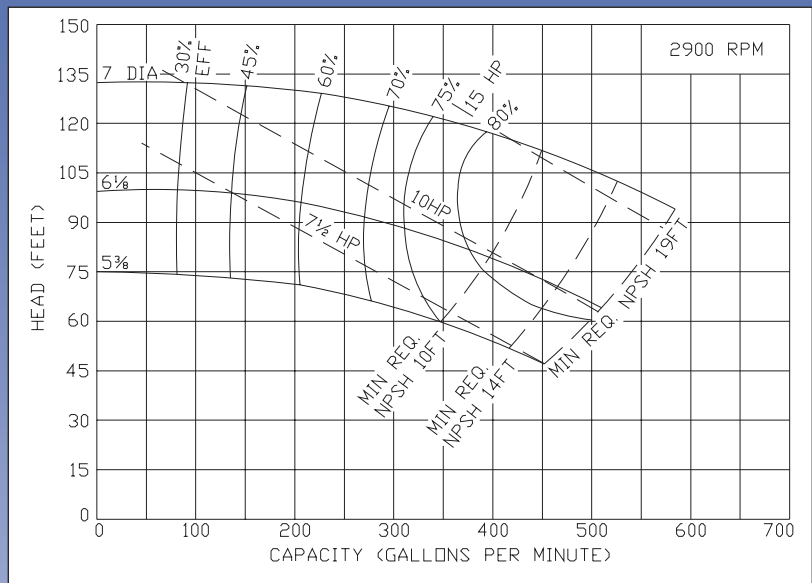

# Ampco Pumps Company

4424 West Mitchell Street  
 Milwaukee, Wisconsin 53214  
 PHONE (414) 643-1852  
 FAX (414) 643-4452



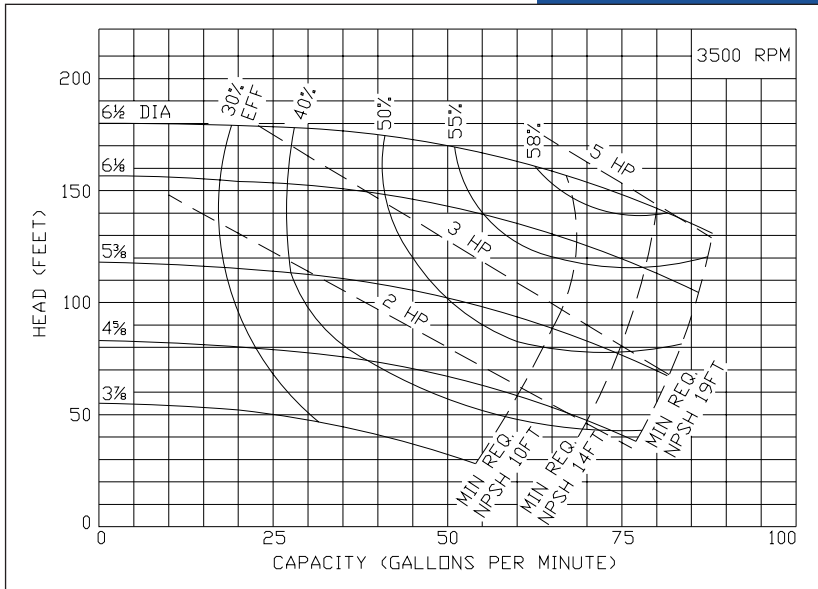

# Ampco Centrifugal Pumps

**MODEL EP 1 1/2 X 1 1/4  
NICKEL ALUMINUM BRONZE**

Curves show approximate characteristics based on clear 68° water. Rated point is guaranteed.

E Series pumps provide the same heavy-duty construction and hydraulic performance as Ampco's Z Series.

An enlarged stuffing box offers multiple sealing arrangements, including Type 21, Type 1, Type 9, Double Type 21, Double Type 9, packing and cartridge seals.

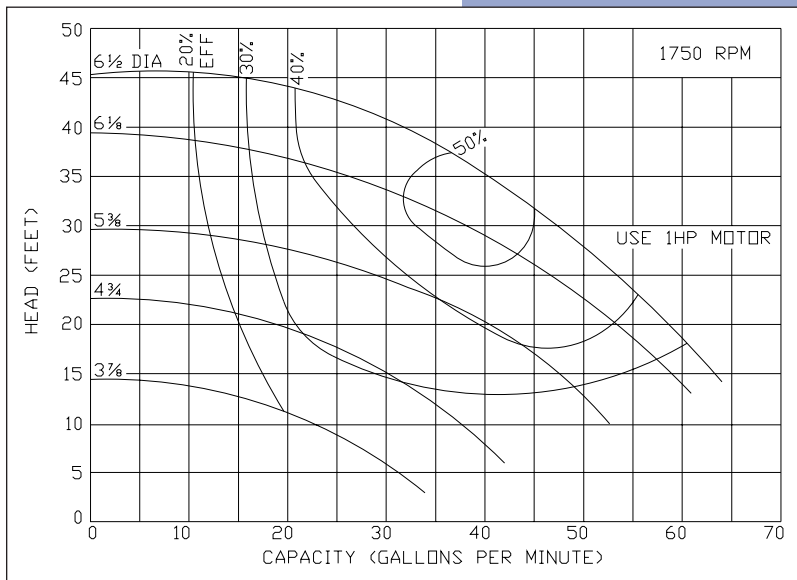
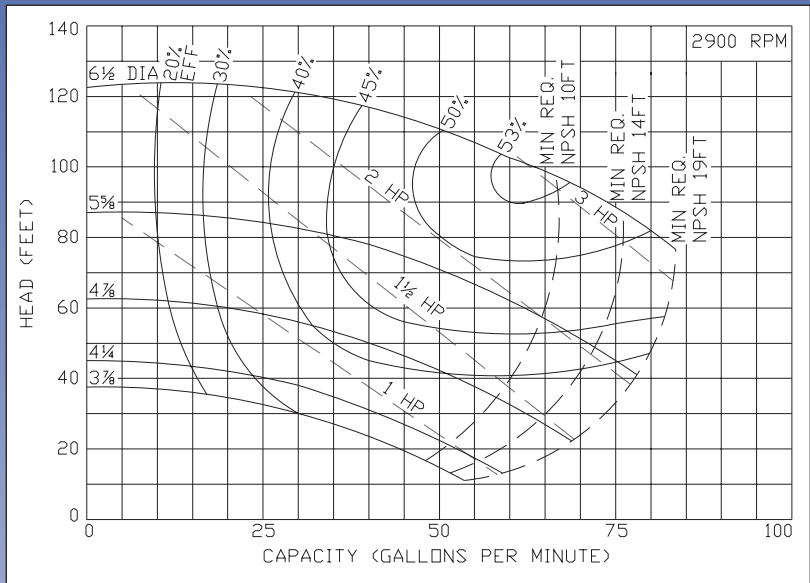

# Ampco Pumps Company

4424 West Mitchell Street  
Milwaukee, Wisconsin 53214  
PHONE (414) 643-1852  
FAX (414) 643-4452

# Ampco Centrifugal Pumps

## DATA SHEET

MODEL EP 1 1/2 X 1 1/4  
STAINLESS STEEL

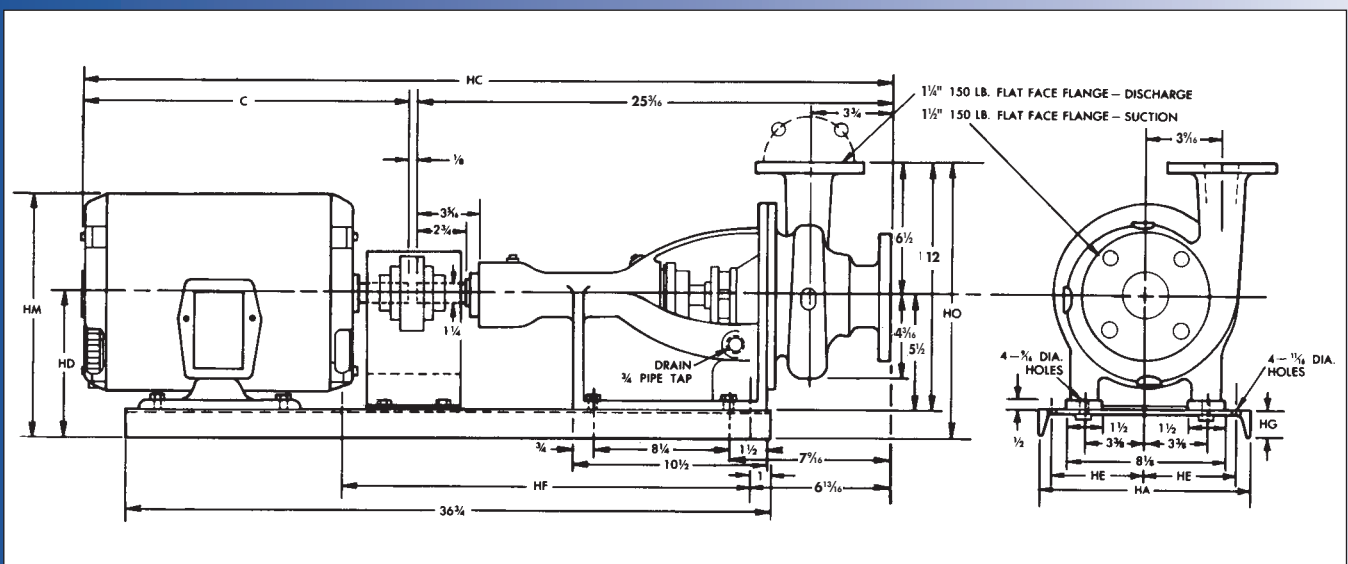
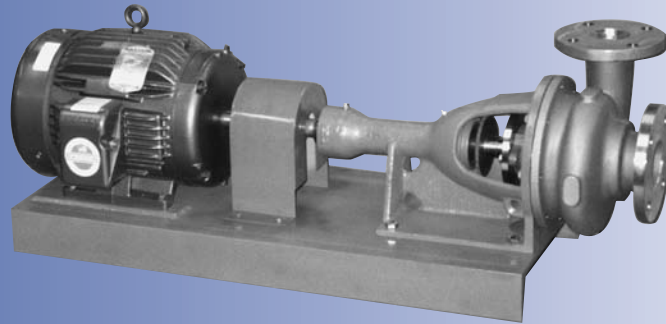

TEFC MOTOR			DIMENSIONS IN INCHES (For Reference Only)					
HP	RPM	FRAME	HA	HD	HE	HF	HG	HO
1	1750	143T	12	8-1/2	4-3/4	33-3/8	3	15
2	3500	145T	12	8-1/2	4-3/4	33-3/8	3	15
3	3500	182T	15	8-7/8	5-3/4	19	3-3/8	15-3/8
5	3500	184T	15	8-7/8	5-3/4	19	3-3/8	15-3/8
7-1/2	3500	213T	15	8-7/8	5-3/4	19	3-3/8	15-3/8

## MATERIAL SPECIFICATIONS

PART NAME	STAINLESS STEEL
Casing, Cover & Impeller	316 Stainless
Wear Ring	316 Stainless
Shaft	Steel
Shaft Sleeve	316 Stainless
Frame	Cast Iron

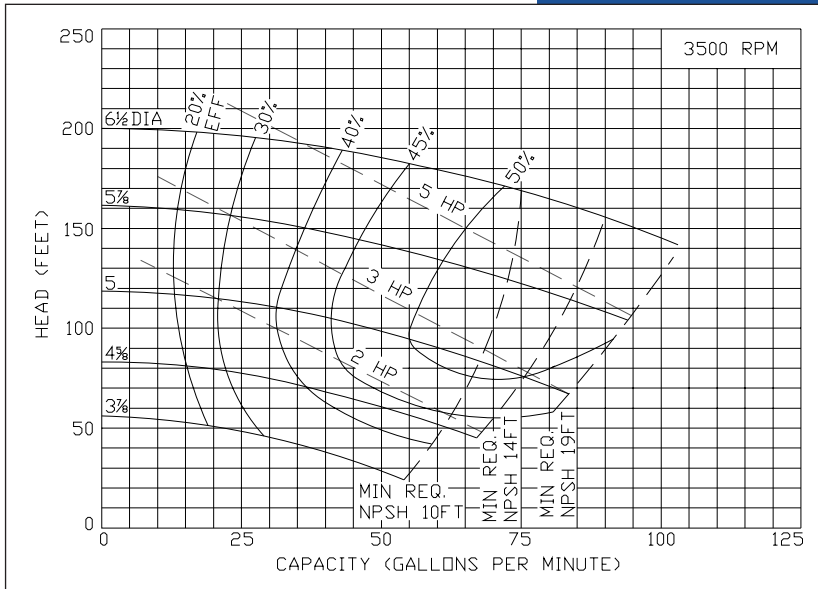

# Ampco Centrifugal Pumps

**MODEL EP 1 1/2 X 1 1/4**  
STAINLESS STEEL

Curves show approximate characteristics based on clear 68° water. Rated point is guaranteed.

E Series pumps provide the same heavy-duty construction and hydraulic performance as Ampco's Z Series.

An enlarged stuffing box offers multiple sealing arrangements, including Type 21, Type 1, Type 9, Double Type 21, Double Type 9, packing and cartridge seals.

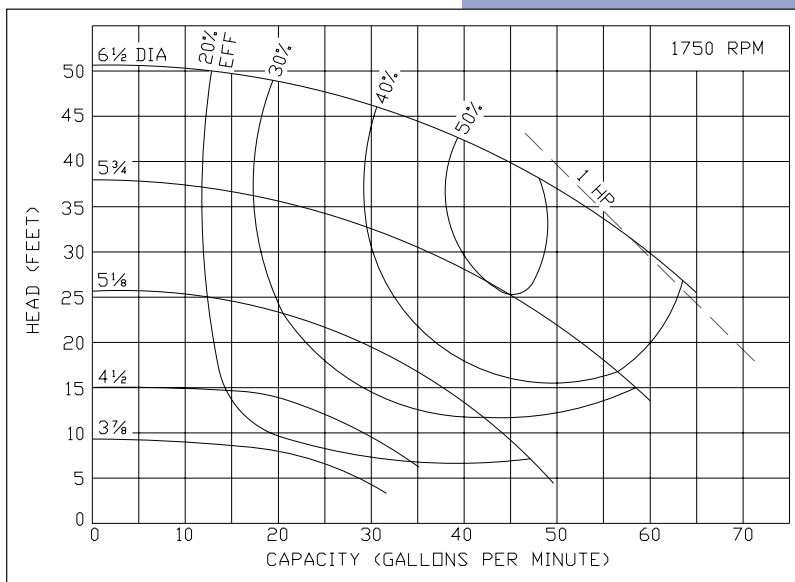
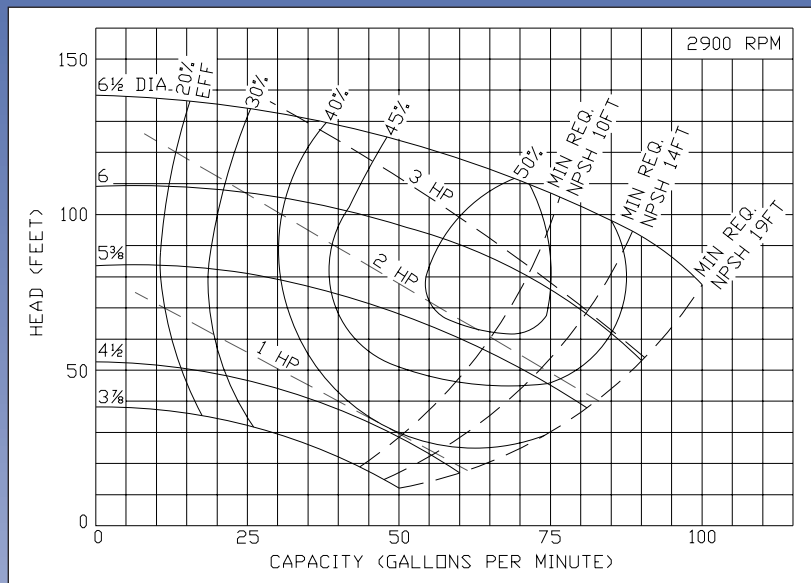

# Ampco Pumps Company

4424 West Mitchell Street  
Milwaukee, Wisconsin 53214  
PHONE (414) 643-1852  
FAX (414) 643-4452



# Ampco Centrifugal Pumps

DATA SHEET

MODEL EP 2 X 1 $\frac{1}{2}$

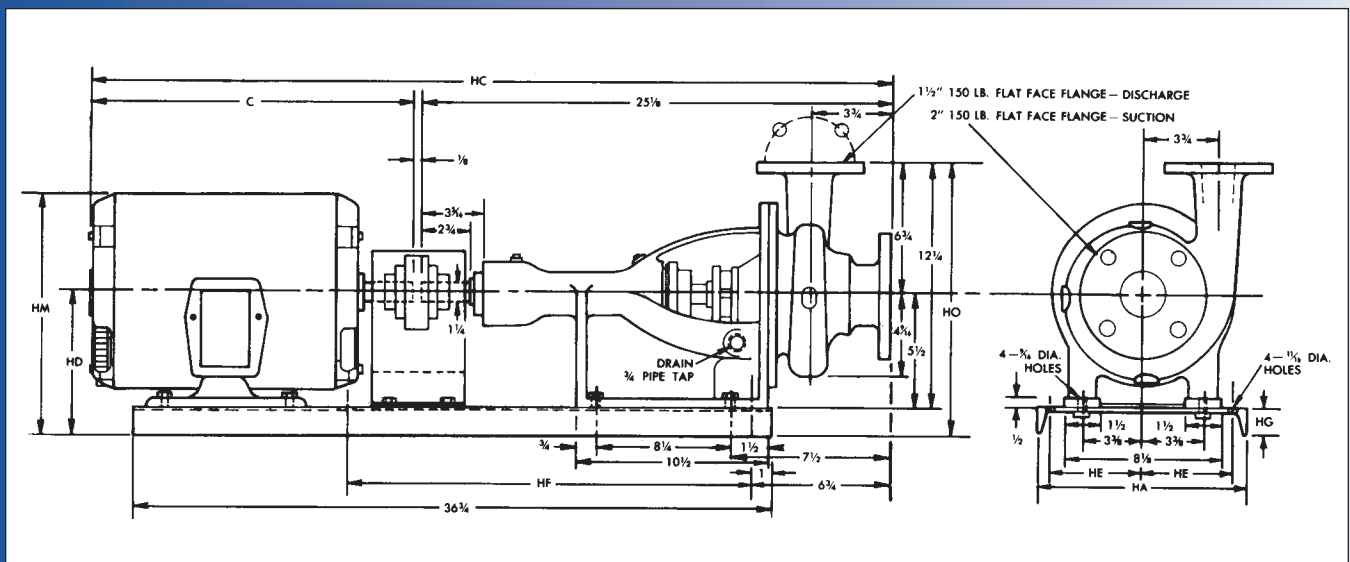
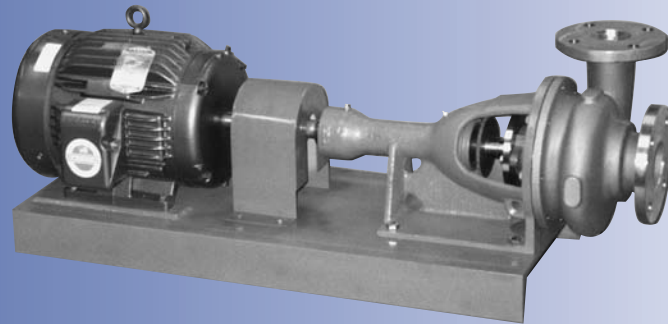

TEFC MOTOR			DIMENSIONS IN INCHES (For Reference Only)					
HP	RPM	FRAME	HA	HD	HE	HF	HG	HO
1	1750	143T	12	8-1/2	4-3/4	33-3/8	3	15-1/4
2	3500	145T	12	8-1/2	4-3/4	33-3/8	3	15-1/4
3	3500	182T	15	8-7/8	5-3/4	19	3-3/8	15-5/8
5	3500	184T	15	8-7/8	5-3/4	19	3-3/8	15-5/8
7-1/2	3500	213T	15	8-7/8	5-3/4	19	3-3/8	15-5/8

## MATERIAL SPECIFICATIONS

PART NAME	NICKEL ALUMINUM BRONZE	STAINLESS STEEL
Casing, Cover & Impeller	AMPCO® 483	316 Stainless
Wear Ring	AMPCO® 18	316 Stainless
Shaft	Steel	Steel
Shaft Sleeve	AMPCO® 18	316 Stainless
Frame	Cast Iron	Cast Iron

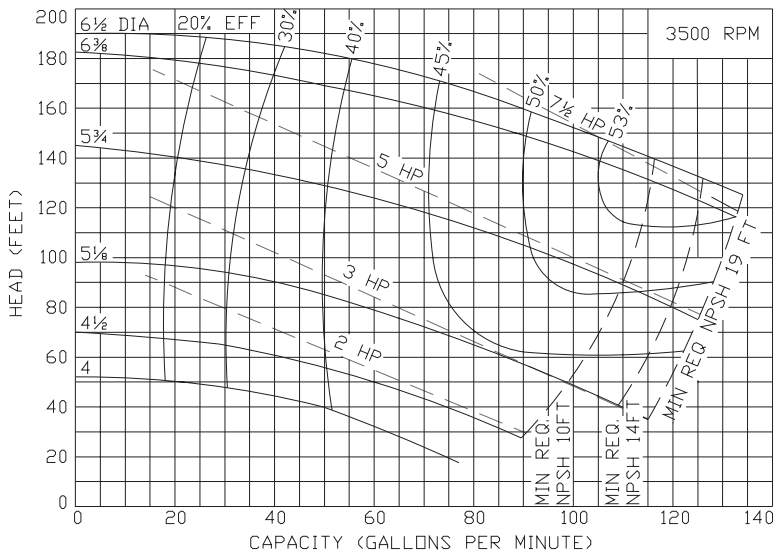

# Ampco Centrifugal Pumps

## MODEL EP 2 X 1 1/2

Curves show approximate characteristics based on clear 68° water. Rated point is guaranteed.

E Series pumps provide the same heavy-duty construction and hydraulic performance as Ampco's Z Series.

An enlarged stuffing box offers multiple sealing arrangements, including Type 21, Type 1, Type 9, Double Type 21, Double Type 9, packing and cartridge seals.

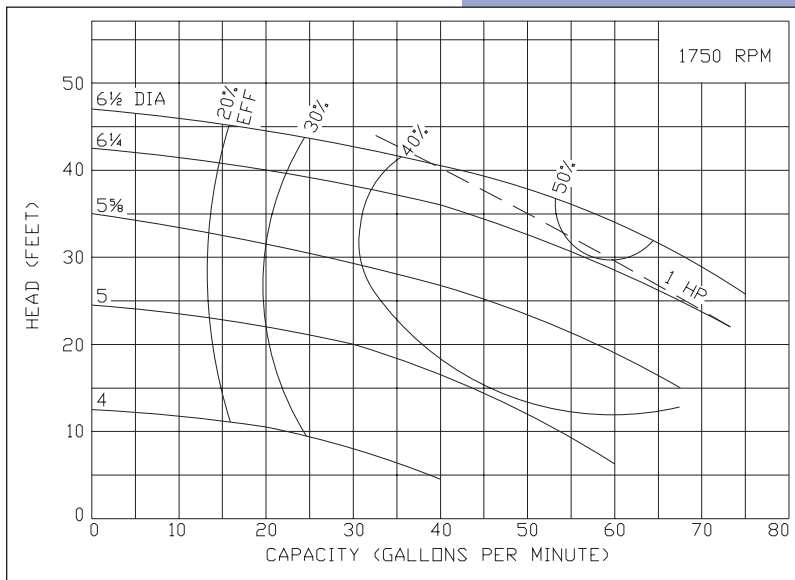
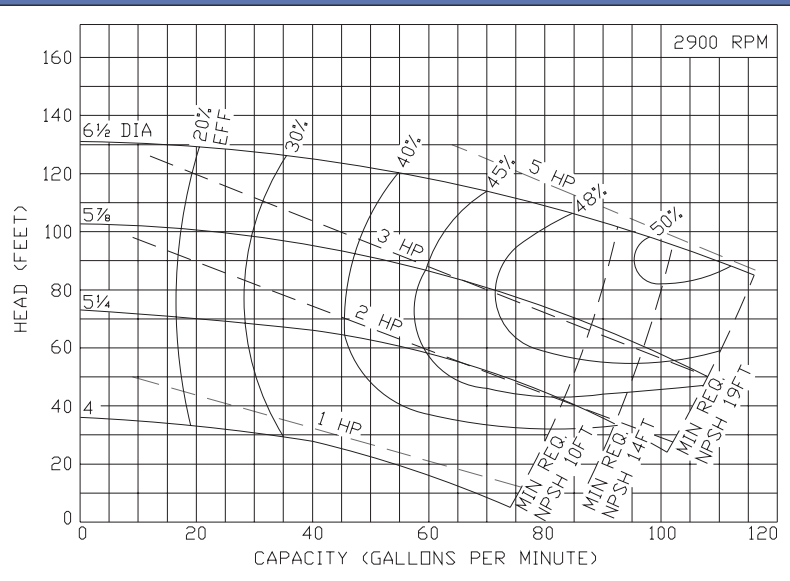

# Ampco Pumps Company

4424 West Mitchell Street  
 Milwaukee, Wisconsin 53214  
 PHONE (414) 643-1852  
 FAX (414) 643-4452



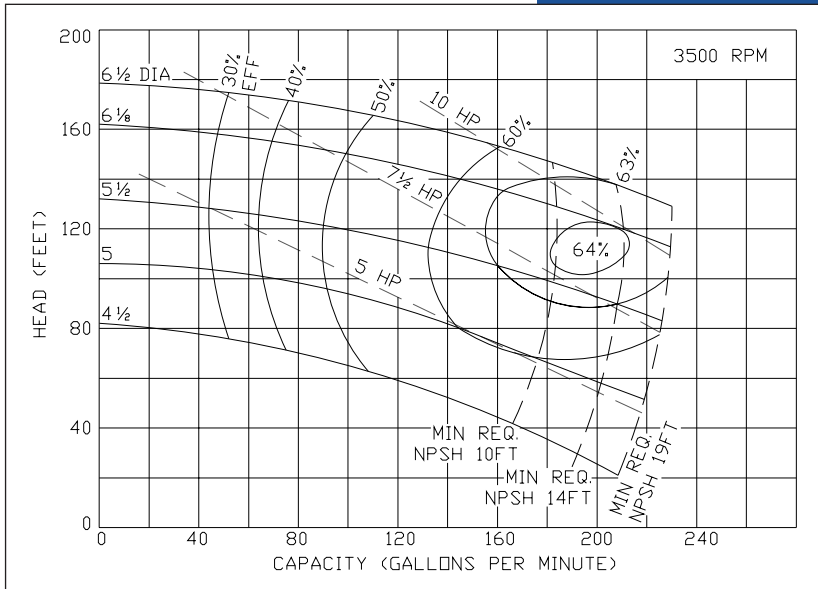

# Ampco Centrifugal Pumps

## MODEL EP 2 1/2 X 2

Curves show approximate characteristics based on clear 68° water. Rated point is guaranteed.

E Series pumps provide the same heavy-duty construction and hydraulic performance as Ampco's Z Series.

An enlarged stuffing box offers multiple sealing arrangements, including Type 21, Type 1, Type 9, Double Type 21, Double Type 9, packing and cartridge seals.

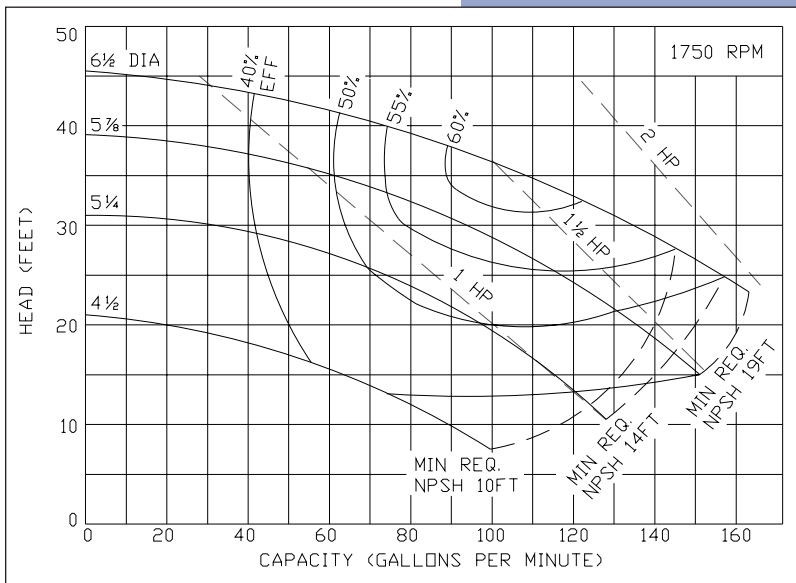
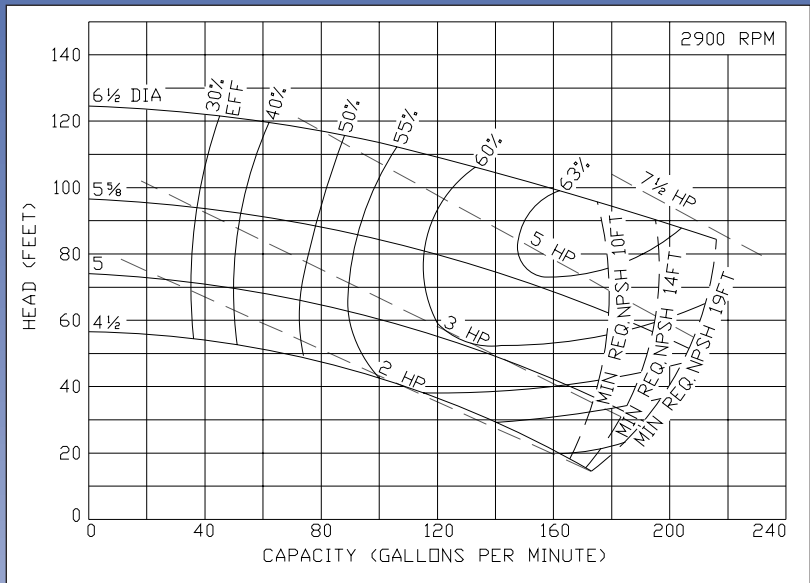

# Ampco Pumps Company

4424 West Mitchell Street  
 Milwaukee, Wisconsin 53214  
 PHONE (414) 643-1852  
 FAX (414) 643-4452

# Ampco Centrifugal Pumps

DATA SHEET

MODEL EP/EPH 3 X 2 1/2

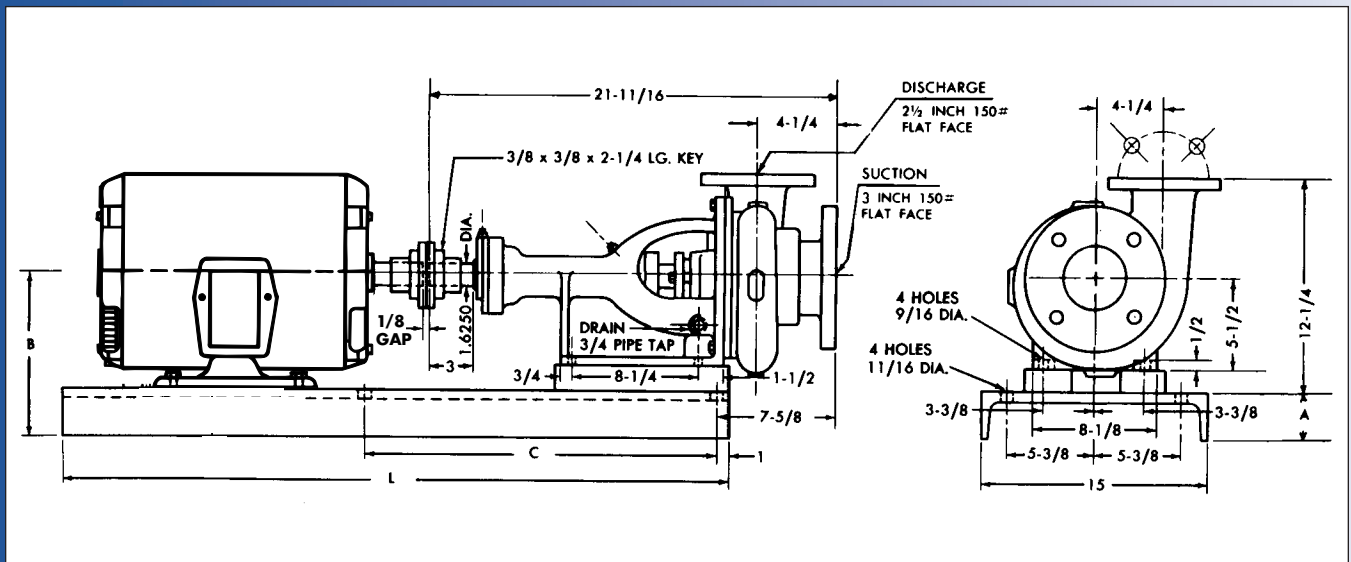
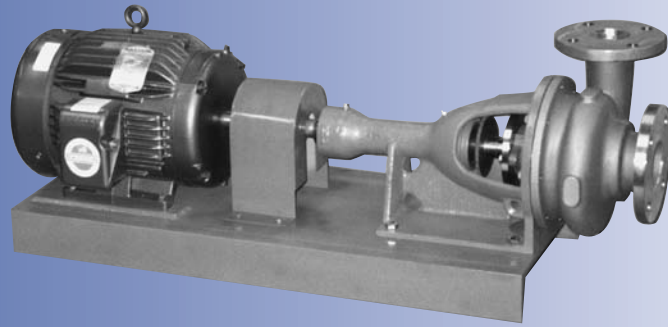

TEFC MOTOR			DIMENSIONS IN INCHES (For Reference Only)			
HP	RPM	FRAME	A	B	C	L
7-1/2	3500	213T	3-7/8	9-3/8	19	36-3/4
10	3500	215T	3-7/8	9-3/8	19	36-3/4
15	3500	254T	4-1/8	9-5/8	23	41-1/2
20	3500	256T	4-1/8	9-5/8	23	41-1/2
25	3500	284T	4-7/8	10-3/8	23	45-1/2

## MATERIAL SPECIFICATIONS

PART NAME	NICKEL ALUMINUM BRONZE	STAINLESS STEEL
Casing, Cover & Impeller	AMPCO® 483	316 Stainless
Wear Ring	AMPCO® 18	316 Stainless
Shaft	Steel	Steel
Shaft Sleeve	AMPCO® 18	316 Stainless
Frame	Cast Iron	Cast Iron

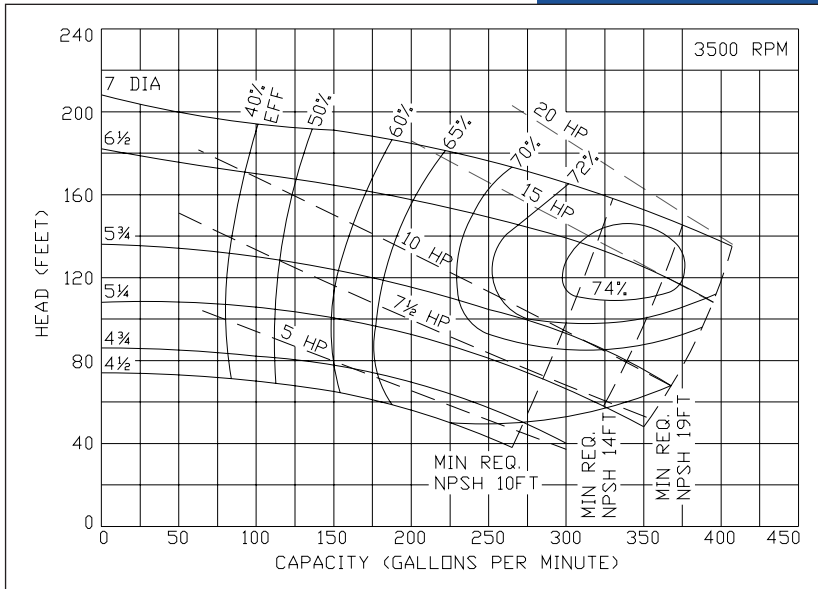

# Ampco Centrifugal Pumps

## MODEL EP/EPH 3 X 2 1/2

Curves show approximate characteristics based on clear 68° water. Rated point is guaranteed.

E Series pumps provide the same heavy-duty construction and hydraulic performance as Ampco's Z Series.

An enlarged stuffing box offers multiple sealing arrangements, including Type 21, Type 1, Type 9, Double Type 21, Double Type 9, packing and cartridge seals.

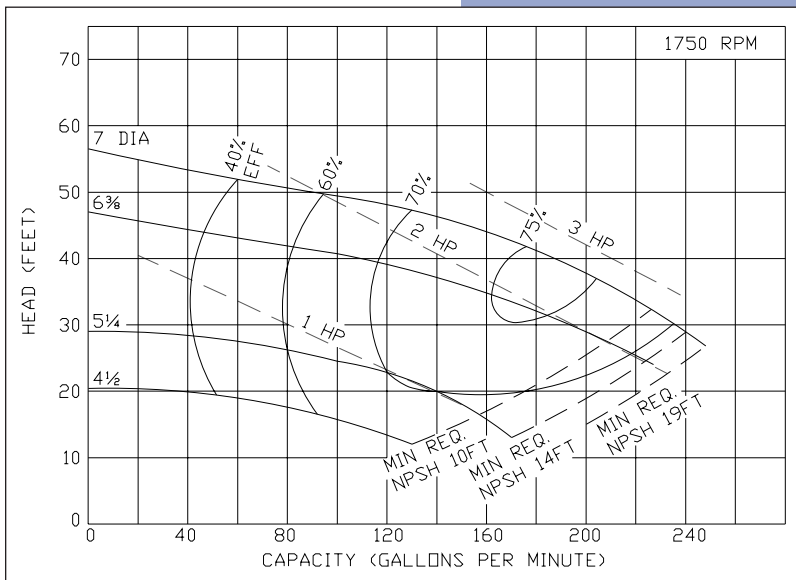
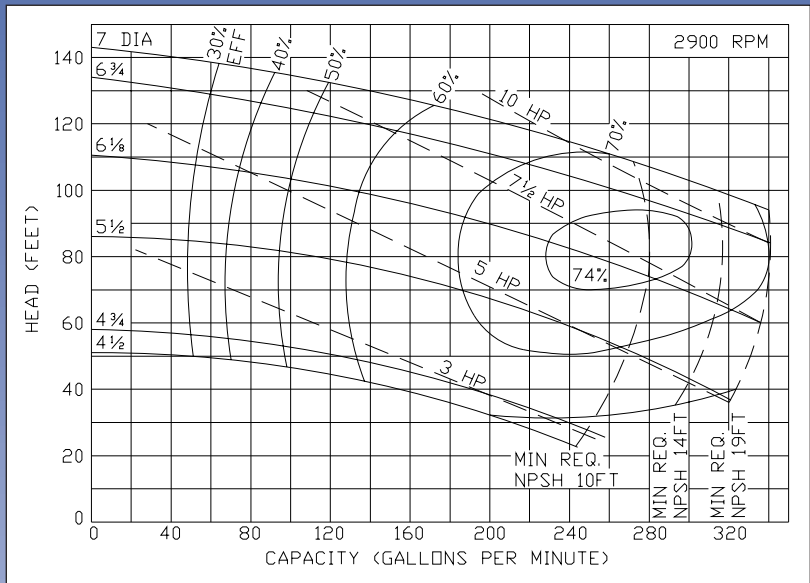

# Ampco Pumps Company

4424 West Mitchell Street  
 Milwaukee, Wisconsin 53214  
 PHONE (414) 643-1852  
 FAX (414) 643-4452

# Ampco Centrifugal Pumps

DATA SHEET

MODEL EP/EPH 4X3

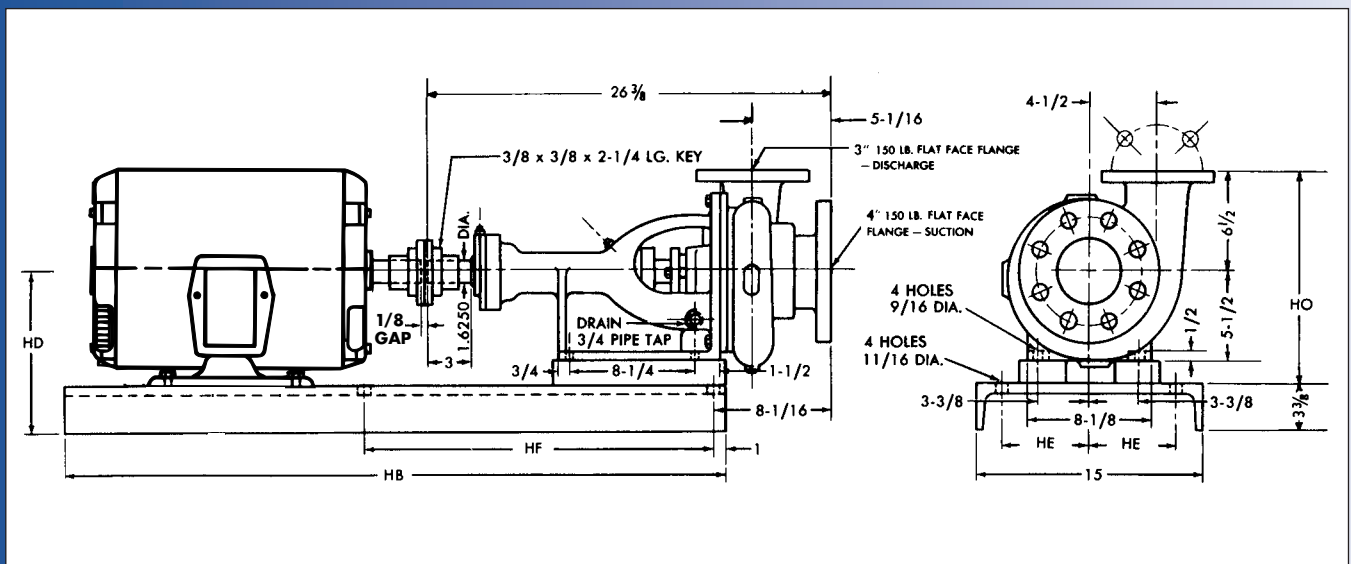
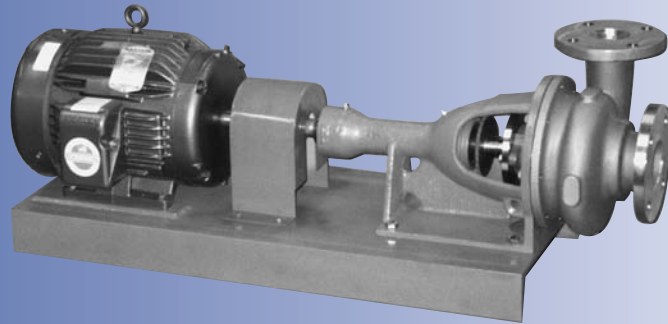

TEFC MOTOR			DIMENSIONS IN INCHES (For Reference Only)				
HP	RPM	FRAME	HB	HD	HE	HF	HO
10	3500	215T	36-3/4	8-7/8	6	19	15-3/8
15	3500	254T	41-1/2	9-5/8	6	23	16-1/8
20	3500	256T	41-1/2	9-5/8	6	23	16-1/8
25	3500	284TS	41-1/2	10-3/8	5-3/4	23	16-7/8
30	3500	286TS	41-1/2	10-3/8	5-3/4	23	16-7/8

## MATERIAL SPECIFICATIONS

PART NAME	NICKEL ALUMINUM BRONZE	STAINLESS STEEL
Casing, Cover & Impeller	AMPCO® 483	316 Stainless
Wear Ring	AMPCO® 18	316 Stainless
Shaft	Steel	Steel
Shaft Sleeve	AMPCO® 18	316 Stainless
Frame	Cast Iron	Cast Iron

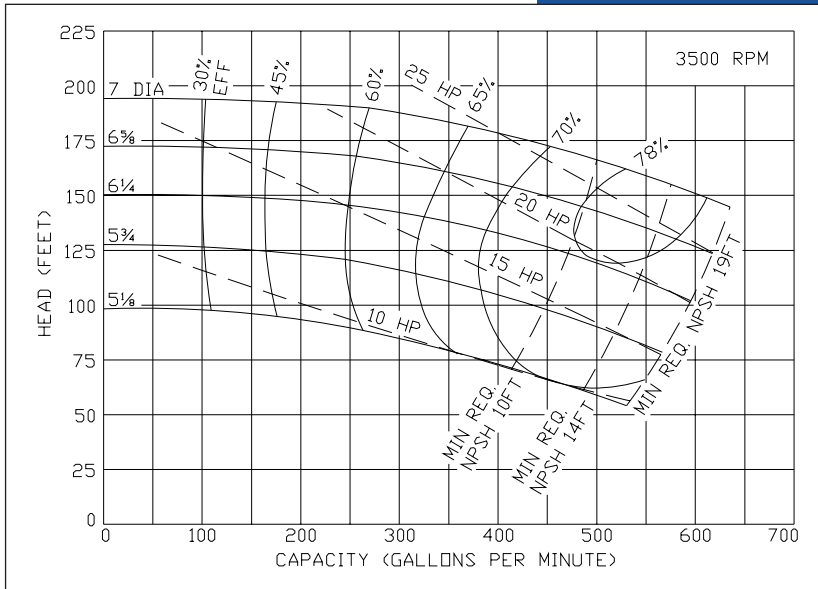

# Ampco Centrifugal Pumps

## MODEL EP/EPH 4x3

Curves show approximate characteristics based on clear 68° water. Rated point is guaranteed.

E Series pumps provide the same heavy-duty construction and hydraulic performance as Ampco's Z Series.

An enlarged stuffing box offers multiple sealing arrangements, including Type 21, Type 1, Type 9, Double Type 21, Double Type 9, packing and cartridge seals.

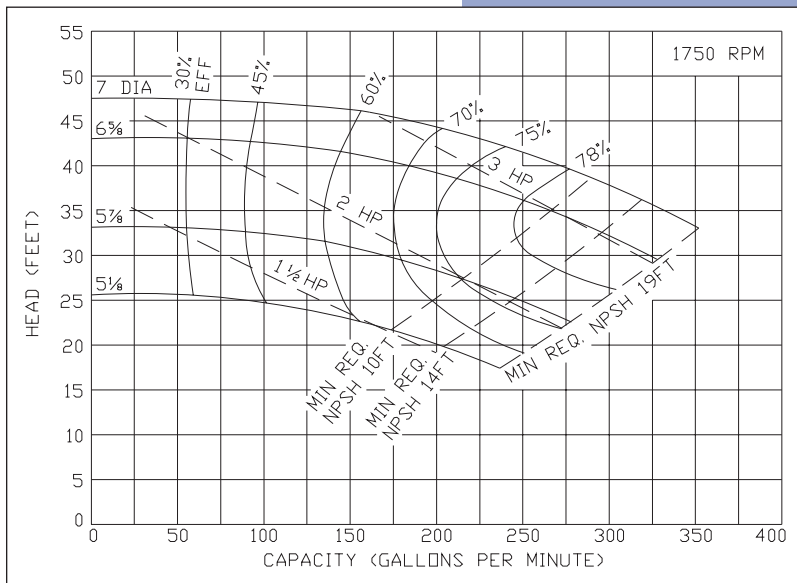
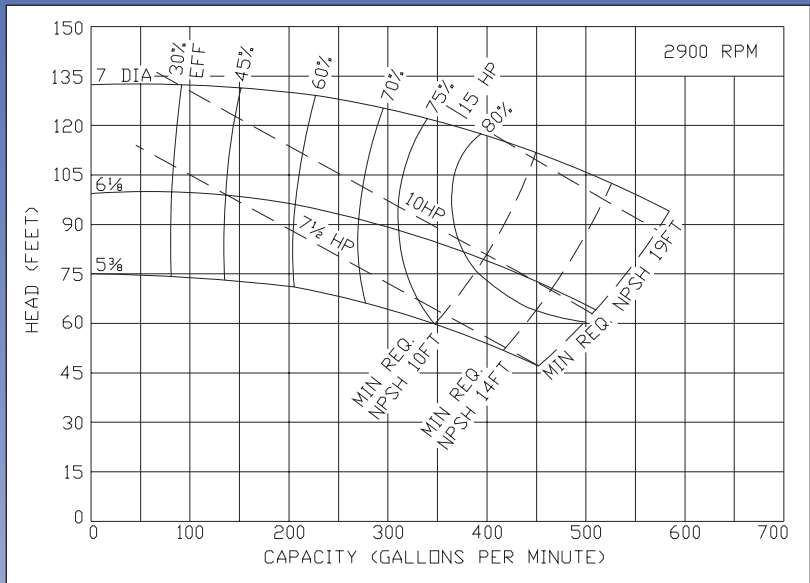

# Ampco Pumps Company

4424 West Mitchell Street  
 Milwaukee, Wisconsin 53214  
 PHONE (414) 643-1852  
 FAX (414) 643-4452