

**M E T A L M A G <sup>TM</sup> L I N E**

# **ULTRACHem<sup>®</sup> Series**

**A N S I D I M E N S I O N A L M A G D R I V E**

**UC436, UC438, UC328, & UC3158 Models**

## **OPERATIONAL MANUAL**

**Record your Model and Serial Number here.**

**MODEL NUMBER** \_\_\_\_\_

**SERIAL NUMBER** \_\_\_\_\_

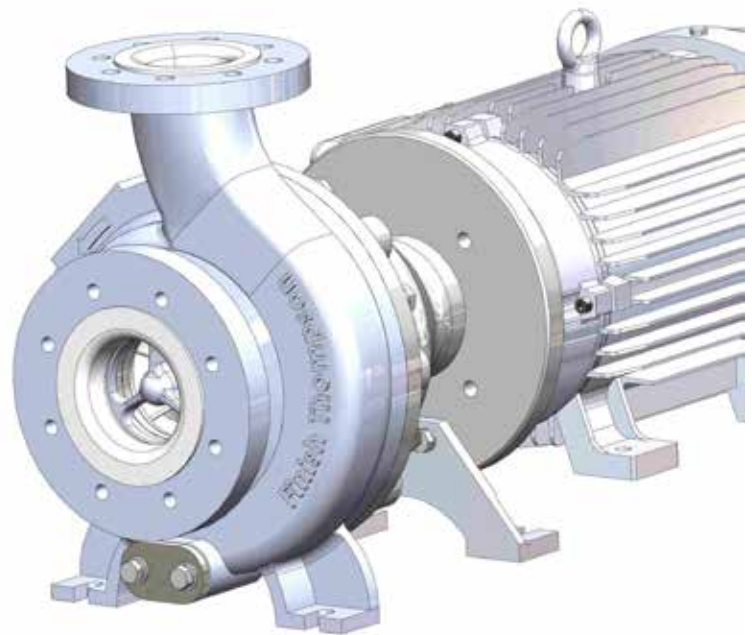

**FINISH THOMPSON INC.**

# Table of Contents

Warranty Statement .....	3	
Safety Precautions .....	3	
ULTRAChem Features .....	4	
ULTRAChem Capabilities.....	4	
Surface Temperature for ATEX Pumps .....	4	
Maximum Allowable Horsepower.....	4	
Minimum Allowable Flow Rate .....	5	
Model Codes and Abbreviations.....	5	
Unpacking and Inspection.....	6	
Model Number and Serial Number.....	6	
<b>Installation</b>		
Pumps with Motors .....	6	
Pumps without Motors .....	6-7	
Foundation .....	8	
Baseplate .....	8	
Piping.....	8-9	
Electrical .....	9	
<b>Operation</b>		
Pre-operation Inspection.....	9	
Start-up and Operation.....	9-10	
Shutdown.....	10	
<b>Disassembly/Reassembly</b>		
Disassembly of Pump End .....	10-11	
Disassembly of Power End (Motor Side) .....	11	
Examination .....	12	
Replacing Wear Components .....	13	
Shaft Support/Front Thrust Washer .....	13	
Impeller Thrust Ring .....	13	
Rear Sealing Ring .....	14	
Impeller Assembly Removal and Replacement.....	14	
Impeller Bushings.....	15	
Power End Reassembly .....	15	
Pump End Reassembly .....	15-16	
Troubleshooting .....	17	
General Notes		
Important Notice .....	17	
Chemical Reaction Disclaimer.....	17	
Helpful Hints .....	17	
Ordering Spare Parts .....	17	
Exploded View Drawing .....		18
Parts List .....	19-22	

## WARRANTY

Finish Thompson, Inc. (manufacturer) warrants this pump product to be free of defects in materials and workmanship for a period of two years from date of purchase by original purchaser. If a warranted defect, which is determined by manufacturer's inspection, occurs within this period, it will be repaired or replaced at the manufacturer's option, provided (1) the product is submitted with proof of purchase date and (2) transportation charges are prepaid to the manufacturer. Liability under this warranty is expressly limited to repairing or replacing the product or parts thereof and is in lieu of any other warranties, either expressed or implied. This warranty does apply only to normal wear of the product or components. This warranty does not apply to products or parts broken due to, in whole or in part, accident, overload, abuse, chemical attack, tampering, or alteration. The warranty does not apply to any other equipment used or purchased in combination with this product. The manufacturer accepts no responsibility for product damage or personal injuries sustained when the product is modified in any way. If this warranty does not apply, the purchaser shall bear all cost for labor, material and transportation.

Manufacturer shall not be liable for incidental or consequential damages including, but not limited to process down time, transportation costs, costs associated with replacement or substitution products, labor costs, product installation or removal costs, or loss of profit. In any and all events, manufacturer's liability shall not exceed the purchase price of the product and/or accessories.

## SAFETY PRECAUTIONS

- ⚠ WARNING:** READ THIS MANUAL COMPLETELY BEFORE INSTALLING AND OPERATING THIS UNIT. FAILURE TO FOLLOW THESE PRECAUTIONS CAN RESULT IN SERIOUS INJURY OR DEATH.
- ⚠ WARNING:** Magnetic force hazard. This pump should only be disassembled and assembled using the recommended procedures. The magnetic attraction is powerful enough to rapidly pull the motor end and the wet end together. ALWAYS use the jackscrews (item 14) to assemble/disassemble the pump. Do not place fingers between the mating surfaces of the motor and wet ends to avoid injuries. Keep the drive magnet and impeller assembly away from metal chips or particles.
- ⚠ WARNING:** Magnetic Field Hazard. This pump contains powerful rare earth magnets. When the pump is disassembled (not connected to a motor) and the magnets are exposed, these magnets produce powerful magnetic fields. Individuals with cardiac pacemakers, implanted defibrillators, other electronic medical devices, metallic prosthetic heart valves, internal wound clips (from surgery), metallic prosthetic devices or sickle cell anemia must not handle or be in the proximity of the magnets contained inside the pump. Consult a health care provider for specific recommendations before working with this pump.
- ⚠ WARNING:** Hot surfaces. This pump is capable of handling liquids with temperatures as high as 250° F. This may cause the outer areas of the pump to become hot as well and could cause burns.
- ⚠ WARNING:** Check for leaks on a regular basis. If any leaks are found, the pump must be repaired immediately.
- ⚠ WARNING:** Rotating Parts. This pump has components that rotate while in operation. Follow local safety standards for locking out the motor from the power supply during maintenance or service.
- ⚠ WARNING:** Chemical Hazard. This pump is used for transferring many types of potentially dangerous chemicals. *Always* wear protective clothing, eye protection and follow standard safety procedures when handling corrosive or personally harmful materials. Proper procedures should be followed for draining and decontaminating the pump before disassembly and inspection of the pump. There may be small quantities of chemicals present during inspection.
- ⚠ WARNING:** Never run pump at less than minimum flow or with the discharge valve closed. This could lead to pump failure.
- ⚠ WARNING:** Never operate the pump without safety features installed.
- ⚠ WARNING:** The pump and associated components are heavy. Failure to properly support the pump during lifting and movement could result in serious injury or damage to the pump and components.
- ⚠ CAUTION:** Do not run the pump dry. This pump should never be started without liquid in the casing. This could damage the pump. The fluid being transferred by the pump lubricates the pump components. Even short periods of running the pump dry could damage the pump. It is recommended that run dry protection be used. Optional electronic power monitors are available to help protect against run dry.
- ⚠ CAUTION:** The correct o-ring material must be chosen to ensure compatibility with the fluid being pumped. If the incorrect material is chosen, it can lead to swollen or degrading o-rings that allow leaking. O-ring material selection is the responsibility of the end user.
- ⚠ CAUTION:** Never start or operate with a closed suction valve. Never operate with a closed discharge valve.
- ⚠ CAUTION:** Always provide adequate NPSHa (net positive suction head available).

## ADDITIONAL SAFETY PRECAUTIONS FOR ATEX COMPLIANT PUMPS

- ⚠ WARNING:** ATEX compliant pumps must be cleaned on a regular basis to avoid buildup of explosive dust greater than 5 mm.
- ⚠ WARNING:** ATEX pumps must use a power monitor, flow switch, pressure switch or similar device to help protect against dry running, closed discharge valve and de-coupling. Any of these conditions could lead to a rise in surface temperature of the pump.

## ULTRAChem Features

The Finish Thompson ULTRAChem is a sealless, magnetically driven, ANSI dimensional, ETFE lined chemical pump. It has been specifically designed for corrosive chemical applications in a wide range of industrial services.

The ULTRAChem features a closed impeller, suction straightening vanes, balanced axial thrust with a rear sealing ring, balance holes and balanced radial thrust due to the modified concentric or partial splitter volute shapes.

The ULTRAChem uses standard silicon carbide shaft, thrust bearings and bushings (optional carbon bushings allow limited run dry capabilities). All metallic components are steel or cast ductile iron.

High strength, rare earth neodymium iron boron magnets are used for maximum power and reliability. Finish Thompson's patented magnetic technology ensures an extraordinarily strong, secure coupling between the motor and pump.

The barrier consists of a precision molded carbon filled ETFE liner with an external aramid fabric/epoxy shell for superior mechanical strength and elimination of eddy currents in the magnetic coupling. The sealless design virtually eliminates maintenance and environmental emissions.

The Easy Set drive feature makes installation of the outer drive quick and easy. It eliminates the need for measuring and ensures that the inner and outer magnets are perfectly aligned to transmit maximum power.

The ULTRAChem has drive hubs and motor adapters for a complete range of NEMA and IEC motor frames. The suction and discharge flanges can be drilled to fit ANSI 150#, 300# and ISO PN40 bolting dimensions.

These features combine to provide our customers with a pump that offers a broad operating range with outstanding reliability due to minimum hydraulic loads and premium materials of construction.

FTI's ATEX compliant pumps meet Directive 94/9/EC for use in potentially explosive atmospheres.

## ULTRAChem Capabilities

Maximum Working Pressure:	300 psi (20.7 bar)
Maximum Temperature:	250°F (121° C), (E-magnet up to 220° F (104° C) Application Dependent )
Minimum Temperature:	-20°F (-29° C)
Maximum Flow:	825 US GPM (187 m3/hr)
Maximum Head:	280 ft (85 m)
Maximum Viscosity:	200 cP
Maximum Noise Level:	80 dBA (pump only)
Solids:	Maximum particle size is 50 microns for slurries and 1/64" (.4 mm) for infrequent particles. Maximum hardness is 80 HS. Maximum concentration is 5% by weight. If solids are being pumped, it is recommended the pump have the silicon carbide bushings and thrust washer.

## Surface Temperature for ATEX Pumps

Fluid Temperature	Max. Surface Temperature	Temperature Class	Max. Allowable Surface Temperature
88°F (31°C)	153°F (67°C)	T6	185°F (85°C)
195°F (91°C)	206°F (97°C)	T4	275°F (135°C)
250°F (121°C)	272°F (133°C)	T3	392°F (200°C)

## Maximum Allowable Horsepower

Do not exceed the maximum horsepower rating for the pump coupling. Refer to the chart below. Use the first six or seven characters from the model number listed on the label found on the motor adapter.

Magnet Set	60 Hz (3500 RPM)		50 Hz (2900 RPM)		30 Hz (1750 RPM)		25Hz (1450 RPM)	
	HP	kW	HP	kW	HP	kW	HP	kW
B	20	15	15	11	10	7.5	7.5	5.5
C	40	30	30	22	20	15	15	11
D	60	45	50	37	30	22	25	18.5
E	75	55	60	45	-	-	30	22

# Minimum Allowable Flow Rate

Do not allow the flow rate to drop below the minimum flow rate listed in the chart below. Use the first five or six characters from the model number listed on label found on the motor adapter.

Model	Minimum GPM @ 3500 RPM	Minimum M3/Hr @ 2900 RPM	Minimum GPM @ 1750 RPM	Minimum M3/Hr @ 1450 RPM
UC3158	20	3.8	10	1.9
UC3158	20	3.8	10	1.9
UC438	20	3.8	10	1.9
UC438	20	3.8	10	1.9

## UC3158, UC328, UC436, & UC438

Model Codes and Abbreviations

Base	Magnet Set	Casing/Flange	Coupling	Bushing	Shaft	O-ring	Thrust Ring	Impeller	Motor Adapter	Motor	
<b>UC3158</b>	<b>B</b> (up to 20 hp)	ETFE lined ductile iron	<b>C</b> (Close coupled)	<b>S</b> (SiC)	<b>S</b> (SiC)	<b>V</b> (FKM)	<b>S</b> (SiC)	<b>600</b> -6" to <b>825</b> -8-1/4"	<b>NEMA 14</b> (143/145TC)	<b>IEC 90</b> (90/B5)	2 Digit Ref. No.
<b>UC438</b>	<b>C</b> (up to 40 hp)	<b>O</b> (ANSI 150#)	<b>F</b> (Frame mounted)	<b>C</b> (Carbon)	<b>D</b> (Dri-Coat SiC+)	<b>E</b> (EPDM)			<b>10</b> (100/112 B5)	See Motors Section	
<b>UC436</b>	<b>D</b> (up to 60 hp)	<b>T</b> (ANSI 300#)		<b>D</b> (Dri-Coat SiC+)		<b>K</b> (Kalrez)			<b>18</b> (182/184TC)		
<b>UC328</b>	<b>E</b> (up to 75 hp)	<b>I</b> (ISO PN40)				<b>S</b> (Simrez)			<b>21</b> (213/215TC)		
						<b>A</b> (Aflas)			<b>19</b> (180 B5)		
									<b>25</b> (254/256TC)		
									<b>22</b> (225 B5)		
									<b>28</b> (282/284 TC)	<b>Frame Mounted</b>	
									<b>29</b> (282/284 TSC)	<b>FO</b> (Frame Mount)	
									<b>32</b> (324/326 TC)	<b>FB</b> (Frame Mount)	
									<b>33</b> (324/326 TSC)		
									<b>36</b> (364/365 TC)		
									<b>37</b> (364/365 TSC)		

# Unpacking and Inspection

Unpack the pump and examine for any signs of shipping damage. If damage is detected, save the packaging and notify the carrier immediately.

To install the pump, follow the installation instructions provided.

**⚠ WARNING:** The pump and associated components are heavy. Failure to properly support the pump during lifting and movement could result in serious injury or damage to the pump and components.

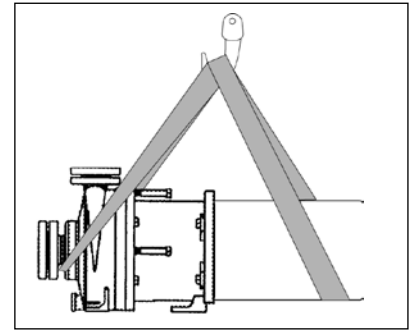

# Model Number and Serial Number

Record the model number and serial number for future reference. Use the location provided on the front cover of this manual. This is important information when ordering replacement parts or when technical assistance is required. The model and serial number are found on a label located on the motor adapter.

# Installation

To install a motor to a pump end, see section Assembly of Pumps without Motors, and then proceed to section Foundation.

**Note:** A hydrostatic test was performed prior to shipment. It is normal for a small amount of water to be retained inside the pump.

## Pumps with Motors: Proceed to Foundation Section.

## Pumps without Motors:

1. Prepare to install the motor on the pump. Carefully place the motor and pump end on a suitable, level work surface (a nonmagnetic surface is preferred). Make sure the work surface is free of metal chips or particles.

**⚠ Magnetic Force Hazard.** This pump should only be disassembled and assembled using the recommended procedures. The magnetic attraction is powerful enough to rapidly pull the motor end and the wet end together. ALWAYS use the jackscrews (item 14) to assemble/disassemble the pump. Do not place fingers between the mating surfaces of the motor and wet ends to avoid injuries. Keep the drive magnet and impeller assembly away from metal chips or particles.

**⚠ CAUTION:** Keep the drive hub away from the open end of the motor adapter and barrier. Strong magnetic attraction could allow the drive hub to enter the motor adapter resulting in injury or damage.

2. Using a 24 mm socket, unbolt the wet end (items 1-7) from the motor adapter by removing the (4) M16 hex head cap screws (item 15). Make sure the (2) jackscrews (item 14) are fully extended. Using a 24 mm socket turn the jackscrews clockwise until they are fully extended. See figure 1.
3. Coat the motor shaft with anti-seize paste. Slide the drive shaft adapter (item 8B) onto the motor shaft with the key in the keyway. Slide the adapter until the retaining ring touches the end of the motor shaft. See figure 2.

A. For installation onto NEMA motor frames:

- i. Using a 3/16" - "T" handled Allen wrench, tighten both setscrews to 228 in-lbs. (25.8N-m)

B. For installation onto IEC motor frames:

- i. Install flat washer, lock washer, and bolt (items 18, 19 & 20) into the end of the motor shaft and then tighten to the following torque settings:

- IEC 90 B5- M8-1.25: 120 in-lbs (13.7 N-m)
- IEC 100/112 B5- M10-1.5: 250 in-lbs (28.2 N-m)
- IEC 132 B5- M12-1.75: 35 ft-lbs (47.5 N-m)
- IEC 160/180 B5- M16-2.0: 90 ft-lbs (122 N-m)
- IEC 200/225 B5- M20-2.5: 90 ft-lbs (122 N-m)

**Note:** The shaft adapter is held to a tight tolerance (+0.0005"/-0.0000) to the motor shaft, so it may be necessary to tap the shaft adapter with a soft faced mallet to fully seat it. Be careful to not damage the shaft adapter during this process.

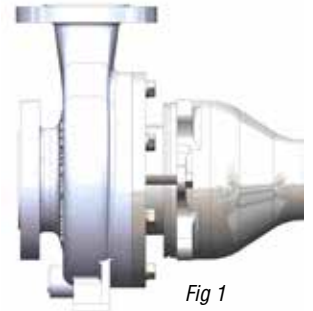

Fig 1

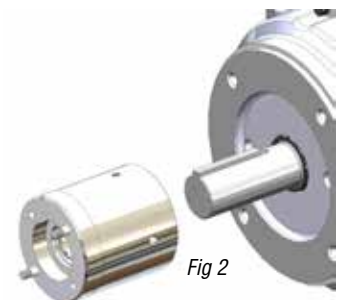

Fig 2

- Install vapor protection o-ring (item 25) in the groove on the back of the motor adapter (item 9) use petroleum jelly or similar substance to help hold the o-ring in place. Slide the motor adapter over the shaft adapter and attach it to the motor face. Use the (4) supplied hex head cap screws & lock washers (items 16 & 16A) and torque evenly to the following values. See figure 3.

NEMA 145TC- 3/8-16—15 ft-lbs

NEMA 184/215/254/284/286- 1/2-13—75 ft-lbs

NEMA 324/364—5/8-11-- 90 ft-lbs

**Note:** FTI does not supply these bolts for IEC B5 motors due to variations in B5 flanges

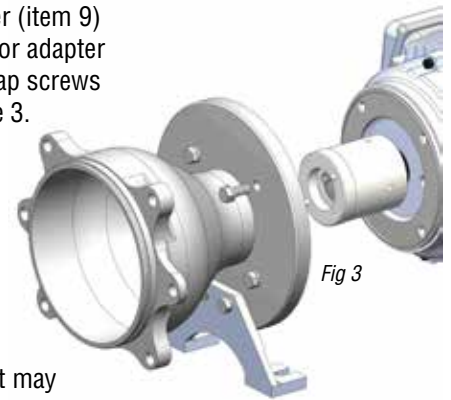

Fig 3

- Lightly coat the bore of the magnet hub (item 8A) with anti-seize paste. See figure 4. Using the two threaded studs, carefully slide the magnet hub onto the shaft adapter. It may be necessary to lightly tap, or use the supplied hex head bolts to pull the hub into position. Use the supplied (2) hex head bolts, (4) lock washers and (2) hex nuts (items 21, 22 & 23) to secure the magnets into position. Torque the bolts and nuts (M8) to 120 in-lbs (13.7 N-m).

**Note:** Use supplied cardboard to help protect the outer drive magnets from damage from tools. Be sure to remove the tube after drive is securely attached. Save tube should any future repairs be necessary. If your pump did not ship with one of these tubes, please consult the spare parts list for ordering information.

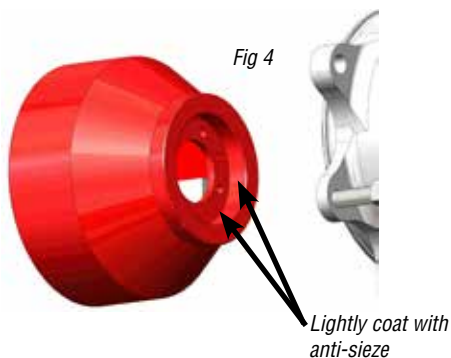

Fig 4

Lightly coat with anti-seize

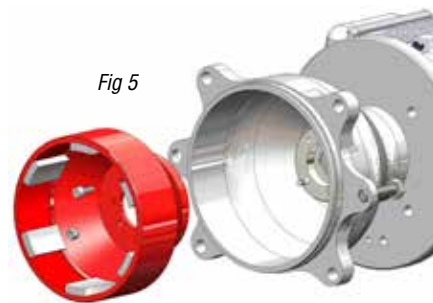

Fig 5

- Lubricate the vapor protection o-ring (item 24) on the front of the motor adapter with petroleum jelly. See figure 6.
- Carefully slide the wet end towards the motor adapter until it touches the jackscrews (item 14) there will be some magnetic attraction. Make sure the (2) jackscrews are fully extended. See figure 7.
- Slowly and evenly turn the jackscrews counterclockwise to allow the wet end to slowly slide into the motor adapter. When the jackscrews are fully retracted, lift the wet end slightly and slide it onto the motor adapter's locating flange. If necessary the M16 motor adapter bolts may be used to draw the pump end onto the motor adapter. Be careful not to cut or damage the vapor protection o-ring (item 24).
- Bolt the wet end to the motor adapter by reinstalling the (4) M16 hex head cap screws & lock washers (items 15 & 15A) and torque evenly to 90 ft-lbs (122 N-m). See figure 8.

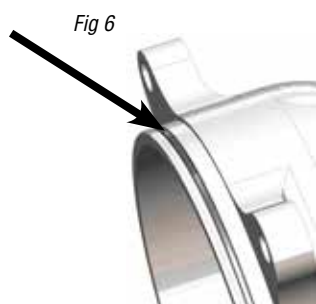

Fig 6

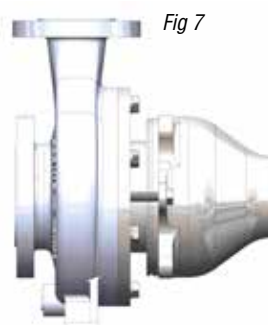

Fig 7

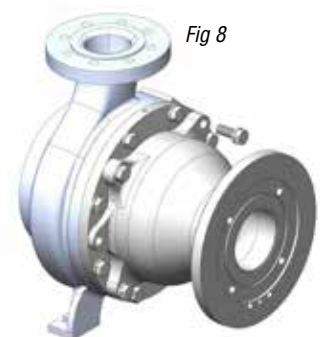

Fig 8

## Foundation

1. The foundation that the pump will be sitting on should be strong enough to support the pump as well as absorb any vibration that the pump will produce. A concrete platform should be acceptable. Bolts embedded in the concrete can be placed by using a template or drawing. The use of a pipe sleeve larger than the bolt will compensate for base movement for final bolt location.
2. You must allow a gap no greater than 1-1/2" between base and foundation for grouting

## Base plate

1. The base plate of the ULTRAChem must be placed on the foundation using two sets of wedges or shims. These shims should be placed on each side of the foundation bolts. Provide enough clearance for proper grouting.
2. Remove any water or other debris from the anchor bolt holes prior to grouting.
3. Carefully lower the base plate onto the foundation bolts.
4. Level the base plate to within 1/8-inch over the length and 1/16-inch over the width. This can be done by adjusting the wedges.
5. Hand tighten the bolts.

## Grout the base plate

1. Ensure that the area that is to be grouted is clean. Follow instructions from the grout manufacturer.
2. Erect a dam around the foundation. Insure that the foundation is thoroughly wetted.
3. Pour grout in the dam and completely fill under and around the base plate to the level of the dam. Make sure that any air bubbles are removed as it is poured. It is recommended that non-shrinking grout be used.
4. Permit the grout to set at least 48 hours.
5. Tighten the foundation bolts.

**⚠ CAUTION:** Do not operate the pump until it is securely fastened!

## Piping

1. The pump should be installed as near to the suction source as possible.
2. It is recommended that pipes are supported as close as possible to the pump and all flanges line up. This will minimize any pipe strain.
3. The suction side of the pump should be as straight and short as possible to minimize pipe friction or a length at least ten times the inlet diameter should follow any elbows.
4. The suction or inlet line should be at least as large as the suction inlet port or one pipe size larger so that it does not affect the NPSHa. Do not reduce the suction line size.
5. The suction line should not have any high spots. This can create air pockets. The suction piping should be level or slope slightly upward to the pump. See figure 9.
6. The NPSH available to the pump must be greater than the NPSH required. Filters, strainers, and any other fittings in the suction line will lower the NPSH available and should be calculated into the application.

Fig 9

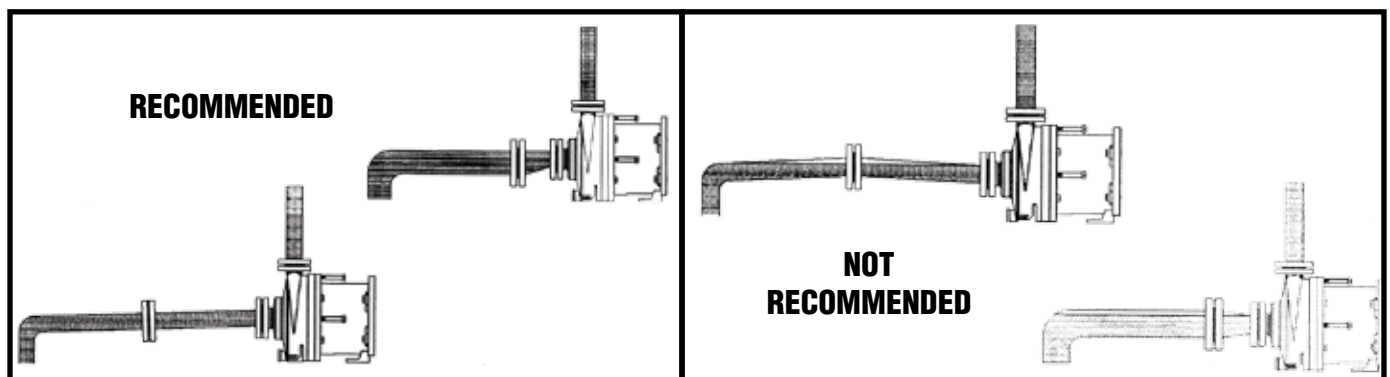



- A check valve and a control valve (if used) or isolation valve should be installed on the discharge line. The control valve is used for regulating system flow. An isolation valve is used to make the pump accessible for maintenance. It is recommended that the control or isolation valve be closed prior to stopping or starting the pump. The check valve is installed to protect the pump against water hammer damage. These recommendations are particularly important when the static discharge head is high.
- It is advisable to install a flush system in the piping to allow the pump to be flushed before the pump is removed from service.
- When connecting piping to the pump suction and discharge flanges, if lock washers are used, install under the head of the bolt. See figure 10.

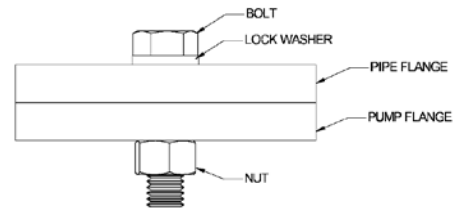

Fig 10

## Motor/Electrical

Install the motor according to NEC requirements and local electrical codes. The motor should have overload protection. The use of a power monitor is highly recommended.

**Note:** All ATEX certified pumps must use a power monitor.

- The motor must be installed with flexible conduit in order to allow a minimum of 6" of motor movement so that the pump can be disassembled.
- Check all electrical connections with the wiring diagram on the motor. Insure that the voltage, frequency, and horsepower on the motor comply with the line circuitry.
- If utilized, check that the power monitor has been properly installed in accordance with the manufacturer's directions.

**CAUTION:** Do not operate the pump to check rotation until the pump is full of liquid.

## Operation

### Pre-Operation Inspection

Prior to the first operation of the pump, perform the following inspections:

**WARNING:** Lock out power to the driver to prevent accidental motor start-up and physical injury.

- Insert a screwdriver through the fan cover and rotate the fan. It should move without restrictions.
- Verify that all flange and hold down bolts are tightened.

### Start-up and Operation

- This pump must be filled from a flooded suction tank (gravity) or primed with liquid from an outside source.
- The ULTRACHEM is not self-priming.
- Ensure that the pump is full of liquid and the inlet (suction) valve is open.
- Open the outlet (discharge) valve completely and then close it so that there is no trapped air in the suction and discharge line.
- After the pump is full of liquid, check that the rotation of the motor/ pump is in the correct direction. This can be achieved by jogging the motor for approximately ½ second. The motor rotation can be observed from the fan end. Correct rotation when viewed from the fan end is clockwise.
- Note:** A pump running backwards will pump but at a greatly reduced flow and pressure.
- Turn the pump on. Slowly open the discharge valve. Check pump for proper flow and pressure, and that pump runs without excessive noise or vibration.
- Keep the suction valve in the fully open position. Never use the suction valve to regulate the flow rate. Use the discharge valve only.

**Note:** It is not necessary to jog the motor or adjust the valves on subsequent pump starts provided that the pump and piping remain full of liquid.

- ⚠ CAUTION:** Do not run the pump dry. This could damage the pump. The fluid being transferred by the pump lubricates the pump. Even short periods of running the pump dry could damage the pump. It is recommended that a run dry protection device be used.
- ⚠ CAUTION:** Do not dead head the pump. Running the pump at zero flow will cause any liquid inside the pump to elevate rapidly in temperature. This will continue until the boiling point of the liquid is reached. The liquids will flash to vapor, causing the pump to run dry, and destroy the pump. Run dry protection in the form of a power monitor is recommended.
- ⚠ WARNING:** All ATEX compliant pumps must use a power monitor to protect against running dry, closed discharge valve, and pump decoupling. Any of these conditions could lead to elevated surface temperatures.
- ⚠ CAUTION:** Cavitation for an extended period of time can cause pitting and damage on the pump components. Make certain NPSHa is greater than pump NPSHr.
- ⚠ CAUTION:** Water hammer. Rapid changes in the fluid's velocity can cause large, sudden pressure surges. These pressure surges can damage the pump, plumbing and instrumentation. Common causes are rapidly closing valves. Check valves on the suction can also cause water hammer if the liquid has time to reverse direction before the valve closes.

## Shutdown

Use the following procedures to shut the pump down.

1. Slowly close the discharge valve .
2. Shut off the motor.
3. Close the suction valve.

## Disassembly/Reassembly

### Disassembly

#### Pump End

- ⚠ WARNING:** Rotating Parts. This pump has components that rotate while in operation. Follow local safety standards for locking out the motor from the power supply during maintenance or service.
  - ⚠ WARNING:** Chemical Hazard. This pump is used for transferring many types of potentially dangerous chemicals. Always wear protective clothing, eye protection and follow standard safety procedures when handling corrosive or personally harmful materials. Proper procedures should be followed for draining and decontaminating the pump before disassembly and inspection of the pump. There may be small quantities of chemicals present during inspection.
  - ⚠ WARNING:** The pump must be thoroughly flushed of any hazardous materials and all internal pressure relieved prior to opening the pump. Shut all valves controlling flow to and from pump. Isolate pump from system and relieve any remaining system pressure before any plugs are removed or piping is disconnected.
  - ⚠ WARNING:** Magnetic force hazard. This pump should only be disassembled and assembled using the recommended procedures. The magnetic attraction is powerful enough to rapidly pull the motor end and the wet end together. ALWAYS use the jackscrews (item 14) to assemble/disassemble the pump. Do not place fingers between the mating surfaces of the motor and wet ends to avoid injuries. Keep the drive magnet and impeller assembly away from metal chips or particles.
1. Stop the pump, lock out the motor starter, close all the valves that are connected to the pump, and drain/decontaminate the pump. The ULTRACHEM is supplied with a casing drain to help drain and decontaminate the pump. If the drain flange has been removed to drain/decontaminate the pump, reinstall the flange (item 11) and use a new gasket (item 11A). Torque the two flange bolts (M12) (item 11B) to 35 ft-lbs (47.5 N-m).
  2. Allow the pump to reach ambient temperatures prior to performing maintenance.
  3. Remove the mounting bolts that attach the motor to the base, if any.
  4. Using a 24 mm socket, remove the (4) M16 bolts that secure the motoradapter to the clamp ring. See figure 10.

Fig 10



- Separate the magnetic coupling between the drive end and the pump end by using the two jackscrews (item 14). Using a 24 mm socket turn the jackscrews clockwise. Be sure to turn the jackscrews evenly. Turn the jackscrews until they are fully extended. See figure 11.

**⚠ CAUTION:** After removal of the drive end, the jackscrews should be left fully engaged in the adapter to prevent accidental attraction of the magnetic coupling.

- Using a 24 mm socket, remove the (8) M16 hex head bolts that connect the clamp ring (item 7) to the casing. See figure 12.
- Remove the clamp ring from the back of the barrier assembly.
- Place the casing/barrier assembly on a table with the suction flange of the casing facing down. Carefully remove the barrier assembly from the casing. When pulling the barrier assembly out of the casing, the shaft may stick in the barrier. If this happens, make sure that the shaft does not drop out when the barrier assembly is removed or damage may result. See figure 13.
- Remove the impeller assembly and the shaft from the casing.

**⚠ CAUTION:** The shaft and impeller can be damaged if dropped.

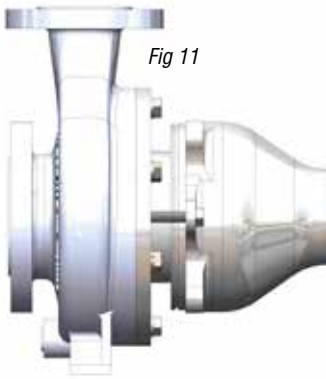

Fig 11

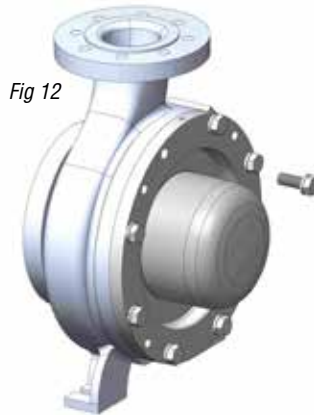

Fig 12

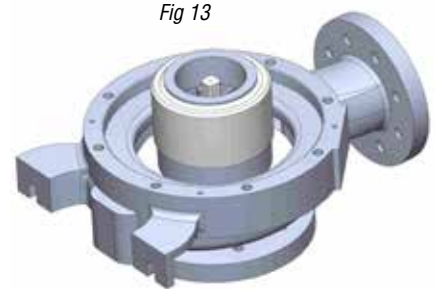

Fig 13

## Power End (motor side)

**⚠ WARNING:** This pump should only be disassembled and assembled using the recommended procedures. The magnetic attraction is powerful enough to rapidly pull the motor end and the wet end together. ALWAYS use the jack-screws (item 14) to assemble/disassemble the pump. Do not place fingers between the mating surfaces of the motor and wet ends to avoid injuries. Keep the drive magnet and impeller assembly away from metal chips or particles.

- Using a 13 mm socket, remove the (2) M8 hex head cap screws (item 23) and two M8 hex nuts (item 21) that hold the outer magnet ring to the shaft adapter. If necessary, use the two M8 hex bolts as jack screws in the tapped holes of the magnet ring. See figure 14.

**Note:** A cardboard tube is available that helps protect the outer drive magnets from damage. If you do not have one of these tubes, please consult the spare parts list for ordering information.

- Using the appropriate socket, remove the four hex bolts (item 16) that attach the motor adapter to the motor. Carefully slide the motor adapter off the motor face and over top of the shaft adapter. See figure 15.
- Inspect the shaft adapter for damage. To remove it from the motor shaft:
  - For pumps with a NEMA motor: Loosen the setscrews (item 27) on the shaft adapter and remove it from the motor shaft.
  - For pumps with an IEC frame motor - loosen and remove the bolt and washers (items 18, 19 & 20) in the center of the shaft adapter and pull it off the end of the motor shaft.

**Note:** The shaft adapter is held to a tight tolerance (+0.0005"/-0.0000) to the motor shaft, so it may be necessary to use pry bars to help remove it. Be careful to not damage the motor face or motor shaft during this process.

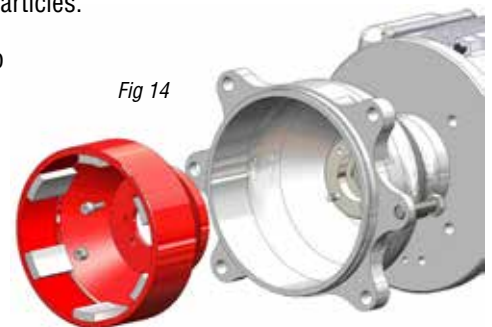

Fig 14

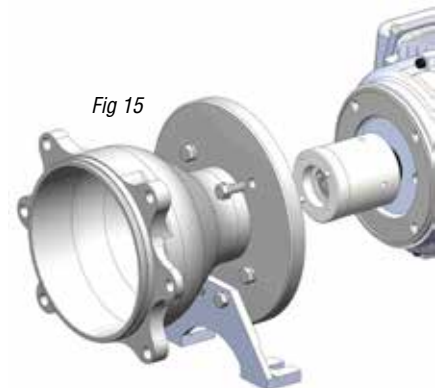

Fig 15

## Examination

The first scheduled inspection should take place after the first three months or approximately after 2000 hours of run time. This is to insure that there is no damage from any solids or particulate, cavitation or run dry. Re-inspect after six to twelve months depending on the results of the initial inspection.

**Note:** All pumps should be checked for leaks on a regular basis. If any leaks are detected, the pump should be repaired immediately.

**Note:** A new o-ring will be required after pump inspection. If the drain flange is removed, replace the gasket

1. Inspect the bushings (item 4A). The silicon carbide parts will not wear under normal operation. Polishing on a silicon carbide surface is a normal occurrence and usually does not require replacement. Check for signs of melting around the perimeter of the bushings. Make sure that the groove on the bushing ID is not plugged. Check for chips or cracks. Check bushings for wear. If the bushings appear worn, follow the steps listed in the section "Replacing Wear Components, Impeller Bushings". See figure 16.

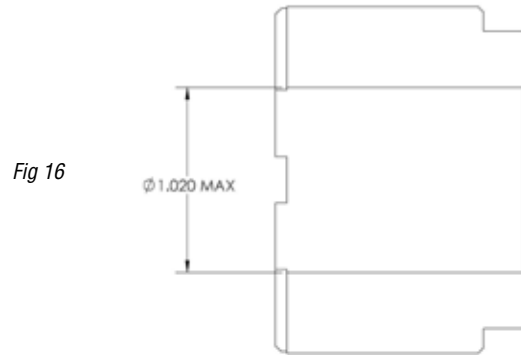

2. Check for cracks or excessive wear on the shaft (item 5), impeller thrust ring (item 3A) and rear sealing ring (item 4C). Replace if cracked or excessively worn.
3. Check for signs of deformation or melting in the shaft support (item 2) and the barrier assembly (item 6) where the pump shaft is positioned. Dry running of the pump during initial start-up or operation will cause heat-related damage to these components.
4. Inspect the casing liner (item 1). It is important that there are no abrasions or cuts deeper than .04 inch in the lining. These cracks may occur if the lining is corroded or abraded. Liner damage can usually be detected visually. Some hairline cracks require an electrostatic discharge tester to detect.
5. Locate the impeller assembly (item 3). Make certain that there are no obstructions. If there is an obstruction or product build up in any of the flow paths, an imbalance will cause excessive vibration and wear on the pump shaft and impeller bushings.
6. Check the impeller drive assembly (item 4) for cracks or grooves larger than .02 inch. If a fluid comes in direct contact with the magnets, the magnets may swell, cause rubbing, and damage the barrier assembly (item 6).
7. Inspect the barrier assembly (item 6) for signs of abrasion. Replace the barrier assembly if there are grooves or scratches that are deeper than .04 inch.

## Replacing Wear Components

Use the following procedures to replace any wear components that are excessively worn, cracked or broken.

### Shaft Support/Front Thrust Washer Removal

1. Remove the casing (item 1) from the base plate and piping.
2. Place the casing in an arbor press with ETFE lining side down. Note: care should be taken to not damage the lining.
3. Place arbor on the nose of the front shaft support (item 2) and carefully press the front shaft support out of casing. See figure 17. Note: Care should be taken to not damage the silicon carbide thrust ring (item 2A). Use something soft to catch the shaft support as it drops from the casing.



Fig 17

### Installation of Replacement Support/Front Thrust Washer

1. Place the casing in an arbor press with the suction flange down.
2. If the silicon carbide thrust ring (item 2A) is damaged and needs to be replaced the PTFE o-ring (item 2B) should also be replaced. Remove the thrust ring by hand. Install the new o-ring in the groove and press the new thrust ring into the shaft support being sure to line up the 4 slots in the ring with the four tabs on the shaft support.
3. Position the front shaft support in the bore of the casing suction and align the anti-rotation pins on the front shaft support with the blind slots in the casing.
4. Press evenly on the face of the plastic shaft support with a soft-faced arbor until the front shaft support is fully seated in the bore.

### Impeller Thrust Ring

The impeller thrust ring is located in the front of the impeller shroud.

#### Removal

1. The silicon carbide impeller thrust ring (item 3A) must be broken to remove it from the impeller. Be careful not to damage the bore or face of the front impeller shroud. Silicon carbide is brittle and can be broken easily by hitting it with a hammer. Care should be taken during this process to prevent personal injury from flying debris or sharp edges. Wear proper safety clothing.

Note: A new impeller thrust ring with PTFE encapsulated o-ring will be required after removal.

#### Replacement

1. Place the impeller and impeller drive assembly (items 2B, 3, 3A, 4, 4A & 4C) on a table with the eye of the impeller facing up.
2. Using petroleum jelly or similar substance, place the o-ring (item 2B) into the groove on the rear of the impeller thrust ring (item 3A). See figure 18.
3. Position the replacement impeller thrust ring in the bore of the front shroud with the snap fit ridge towards the bottom of the bore. See figure 19. Align the two anti-rotation slots on the impeller thrust ring with the two raised bosses of the impeller shroud.
4. Place the impeller and impeller drive assembly in an arbor press. Using a soft faced arbor, gently press the impeller thrust ring into place. Make sure thrust ring is completely seated. See figure 20.



Fig 18

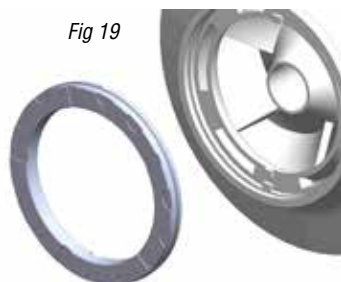

Fig 19



Fig 20

## Rear Sealing Ring

The rear sealing ring (item 4C) is located in the rear bore of the barrier assembly (item 6).

### Removal

1. The rear sealing ring fits into the barrier assembly with a snap fit. To remove the existing sealing ring, cut a notch in the ring using a standard razor knife and remove.

### Replacement

1. Place the barrier in an arbor press.
2. Place rear sealing ring on the rear bore of the barrier and align anti-rotation tabs on the rear sealing ring with the pockets in the barrier. See figure 21.
3. Using a soft faced arbor, press in the ring. The sealing ring is fully seated when the bottom face of the ring is in contact with the bottom of the barrier. You can hear and feel the ring snap into place. See figures 22 & 23.

*figure 21*



*figure 22*

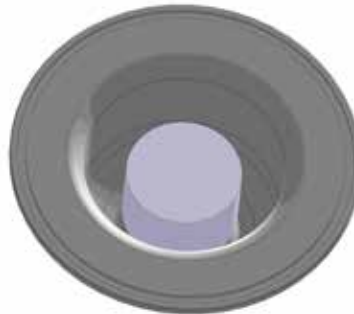

*figure 23*



## Impeller Assembly Removal and Replacement

The impeller assembly can be replaced as required to change the impeller diameter or replace damaged or worn vanes.

### Removal

1. Holding the impeller (item 3) and impeller drive assembly (item 4) by hand, place a 3/8-inch diameter rod (or a 3/8" ratchet extension) through the perforations in the bore of the impeller drive assembly. See figure 24.
2. While holding the impeller drive assembly tap on the rod with a hammer in several locations until the impeller assembly separates from the impeller drive assembly.

*figure 24*

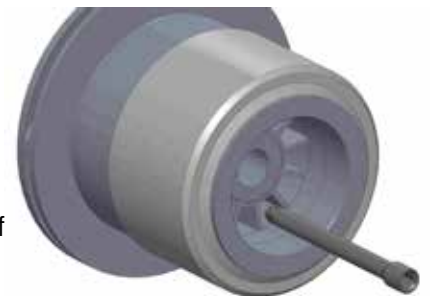

### Replacement

1. Place the impeller drive assembly (item 4) in an arbor press with the kidney shaped slots facing up.
2. Align the kidney-shaped drive pins on the impeller assembly (item 3) with the kidney-shaped slots in the impeller drive assembly and press partially in by hand.
3. Complete installation by pressing the impeller assembly into the impeller drive assembly with an appropriate size arbor (be sure the arbor does not touch the impeller thrust ring (item 3A) use an arbor with a larger diameter than the eye of the impeller) until the back side of impeller rear shroud is flush with front face of impeller drive assembly. See figure 25.

*figure 25*



## Impeller Bushings

### Removal

1. Remove the impeller according to the steps listed in the section Impeller Assembly, Removal.
2. The front bushing (closest to the impeller) should be floating and be able to be removed by hand. For the rear bushing, place the impeller drive assembly on an arbor press with the of the impeller drive facing up
3. Insert a 1-1/4" diameter arbor into the bore of the impeller drive assembly.
4. Press on face of rear impeller bushing until the bushing has been removed. Check both bushings for excessive wear.
5. Check the impeller bore for signs of plastic melting or fretting wear.

### Replacement

1. Place the impeller drive assembly in an arbor press with the impeller side facing down.
2. Start the rear bushing into bore of impeller while lining up the four flats on the bushing with the flats in the impeller drive. The interrupted face end of the bushing should be facing up. Press the bushing into the impeller bore with a 1-3/4" diameter soft-faced arbor. See figure 26.
3. To install the front bushing, turn the impeller drive over. The interrupted face of the bushing should be facing up. Align the four flats on the bushing with the four flats in the impeller drive. The front bushing will slide easily into place. The face of the bushing should be approximately flush with the top of the impeller drive. Note: Make sure bushing does not fall out & get damaged during reassembly.
4. Reinstall the impeller according to the steps listed in the section Impeller Assembly, Replacement.

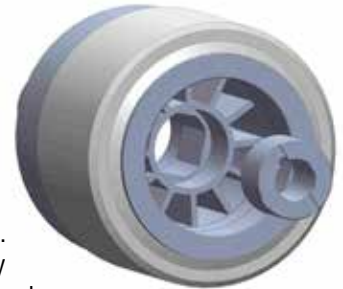

figure 26

## Power End Reassembly

See section Assembly of Pumps without Motors, steps 1-9 on pages 6-8.

### Pump End Reassembly

1. Take the pump casing (item 1) and lay it suction side down on a clean flat surface. See figure 27. Note: Care should be taken to not damage the lining.
2. Carefully place the impeller (item 3) and impeller drive assembly (item 4) into the housing onto the thrust ring. See figure 28.  
**CAUTION:** Do not use steel/iron tools near the magnets. These tools are attracted to the strong magnetic force and could damage them upon impact.
3. If removed, reinstall the shaft (item 5) align the four flats on the one end with the flats on the barrier assembly and push in by hand. Install a new o-ring (item 12) in the barrier assembly's (item 6) o-ring groove. Use petroleum jelly or similar chemically compatible substance to help hold the o-ring in position. See figure 29.
4. Slide the barrier and shaft assembly over the impeller assembly and through the bushings. Align the shaft with the front shaft support. Press down on the barrier assembly until it is fully seated. See figure 30.

figure 27

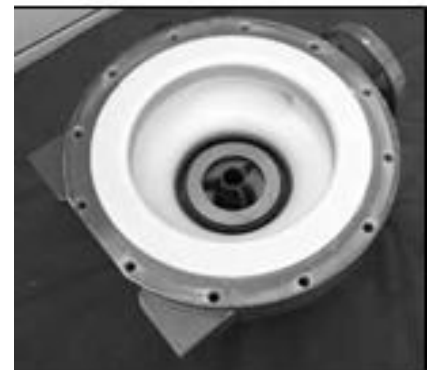

figure 28



figure 29



figure 30



5. Make sure the vapor protection o-ring (item 24) is in the clamp ring groove (item 7). Place the rounded edge of the clamp ring over the barrier assembly and position on the rear face of the casing. **Note:** It is important to properly line up the 8-through holes in the clamp ring to the 8 threaded holes in the casing. See figure 31. The 4 threaded holes in the clamp ring should align per figure 31a.
6. Attach the clamp ring with (8) M16 hex head cap screws and lock washers (items 13 & 13A). Tighten evenly around circumference. Torque the screws to 90 ft-lbs (122 N-m) unlubricated.
7. Lubricate the vapor protection o-ring on the front side of the motor adapter using a compatible lubricant. See figure 32.
8. Make sure the (2) jackscrews (item 14) are fully extended. If not turn the (2) jackscrews clockwise until the heads touch the motor adapter.
9. Carefully slide the wet end towards (items 1-7) the motor adapter (item 9) until it touches the jackscrews (there will be some magnetic attraction). See figure 33.
10. Slowly and evenly turn the jackscrews counterclockwise to allow the wet end to slowly slide into the motor adapter. Be careful not to cut the o-ring as the assembly is put together. When the jackscrews are fully retracted, if necessary use the (4) M16 hex head bolts (item 15) to draw the pump end onto the motor adapter.
11. Bolt the wet end to the motor adapter by installing the (4) M16 hex head cap screws & lock washers (items 15 & 15A) and torque evenly to 90 ft-lbs (122 N-m). See figure 34.



figure 31

figure 31a

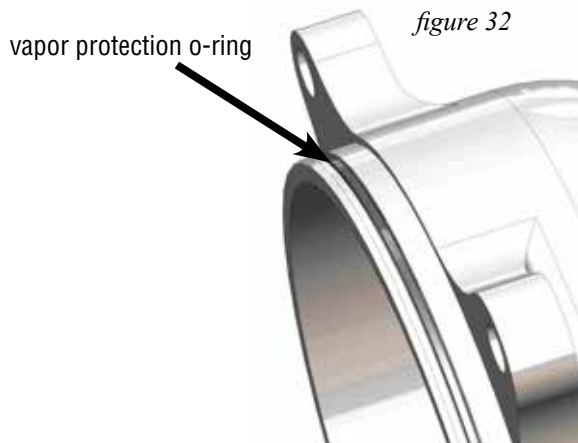
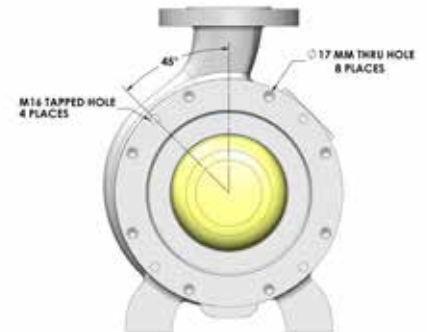

figure 32

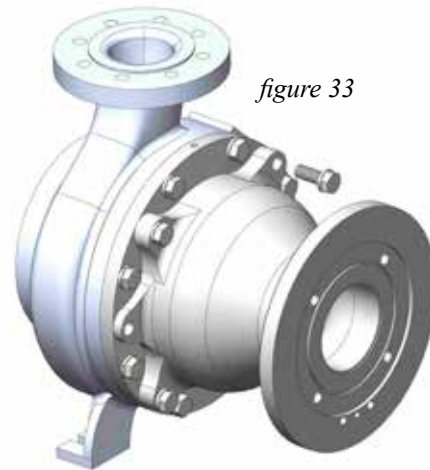
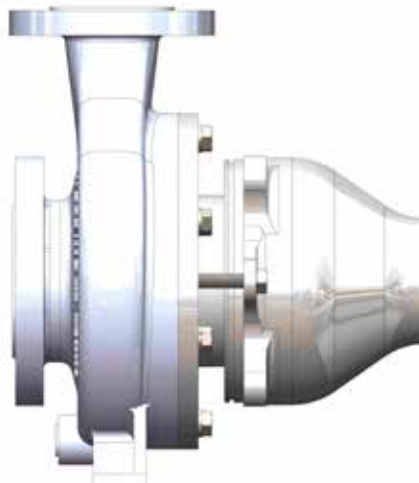

figure 33

figure 34





## TROUBLESHOOTING

### NO OR INSUFFICIENT DISCHARGE

- Air leaks in suction piping.
- Pump not primed.
- Discharge head higher than anticipated.
- Closed valve.
- Viscosity or specific gravity too high (magnets uncoupled).
- Suction lift too high or insufficient NPSH.
- Clogged suction line or impeller vanes.
- Motor rotation incorrect (correct rotation when viewed from the fan end is clockwise).

### INSUFFICIENT PRESSURE

- Air or gas in liquid.
- Impeller diameter too small.
- System head lower than anticipated.
- Motors speed insufficient (too low) or motor rotation incorrect (correct rotation when viewed from the fan end is clockwise).

### LOSS OF PRIME

- Leaking suction line.
- Foot valve or suction opening not submerged enough.
- Foot valve too small or leaking.
- Air or gas in liquid.
- Foreign matter in impeller.
- Leaking valve. Suction lift too high or insufficient NPSH.

### EXCESSIVE POWER CONSUMPTION

- Head lower than rating.
- Excessive flow.
- Specific gravity or viscosity too high.

### VIBRATION/NOISE

- Loose magnet.
- Drive magnet rubbing.
- Pump cavitation from improper suction or feed.
- Motor or piping not properly secured.
- Foreign object in impeller.

### IMPORTANT NOTICE

**U.S. Export Administration Regulations, pursuant to ECCN 2B350, prohibit the export or reexport to certain enumerated countries of sealless centrifugal pumps in which all wetted materials are constructed from fluoropolymers without first applying for and obtaining a license from the U.S. Bureau of Industry and Security (BIS). This affects all Finish Thompson magnetic-drive pumps constructed from PVDF or lined with ETFE. Please contact the BIS ([www.bis.doc.gov](http://www.bis.doc.gov)) or Finish Thompson with questions regarding the Regulations or a list of the countries to which they apply.**

### CHEMICAL REACTION DISCLAIMER

The user must exercise primary responsibility in selecting the product's materials of construction, which are compatible with the fluid(s) that come(s) in contact with the product. The user may consult Finish Thompson, Inc. (manufacturer) and a manufacturer's representative/distributor agent to seek a recommendation of the product's material of construction that offers the optimum available chemical compatibility.

However neither manufacturer nor agent shall be liable for product damage or failure, injuries, or any other damage or loss arising out of a reaction, interaction or any chemical effect that occurs between the materials of the product's construction and fluids that come into contact with the product's internals.

### HELPFUL HINTS

Do not pump liquids containing ferrous metal fines.

If magnets de-couple, stop the pump immediately. The rare earth magnets used in this pump are more resistant to demagnetization, but operating the pump with the magnets de-coupled will eventually weaken the magnets.

A power monitor is strongly recommended. This device will help protect the pump against abnormal operating conditions such as dry running, magnet de-coupling, cavitation, etc.

Power monitors are required and must be used with all ATEX certified pumps.

The setting of the drive magnet dimension is critical. Failure to properly set the dimension may result in de-coupling or damage to pump components.

Do not use mismatched drive magnet assemblies (impeller drive magnet and the outer drive magnet assembly). The drives are marked with either an "A" or "B". Use only components with the same drive letter designation. A serial number plate is attached to the motor adapter section.

Call our toll free Technical Service Hot Line, 1-800-888-3743, if you have any questions regarding product operation or repair.

### ORDERING SPARE PARTS

Spare parts can be ordered from your local distributor. Always refer to the pump model number to avoid error.

### OTHER FINISH THOMPSON PUMP PRODUCTS

Drum Transfer Pumps are available in sanitary construction, Stainless steel, polypropylene and CPVC. Flows to 40 gpm, Discharge heads to 300 feet and viscosities to 100,000 cps.

Portable Mixers for turbine mixing and blending handle viscosities to 1,000 cP with gentle, non-vortexing circulation. Available in 316 stainless steel construction.

Centrifugal Pumps in polypropylene, PVDF, stainless steel, or Hastelloy C come with a wide variety of sealing materials. Flows to 330 gpm, discharge heads to 275 feet, and temperatures to 220°F (104°C)

For more information contact Finish Thompson Inc. Call our toll free Technical Service Hot Line, 1-800-888-3743, if you have any questions regarding product operation or repair.

# UC436, UC438, UC328, & UC3158 EXPLODED VIEW PARTS DIAGRAM

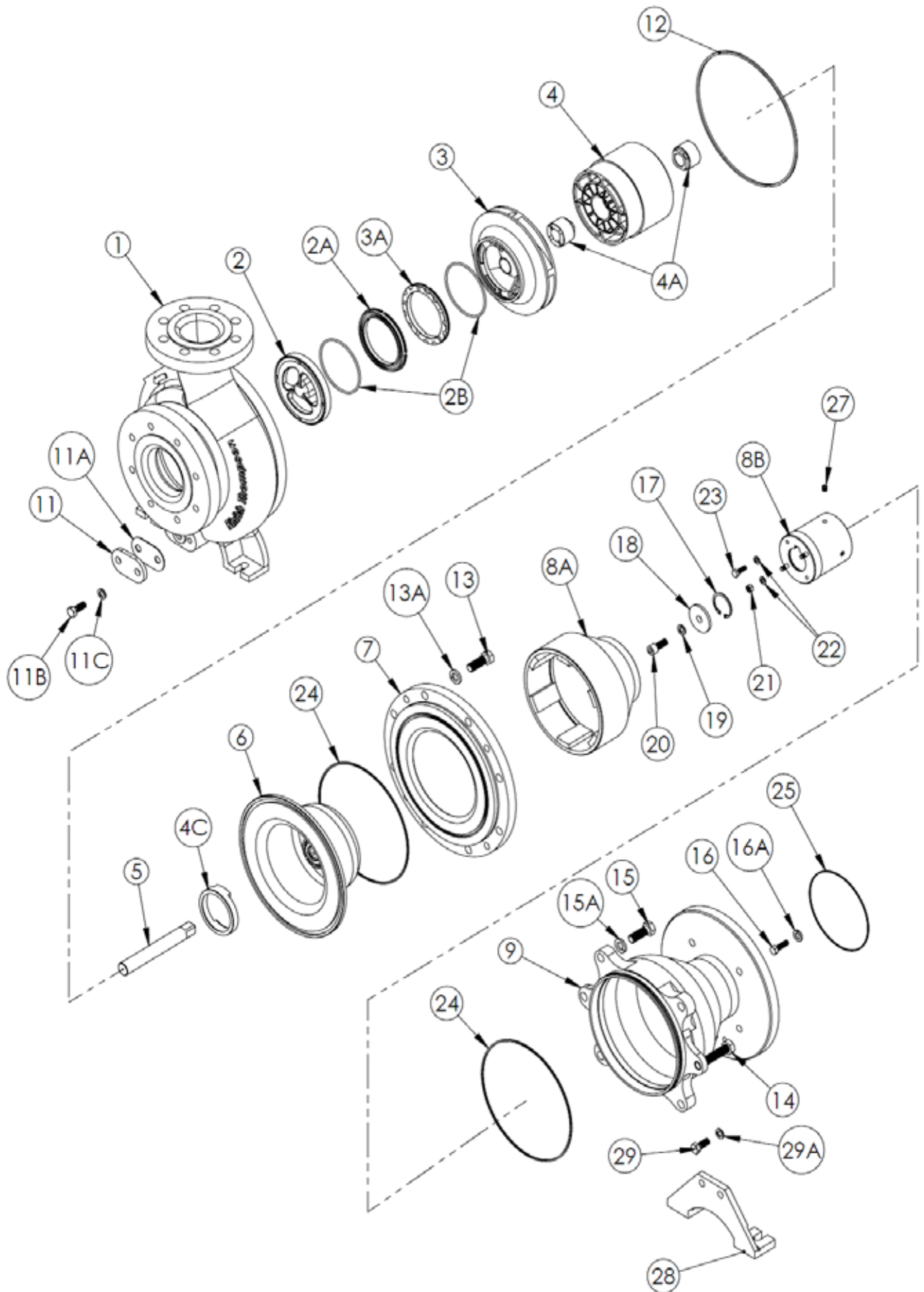

## UCII Spare Parts

Item	Qty	Description	Part Number
1	1	<b>Casing (ETFE-lined, Painted Ductile Iron)</b>	
		UC438- 150# flange	108251-1
		UC438- 300# flange	108251-2
		UC438- ISO PN40 flange	108251-3
		UC436- 150# flange	107782-1
		UC436- 300# flange	107782-2
		UC436- ISO PN40 flange	107782-3
		UC3158- 150# flange	108252-1
		UC3158- 300# flange	108252-2
		UC3158- ISO PN40 flange	108252-3
		UC328 - 150# flange	110153
2	1	<b>Front Shaft Support Only</b>	
		2A sold separately	107666
2A	1	<b>Silicon Carbide Front Thrust Ring Only</b>	
			107736
2B	2	<b>PTFE Encapsulated O-Ring</b>	
		O-Ring	108571
3	1	<b>Impeller Assembly</b>	
		With thrust ring & PTFE Encapsulated O-ring	See charts on pg. 23
3A	1	<b>Impeller Thrust Ring, Silicon Carbide</b>	
			107737
4	1	<b>Impeller Drive Hub Assembly - ETFE</b>	
		"B" Magnet 6-Pole	107688
		"C" Magnet 8-Pole	107688-1
		"D" Magnet 10-Pole	107688-2
		"E" Magnet 12-Pole	107688-3
4A	2	<b>Bushing</b>	
		Silicon carbide	107738
		Carbon	107738-1
		Dri-Coat Silicon Carbide (diamond-like carbon coating)	107738-2
4C	1	<b>Rear Sealing Ring</b>	
		Moly Filled PTFE	107747
5	1	<b>Shaft</b>	
		Silicon carbide	107735
		Silicon carbide with Dri-Coat diamond-like coating	107735-1
6	1	<b>Barrier Assembly</b>	
		Carbon Filled ETFE liner w/ Aramid Reinforced Shell	108104
7	1	<b>Clamp Ring</b>	
		Painted Ductile Iron	108664
8A	1	<b>Outer Drive Magnet Hub-Painted Ductile Iron</b>	
		"B" Magnet 6-Pole	108106-1
		"C" Magnet 8-Pole	108106-2
		"D" Magnet 10-Pole	108106-3
		"E" Magnet 12-Pole	108106-4

Item	Qty	Description	Part Number
8B	1	<b>Shaft Adapter (includes items Retaining Ring &amp; Set Screws for NEMA Frames)</b>	
		NEMA 143-145TC	108665-1
		NEMA 182-184TC	108665-2
		NEMA 213-215TC	108665-3
		NEMA 254-256TC	108665-4
		NEMA 284-286TSC	108665-5
		NEMA 284-286TC	108665-6
		NEMA 324-326TSC, 364-365TSC	108665-7
		NEMA 324-326TC	108665-8
		NEMA 364-365TC	108665-9
		IEC 90 B5	108666-1
		IEC 100/112 B5	108666-2
		IEC 132 B5	108666-3
		IEC 160 B5	108666-4
		IEC 180 B5	108666-5
		IEC 200 B5	108666-6
		9	1
NEMA 143-145TC	107637		
NEMA 182-184TC, 213-215TC, 254-256TC	107637-1		
NEMA 284-286TC	107637-2		
NEMA 324-326TSC & TC, 364-365TSC & TC	107663		
IEC 90 B5	107637-3		
IEC 100/112 B5	107637-4		
IEC 132 B5	107637-5		
IEC 160/180 B5	107663-1		
IEC 200 B5	107663-2		
IEC 225 B5	107663-3		
NEMA 143-145TC- w/ non-sparking ring (ATEX)	108673-1		
NEMA 182-184TC, 213-215TC, 254-256TC- w/ non-sparking ring (ATEX)	108673-2		
NEMA 284-286TC- w/ non-sparking ring (ATEX)	108673-3		
NEMA 324-326TSC & TC, 364-365TSC & TC- w/ non-sparking ring (ATEX)	108673-7		
IEC 90 B5- w/ non-sparking ring (ATEX)	108673-4		
IEC 100/112 B5- w/ non-sparking ring (ATEX)	108673-5		
IEC 132 B5- w/ non-sparking ring (ATEX)	108673-6		
IEC 160/180 B5- w/ non-sparking ring (ATEX)	108673-8		
IEC 200 B5- w/ non-sparking ring (ATEX)	108673-9		
IEC 225 B5- w/ non-sparking ring (ATEX)	108673-10		
11	1	<b>Drain Cap</b>	
		304 SSSL	107743
11A	1	<b>Drain Cap Gasket</b>	
		PTFE	108294
12	1	<b>Barrier O-ring</b>	
		FKM	108569
		EPDM	108570
		Aflas	108661
24	2	<b>Vapor Protection O-Ring- Pump End</b>	
		Buna	108572

Item	Qty	Description	Part Number
25	1	<b>Vapor Protection O-Ring- Motor End</b>	
		Buna	
		Nema 143-145TC	106549
		NEMA 182-184TC, 213-215TC, 254-256TC	108165
		NEMA 284-286TSC & TC	108736
		NEMA 324-326TSC & TC, 364-365TSC & TC	108737
		IEC 90 B5	106572
		IEC 100/112 B5	108974
		IEC 132 B5	108589
		IEC 160 & 180 B5	108594
		IEC 200 B5	108738
IEC 225 B5	108739		
28	1	<b>Foot</b>	
		Painted Ductile Iron	107744

<b>Hardware</b>			
Item	Qty	Description	Part Number
11B	2	<b>Drain Cap Hex Head Bolts</b>	
		M12-1.75 x 30mm, SSTL	106507
11C	2	<b>Drain Cap Lock Washer</b>	
		M12, SSTL	106503
13	8	<b>Casing Hex Head Cap Screw</b>	
		M16-2 X 45mm, SSTL	108675
13A	8	<b>Casing Lock Washers</b>	
		M16, SSTL	107924
14	2	<b>Jack Bolt</b>	
		M16-2.0 x 80 mm, SSTL	107102
15	4	<b>Motor Adapter bolts</b>	
		M16-2 X 45mm, SSTL	108675
15A	4	<b>Motor Adapter Lock Washers</b>	
		M16, SSTL	107924
16	4	<b>Motor Bolts* (Nema Only)</b>	
		NEMA 143-145TC, 3/8-16 x 1-1/2", SSTL	J103207
		NEMA 182-184, 213-215, 254-256, 284-286TSC or TC- 1/2-13 x 1-1/2", SSTL	J101858
16A	4	NEMA 324-326, 364-365TSC or TC- 5/8-11 x 1-1/2", SSTL	J100776
		<b>Motor Lock Washers* (Nema Only)</b>	
		NEMA 143-145TC, 3/8" SSTL	J100115
16A	4	NEMA 182-184, 213-215, 254-256, 284-286TSC or TC- 1/2" SSTL	J101023
		NEMA 324-326, 364-365TSC or TC- 5/8", SSTL	J104026
17	1	<b>Retaining Ring</b>	
		NEMA 143-145TC, DHT-22	105709
		NEMA 182-184TC, DHT-28	105710
		NEMA 213-215TC, DHT-35	106454
		NEMA 254-256TC, DHT-42	106718
		NEMA 284-286TSC, DHT-42	106718
		NEMA 284-286TC, DHO-48	108667
		NEMA 324-326, 364-365TSC, DHO-48	108667
		NEMA 324-326TC, DHO-55	108668
		NEMA 364-365TC, DHO-60	108669
		IEC 90, DHT-24	105712
		IEC 100/112, DHT-28	105710
		IEC 132, DHT-38	106468
		IEC 160, DHT-42	106718
		IEC 180, DHO-48	108667
IEC 200, DHO-55	108668		

Item	Qty	Description	Part Number
19	1	<b>Shaft Adapter Lock Washer (IEC Only)</b>	
		IEC 90- 5/16, SSTL	J102282
		IEC 100/112- M10, SSTL	105757
		IEC 132- M12, SSTL	106503
		IEC 160/180- M16	107924
18	1	<b>Shaft Adapter Washer (IEC Only)</b>	
		IEC 90 FR	108383
		IEC 100 FR	108383-1
		IEC 132 FR	108383-2
		IEC 160 FR	108383-3
		IEC 180 FR	108383-4
		IEC 200 FR	108383-5
20	1	<b>Shaft Adapter Bolt (IEC Only)</b>	
		IEC 90- M8-1.25 x 35 mm, SSTL	J103662
		IEC 100/112- M10-1.5 x 30mm, SSTL	105774
		IEC 132- M12-1.75 x 30mm, SSTL	106507
		IEC 160/180 m16-2 x 35mm, SSTL	108270
21	2	<b>Drive Nut</b>	
		M8 Hex Nut, SSTL	J103930
22	4	<b>Drive Lock Washers</b>	
		5/16" SSTL	J102282
23	2	<b>Drive Bolt</b>	
		M8-1.25 x 25mm, SSTL	J103662
27	2	<b>Shaft Adapter Set Screw</b>	
		3/8-16 x 3/8 Knurled Cup Point, SSTL	110112
29	2	<b>Foot Bolt</b>	
		M12-1.75 x 30mm, SSTL	106507
29A	2	<b>Foot Lock Washer</b>	
		M12, SSTL	106503
30	1	<b>Outer Drive Protection Tube</b>	
		Cardboard tube (for assembly use only)	108927

\*For all IEC B5 motors, hardware to attach the motor (not shown) to the motor adapter (Item 13) is to be supplied by customer due to variations in B5 frame motors.

<b>UC438 Impeller Part Numbers</b>	
<b>Includes SiC Thrust Ring and PTFE Encapsulated O-Ring</b>	
<b>Imp Dia.</b>	<b>Part Number</b>
8.25"	108239-1
8.13"	108239-2
8.00"	108239-3
7.88"	108239-4
7.75"	108239-5
7.63"	108239-6
7.50"	108239-7
7.38"	108239-8
7.25"	108239-9
7.13"	108239-10
7.00"	108239-11
6.88"	108239-12
6.75"	108239-13
6.63"	108239-14
6.50"	108239-15
6.38"	108239-16
6.25"	108239-17
6.13"	108239-18
6.00"	108239-19

<b>UC3158 Impeller Part Numbers</b>	
<b>Includes SiC Thrust Ring and PTFE Encapsulated O-Ring</b>	
<b>Imp Dia.</b>	<b>Part Number</b>
8.25"	108240-1
8.13"	108240-2
8.00"	108240-3
7.88"	108240-4
7.75"	108240-5
7.63"	108240-6
7.50"	108240-7
7.38"	108240-8
7.25"	108240-9
7.13"	108240-10
7.00"	108240-11
6.88"	108240-12
6.75"	108240-13
6.63"	108240-14
6.50"	108240-15
6.38"	108240-16
6.25"	108240-17
6.13"	108240-18
6.00"	108240-19

<b>UC436 Impeller Part Numbers</b>	
<b>Includes SiC Thrust Ring and PTFE Encapsulated O-Ring</b>	
<b>Imp Dia.</b>	<b>Part Number</b>
6.50"	108239-15
6.38"	108239-16
6.25"	108239-17
6.13"	108239-18
6.00"	108239-19
5.81"	108242-1
5.61"	108242-2

<b>UC328 Impeller Part Numbers</b>	
<b>Includes SiC Thrust Ring and PTFE Encapsulated O-Ring</b>	
<b>Imp Dia.</b>	<b>Part Number</b>
8.25"	108240-1
8.13"	108240-2
8.00"	108240-3
7.88"	108240-4
7.75"	108240-5
7.63"	108240-6
7.50"	108240-7
7.38"	108240-8
7.25"	108240-9
7.13"	108240-10
7.00"	108240-11
6.88"	108240-12
6.75"	108240-13
6.63"	108240-14
6.50"	108240-15
6.38"	108240-16
6.25"	108240-17
6.13"	108240-18
6.00"	108240-19



**FINISH THOMPSON INC.**

921 Greengarden Road • Erie, PA 16501-1591 U.S.A.  
Ph 814-455-4478 • Fax 814-455-8518  
Email [fti@finishthompson.com](mailto:fti@finishthompson.com) • [www.finishthompson.com](http://www.finishthompson.com)

Part Number 108725, R3 5/19/15

