

SP Series: Model SPI0

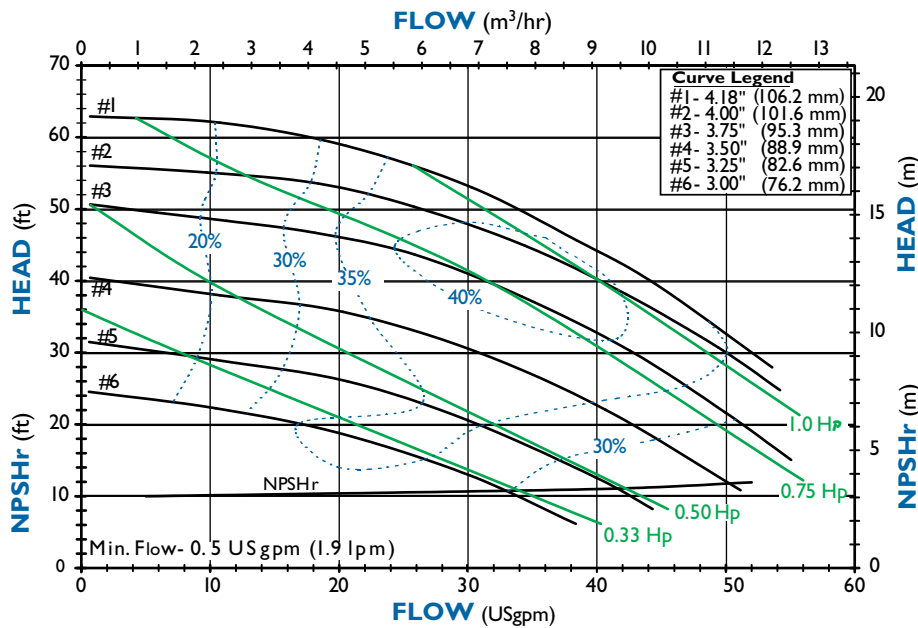

SPI0 PERFORMANCE Flooded Suction 3450 RPM*



SPI0 PERFORMANCE Flooded Suction 2900 RPM*

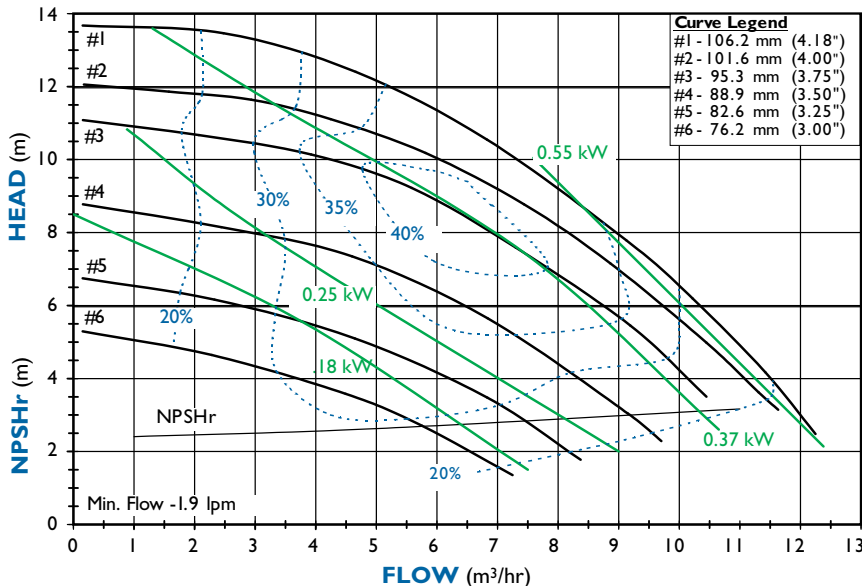

Notes: Performance curves above are based on flooded suction.

*Performance will vary with suction lift conditions. For performance at various suction lifts, see curve book on FTI web site (www.finishthompson.com) or contact factory.

Warning! SP Series not recommended for pumping flammables!

FEATURES & CAPABILITIES

- + Self-priming, magnetic drive
- + Five-year warranty
- + Provides up to 25 ft. (7.6 m) lift or equivalent
- + Primes 15 ft. (4.6 m) in < 2 minutes with maximum diameter impeller
- + Retains fluid for re-priming when shut off without a check valve
- + Extended run dry ability (with carbon bushing)
- + High operating efficiency
- + Polypropylene or PVDF construction
- + Powerful neodymium magnets
- + Close-coupled design
- + Threaded (NPT or BSP), union or flange connections
- + Back pullout design
- + Mounts to NEMA and (B5 & B14) IEC motor frames
- + Easy set measurement free drive
- + ISO 1940 G2.5 balancing
- + CE certified
- + High working pressure up to 80 psi (5.5 bar)
- + Specific gravity over 1.8
- + Polypropylene—180° F (82° C)
- + PVDF—220° F (104° C)

APPLICATIONS

- + Rail cars
- + Tanker trucks
- + Tanks with an opening on top
- + Bulk storage to day or process tank transfer
- + Sumps and reservoirs
- + Below grade storage tanks
- + Over-the-wall applications
- + When run-dry protection is needed
- + and many more!

Description	Polypropylene Models	PVDF Models
1 Housing		
4 Separator plate	Glass-fiber reinforced polypropylene	Carbon-fiber reinforced PVDF
6 Inner volute		
7 Impeller		
3A, 5, 10 O-ring options	FKM, EPDM	
3 Fill and drain plugs*	Polypropylene	PVDF
6A Inner volute thrust ring options	High purity alumina ceramic, silicon carbide	
7A Impeller thrust washer options	Molybdenum disulfide filled PTFE, silicon carbide	
8 Inner drive	Neodymium iron boron magnets encapsulated in unfilled polypropylene	Neodymium iron boron magnets encapsulated in unfilled PVDF
8A Bushing options	Carbon, PTFE, high purity alumina ceramic, silicon carbide	
9 Shaft options	High purity alumina ceramic, Hastelloy® C, silicon carbide	
11 Barrier	Glass-fiber reinforced polypropylene	Carbon-fiber reinforced PVDF
11A Barrier thrust ring	High purity alumina ceramic	
12 Motor adapter	Glass fiber reinforced polypropylene	
13 Outer drive magnets	Nickel-plated neodymium iron boron magnets/steel	
14, 14A, 14B Motor adapter o-rings	Buna N (std.), FKM, EPDM	
15 Clamp ring	Carbon steel	

*Fill plug not shown

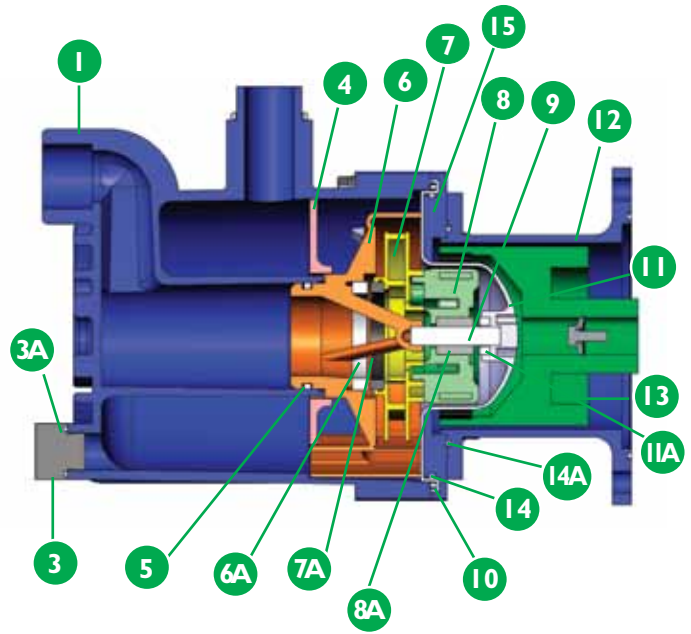

Hastelloy® C is a registered trademark of Haynes International, Inc.

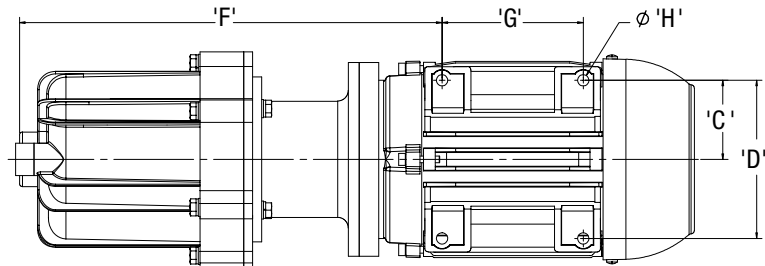
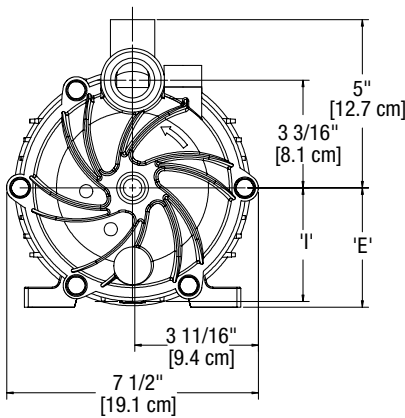
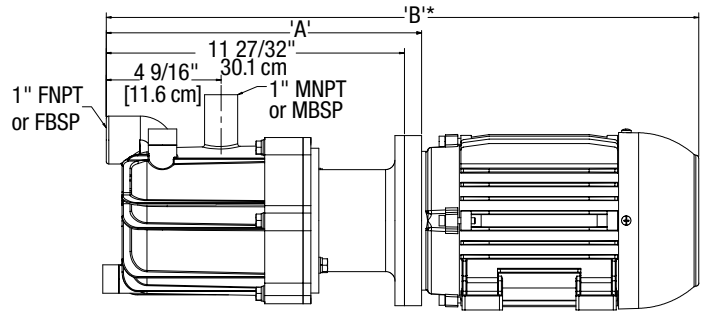

Frame Size	A	B*	C	D	E
NEMA 56C	11-27/32" (30.1 cm)	22-3/32" (56.1 cm)	2-7/16" (6.2 cm)	4-7/8" (12.4 cm)	3-1/2" (8.9 cm)
NEMA 145TC	11-27/32" (30.1 cm)	23-1/16" (58.6 cm)	2-3/4" (7.0 cm)	5-1/2" (14.0 cm)	3-1/2" (8.9 cm)
IEC63 B14/B5	12-3/16" (31.0 cm)	18-31/32" (48.2 cm)	1-31/32" (5.0 cm)	3-15/16" (10.0 cm)	2-15/32" (6.3 cm)
IEC71 B14/B5	12-3/16" (31.0 cm)	20-1/2" (52.0 cm)	2-7/32" (5.6 cm)	4-13/32" (11.2 cm)	2-25/32" (7.1 cm)
IEC80 B14/B5	12-17/32" (31.8 cm)	21-3/4" (55.2 cm)	2-15/32" (6.3 cm)	4-29/32" (12.5 cm)	3-5/32" (8.0 cm)
IEC90 B14/B5	12-17/32" (31.8 cm)	23-17/32" (59.8 cm)	2-3/4" (7.0 cm)	5-1/2" (14.0 cm)	3-17/32" (9.0 cm)

Frame Size	F	G	H	I	Pump Wt. - lbs (kg)	Motor Wt.** - lbs. (kg)
NEMA 56C	14-19/32" (37.1 cm)	3" (7.6 cm)	11/32" (0.9 cm)	3-3/8" (8.6 cm)	13 (5.9)	28 (12.7)
NEMA 145TC	14-7/32" (36.1 cm)	5" (12.7 cm)	11/32" (0.9 cm)	3-3/8" (8.6 cm)	13 (5.9)	32 (14.5)
IEC63 B14/B5	13-5/16" (33.8 cm)	3-5/32" (8.0 cm)	9/32" (0.7 cm)	3-3/8" (8.6 cm)	16.5 (7.5)	17 (7.7)
IEC71 B14/B5	14-1/16" (35.7 cm)	3-17/32" (9.0 cm)	9/32" (0.7 cm)	3-3/8" (8.6 cm)	16.5 (7.5)	22 (10.0)
IEC80 B14/B5	14-7/16" (36.7 cm)	3-15/16" (10.0 cm)	13/32" (1.0 cm)	3-15/16" (10.0 cm)	19 (8.6)	37.5 (17.0)
IEC90 B14/B5	14-23/32" (37.4 cm)	3-15/16" (10.0 cm)	13/32" (1.0 cm)	3-15/16" (10.0 cm)	19 (8.6)	37.5 (17.0)

Dimensions and weights are for reference only.

*Varies with motor manufacturer.

** Depends upon motor manufacturer and style of motor chosen.

