



FINISH THOMPSON INC.

## KC3, 4, & 5 SERIES Sealless Non-Metallic Centrifugal Pumps Installation and Maintenance Instructions

### INSTALLATION

**WARNING: Magnetic field hazard.** This pump contains powerful rare earth magnets. When the pump is disassembled (not connected to a motor) and the magnets are exposed, these magnets produce powerful magnetic fields. Individuals with cardiac pacemakers, implanted defibrillators, other electronic medical devices, metallic prosthetic heart valves, internal wound clips (from surgery), metallic prosthetic devices or sickle cell anemia must not handle or be in the proximity of the magnets contained inside the pump. Consult a health care provider for specific recommendations before working with this pump.

### MOUNTING

Motor should be securely fastened.

### PIPING

1. Support piping near the pump to eliminate any strain on the pump casings.
2. To minimize head loss from friction:
  - (a) Increase pipe size by 1 diameter.
  - (b) Use minimal number of pipe bends.
3. Position pump as close to the liquid source as possible.
4. Maintain a flooded suction (liquid above the pump prior to being primed).
5. Ensure that the piping does not leak and suction is not prone to clogging.
6. If flexible hose is preferred, use a reinforced, chemically compatible hose rated for the proper temperature and pressure. This helps avoid collapse or kinks.
7. Install valves on suction and discharge lines (a minimum of 10 pipe diameters from the pump).
8. For units in a suction lift system, install appropriate piping in the discharge to allow priming of the pump.
9. The suction valve should be completely open to avoid restricting the suction flow.
10. When pumping liquids that may solidify or crystallize, a flush system should be added to the piping. See Figure 1. Install water inlet and outlet valves as shown.

**CAUTION:** To stop the pump if prime is lost, use one of the following: (1) pressure switch on the discharge, (2) vacuum switch on the suction, (3) a power monitor to monitor pump motor power.

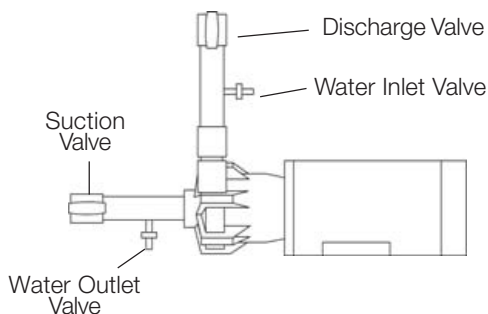

Figure 1

### ELECTRICAL

1. Install the motor according to NEC requirements and local electrical codes. Motor should have an overload protection circuit.
2. Wire the motor for counter clockwise rotation when facing the fan end of the motor.
3. To verify the correct rotation of the motor:
  - a. Install the pump into the system.
  - b. Fully open the suction and the discharge valves.
  - c. Allow fluid to flow into the pump. Do not allow the pump to run dry. (Due to the unique magnetic design of this pump, it can't be run dry without damage to the internal pump components).
  - d. Jog the motor (allow it to run for only one to two seconds) and observe the rotation of the motor fan. Refer to the directional arrow on the pump if needed.

**NOTE:** A pump running backwards will pump but at a greatly reduced flow and pressure.

### OPERATION

#### FLOODED SUCTION SYSTEM

1. Completely open suction and close discharge valve.
2. Start the pump. Adjust the flow rate and pressure by regulating the discharge valve. Do not attempt to adjust the flow with the suction valve.
3. Check liquid flow. If there is no flow, see the Troubleshooting section.

#### SUCTION LIFT SYSTEM

1. Prime the system by filling the priming chamber and/or suction line with liquid.
2. Allow time for trapped air to work its way out.
3. Start the pump. Adjust the flow rate and pressure by regulating the discharge valve. Do not attempt to adjust the flow with the suction valve.
4. Check liquid flow. If there is no flow, see the Troubleshooting section.

#### FLUSH SYSTEMS

**CAUTION:** Some liquids react with water.

1. Completely close suction and discharge valves.
2. Connect water (or flush solution) supply to water inlet valve.
3. Connect drain hose to water valve.
4. Open inlet and outlet valves. Flush system until pump is clean (approximately 5 minutes).

## MAINTENANCE

### DISASSEMBLY

1. Disconnect power. Remove electrical wiring and motor mounting bolts.
2. Close suction and discharge valves. Disconnect piping.
3. Remove nuts, lock washers and flat washers from motor studs.
4. Pull the pump assembly (items 1, 2, 2A, 3, 5, 6) off the motor.
5. Remove the screws (item 6) holding the pump assembly together and separate the impeller housing (item 1) from the barrier assembly (item 3).
6. Remove the drive magnet assembly (item 4), if necessary, to change the motor. Use a 1/8" Allen wrench to loosen the two set screws (item 4A). Remove the drive magnet assembly from the motor shaft.

**⚠ CAUTION:** Keep the drive magnet and impeller assemblies away from metal chips or particles.

### EXAMINATION

1. Check the impeller drive bushing, thrust ring, ceramic thrust ring and ceramic shaft for cracks, chips, scoring or excess wear. See Figure 2. Replace as required.

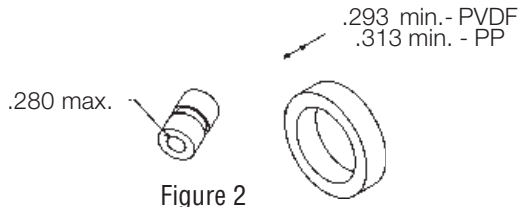

2. Check for loose magnets on the drive magnet assembly or rubbed areas on the impeller or barrier assemblies.
3. Check the o-ring for damage, cracking or swelling. Replace as required.
4. If you did not remove the drive magnet assembly, check the set screws for tightness before reassembly.

### REASSEMBLY

1. Place the impeller assembly (item 2, 2A) over the ceramic shaft in the barrier.
2. Install the o-ring (item 5) on the impeller housing (item 1). Lubricate the o-ring with a compatible lubricant to facilitate o-ring installation.
3. Place the impeller housing (item 1) onto the barrier (item 3) being careful not to dislodge the o-ring.
4. Align the holes in the impeller housing and barrier and install the 8 mounting screws (item 6). Using a screwdriver, hand-tighten screws being careful not to overtighten.
5. If the drive magnet (item 4) was removed, reinstall by sliding drive magnet assembly onto the motor shaft until a distance of 1.69" +/- .015" is measured from the face of the motor to the top of the drive magnet. See Figure 3. Align one set screw (item 4A) with flat on motor shaft and tighten both set screws with 1/8" Allen wrench to 70 in-lbs. (7.9 N-m).

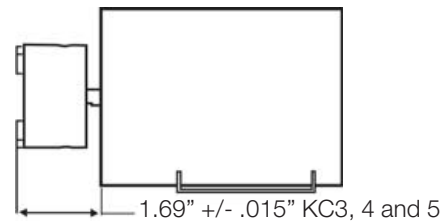

Figure 3

6. Carefully slide the pump assembly over the drive magnet assembly. Orient the discharge to either 12 or 3 o'clock position. Align bolts from the motor with the holes in the barrier. Install flat washer, lock washer and nuts. Securely tighten nuts.
7. Manually rotate pump assembly to ensure that the pump is not binding or rubbing on the drive magnet assembly.

### GENERAL NOTES

1. Do not allow the KC3, 4, or 5 to run dry.
2. Do not pump liquids containing metal fines.
3. Orient the discharge port to either 12 or 3 o'clock position.
4. The setting of the drive magnet dimension is critical. Failure to properly set the proper dimension may result in decoupling or damage to pump components.
5. Make sure the pump is filled with liquid before starting the pump.
6. If magnets decouple, stop the pump immediately. The rare earth magnets used in this pump are more resistant to demagnetization than ceramic, but operating the pump with the magnets decoupled will eventually weaken the magnets.
7. Plastic pumps will expand and contract with temperature so periodically check and hand tighten the screws.
8. An information sticker is attached to the barrier section. The first line is the model number, the second line is the serial number. See Figure 4.



Figure 4

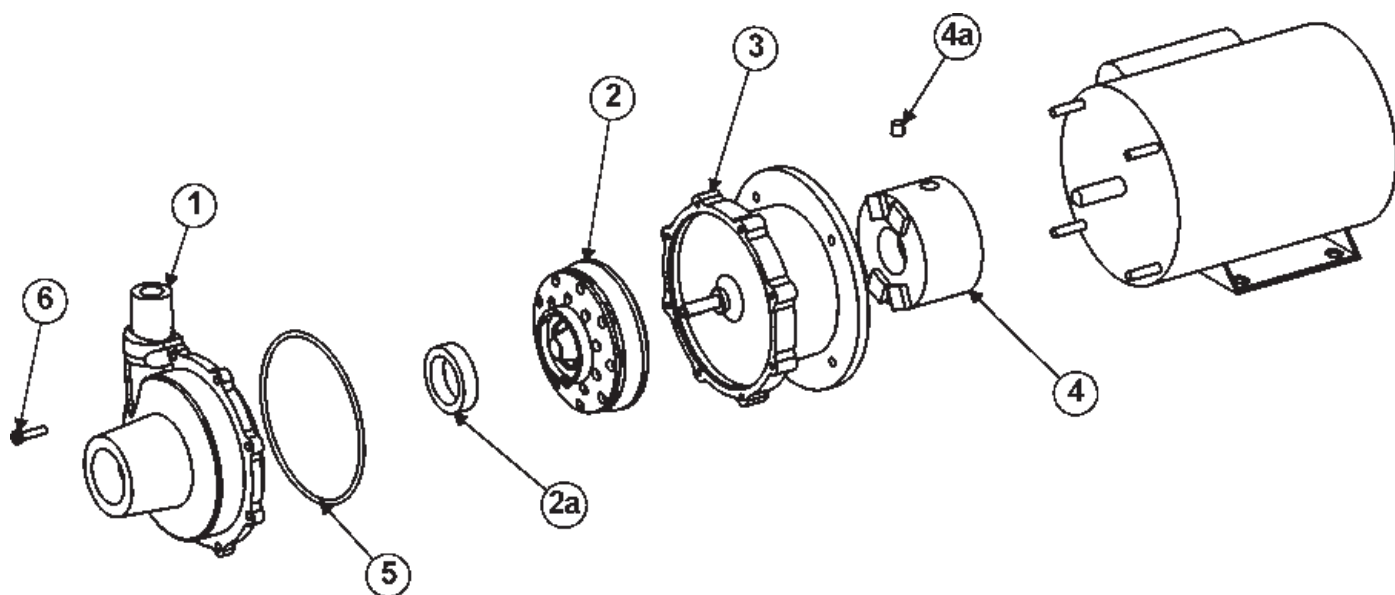

Figure 5

Item	Qty	Description	Pump	Thread	PP Part No.	PVDF Part No.
1	1	Impeller Housing with Thrust Ring	KC 3, 4, 5	NPT	A102865-1	A102865-3
1	1	Impeller Housing with Thrust Ring	KC3, 4, 5	BSP	A102865-2	A102865-4
2	1	Impeller Assembly with Thrust Ring and Carbon Bushing	KC3	N/A	A102861-1	A102861-3
2	1	Impeller Assembly with Thrust Ring and PTFE Bushing	KC3	N/A	A102861-2	A102861-4
2	1	Impeller Assembly with Thrust Ring and Carbon Bushing	KC4	N/A	A102861-5	A102861-7
2	1	Impeller Assembly with Thrust Ring and PTFE Bushing	KC4	N/A	A102861-6	A102861-8
2	1	Impeller Assembly with Thrust Ring and Carbon Bushing	KC5	N/A	A102861-9	A102861-11
2	1	Impeller Assembly with Thrust Ring and PTFE Bushing	KC5	N/A	A102861-10	A102861-12
2A	1	Impeller Thrust Ring	KC3, 4, 5	N/A	M102141	M102141-1
3	1	Barrier Assembly with Spindle and Thrust Washer	KC3, 4, 5	N/A	A102858-1	A102858-2
4	1	Drive Magnet Assembly	KC3	N/A	A102869-1	A102869-1
4	1	Drive Magnet Assembly	KC4, 5	N/A	A102869-2	A102869-2
4A	2	Set Screw	KC3, 4, 5	N/A	J100220	J100220
5	1	Housing O-ring -EPDM	KC3, 4, 5	N/A	J103571	J103571
5	1	Housing O-ring -Viton	KC3, 4, 5	N/A	J103572	J103572
6	8	Housing Screws	KC3, 4, 5	N/A	J101020	J101020

---

## TROUBLESHOOTING

### NO OR INSUFFICIENT DISCHARGE

1. Air leaks in suction piping.
2. Pump not primed.
3. Discharge head higher than anticipated.
4. Closed valve.
5. Viscosity or specific gravity too high (magnets uncoupled).
6. Suction lift too high or insufficient NPSH.
7. Check for clogged suction line.
8. Motor rotation incorrect (counterclockwise as viewed from the motor fan end).

### INSUFFICIENT PRESSURE

1. Air or gas in liquid.
2. Impeller diameter too small.
3. Discharge head higher than anticipated.
4. Motor speed insufficient (too low) or motor rotation incorrect (clockwise as viewed through the suction port).

### LOSS OF PRIME

1. Leaking suction line.
2. Foot valve or suction opening not submerged enough.
3. Foot valve too small or leaking.
4. Air or gas in liquid.
5. Foreign matter in impeller.
6. Leaking valve. Suction lift too high or insufficient NPSH.

### EXCESSIVE POWER CONSUMPTION

1. Head lower than rating. Excessive flow.
2. Specific gravity or viscosity too high.

### VIBRATION/NOISE

1. Loose magnet.
2. Drive magnet rubbing.
3. Pump cavitating from improper suction or feed.
4. Motor or piping not properly secured.
5. Foreign object in impeller.

## WARRANTY

Finish Thompson, Inc (manufacturer) warrants this pump product to be free of defects in materials and workmanship for a period of one year from date of purchase by original purchaser. If a warranted defect, which is determined by manufacturer's inspection, occurs within this period, it will be repaired or replaced at the manufacturer's option, provided (1) the product is submitted with proof of purchase date and (2) transportation charges are prepaid to the manufacturer. Liability under this warranty is expressly limited to repairing or replacing the product or parts thereof and is in lieu of any other warranties, either expressed or implied. This warranty does apply only to normal wear of the product or components. This warranty does not apply to products or parts broken due to, in whole or in

part, accident, overload, abuse, chemical attack, tampering, or alteration. The warranty does not apply to any other equipment used or purchased in combination with this product. The manufacturer accepts no responsibility for product damage or personal injuries sustained when the product is modified in any way. If this warranty does not apply, the purchaser shall bear all cost for labor, material and transportation.

Manufacturer shall not be liable for incidental or consequential damages including, but not limited to process down time, transportation costs, costs associated with replacement or substitution products, labor costs, product installation or removal costs, or loss of profit. In any and all events, manufacturer's liability shall not exceed the purchase price of the product and/or accessories.

## CHEMICAL REACTION DISCLAIMER

The user must exercise primary responsibility in selecting the product's materials of construction, which are compatible with the fluid(s) that come(s) in contact with the product. The user may consult Finish Thompson, Inc. (manufacturer) and a manufacturer's representative/distributor agent to seek a recommendation of the product's material of construction that offers the optimum available chemical compatibility.

However neither manufacturer nor agent shall be liable for product damage or failure, injuries, or any other damage or loss arising out of a reaction, interaction or any chemical effect that occurs between the materials of the product's construction and fluids that come into contact with the product's internals.

## ORDERING SPARE PARTS

Spare parts can be ordered from your local distributor. Always refer to the pump model number to avoid error.

## OTHER FINISH THOMPSON PRODUCTS

**Drum Transfer Pumps** are available in sanitary construction, stainless steel, polypropylene, PVDF and CPVC. Flows to 40 gpm, discharge heads to 300 feet and viscosities to 100,000 cP are available.

**Portable Mixers** for turbine mixing and blending handle viscosities to 1,000 cP with gentle, non-vortexing circulation. Available in 316 stainless steel construction.

**Centrifugal Pumps** in polypropylene, PVDF, 316 stainless steel, and ETFE lined ductile iron come with a wide variety of sealing materials. Flows to 330 gpm, discharge heads to 325 feet, and temperatures to 220°F (104°C) are available.

**Call our Technical Service Hot Line, 1-800-888-3743, if you have any questions regarding product operation or repair.**



### FINISH THOMPSON INC.

921 Greengarden Road • Erie, PA 16501-1591 U.S.A.  
Ph 814-455-4478 • Fax 814-455-8518  
Email [fti@finishthompson.com](mailto:fti@finishthompson.com) • [www.finishthompson.com](http://www.finishthompson.com)

FT99-759I, 5-16-07  
Service 800-888-3743  
P/N J103803, Rev. 8

